

Framework for Scheduling, Controlling, and Delivery  
Planning for Scattered Repetitive Infrastructure  
Rehabilitation Projects

by

Ehab Kamarah

A thesis  
presented to the University of Waterloo  
in fulfillment of the  
thesis requirement for the degree of  
Doctor of Philosophy  
in  
Civil Engineering

Waterloo, Ontario, Canada, 2018

© Ehab Kamarah 2018

## Examining Committee Membership

The following served on the Examining Committee for this thesis. The decision of the Examining Committee is by majority vote.

External Examiner

NAME: Khaled El-Rayes

Title: Professor, Civil and Environmental Engineering

University of Illinois

Supervisor(s)

NAME: Tarek Hegazy

Title: Professor, Civil and Environmental Engineering

University of Waterloo

Internal Member

NAME: Carl Haas

Title: Professor, Civil and Environmental Engineering

University of Waterloo

Internal Member

NAME: Scott Walbridge

Title: Associate Professor, Civil and Environmental Engineering

University of Waterloo

Internal-external Member

NAME: Ramadan El-Shatshat

Title: Professor, Electrical and Computer Engineering

University of Waterloo

## **AUTHOR'S DECLARATION**

I hereby declare that I am the sole author of this thesis. This is a true copy of the thesis, including any required final revisions, as accepted by my examiners.

I understand that my thesis may be made electronically available to the public.

## **Abstract**

Public-Sector organizations such as School Boards and Universities are faced with significant challenges to keep their aging facilities operational and reducing the large backlog in infrastructure renewal needs. The cost to bring school and university facilities to acceptable and functional levels in Ontario is estimated to be as high as \$15-billion and \$2.5-billion, respectively. To address this challenge, Ontario government is investing hundreds of millions of dollars in infrastructure renewal every year. While significant literature efforts focused on determining efficient rehabilitation programs, little efforts addressed the delivery phase of such projects. Existing project management systems exhibit serious drawbacks when applied to infrastructure renewal projects that are mainly scattered and repetitive in nature. Planning such projects involves many challenges related to: the multi-location nature of the work (e.g., multiple schools); the need to synchronize multiple crews among multiple sites; the need to consider site productivity influences and work variations; the lack of timely progress tracking and corrective-action planning; and the ineffectiveness of current project delivery methods to handle this type of projects. Overall, existing systems lack the ability to provide near-optimum scheduling and delivery method to facilitate the execution of scattered repetitive projects.

This research introduces an efficient framework for enhancing the planning, scheduling, control, and delivery arrangement of scattered repetitive projects. The framework combines the benefits of Line Of Balance (LOB), the Critical Path Segments (CPS), and optimization techniques to develop a schedule optimization model that takes into account various practical options and constraints, including: optional construction methods, variation of work quantities among sites, possible crew assignment strategies, practical productivity factors, activity-specific site execution order, in addition to deadline, resource limits, and crew mobilization constraints. First, a field study was carried out at two large organizations in Ontario, Canada, that manage a large number of facilities, to identify the practical challenges, work constraints, and the requirements for an efficient management system. Accordingly, the proposed framework was designed to address these needs.

To support decisions during the construction phase, the proposed framework introduces an integrated CPS-LOB scheduling methodology that computes the number of crews to use, the method of construction to utilize, and the order of site execution, given any set of project constraints. For practicality, the scheduling model captures all mid-activity as-built events that enable optimum corrective action planning. This scheduling model is then applied within a Genetic Algorithms optimization procedure that tries millions of combinations of decisions until an optimum schedule is obtained, which meets all constraints at minimum cost. Moreover, the proposed scheduling and control model uses a new legible representation of scattered repetitive schedules to enable better communication of the schedule information among all project parties. To enable the use of the proposed framework in practice, this research introduced an innovative project delivery method called “Modified Construction Manager at Risk (MCMR)” to provide a suitable administrative and contractual environment that suit scattered repetitive projects. As opposed to all existing delivery practices, MCMR allows owner organizations to benefit from repetition and offer real opportunity to achieve significant cost savings. To demonstrate the capabilities and features of the proposed framework, a computer prototype system is developed, and its effectiveness validated using a real-life project. The results of the optimization experiments proved the suitability of the model to handle scattered repetitive projects. The proposed framework offers a powerful decision support features for contractors to make cost-effective decisions, while the proposed MCMR guidelines provide owners with the necessary contractual setup to make this happen. Overall, this framework has the potential to revolutionize the multi-billion-dollar business of infrastructure renewal and provide cost effective decisions that save tax payers’ money on the long run.

## **Acknowledgements**

First and foremost, I thank ALLAH (SW) our Lord, the most Gracious and the most Merciful, for giving me the strength, the ability, and the knowledge to complete this work.

During my studies, many people contributed in a variety of ways to this research. I would like first to express my sincere appreciation and deepest gratitude to my supervisor, Dr. Tarek Hegazy, for his perceptive guidance, extensive assistance, critical insights, inspiration and encouragement, and enriching my research skills over the last several years, without which I would not have been able to complete this work. His valuable advice and commitment far exceeded the call of duty. I am deeply impressed with his wealth of knowledge, excellence in teaching, and dedication to academic research. It has been a great honor to work with him and to learn from his experience.

I would like to extend my sincere appreciation and gratitude to my committee members Prof. Khaled El-Rayes, Prof. Ramadan El-Shatshat, Prof. Carl Haas, and Prof. Scott Walbridge for their insightful comments and their dedicated efforts to this study.

Additional thanks to the facility management teams at many owner organizations for their cooperation during the course of this research. Special thanks to facility management teams at Toronto District School Board and McMaster University for their invaluable input.

I would also like to thank my colleagues in the construction research group for their priceless friendship and support over the last several years. I am as ever, especially indebted to my family, whose love, prayers, and support made this work possible.

## Dedication

*I dedicate this thesis to*

My Parents, my Brothers and Sisters, my Wife, and  
my beloved Layla and Adam.

## Table of Contents

AUTHOR'S DECLARATION.....	iii
Abstract.....	iv
Acknowledgements.....	vi
Dedication.....	vii
Table of Contents.....	viii
List of Figures.....	xi
List of Tables.....	xiv
Chapter 1 Introduction.....	1
1.1 General.....	1
1.2 Research Motivation.....	3
1.2.1 Need for Efficient Scheduling for Scattered Repetitive Projects.....	3
1.2.2 Need for Efficient Project Control for Scattered Repetitive Projects.....	4
1.2.3 Availability of Powerful Optimization Tools.....	4
1.2.4 Need for Suitable Project Delivery Method for Scattered Repetitive Projects.....	5
1.3 Research Objective and Scope.....	6
1.4 Research Methodology.....	7
1.5 Thesis Organization.....	9
Chapter 2 Literature Review.....	11
2.1 Introduction.....	11
2.2 Repetitive Projects.....	11
2.2.1 Bar Chart Method.....	12
2.2.2 Critical Path Method (CPM).....	12
2.2.3 Scheduling Techniques for Repetitive Projects.....	16
2.2.4 Line of Balance (LOB).....	16
2.2.5 Combined Analytical and Graphical Scheduling Methods.....	18
2.3 Project Tracking and Control Methods.....	23
2.4 Optimization Models.....	29
2.4.1 Mathematical Techniques.....	30
2.4.2 Artificial Intelligence Techniques: Genetic Algorithms (GA).....	31
2.5 Project Delivery Methods (PDM).....	34
2.5.1 Design – Bid – Build (DBB) Delivery System.....	35



2.5.2 Design – Build (DB) Delivery System.....	37
2.5.3 Construction Management (CM) Delivery System.....	39
2.5.4 Research Efforts on Project Delivery Methods.....	42
2.6 Summary and Research Gap .....	44
Chapter 3 Field Study on Infrastructure Renewal Scattered Repetitive Projects .....	46
3.1 Introduction .....	46
3.2 Infrastructure Renewal Backlog at Public-Sector Organizations .....	46
3.3 Field Study .....	49
3.3.1 The University.....	50
3.3.2 The School Board.....	52
3.4 Practical Challenges in Delivering Scattered Repetitive Projects .....	54
3.4.1 Service Interruption to Occupied Facilities.....	55
3.4.2 Unforeseen Conditions .....	55
3.4.3 Project Progress Tracking .....	57
3.4.4 Project Delivery Methods.....	60
3.5 Existing Management Systems.....	61
3.6 Discussion and Summary .....	62
Chapter 4 Framework for Scattered Repetitive Scheduling and Control .....	64
4.1 Introduction .....	64
4.2 Components of the Proposed Framework .....	64
4.3 Basic Formulation: Integrated CPM/LOB Scheduling.....	65
4.3.1 Activities’ Durations and Costs.....	66
4.3.2 CPM Calculation for Single Site.....	68
4.3.3 Production Rates and Number of Crews to Meet Deadline .....	68
4.4 Practical Scheduling Constraints for Scattered Repetitive Projects .....	72
4.4.1 Designed Work Interruption.....	72
4.4.2 Variation of Work Quantities at Different Scattered Sites.....	74
4.4.3 Optional and Correlated Construction Methods.....	75
4.4.4 Representation of Variable Execution Orders.....	77
4.4.5 Moving Time and Cost.....	80
4.4.6 Crew Limits and Assignments Strategies.....	82

4.5 Project Control for Scattered Repetitive Projects .....	85
4.5.1 Representation of Daily Progress Events .....	85
4.5.2 Updating the Schedule Based on Progress Events .....	88
4.5.3 Corrective-Action Decisions .....	90
4.6 Cost and Schedule Optimization Model .....	97
4.7 Discussion and Summary .....	101
Chapter 5 Model Implementation: A Case Study .....	102
5.1 Introduction.....	102
5.2 Case Study .....	102
5.3 Framework Implementation: A Computer Prototype .....	106
5.3.1 Project Calendar and Parameter .....	107
5.3.2 Activities of a Single Site.....	107
5.3.3 Logical Relationships Between Activities .....	108
5.3.4 Specifying the Scattered Sites .....	108
5.3.5 Practical Constraints.....	109
5.3.6 Scheduling and Cost Calculations.....	111
5.3.7 Framework Verification .....	118
5.4 Project Control.....	122
5.5 Discussion and Summary.....	127
Chapter 6 Project Delivery Method (PDM) for Scattered Repetitive Projects .....	128
6.1 Introduction.....	128
6.2 Typical DBB and CMR Project Delivery Methods .....	128
6.3 Challenges with Delivering Scattered Repetitive Projects.....	135
6.4 Modified Construction Manager at Risk (MCMR).....	141
6.5 MCMR Advantages and Evidence of Applicability .....	147
6.6 Summary and Discussion.....	156
Chapter 7 Conclusion and Future Research.....	158
7.1 Introduction.....	158
7.2 Research Contribution .....	159
7.3 Future Research .....	162
References.....	165

## List of Figures

Figure 2.1: CPM Arrow Diagram Method (ADM) .....	13
Figure 2.2 CPM Precedence Diagram Method (PDM) .....	13
Figure 2.3: Network Diagram for Three Unit Project (Based on Suhail and Neal 1994) .....	15
Figure 2.4 LOB Schedule Representation of Three Activities along Five Units .....	17
Figure 2.5: LSM Representation of Three Activities along Five Units.....	18
Figure 2.6 Earned Value Method Representation and Analysis (Based on Chou et al. 2010).....	25
Figure 2.7: Crossover Operator to Generate Offspring Chromosomes (Elbeltagi et al., 2005) .....	32
Figure 2.8: Design-Bid-Build (DBB) Contractual Arrangements.....	36
Figure 2.9 Design-Build (DB) Contractual Arrangement .....	38
Figure 2.10:Construction Manager at Risk (CMR) Contractual Arrangements.....	40
Figure 3.1 Infrastructure Renewal Backlog at Ontario School Boards .....	47
Figure 3.2 Execution Planning for Scattered Repetitive Projects.....	49
Figure 3.3: Infrastructure Renewal Backlog at the University (CBC February 6, 2013).....	50
Figure 3.4:The School Board Map (Ahluwalia, 2008).....	52
Figure 3.5 : Infrastructure Renewal Backlog (Toronto Star August 22, 2016) .....	53
Figure 3.6: Practical Challenges for Infrastructure Renewal Projects.....	54
Figure 4.1: Components of the Proposed Scheduling and Control Framework.....	65
Figure 4.2: CPM Calculations for Single Site .....	68
Figure 4.3:Various Schedule Features for 9 Repetitive Activities .....	69
Figure 4.4: Desired Progress Rate (R).....	70
Figure 4.5 Designed Work Interruption .....	73
Figure 4.6: Variation of Work Quantities along Different Sites .....	74
Figure 4.7: Traditional LOB Representation for Scattered Repetitive Projects .....	78
Figure 4.8: Modified Vertical Axis for Scattered Repetitive Projects.....	78
Figure 4.9: Changing the Work Sequence of Activities A and B Creates a Complex Schedule.....	79
Figure 4.10:Proposed Schedule Representation with Variable Site Index .....	80
Figure 4.11: Moving Time Impact Using One Crew and Different Execution Orders .....	81
Figure 4.12: Moving Time Impact Using Multiple Crews and Different Execution Orders.....	82
Figure 4.13: Improved Crews Assignment Strategy .....	83
Figure 4.14: Crew assignment (First-Come-First-Served) Strategy Calculation .....	84

Figure 4.15 Critical Path Segments (CPS) As-Built Representation .....	86
Figure 4.16: Updated Activity Duration Calculations .....	88
Figure 4.17 Different Types of Activities During Construction .....	91
Figure 4.18: Effects of Various Corrective-Action Decisions .....	92
Figure 4.19 Impact of Corrective Actions at The Activity Level on The Project Schedule .....	95
Figure 4.20: Corrective Actions at the Project Level.....	96
Figure 4.21: Construction Method and Number of Crews Variables .....	97
Figure 4.22: Work Interruption Variable Representation .....	98
Figure 4.23: Site Order Variable Representation.....	98
Figure 5.1: Case Study Activities Network .....	103
Figure 5.2: Project Calendar and Parameters.....	107
Figure 5.3: Three Alternative Construction Methods for each Activity .....	107
Figure 5.4: Locations of Scattered Sites and Productivity Factors .....	108
Figure 5.5: Mechanical Roughing Activity Quantity (% of typical estimate) at Site 4 .....	109
Figure 5.6: Activity Estimates at Non-Typical Sites .....	110
Figure 5.7: Correlated Construction Methods.....	111
Figure 5.8: Initial Schedule without Productivity Factors or Moving Time/Cost .....	112
Figure 5.9: Impact of Productivity Factors on the Project Cost and Duration.....	112
Figure 5.10: Impact of Moving Cost and Time on the Project Cost and Duration .....	113
Figure 5.11: Optimization Options .....	114
Figure 5.12: Optimized Baseline Schedule that Meets Deadline.....	115
Figure 5.13: LOB Diagram Representation with different Paths.....	116
Figure 5.14: LOB Diagram Representation for Individual Activities and Crews.....	117
Figure 5.15: Duration and Cost Calculations for Typical Activity .....	118
Figure 5.16: Duration and Cost Calculations for Non-Typical Activity.....	119
Figure 5.17: First Come First Serve Crews Assignment Strategy .....	120
Figure 5.18: Correlated Construction Methods: Metal Stud & Boarding and Taping Activities .....	120
Figure 5.19: Impact of Changing Activity Site Order on Cost and Duration .....	121
Figure 5.20: First Scenario: The Actual Progress Follows the Baseline Plan.....	122
Figure 5.21: Second Scenario: The Project is Behind Schedule.....	123
Figure 5.22: Implemented Corrective Actions to Recover Schedule Delays.....	124
Figure 6.1: Roles and Responsibilities for Project Parties under CMR Structure .....	132

Figure 6.2: Disadvantages of Current PDM for Infrastructure Scattered Repetitive Projects.....	137
Figure 6.3: Learning Curve Effect.....	138
Figure 6.4: Causes of Unforeseen Conditions .....	140
Figure 6.5: Modified Construction Manager at Risk (MCMR) Structure .....	142
Figure 6.6: Proved and Perceived Advantages of MCMR .....	148

## List of Tables

Table 2-1: Research Efforts for Analysis of Project Performance Metrics (Adapted from Sullivan et al. 2017) .....	1
Table 3-1: Infrastructure Renewal Backlog at Ontario Universities (COU Report 2014).....	48
Table 3-2 VFA Condition Assessment Recommendation (COU Report, 2014) .....	51
Table 3-3: Infrastructure Renewal Projects in 2015/2016 and Renewal Backlog in 2016 .....	54
Table 4-1: Seasonal Productivity Factor (Hegazy and Kamarah 2008).....	67
Table 4-2: Variation of Work Quantities along Scattered Sites.....	75
Table 4-3: Constrained Construction Methods .....	76
Table 4-4: Moving Time and Distance .....	81
Table 5-1: Case Study Activities Details .....	103
Table 5-2: Typical and Non-Typical Sites.....	105
Table 5-3: Conditional Construction Methods.....	105
Table 6-1: Comparison between DBB and CMR .....	131
Table 6-2: Comparison between CMR and MCMR .....	147
Table 6-3: Projects Completed at the School Board in 2015 .....	150
Table 6-4:MCMR Perceived Benefits over DBB: Case Study .....	151

# Chapter 1

## Introduction

### 1.1 General

Municipalities, school boards, hospitals, and other public-sector organizations around the country are faced with significant challenges to keep their services efficiently operational because of the existing billions of dollars in infrastructure renewal backlog. The cost to bring these facilities to acceptable and functional levels in Ontario schools and universities alone are estimated to be as high as \$15-billion and \$2.5-billion, respectively (Ontario Ministry of Education-Facility Condition Report-2016; Council of Ontario Universities Report-2014). To address this challenge, the Ontario government is investing billions of dollars in infrastructure renewal projects every year. A key reason for the exponential backlog increase is the limitations of current project management systems, and the ineffectiveness of current delivery systems for infrastructure renewal projects, which are mainly scattered and repetitive in nature.

The success of construction projects greatly depends on the effectiveness of scheduling, monitoring, and control processes, in addition to the use of a suitable project delivery method. Because most of the current projects involve new technologies, multiple stakeholders, fierce bidding competition, and strict requirements, both the project scheduling and control processes have become more complicated and subject to mistakes. Moreover, selecting the proper project delivery method is critical to the project success as it clearly defines contractual roles and responsibilities, inter-relationships among parties, and the needed processes to manage the project schedule, budget, scope, and quality. Poor scheduling, tracking, control, and the use of inefficient project delivery methods can result in project delays, cost overruns, in additions to costly claims and disputes among parties (Arditi et al., 2002; Mattila and Park, 2003; Moselhi et al., 2004; Oyentunji and Anderson, 2006; Mafakheri et al., 2007; Son and Kim, 2010; El-Asmar et al., 2013; Olawale and Sun, 2013; Carpenter and Bausman, 2016; Liu et al., 2016).

The evidence of the extent of the problems is apparent in the low performance of the construction industry as compared to other industries. Cost overruns and construction delays are becoming standard features of construction projects (Siemiatycki, 2015). For example, 63% of projects in the UK experienced delays, and 58% experienced cost overrun in 2017 (Willington, 2017). Between 31% and 55% of highway projects experienced an average of 44%-time delay in excess of their original duration (Anastasopoulos et al., 2012). More than 40% of construction projects in India suffered from delays that range from 1 to 252 months (Lyer and Jha, 2006). Assaf and AlHejji (2006) reported that 70% of surveyed construction projects experienced schedule delay in Saudi Arabia.

The need for structured and efficient scheduling and control techniques, and suitable project delivery methods, is more apparent for projects with repetitive nature such as highways and pipelines (horizontal), high-rise buildings (vertical), and multi-site infrastructure rehabilitation/renewal (scattered). The latter type of repetitive projects has been at the center of attention for municipalities and large facilities owners as it involves many scattered infrastructure rehabilitation projects such as multiple bridges, multiple road sections, multiple schools, etc. These types of projects are large in size and involve many crews (labor and equipment) that move from one unit to the next, ideally in a synchronized schedule (similar to assembly lines in manufacturing) to avoid delays in project completion. In manufacturing, however, the product moves between stationary labor and equipment, while in repetitive projects, the crews (labor and equipment) are mobile and move between repetitive units (Hassanein and Moselhi, 2004; Yang and Ioannou, 2004).

Currently, the majority of construction companies utilize simple techniques for time and cost control. Existing techniques, however, exhibit serious drawbacks when applied to scattered repetitive projects. Most notably, the inability to consider the scattered multi-location nature of the sites, the inability to incorporate daily site events (by various parties in the schedule), and the inability to optimize corrective actions. In addition, the traditional project delivery methods such as Design-Bid-Build (DBB) have demonstrated serious limitations, particularly when used to deliver infrastructure rehabilitation of scattered projects.



## **1.2 Research Motivation**

This research introduces a framework for schedule optimization and efficient project control to support the execution of scattered repetitive projects. In addition, this research attempts to propose a project delivery method that best suits the scattered repetitive nature of infrastructure rehabilitation (renewal) projects. This research has been motivated by the following:

### **1.2.1 Need for Efficient Scheduling for Scattered Repetitive Projects**

Developing a scheduling model for scattered repetitive projects is a complicated task and a significant challenge. This is due to the geographical separation between sites, the large number of crews that need to be synchronized without interruption, the variation of work quantity among repetitive sites, and the large number of activities and construction methods. Traditional Critical Path Methods (CPM) for construction scheduling have been reported as inadequate for scheduling repetitive projects (Arditi et al., 2002; El-Rayes et al., 2002; Hassanein and Moselhi, 2004; Dolabi et al., 2014).

Despite the advantages of CPM based scheduling techniques, their formulations are not capable of meeting a given deadline, do not maintain work continuity, and do not synchronize successive crews to eliminate crews' idle time, which are essential requirements in scheduling and monitoring of repetitive projects. In the literature, a handful of repetitive scheduling techniques have been introduced by various researchers in the past five decades, most notably the Line of Balance (LOB) (AlSaraj, 1990; Suhail and Neal, 1994; El-Rayes and Moselhi, 1998), Linear Scheduling Model (LSM) (Chrzanowski and Johnston, 1986; Harmlink and Rowings, 1998; Tokdemir, 2006; Tang et al., 2014), and Vertical Planning Method (VPM) (Thabet and Beliveau, 1997; Arditi et al., 2002; Hegazy and Kamarah, 2008). These models, however, do not adequately address the particular challenges of infrastructure rehabilitation scattered repetitive projects, which has recently become increasingly in demand by many municipalities and large public-sector organizations.

### **1.2.2 Need for Efficient Project Control for Scattered Repetitive Projects**

Changes that result in deviations from the original project plans during construction are inevitable. As a result, construction schedules need to be updated frequently in response to these changes and to ensure projects' objectives are achieved. Most of the existing techniques for repetitive projects focus on scheduling projects during the planning phase (before a project starts), as opposed to scheduling update and corrective actions during the project execution (construction) phase. The project control features of existing project management tools and techniques are not adequately developed. This problem is much exacerbated for repetitive projects due to the large amount of data that need to be tracked and reflected on the schedule (Hwang and Liu, 2005; Elbeltagy and Dawood, 2011; Bakri et al., 2014; Olawale and Sun, 2014; Tang et al., 2014).

Schedule updating is a significant challenge as existing tools are unable to record the evolution of various as-built events caused by all parties and to incorporate these events directly on the schedule. Moreover, determining the appropriate corrective actions to alleviate any deviation from the original project plans is a complicated task (Cho et al., 2010; Son and Kim, 2010; Hegazy and Abdel-Monem, 2012; Hegazy et al., 2014). In addition, most existing software tools make an inaccurate assumption that the remaining work of on-going tasks will follow the planned progress rates, even if the completed work is slower than planned. This assumption miscalculates project deviation and could result in inaccurate corrective actions. There is a need, therefore, for an efficient control model that is capable of documenting progress events on the schedule and providing decision support for identifying the optimum course of corrective actions at any time during construction.

### **1.2.3 Availability of Powerful Optimization Tools**

Construction management problems, particularly scattered repetitive projects, are complex and involve many decisions related not only to the construction methods to use and the resources to employ, but also the best sequence of work among the scattered units. This requires an efficient mathematical representation of all the decision variables and constraints in the form of an optimization problem and using proper optimization tool to search for a solution. To

handle practical-size problems, development in Artificial Intelligence (AI) technology has produced a new breed of tools that are beneficial for construction management applications. In recent years, Evolutionary Algorithms (EAs) tools, such as Genetic Algorithms (GA), have become increasingly popular and have proven to be capable of arriving at near-optimal solutions for reasonable-size problems. GAs have been applied successfully to several areas in engineering and construction management. Applications include time-cost tradeoff, resource leveling, and resource allocation for repetitive and non-repetitive projects (Hegazy, 1999; Leu and Yang, 1999; Cheng and Ko 2003; Zheng et al., 2004; Senouci and Eldin, 2004; Hegazy and Kamarah, 2008; Long and Ohsato, 2009; Fan et al., 2012; Damci et al., 2013; Huang et al., 2016). However, the existing GA based scheduling models do not address the unique characteristic of scattered repetitive projects, particularly the crew moving-time/cost, and the proper execution order among the scattered sites. In addition, the tracking and control features of these models are lacking and incapable of incorporating the daily progress events of all parties, to facilitate performance analysis and corrective actions.

#### **1.2.4 Need for Suitable Project Delivery Method for Scattered Repetitive Projects**

A Project Delivery Method (PDM) is the process of assigning roles and responsibilities to parties involved in designing, procuring, and constructing a project. It defines the project contractual setup, inter-relationships among parties, and the needed processes for schedule, budget, quality and scope management to complete a project from inception to completion. The suitability of the project delivery method is critical to the project success and significantly impacts the efficiency of the project execution (Mahdi and Alreshaid, 2005; Oyentunji and Anderson, 2006; El Asmar et al., 2013; Carpenter and Bausman, 2016).

In practice, various project delivery methods have evolved to fit various projects and owner needs. The Design-Bid-Build (DBB) is considered the “traditional” mean of delivering construction projects and the most frequently used project delivery method, particularly for public-sector, for most of the twentieth century. Despite its extensive use and long history, the use of DBB has demonstrated significant drawbacks and most projects using this delivery

method are experiencing delays and cost overruns. The DBB hinders the project team ability to fast-track projects, exposes the owner to significant number of change orders, and creates adversarial atmosphere among the project parties (Alkhalil, 2002; Mafakheri et al., 2007; Rajos and Kell, 2008; Shrestha et al., 2012; Gofar et al., 2014; Tran and Molenaar, 2015; Sullivan et al., 2017).

While many delivery methods exist in practice and can alleviate some of the DBB drawbacks; however, they do not adequately consider the unique challenges encountered by public-sector organizations in implementing scattered infrastructure renewal programs. Therefore, there is an emerging need for a modified project delivery method that recognizes these challenges and provides public-sector organizations with effective management tools to deliver infrastructure rehabilitation projects in a timely and cost-efficient manner.

### **1.3 Research Objective and Scope**

The main objective of this research is to develop an integrated scheduling, cost optimization, and control framework along with a suitable project delivery method for the construction of scattered repetitive projects. The proposed framework enables project teams to optimize execution plans considering practical constraints, deviations from baseline plans, corrective action needs, and the project delivery arrangement. The following are the detailed objectives of this research:

1. Investigate current practices for scheduling and control of scattered repetitive projects through a field study, to identify the practical challenges and constraints associated with scheduling and control of such projects;
2. Develop an efficient scheduling framework with a mathematical formulation that is suitable for scattered repetitive projects and accounts for the identified challenges and constraints. The framework incorporates project control features to represent daily progress events of all project participants, and reflects their impact on the schedule;

3. Develop a genetic algorithm-based optimization model and apply it to the scheduling model of scattered projects to determine the optimum baseline plan before construction and the optimum corrective action during construction;
4. Develop a computer prototype of the proposed framework and experiment with a real case study project to refine the development and demonstrate its effectiveness; and
5. Examine current project delivery methods used in several real cases of scattered repetitive projects, discuss their advantages and disadvantages, and suggest improvements to provide public-sector organizations with a more effective and flexible project delivery method to implement their infrastructure renewal programs.

The proposed framework offers powerful decision support features for contractors to make cost-effective decisions, while the proposed MCMR guidelines provide owners with the necessary administrative and contractual setup to make this happen. Overall, this framework has the potential to revolutionize the multi-billion-dollar business of infrastructure renewal and provide cost-effective decisions that save taxpayers' money on the long run.

#### **1.4 Research Methodology**

The methodology for achieving the above objectives is described as follows:

1. **Comprehensive literature review:** An extensive literature review has been conducted to assess the theory and current developments that relate to scheduling, control and cost optimization for scattered repetitive projects. The review focused on various tools utilized in the development of scheduling and control systems for repetitive construction projects, and the current and emerging optimization techniques to develop these tools. In addition, the existing project delivery methods utilized to deliver these projects were described, and the related research efforts to determine their advantages and disadvantages are discussed.
2. **Current Industry Practices:** Investigate the current practices adopted by large public organizations for scheduling, monitoring and control of scattered repetitive projects to

identify the factors that impact the performance of such projects. Several practical considerations are identified and considered in the development of the proposed scheduling and control of scattered repetitive projects;

3. **Scheduling and Control Framework:** Once the practical challenges and constraints are identified, develop scheduling and control framework with a mathematical formulation for scattered repetitive projects that considers identified practical considerations and the limitations of current systems. The framework establishes the baseline plan before construction and includes tracking and control feature to assess the project progress and implement corrective actions if necessary, to bring the project back on track;
4. **Genetic Algorithms Model:** Develop genetic algorithm optimization model that considers the unique characteristics of the scattered repetitive projects. This model extends the efforts by previous researchers with new formulation that considers different construction methods with their associated cost and schedule, multiple crews, different site execution orders. In addition, the proposed model updates the schedule during construction considering actual progress and as-built events to allow for proper project performance analysis and effective corrective actions;
5. **Prototype Development:** Develop a computer prototype to integrate the formulations and automate the calculations of the proposed scheduling, cost optimization, and control for scattered repetitive projects;
6. **Validation:** Once the prototype is completed, a case study of actual scattered repetitive infrastructure renewal project that commonly takes place at school boards is used to validate the system and demonstrate its benefits, usefulness, and functionality; and
7. **Modified Project Delivery Method:** Examine the advantages and disadvantages of various project delivery methods and their suitability to scattered repetitive projects. Then, a Modified Construction Management at Risk (MCMR) delivery method that maximizes the benefits of the large size and repetitive nature while minimizes the impact of the scattered nature of these projects is proposed. The introduced MCMR provides the public organizations with necessary management tools to deliver their infrastructure renewal

projects more effectively and enables the project teams to realize the benefits of the developed scheduling and control framework.

## **1.5 Thesis Organization**

The remainder of the thesis is organized as follows:

**Chapter 2** presents a detailed literature review to determine the unique characteristics of repetitive projects. The capabilities and limitations of the existing scheduling and control models are discussed. The review includes the current and emerging optimization techniques that are utilized to develop these models. In addition, the advantages and disadvantages of current project delivery methods have been described.

**Chapter 3** discusses the difficulties that public-sector organizations such as municipalities, school boards, and universities are facing to maintain and renew their deteriorating facilities infrastructure due to age and the lack of funding to provide regular maintenance. The current practices in delivering infrastructure renewal programs at two public organizations were investigated and the challenges encountering the construction teams were discussed.

**Chapter 4** introduces the proposed scheduling, cost optimization, and control framework for scattered repetitive projects that take into consideration several practical challenges identified through the extensive investigation described in chapter 3. A new graphical representation for the schedule of scattered repetitive projects is introduced. It has adequate flexibility to accurately represent various site execution orders. The chapter describes the framework capabilities in recording the as-built events during construction, incorporating these events in the schedule, and identify corrective measures. The framework uses different strategies to bring the project back on track in the event of deviating from the original plan and incorporate cost optimization calculations using GA technique.

**Chapter 5** introduces a new computer prototype system for scheduling, cost optimization and control of the scattered repetitive projects to demonstrate the usefulness of the framework and illustrate its capabilities and features. To validate the effectiveness of the introduced model, a case study for a real-life project that commonly takes place at school boards to renovate seven science labs at seven different schools is presented.

**Chapter 6** discusses the advantages and disadvantages of existing project delivery methods used by public-sector organizations to implement their infrastructure renewal scattered repetitive. The characteristics that should guide the selection of the proper delivery method are described, and the features of the required effective project delivery method are determined. An innovative project delivery method is introduced to provide public-sector organizations with effective project delivery arrangements that improve their ability to deliver this type of projects in a timely and cost-efficient manner. The perceived benefits of the new project delivery method are discussed using a real case-study.

**Chapter 7** summarizes the research works, highlights its contributions, and provides recommendations for future research.



## **Chapter 2**

### **Literature Review**

#### **2.1 Introduction**

This chapter provides an overview of the unique characteristics of repetitive projects, a review of recent literature in traditional scheduling, tracking, control; and optimization models for repetitive construction projects. The review includes a detailed description of current project delivery methods and their documented advantages and disadvantages.

#### **2.2 Repetitive Projects**

In general, repetitive projects can be classified into two broad categories: linear (such as highways, railways, and pipelines), and nonlinear (such as high-rise buildings, which are vertical in nature; and infrastructure renewal projects, which are scattered in different locations). Linear projects are repetitive due to their geometric layout, while non-linear projects repeat some activities along several repetitive units (either scattered sites or vertical floors). In linear projects, crews progress from one unit (i.e., station in a highway) to the next, from one end of the project to the other end. In non-linear projects, however, crews need to physically relocate to move from one unit (site or floor) to another. For example, a glazing crew working on a multi-school rehabilitation project would need to demobilize from one school and remobilize to another. (Hassanein and Moselhi, 2004; Duffy et al., 2011).

In repetitive projects, crews move from one unit to another, repeat the same task, and complete work that is required for other successor crews in order to start performing their repetitive tasks. This construction sequence is similar to the manufacturing assembly lines that involve repetitive tasks on products. In manufacturing, the product moves between stationary crews, while in repetitive projects, the crews are mobile and move from one unit to another.

A unit in a repetitive project could be a floor in a high-rise building, a station in a highway, a section in a pipeline, a house in a housing project, etc. (El-Rayes and Moselhi, 1998; Harris and Ioannou, 1998; Yang and Ioannou, 2004; Hyari and El-Rayes, 2006). The following subsections describe the traditional scheduling techniques for repetitive projects.

### **2.2.1 Bar Chart Method**

Bar Chart method is a graphical representation of the project schedule. It was developed by Henry L. Gantt during World War-I and since then, Bar Charts have been widely used for scheduling construction projects (Nunnally, 1998; Mubarak, 2005). In Bar Charts, activities are listed vertically, and a horizontal time-scaled bar is plotted for each activity where the length of the bar represents the duration of the activity. Bar Charts are a simple and effective tool to communicate the basic project information among parties; however, Bar Charts exhibit significant inherited limitations.

The major drawback of Bar Chart method is its inability to show the inter-relationships between activities, therefore incapable of identifying the critical activities and the critical path that determines the project duration. As such, updating the schedule as the project progresses becomes a challenging task since it doesn't consider the logical relationships between activities. Furthermore, for repetitive projects that include a large number of activities and multiple units, Bar Charts cannot display important information such as crews' movement and speed of execution. For small, non-repetitive projects, however, Bar Charts have a universal appeal because they are easy to understand by most people (Chzanowski and Johnston, 1986; Chehayeb and Abourizk, 1998; Nunnally, 1998; Arditi et al., 2002; Gould, 2005).

### **2.2.2 Critical Path Method (CPM)**

The Critical Path Method (CPM) is the most recognized and commonly used planning and scheduling technique for construction projects (Galloway, 2006; Ipsilandis, 2007). It was developed in 1956 by E. I. Du Pont de Nemours Company and since then, the use of CPM in the scheduling of construction projects has been growing (D'Onofrio, 2017). More than 95%

of the Engineering News Record's (ENR) top 400 contractors use CPM, according to a study conducted by Kelleher (2004). The use of CPM is not only limited to the ENR biggest 400 firms, but most of the small and mid-size contractors are also using CPM (Hawkins, 2007).

A CPM network diagram is a graphical representation of project activities and their relationships. It addresses the major deficiency of Bar Charts method by identifying the critical activities and the critical path that determines the project duration. The original network diagram is called Activity on Arrow (AOA) diagram and is also known as Arrow Diagram Method (ADM). In this method, arrows represent activities while nodes represent the start and finish of each activity as shown in Figure 2.1. ADM can only represent Finish to Start relationship between activities.

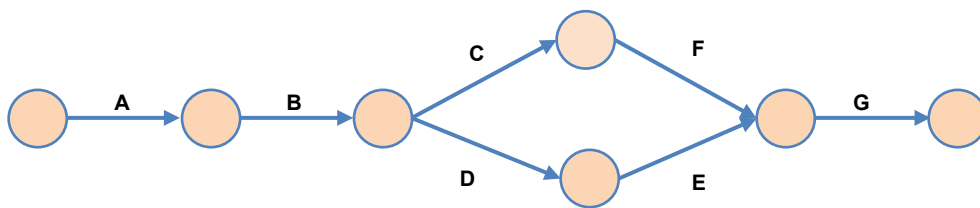

**Figure 2.1: CPM Arrow Diagram Method (ADM)**

To provide more flexibility, Activity on Node (AON) diagram, also known as Precedence Diagram Method (PDM), was developed. In this method, nodes represent activities and arrows represent the inter-relationships between activities as shown in Figure 2.2. PDM can represent more relationships between activities such as Finish to Start, Finish to Finish, Start to Start and Start to Finish (Ahuja et al., 1994; Nunally, 1998; Hegazy, 2002; Gould, 2005).

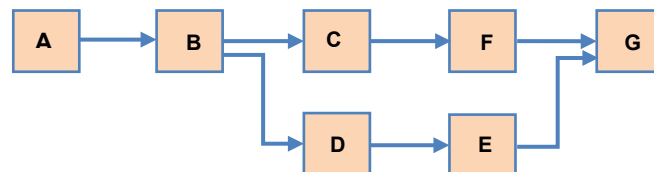

**Figure 2.2 CPM Precedence Diagram Method (PDM)**

Despite the popularity and their extensive use, CPM based methods have serious drawbacks. Most noticeably, CPM algorithm is a time driven technique, and unable to respect a given deadline or practical limitations of resources. CPM techniques assume that required resources are always available, and therefore, they often produce schedules with more resources needed than available. The CPM formulation also often results in large daily fluctuation of resources, and as a result, individual resource-leveling efforts are required to improve resource utilization and to avoid excessive hiring and firing of resources. Besides, CPM methods do not consider project cost optimization aspects in their formulation (Hegazy, 2002; Ammar, 2013).

These limitations become even more apparent when applied to projects with repetitive nature. To represent the CPM network for repetitive project graphically, an individual element (arrow or box) is required for each repetitive activity, which results in a complex network. A typical CPM network for three units project is shown in Figure 2.3. The solid arrows represent logical relationships for activities within each unit, while the dashed arrows represent sequence relationships among the repetitive units. The number of relationships needed to describe the network is considerably large, which makes it difficult for the project team to visualize and understand the project schedule. The benefit of such a network in describing the sequence of activities is significantly reduced because a simple repetitive project with three units produces disproportionately large and unnecessarily complex network. Furthermore, the CPM network is unable to represent the resources required to complete a project and how these resources move between repetitive units (Harris and Ioanno, 1998; Senior and Halpin, 1998; Ipsilandis, 2007; Su and Lucko, 2016).

The limitations of CPM based techniques and their inability to model repetitive projects have been widely recognized in the literature. Repetitive activities in projects with repetitive nature often have different production rates. This imbalance in productivity rates has the potential to hinder the project performance by causing inefficient utilization of available resources. Maintaining work crew continuity is an essential aspect of repetitive projects to minimize interruption and idle time for labor and equipment, and to maximize the benefit of the learning

curve. CPM techniques plan the start of each activity immediately after the completion of all predecessor activities without considering the production rate of each crew in the analysis, and as a result, the work continuity cannot be maintained. This causes a faster crew to remain idle until all the predecessor activities that utilize crews with slower production rates are complete. Such an inefficient utilization of resources will cause additional time and cost to the project (Arditi et al., 2002; Fan and Tserng, 2006; Su and Lucko, 2016).

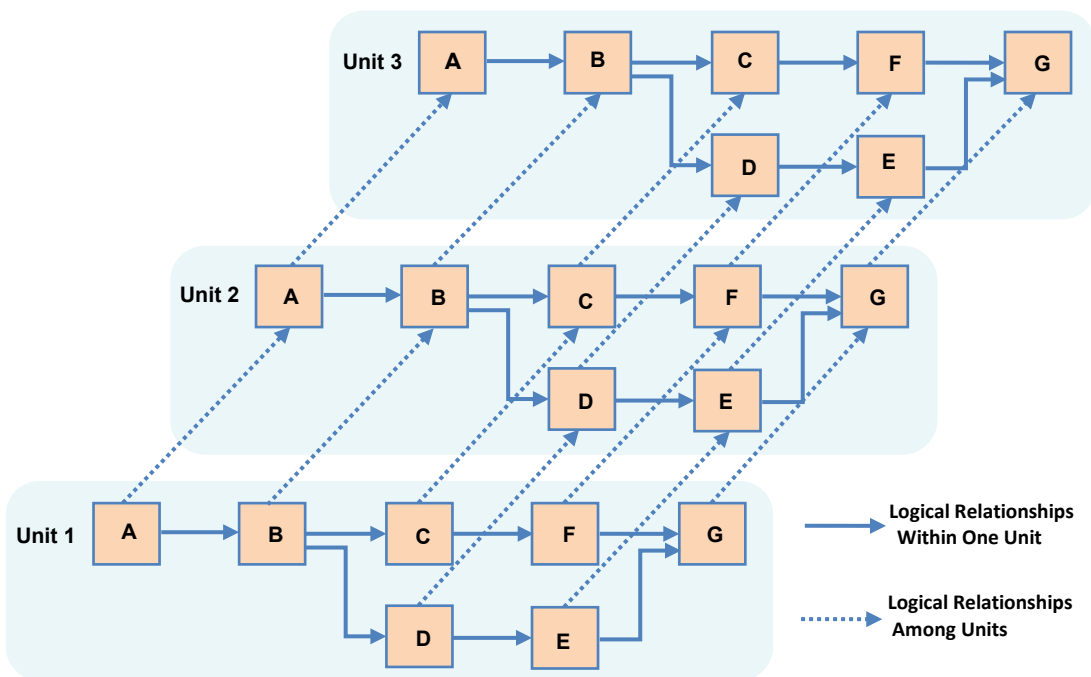

**Figure 2.3: Network Diagram for Three Unit Project (Based on Suhail and Neal 1994)**

Furthermore, CPM network methods are unable to accommodate multiple crews' strategy which is an essential aspect of large construction repetitive projects; are incapable of monitoring the project progress; do not effectively represent repetitive tasks in a distinctive manner as all tasks are represented similarly; and do not present the location where the work is currently performed in the schedule (Adeli and Karim, 1997; Mattila and Park, 2003).

### **2.2.3 Scheduling Techniques for Repetitive Projects**

In recognition of the disadvantages and limitations of Bar Charts and CPM techniques when applied to repetitive projects, alternate techniques have been developed in the last several decades. Such methods have attempted to tackle some of various problems associated with scheduling repetitive projects, including synchronizing resources and maintaining work continuity among repetitive units; introducing proper work interruption to achieve a balance among the production rates of repetitive activities; achieving a desired progress rate to meet project deadline; sequencing execution of work locations; incorporating non-repetitive activities within repetitive projects; learning curve effect; and presenting the schedule in a clear and easy-to-use format (Reda, 1990; Suhail and Neale 1994; El-Rayes and Moselhi, 1998; Thabet and Beliveau, 1997; Harmelink and Rowings, 1998; Harris and Ioanno, 1998; Hegazy and Wassef, 2001; Arditi et al., 2002; Hassanien and Moselhy, 2004; Hairy and El-Rayes, 2006; Tokdemir et al., 2006; Ipsilandis (2007); Hegazy and Kamarah, 2008; Ammar, 2013; Dolabi et al., 2014; Su and Lucko, 2016).

### **2.2.4 Line of Balance (LOB)**

The Line Of Balance (LOB) technique was introduced by the Goodyear Company in the early 1940s and was further developed by the U.S. Navy in 1952 for scheduling and control of repetitive and non-repetitive projects. LOB was first applied to industrial manufacturing applications to assess the output of production lines (Arditi et al., 2001; Yang and Ioannou, 2004). In the 1960s, the LOB was further modified and applied to repetitive housing projects by the National Building Agency in United Kingdom (Lumsden, 1968). They used a simple graphical chart for serial repetitive activities (i.e., no network analysis) that uses time on the horizontal axis and the repetitive unit on the vertical axis, as shown in Figure 2.4. The chart shows a typical LOB schedule for three sequential activities and the crew movement among different units. Activity A, for example, uses two crews; crew 1 starts at unit 1 then moves to unit 3 and 5, while crew 2 starts at unit 2 then moves to unit 4.

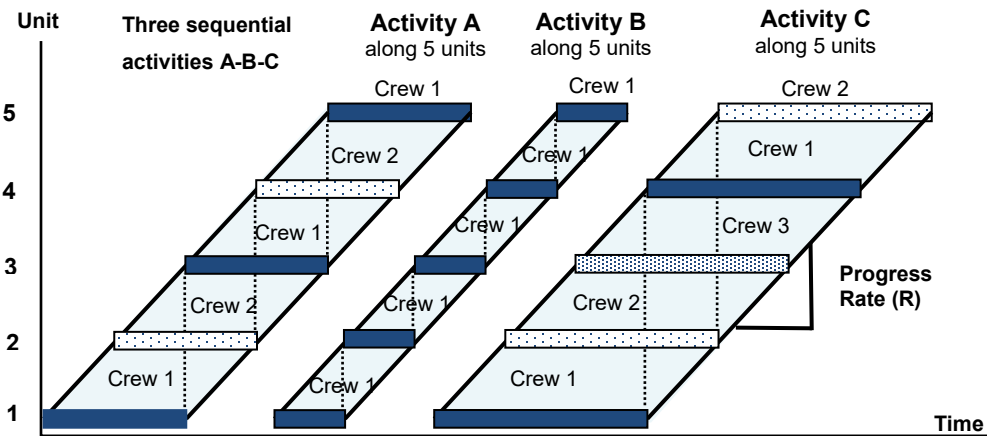

**Figure 2.4 LOB Schedule Representation of Three Activities along Five Units**

A key advantage of LOB over CPM is its ability to display at glance a comprehensive overview of the project speed by plotting the start and finish time for each activity at each unit and showing the movement of crews among the repetitive units. It is noted, however, that LOB method only considers sequential activities and is only suitable for simple small repetitive projects. In addition, LOB does not consider variable production rates due to the variation of work quantities among repetitive units. Therefore, it is not suitable to schedule the non-typical activities which constitute most of the repetitive activities in projects with repetitive nature (Moselhi and El-Rayes 1993; Suhail and Neale 1994).

To address some of LOB drawbacks, Johnston (1981) introduced the Linear Scheduling Method (LSM) where activities are plotted versus two axes, one axis represents repetitive units, and the other represents time. The activities are plotted as lines with either constant or changing slope that represents the productivity rate as shown in Figure 2.5. The main advantage of the LSM over LOB is its ability to represent non-typical activities. However, the LSM as presented by Johnston (1981) cannot properly represent non-repetitive activities and is mainly a graphical method that lacks numerical computation capabilities (Chrzanowski and Johnston, 1986).

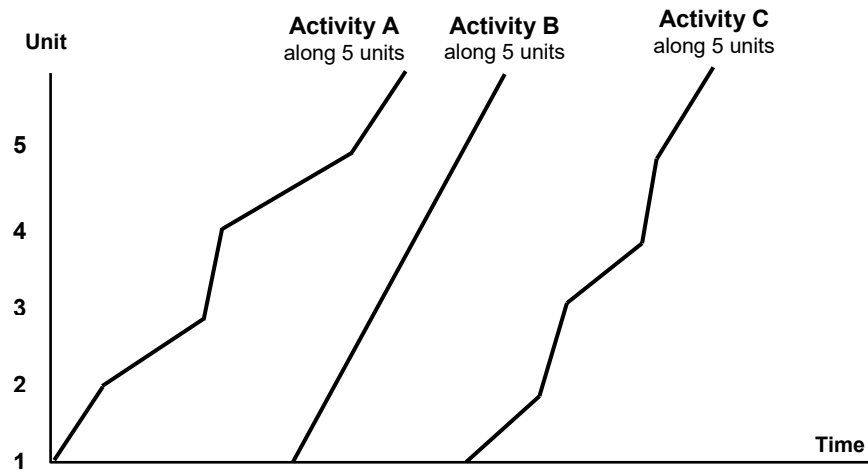

Figure 2.5: LSM Representation of Three Activities along Five Units

### 2.2.5 Combined Analytical and Graphical Scheduling Methods

Since their introduction, several efforts in the literature have introduced improvements and analytical enhancements to LOB and LSM. Harris and McCaffer (1989) developed a six-step procedure for preparing LOB schedules. They suggested various techniques to improve the resource utilization, which includes overlapping of activities, changing production rates, and laying off and recalling crews during construction. Al-Sarraj (1990) presented a mathematical model for LOB technique. The model calculates the start and the finish times for repetitive activities at each unit. The model provided an alternative for drawing the LOB diagram to define the schedule. Suhail and Neale (1994) developed a model to combine the critical analysis of CPM and the graphical advantages of LOB for repetitive projects scheduling. They developed a formulation to calculate the required number of crews to meet a given deadline. The model formulation incorporates the resource leveling principles and the activities' total float values to relax non-critical activities while meeting the project completion date. Despite the obvious advantages of this model, it does not consider the impact of various progress rates due to crew roundup, and therefore maintaining crew work continuity cannot be guaranteed.



Tokdemir et al., (2006) introduced Advanced Linear Scheduling System (ALISS) to schedule and calculate the total cost of linear projects. The system utilizes MS Access and SQL server as data depository. The model, however, doesn't consider multiple resources and requires the installation of an expensive software. Ammar (2013) introduced an integrated CPM and LOB model to schedule repetitive projects. The model maintains work continuity while considering logical dependency and resources availability constraints. It overlaps the activities of a typical unit to represent the logical relationships between activities among the repetitive units. The model, however, doesn't consider the learning curve effect or work interruption, and only considers typical activities with constant durations. Dolabi et al. (2014) presented an improved CPM/LOB scheduling methodology. They introduced Heuristic Line of Balance (HLOB) that satisfies deadline constraints despite the roundup of the number of crews for projects with serial repetitive activities.

El-Rayes and Moselhi (1998) introduced resource-driven scheduling model for repetitive projects. The model utilizes multiple crews, maintains work continuity, ensures crew availability while satisfies the precedence relationships between activities and considers user specified execution order for various activities. In 2006, Hayri and El-Rayes introduced a multi-objective optimization model for scheduling the construction of repetitive projects. The model objectives are to minimize the project duration and to maximize resource utilization by establishing the optimal tradeoffs between the project duration and crew work continuity. Subsequently, Hayri et al. (2009) developed a bi-objective model to minimize the project cost and the project duration; and to establish an optimum tradeoff between duration and cost for repetitive projects. The model produces near-optimum solutions, each has its unique duration, direct cost, crews' productivity, and interruption.

Harmelink 1995 and Harmelink and Rowings (1998) developed controlling activity path (CAP) for Linear Scheduling Model (LSM) to provide analytical capability to the linear scheduling process. The LSM identifies the controlling activity path (similar to critical activities in CPM) that controls the project duration through upward pass and downward pass. They concluded that unlike the CPM, an activity can change from noncontrolling to controlling

at different locations along a linear activity. Harris and Ioannou (1998) introduced Repetitive Scheduling Method (RSM) to establish a controlling sequence using control points. The RSM represents each repetitive activity graphically as a production line in an XY plot using control points to identify the controlling sequence of activities that determines the project duration. Zhang and Qi, (2012) reported that some of the proposed models to identify controlling path for repetitive projects may produce different controlling paths for the same repetitive project and the process by which controlling segments determine the project duration is not easy to understand. Zhang and Qi (2012) presented a modified method to determine the controlling path and controlling segments. They defined the controlling path in a repetitive project as “the longest path in duration that determines the minimum project duration”.

Ipsilandis (2007) presented multi objective linear programming model for scheduling linear repetitive projects. The model integrates work interruption and investigates the cost implication of such interruption. Furthermore, the model provides an alternative schedule solution in addition to the solution defined by minimum project duration or maximizing resources utilization. Duffy et al. (2011) introduced a Linear Scheduling Model with Variable Production Rates (LSMVPR). The model examines and determines the impact of changes in production rates in a graphical format to predict and visualize obstacles in the project when and where they occur. Tang et al. (2014) introduced two-stage scheduling models for resource leveling of linear projects to calculate optimal or near-optimal schedules. In an interesting effort, Su and Lucko (2016) combined the benefits of the mathematical formulation of LSM and the graphical advantages of the LOB to develop scheduling for repetitive projects utilizing multiple crews to shorten the total project duration.

Several efforts in the literature developed scheduling and cost optimization models for vertical repetitive projects such as high-rise buildings. Laramee (1983) developed a model for scheduling the high-rise projects that combined the Precedence Diagram Method (PDM) with linear planning. The model considers repetitive and non-repetitive activities, and repetitive activities with different durations (i.e., non-typical activities). The model formulation, however, doesn't include the construction cost.

Thabet and Beliveau (1994, 1997) used a knowledge-based system to develop a Horizontal and Vertical Logic Scheduling (HVLS) model that incorporates horizontal and vertical constraints for high-rise building projects. The model considers work continuity to reduce idle waiting intervals of equipment and workforce, minimizes work interruptions, and maximize the learning curve. Then, (HVLS) was enhanced with a Space-Constrained Resource-Constrained Scheduling System to address the problem of limited space availability and account for resource constraints. The model, however, doesn't consider repetitive and non-repetitive activities simultaneously.

Shaked and Warszawski (1995) introduced a knowledge-based system for the construction planning of high-rise buildings. The system uses an object-oriented representation to generate modular zones, construction activities, dependencies between activities, and efficient resource allocation. Arditi et al. (2002) developed a Computerized High-Rise Integrated Scheduling System (CHRISS) that utilizes resources productivities database with a knowledge-based expert system to generate schedules for high-rise building projects. CHRISS produces optimum solutions to utilize the resources efficiently with minimum idle time.

These models are useful for scheduling high-rise projects; however, special considerations for practical horizontal and vertical relationships were not adequately addressed and cost optimization was least developed. To address these drawbacks, Hegazy and Kamarah (2008) introduced an efficient scheduling and cost optimization model for high-rise construction that incorporates several practical constraints usually encountered during the construction of high-rise projects. The model pays particular attention to the scheduling of the structural core activities (columns, beams, and slabs) to avoid common scheduling errors in regard to the scheduling of the framing activities. The model objective is to minimize the construction cost while respecting given deadlines and resources constraints, maintaining work continuity among repetitive floors, considering a variation of work amount between floors, and the impact of productivity factors such as weather conditions and the learning curve on crews' productivity.

Among the limited efforts to schedule scattered repetitive projects, was the work by Hegazy et al. (2004) and Hegazy (2006). They introduced a basic scheduling model for multiple sites with a Genetic Algorithms (GA) procedure to optimize the schedule. A key assumption in their model is that the order of execution is the same for all activities. This may not be suitable for all situations and doesn't provide the project team adequate flexibility to efficiently utilize the resources and adapt the crew's movement to the requirement of individual activities. For example, the order of execution for interior flooring work among different sites does not need to follow the same order as landscaping tasks because they are two independent tasks, which is addressed in this research in respect to scattered repetitive projects. In addition, the model doesn't adequately address the tracking and control phase of the project. However, their handling of scattered sites is interesting, and its drawbacks will be addressed in this research. To consider uncertainty in scheduling scattered projects, Ezeldin and Soliman (2009) proposed a scheduling model to optimize time-cost tradeoffs under uncertainty for non-serial projects. However, the model does not account for local productivity factors and doesn't include the moving time and cost between sites in the total project duration and cost.

Despite interesting and useful features of the above models for scheduling of repetitive projects, special considerations for the challenges of scattered repetitive projects are lacking. Most of the existing models do not adequately account for productivity factors such as the impact of working on occupied facilities on crews' productivity and do not include the time and the cost of moving crews among scattered sites in the project calculations. The existing methods do not represent the scattered repetitive projects in a legible and easy to understand format, particularly when each activity follows an independent site execution order. Moreover, incorporating progress events during construction to allow proper performance analysis and implement necessary corrective actions to facilitate effective project control are not adequately addressed.

### **2.3 Project Tracking and Control Methods**

Project tracking and control is a process that aims at ensuring the project's objectives are met by the project team in terms of design requirements, budget, and schedule. It involves the techniques, methods, tools, and styles of implementation used to control the time, cost and quality of a project (PMBOK Guide 2013). It usually consists of two components (a) Tracking which refers to the process of monitoring deviations from the original plans during the course of the project; and b) Control which refers to the identification of corrective actions necessary to alleviate such deviations. If any of the project objectives begins to deviate from the original plan, the project control system should identify this deviation and allow a correction to be made. Therefore, an effective tracking and control system is essential to the successful delivery of a construction project (El-Rayes et al., 2002; Moselhi et al., 2003; Li, 2004). During construction, large volume of as-built information related to scheduling, cost management, construction methods, quality control, change order management, progress draws, and actions by different parties are generated (De La Garza and Howitt, 1998; Scott and Assadi, 1999).

Project tracking and control is a major challenge due to serious drawbacks with current progress tracking and control systems. Olawale and Sun (2014) reported that many existing control models focus on describing the processes and the tasks of project control more than how these tasks should be conducted. Besides, the majority of literature efforts on repetitive projects focus on project planning before the construction starts as opposed to project control and scheduling update during construction. Therefore, a gap exists between the theoretical principals of these methods and the project control practices. They concluded that these drawbacks of existing control techniques and difficulties in implementing them are partially responsible for the common schedule delays and cost overrun of construction projects. Furthermore, the currently available tools for project tracking and control are CPM based and their shortcomings have been widely recognized in the literature. CPM calculation is unable to accommodate optimization techniques to determine optimum schedule before construction or corrective actions during construction (Hegazy and Menesi 2010).

**Earned Value Method (EVM)** is one of the earliest attempts to provide quantitative measures for evaluating project progress and is the most commonly used method of project performance measurement (PMBOK Guide, 2013). The methodology was first introduced in 1960s within the United States Defense Department projects and since has been a widely used commercial tool (Batselier and Vanhoucke, 2015). The key feature of EVM is its unique performance measures and forecasting indicators. It measures two project variances and two performance indices; the cost performance variance (CV); the schedule performance variance (SV); schedule performance index (SPI); and cost performance index (CPI). Figure 2.6 illustrates the typical EVM formulas to calculate CV, SV, SPI, and CPI at any specific point during construction using a hypothetical example. Cumulative costs are calculated and plotted as following (Hegazy, 2002):

- *Budgeted Cost of Work Scheduled (BCWS)*: measures budget cost for planned work;
- *Budgeted Cost of Work Performed (BCWP)*: measures budget cost for work completed to date; and
- *Actual Cost of Work Performed (ACWP)*: measures actual cost of work completed to date.

The performance measures are calculated based on BCWS, BCWP, and BCWA values to date. In the example of Figure 2.6, the project exhibits schedule delay as the schedule variance (SV) value is less than zero and cost overrun as the cost variance (CV) value is less than zero, which provides warning signs and mandates corrective actions. To estimate the final cost at different stages of the project, the Estimate at Completion (EAC) is calculated as follows:

$$EAC = BCWS \text{ at completion} + (ACWP - BCWP) \text{ at present}$$

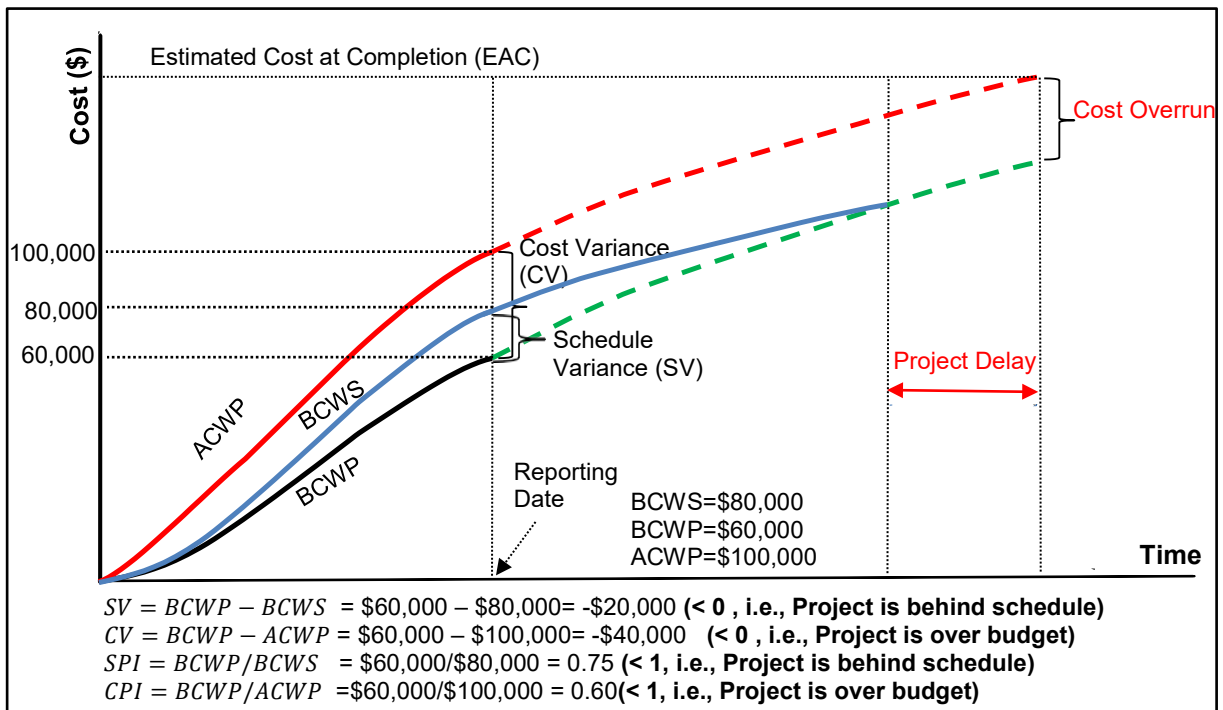

**Figure 2.6 Earned Value Method Representation and Analysis (Based on Chou et al. 2010)**

Despite its popularity, the EVM has serious shortcomings. An important drawback is that the project schedule variance (SV) is evaluated based on cost values and not on time values which makes it difficult to understand and interpret. Moreover, the SV always converges to 0 and the SPI converges to 1 towards the end of the project, which gives a false indication that the project is on time and on budget even if it is not the case. As a result, the SV and the SPI become inaccurate indicators (Lipke 2003; Vandevoorde and Vanhouche, 2006).

In recognition of EVM disadvantages, several researchers have introduced enhancements to the EVM. Lipke (2003) introduced Earned Schedule Method (ESM) that uses a time measure to calculate schedule variance  $SV_{(t)}$ . At project completion,  $SV_{(t)}$  equals the project delay at completion as opposed to SV of the EVM that always ends at zero. The same applies to the  $SPI_{(t)}$  indicator, which has a final value that reflects the final project schedule performance as opposed to the SPI that always equals 1. In 2011, Vanhoucke developed Monte-Carlo simulation to study the efficiency of project control techniques using EVM and the ability to

initiate corrective actions. Narbaev and De Marco (2014) proposed a model to enhance the ESM and EVM techniques' abilities to calculate the project Cost Estimate At Completion (CEAC). Hanna (2012) experimented EVM at different intervals throughout the project duration to provide an accurate forecast of work-hours at completion for electrical contractors. These modifications to EVM are important, however, EVM is unable to explain causes of the variances and accordingly cannot determine required corrective actions (Alshaibani, 1999). Moreover, The EVM does not adequately accommodate the special nature of scattered repetitive projects.

Several project management packages were introduced since the 1980s. Most popular are Microsoft Project and Primavera Project Planner. These programs provide tools for project scheduling and tracking. However, they are CPM based and are not suitable for projects with repetitive nature. Recent scheduling systems for repetitive projects such as Vico and Tilos are suitable for developing a detailed schedule for the planning phase (Vico Software Integrated Construction 2015; Tilos Linear Project 2015). However, the project control and the cost optimization capabilities of these tools are not adequately developed.

Several research efforts have been conducted in the last three decades to develop progress tracking and control of construction projects. One of the earliest efforts was Eldin and Senouci (1994) that used two-state-variable, N-stage dynamic programming to develop scheduling and control model for linear projects. The model allows introducing interruption while attempting to maintain the work continuity with the objective to minimize the total project costs. In an interesting effort, El-Rayes et al. (2002) presented an object-oriented model for planning and control of housing projects that considers non-repetitive activities and multiple crew's utilization at three levels: entire project; particular housing unit; and individual subcontractor. The model allows the user to specify the execution order for activities along the repetitive houses. Hegazy and Petzfold (2003) integrated a spreadsheet with commercial project management software to develop a dynamic project control that uses resource depository for estimating, scheduling, and resource management. In a subsequent effort, Hegazy et al. (2014) used an automated email-based system to collect site progress data and update the schedule for



linear projects. Moselhi et al. (2004) introduced web-based Integrated Time and Cost Control system (IT/CC) for construction projects. The system incorporates the project WBS into an object-based model to produce earned value-based project progress reports.

Hwang and Liu (2005) developed Proactive Control method (Pro-Con) that integrates the field productivity data with historical productivity data to better predict the project performance. Cho et al. (2010) proposed an integrated schedule and cost model for planning and control of repetitive projects. They modeled the core wall construction in high-rise projects to enable project managers to make informed decisions during the construction. In 2014, Bakry et al. introduced an algorithm for schedule updating and re-scheduling for repetitive projects by determining the optimized acceleration strategies with minimum cost. The model maintains work continuity and considers non-repetitive activities. The model, however, does not consider the impact of productivity factors on the working crews and does not benefit from the learning curve.

Recently, several efforts combined the 3D CAD model with emerging technologies such as Radio Frequency Identification (RFID) and Geographical Information System (GIS) to collect and present project progress data. Chin et al. (2005) introduced 4D CAD + RFID for project progress tracking to present building elements in 3D CAD models to reflect as-built progress. The 4D+RFID focuses on critical activities such as structural and curtain wall elements in high-rise projects. The RFID measures the progress status of constructing various building elements and then presents the collected as-built progress information in 3D model. Poku and Arditi (2006) introduced Progress Monitoring System with Geographical Information System (PMS-GIS) to collect and present the project progress. The system combines CPM schedule and graphical representation of the construction. Similar to the Chin et al. model, the (CAD) program is used to develop the drawings while the schedule is generated using Primavera (P3). The schedule progress information is collected, entered to GIS package, and at the reporting day, the system produces 3D drawings of the project progress in addition to CPM based bar chart schedule. French et al. (2008) introduced 4D CAD model that combines linear planning with a 3D CAD to produce 4D CAD images.

Bansal and Pal (2009) integrated GIS with a 4D model for visualizing and reviewing the construction project progress. Similarly, Liang et al. (2011) developed 4D-Positioning Controller (4D-PosCon) to track and visualize the erection of building components during construction. Despite the advantages of tracking construction progress using 3D CAD models, these systems still cannot produce progress as-built without extensive human efforts and cost a significant amount of money (Son and Kim, 2010).

The above-described efforts are important and provide useful tools to better plan and manage construction projects; however, the ability to record and integrate the daily as-built events to provide a realistic assessment of the project status is lacking. Therefore, the task to identify effective corrective actions to alleviate any deviation from the original plans becomes significantly challenging. Moreover, the unique challenges for infrastructure rehabilitation scattered repetitive projects are not adequately addressed. Olawale and Sun (2014) reported that many efforts have discussed the mathematical and diagrammatical aspects of an ideal project control process. These models, however, were developed without adequate feedback from the project management practitioners to ensure their practicality. There is an essential need for a model that can identify potential corrective actions, and more importantly, to show the impact of implementing these corrective actions on the total project cost and duration.

**Critical Path Segment (CPS):** Existing scheduling and control tools typically represent the duration of each activity as a continuous block of time, and the actual progress to date is represented as a cumulative percentage complete. During construction, daily progress events cannot be properly recorded on the schedule, and therefore significant efforts are required to identify corrective actions and to update the schedule (Hegazy and Menesi, 2012). In an attempt to incorporate mid-activities events and interruptions in the schedule, Stumpf (2000) divided activities into sub-activities and added more relationships to conduct proper delay analysis and identify responsible parties. This approach increases the number of activities and results in a complicated schedule that requires significant efforts to update.

To address these challenges, to simplify the schedule updating task, and to improve project control, Hegazy and Menesi (2010, 2012) introduced the Critical Path Segments (CPS) approach that has a much richer representation of the schedule with mid-activity details than traditional CPM and Bar Charts. CPS divides each activity into consecutive time segments, each segment is usually one day, that add up to the total duration of the activity. CPS documents and visualizes mid-activity progress events on each segment during construction. Each segment shows the speed of construction at its specific schedule date and can represent events by different parties in the project. CPS incorporates as-built information to facilitate corrective actions and determine the responsibility of various parties for any delays that may occur. The technique was also used by other researchers (Tang and Mukherjee 2012) to compute accurate criticality indexes for project activities.

Due to its rich representation and its computation capabilities, this study extends the CPS to the environment of infrastructure renewal scattered repetitive projects. The CPS will be enhanced to develop scheduling and control framework that considers the complex nature of scattered repetitive projects to enable more accurate project performance analysis and facilitate more effective corrective actions.

## **2.4 Optimization Models**

Developing a schedule, control, and cost optimization model to meet project time and cost constraints is a challenge. Mathematical models such as linear and non-linear programming can be applied to find an exact single solution; however, they are challenging to develop and maintain, and require significant computational efforts. Recent development in Artificial Intelligence (AI) technology has produced numerous tools for construction management applications. The aspiration to effectively optimize large scale and complicated problems has motivated many researchers to develop non-traditional problem-solving tools based on artificial intelligence for scheduling and cost optimization of large-size projects. Evolutionary Algorithms (EAs) such as Genetic Algorithms (GA) have become increasingly popular in

science and engineering and have proven to be capable of arriving at near-optimal solutions for large scale problems (Li and Love, 1997; Hegazy, 1999; Leu and Yang, 1999; Zheng et al., 2004; Elbeltagy et al., 2005; Huang et al., 2016). An introduction to these techniques and their applications in repetitive scheduling is discussed in the following sub-sections.

### **2.4.1 Mathematical Techniques**

Traditionally, mathematical models utilized either linear or dynamic programming procedures to find optimum solutions for scheduling and optimization of repetitive and non-repetitive projects. One of the earliest attempts to use dynamic programming approach for linear construction projects was presented by Selinger (1980) introducing a dynamic programming model for scheduling repetitive projects. The model objective is to minimize the total project duration; however, the model does not consider construction cost in its formulation. Russel and Caselton (1988) extended Selinger's model and introduced a two-state variable,  $N$ -stage dynamic model for linear scheduling. The two state variables represented the duration and the interruption for each activity. The model objective is to minimize the project duration and maintain work continuity; however, the cost is not considered in the model calculations. Reda (1990) introduced the repetitive project model (RPM), a linear programming model for scheduling repetitive projects. The model objective is to minimize the project direct cost. The model assumes linear time-cost relationships and does not allow work interruptions. Moselhi and El-Rayes (1993) used dynamic programming model to produce optimum project duration while minimizing the project total cost. The model identifies optimum crew formation for each repetitive activity and evaluates the impact of different acceleration methods such as overtime and additional shifts on the project overall cost. Senouci and Eldin (1996) proposed dynamic programming model to minimize the total construction cost. The model is capable of scheduling serial and non-serial projects, considering different crew formations, performing time-cost trade-off, and maintaining work continuity.

Despite the advantages of these models, the mathematical optimization techniques such as linear and dynamic programming, require a great deal of computational effort and therefore, they are only suitable for small-size projects. Due to the large size and complexity, developing a mathematical model for solving large size construction management problems is difficult and expensive. Moreover, they do not guarantee a global optimum solution and are likely to determinate at local optimum solutions (Li and Love, 1997; Hegazy, 1999; Leu and Yang, 1999; Cheng and Ko, 2003). As a result, efforts in the literature have used non-traditional Artificial Intelligence optimization techniques such as Genetic Algorithms to address large size construction management problems.

#### **2.4.2 Artificial Intelligence Techniques: Genetic Algorithms (GA)**

GA is a stochastic random optimization method for solving large scale problems that employs a random search for locating optimal or near-optimal solution (Chen and Ko, 2003; Fan et al., 2012). GA was developed as a non-traditional optimization method to simulate the natural evolutionary process presented by Charles Darwin of “survival of the fittest”. Potential solutions to a given problem are represented as a population of chromosomes and each chromosome consists of a series of genes that represent the values of the variables associated with each solution. The fitness of each chromosome is determined by evaluating its performance with respect to the objective functions. The chromosomes with better fitness will have higher probability to survive and to be selected to exchange information through crossover to produce new offspring chromosomes, or to be modified through mutation. Crossover is the process by which chromosomes exchange their desirable qualities (information) to produce offspring solutions as shown in Figure 2.6. The two parent chromosomes are randomly selected in a manner that the probability of being selected is proportional to their relative fitness to ensure that better chromosomes are selected in the process while maintaining the randomness. The population continuously evolves by replacing the weaker members with new offspring chromosomes if they have better fitness. This process continues for a large number of generations to obtain the optimum or near-optimum solution. Mutation, on the other hand, is a rare process in which one chromosome is randomly selected

from the population and some of its information are altered to avoid stagnation around local optimum solution (Li and Love, 1997; Hegazy, 1999; Leu and Yang, 1999; Senouci and Eldin, 2004; Zheng et al. 2004; Elbeltagy et al., 2005; Fan et al., 2012).

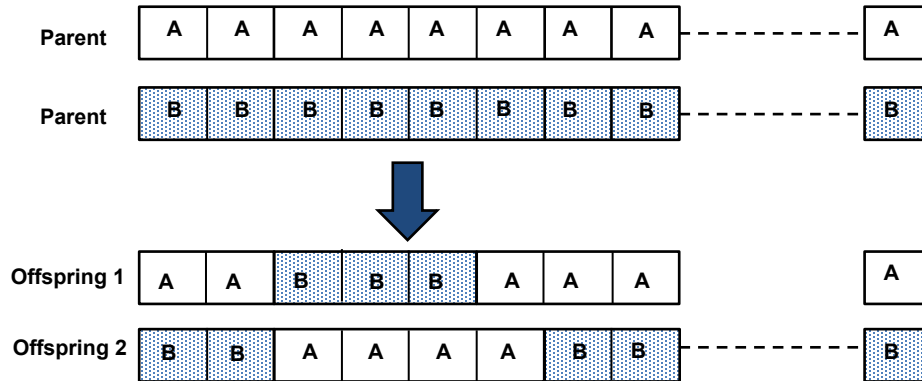

**Figure 2.7: Crossover Operator to Generate Offspring Chromosomes (Elbeltagy et al., 2005)**

The main advantage of the genetic algorithm is its ease of implementation and its effectiveness at global search. It operates on a population of chromosomes, searches and exchange information between multiple peaks, therefore, increasing the likelihood to arrive at a global optimum solution and reducing the possibility of ending at a local optimum solution. For these advantages, and for their potential as a novel optimization technique, GA's have become increasingly popular and have been used successfully to solve several engineering and construction management problems, including time-cost tradeoff, resource leveling and resource allocation (Li and Love, 1997; Hegazy, 1999; Leu and Yang, 1999; Cheng and Ko, 2003; Zheng et al. 2004; Fan et al., 2012).

Hegazy (1999) used genetic algorithms to search for near-optimum resource allocation and leveling simultaneously by introducing random priorities into selected tasks and monitoring their impact on the schedule. The model determines the best combination of construction methods to meet the deadline with minimum construction cost. Leu and Yang (1999) proposed a genetic algorithm-based multi-criterion scheduling model that incorporates the time-cost trade-off and resource-leveling. They attempt to provide an optimal combination of duration

and utilized resources, to minimize the project direct cost and duration while satisfying the limited resources constraint. To address the resource-constrained scheduling problem, Senouci and Eldin (2004) proposed a genetic algorithm model that considers multi-crew strategies, and time-cost trade-off to minimize the total project costs. In a similar effort, Zheng et al. (2004) utilized genetic algorithms to develop a model for time-cost optimization. The model uses previous information to adjust the search direction to produce a solution that optimize the total cost and total duration simultaneously.

Several efforts in the literature used Genetic Algorithm to optimize repetitive construction projects cost and duration. In 2001, Hegazy and Wassef introduced a genetic algorithm-based model for scheduling and cost optimization of repetitive projects with serial and non-serial activities. The model objective is to minimize the total construction costs (i.e. direct and indirect costs) while meeting a specified deadline. The model considers alternative construction methods with their associated durations and costs to determine the optimum time-cost trade-off solution. In 2008, Long and Ohsato used genetic algorithm to develop a multi-objective model for scheduling repetitive projects to optimize the project duration and the project cost. The model considers precedence relationships between activities and resource work continuity constraints. However, it assumes the same production rate for each activity at all units and only considers one working crew.

Fan et al. (2012) developed a genetic algorithm optimization model to generate optimal schedules for repetitive projects to determine the minimum total cost. The model incorporates the cost as a decision variable and takes soft logics into consideration in the optimization process. They defined the soft logic method as “Scheduling with non-fixed work sequence between work zones”. Damci et al. (2013) introduced a GA-based multi-resource leveling model for LOB schedules to optimize the crew sizes and maintain work continuity. In 2016, Huang et al. developed a genetic algorithm to solve the multimode discrete time-cost trade-off problem considering soft logic. The model objective is to determine activity modes, start time, and the best sequence between units with minimum total cost while meeting a given deadline. The model, however, can only utilize one crew and does not consider multiple crews’ option.

GA-based models have been used successfully to solve several construction management problems for repetitive and non-repetitive projects. However, the existing GA-based scheduling models do not adequately address the unique characteristic of the infrastructure renewal scattered repetitive projects, particularly the scattered nature, the local productivity conditions at each site, the moving time and cost, and the proper activity specific site execution order of working crews simultaneously. Furthermore, the tracking and control features of these models are lacking and incapable of incorporating the daily progress events of all parties, to facilitate performance analysis and corrective actions, which is addressed in this research.

## **2.5 Project Delivery Methods (PDM)**

A *Project Delivery Method (PDM)* is the process of assigning roles and responsibilities to parties involved in designing, procuring, and constructing a project. It establishes contractual structure and compensation arrangement to achieve successful completion of a construction project from inception to completion. It describes the project execution framework that includes defining the project scope, identifying timelines and procedures to engage the project major players (i.e. designers and constructors), managing the project schedule and budget, and sequencing of design, procurement, and construction phases. The PDM defines the contractual relationships between the project parties and allows owners to allocate the delivery risks to other parties, namely the consultant who takes responsibility for the design and the constructor who takes responsibility for the construction (Williams, 2003; Mahdi and Alreshaid, 2005; Oyentunji and Anderson, 2006; Touran et al., 2011; Chen et al., 2011; Shrestha et al., 2012 El-Asmar et al., 2013; Carpenter and Bausman 2016).

Historically, most of the large-scale construction projects from Pyramids to Eifel Tower, were constructed using a master builder approach, in which a single entity would perform the duties of the architect, engineer, and contractor. This delivery method was common until the early 20<sup>th</sup> century. The continuous evolution and increasing advancement in building materials and technologies required the separation of design and construction services. Because of this separation, different, and sometimes conflicting interests of the project parties complicated the



communication and the decision-making process during the execution of the project. This led to the development of the traditional Design-Bid-Build (DBB) delivery system. However, because of the inherited limitations and widely recognized drawbacks of DBB, more integrative and collaborative project delivery methods have evolved to suit sophisticated modern projects and changing owners needs such as Design-Build (DB) and Construction Management (CM). The selection of the most suitable project delivery method for a project is an important decision that significantly impacts the success and the effectiveness of the project execution as roles, responsibilities, and inter-relationships among the project parties vary under different project delivery methods. Each has its advantages and disadvantages, and its appropriateness for each project should be carefully evaluated. (Konchar and Sanvido, 1998; Oyentunji and Anderson, 2006; Mafakheri et al., 2007; Friedlander, 2011; BCCA, 2012; Carpenter and Bausman 2016; Liu et al., 2016; Sullivan et al., 2017). Several studies have discussed these methods and presented the advantages and disadvantages of each PDM as discussed in the following sub-sections.

### **2.5.1 Design – Bid – Build (DBB) Delivery System**

This project delivery method is the “traditional” method for delivering construction projects and is the most frequently used delivery method. As shown in Figure 2.8, DBB creates a clear separation between the design and construction processes and clearly defines the roles of parties involved. When DBB is utilized, the owner hires a consultant (Architect/Engineer firm A/E) to prepare the project documents, including the drawings and specifications. Upon the completion of the design, the tender package is presented to interested contractors, who evaluate the project documents and submit lump-sum prices. The A/E team is responsible for answering bidders’ questions during the tender and assisting the owner in evaluating received bids. Typically, for the most of public-sector projects, the owner awards the contract to the contractor with the lowest compliant bid. The selected contractor hires suppliers and sub-contractors to construct various components of the project (Alkhalil, 2002; Mafakheri et al., 2007; Hale et al., 2009; CMAA, 2012).

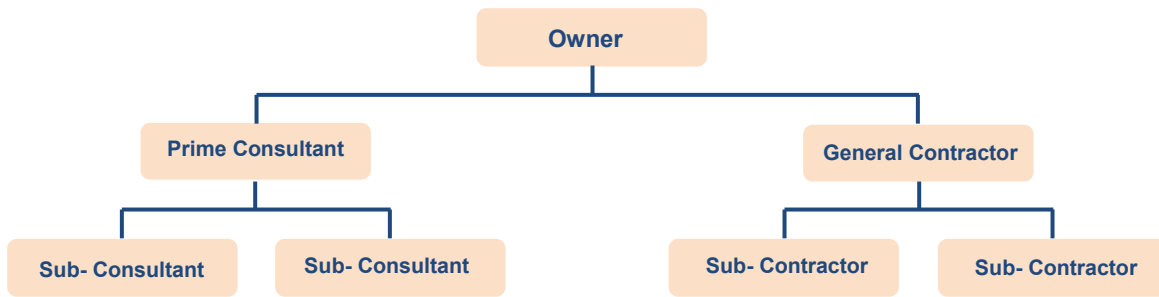

**Figure 2.8: Design-Bid-Build (DBB) Contractual Arrangements**

The owner reduces its risk by having a single point of contact with respect to the project design and project construction. The architect is responsible to the owner for the design, and the contractor is accountable to the owner for the construction means and methods. This independent relationship between the architect and the contractor allows the architect to monitor the quality of work properly and advise the owner and the contractor of any deficiencies that need to be rectified. Furthermore, owners, consultants, and contractors are familiar with their contractual roles and responsibilities in the DBB arrangement. Most of the public owners developed standard contracts to simplify and standardize the process. In addition, the completion of the design in advance of the bidding process allows the owner full control over the design and provides contractors sufficient information to submit competitive bids and commit to a fixed price. This provides the owner with preliminary competitive and reliable cost information before construction starts which helps the owner to plan the project finance (Mahdi and Alreshaid, 2005; Culp, 2011; Becker and Murphy, 2008; CMAA, 2012).

Despite the popularity, long history, and extensive use, the disadvantages of the DBB have been widely recognized in the literature and the industry. The DBB doesn't allow fast-tracking construction due to the separation of design and construction phases. This sequential process slows down the project progress since the design, drawings and specifications must be complete, and the whole project is tendered and awarded before the start of construction. The DBB procurement process usually dictates awarding the contract to the lowest bidders. As a result, the contractor may use different materials and employ unqualified trades to complete

the project and the owner may not receive the expected quality, and accordingly, additional quality control measures are required. Besides, the owners usually have limited input in the retention of the sub-contractors as the general contractor selects them during the tender phase; thus, sub-contractors with less qualifications than required are sometimes retained. Furthermore, the absence of constructability feedback during the design phase limits the ability of A/E team to assess scheduling and cost consequences of important design decisions regarding the selection of the most feasible and constructible systems, materials and equipment. As such, the DBB exposes owners to an excessive number of change orders and claims by contractors over design-coordination and constructability because the owner assumes responsibilities of the design in DBB delivery method. This, in turn, creates adversarial relationships between the contractor, the consultant, and the owner (Hegazy, 2002; Mahdi and Alreshaid, 2005; Rajos and Kell, 2008; Ghavamifar, 2009; Rosner et al., 2009; Culp, 2011; CMAA, 2012; Tran and Molenaar, 2015; Carpenter and Bausman 2016).

### **2.5.2 Design – Build (DB) Delivery System**

Design-Build (DB) is the fastest growing and also the oldest project delivery method where a master builder was responsible for the design and construction. The DB was the dominant project delivery method until the late 19<sup>th</sup> century when the design and construction teams were separated due to the advance in technology and the increasing sophistication of buildings. DB is also known as Engineer-Procure-Construct (EPC) in industrial construction. Under the DB methodology, the owner selects one entity to carry out the design and construction as shown in Figure 2.9. The owner prepares a Statement of Requirement that includes the project scope, programming, and performance criteria. The owner team typically completes between 5–30% of the project preliminary design and then uses performance-based specifications to solicit competitive bids. The owner posts a Request For Qualifications (RFQ) to short-list qualified DB firms. Subsequently, the owner develops a detailed Request For Proposals (RFP) that includes the Statement of Requirement and provides detailed instructions to the short-listed DB firms to develop their final proposals. The selection process of the DB is complicated and costly as it requires a clear definition of the performance requirements, and comprehensive

evaluation criteria to minimize future problems. The process also needs the owner’s team to have the necessary expertise and deep understanding of the design-build process. At the end of the project development stage, a fixed-price contract is awarded to the successful proponent (Konchar and Sanvido, 1998; Ibbs et al., 2003; Mahdi and Alreshaid, 2005; Hale et al., 2009; Rosner et al., 2009; Culp, 2011; Friedlander, 2011; BCCA, 2012; Shrestha et al., 2012).

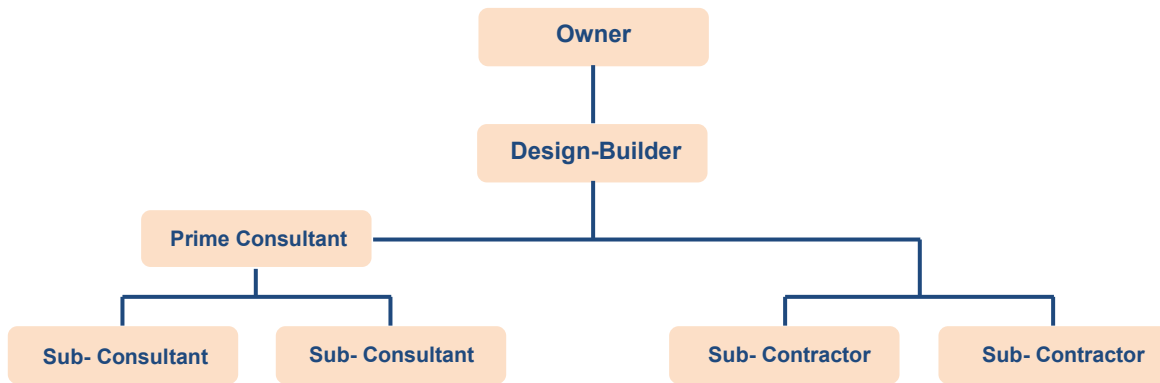

**Figure 2.9 Design-Build (DB) Contractual Arrangement**

The use of DB has significantly grown in popularity the last two decades. The major advantage of the DB is the speed of delivery. The integration of design and construction companies provides greater opportunities for cooperation between the consultant and the contractor during the design phase. In addition, the DB facilitates fast-tracking as the contractor can start construction once portions (packages) of the design are complete, which provides the ability to deliver projects with a tight schedule in a timely fashion. Moreover, utilizing conceptual estimating techniques allows the owner and the Design-Builders to agree on a fixed price at the beginning of the project, which enables the owner to accurately budget and finance the project. The DB fosters collaborative and more productive means of communication, which reduces the conflicts between the architect and the contractor and minimizes the owner involvement in design-construction disputes. The DB provides the owner with one source of accountability and transfers design, schedule, budget, and performance risks to a single entity. (Hegazy, 2002; Williams 2003; Mahdi and Alreshaid, 2005; Becker and Murphy, 2008; Mafakheri et al., 2007; Clup, 2011; Friedlander, 2011; CMAA, 2012; Gofar et al., 2014).

Despite the growing popularity, the DB demonstrates several disadvantages, particularly to public owner organizations. Since the architect and the builder form one entity, the architect no longer assumes the role of the “policeman” for the owner on the project. This lack of checks and balances may affect the quality of the project. Another major disadvantage of DB is the limited owner control over the project design. The owner can only review the design to ensure compliance with the preliminary performance-based specifications that had been established during the bidding process. Moreover, the ease and the casual means of communication among the Design-Builder team may keep the owner out of the communication loop and limiting the owner involvement. Consequently, the DB team makes decisions during the design and construction that may impact the project quality without the owner’s knowledge (Hegazy, 2002; Alkhalil, 2002; Friedlander, 2011; CMAA, 2012; Jazayeri and Pajouhi, 2017).

### **2.5.3 Construction Management (CM) Delivery System**

Construction Management (CM) delivery system is two broad approaches. At one end is Construction Manager Agent (CMA) where the owner hires a project manager as its agent for managing the construction project and is sometimes called Construction Management/Project Management (CM/PM). The CM mainly provides advisory services to the owner regarding the project scope, schedule, budget and procurement. The CM’s risk is limited as the CM does not contract with sub-contractors, does not perform actual construction, and is not responsible for the construction cost or meeting the project deadline. As a result, this delivery method is commonly known as Construction Manager “Not-at-Risk”. It is argued by some researchers and industry experts that CMA is not an actual project delivery method and it is only a form of consulting services to owner organizations. At the other end is Construction Manager at Risk (CMR) where the CM contracts with the subcontractors and is responsible for the construction cost and meeting the project deadline, similar to the GC role in DBB (Alberta Infrastructure, 2001; Mahdi and Alreshaid, 2005; Becker and Murphy, 2008; Ghavamifar, 2009; Minchin, 2009; Friedlander, 2011).

**Construction Manager at Risk (CMR)** is considered the most important type of construction management delivery systems that provides a comprehensive approach to complete construction projects and minimizes the owner risk exposure. Under CMR, the owner selects an Architect/Engineer to prepare the design and separately retains a CM to construct the project. Both are selected based on their qualifications to provide quality design and construction services, and competitive fees. The design and construction teams are contractually independent and are responsible to the owner, as shown in Figure 2.10. This separation provides the owner with full control over the project design, budget, and schedule. During the design phase, the CM provides real-time data input with respect to the most feasible and constructible materials and equipment, realistic schedule, and conducts value engineering when needed to maintain the project budget. Once the design is close to completion, the CM often agrees with the owner on Guaranteed Maximum Price (GMP) for the project. The GMP usually consists of the cost of the work performed by the CM own-forces, and the cost of work performed by sub-contractors hired by the CM. During construction, the roles and responsibilities of the CM are expanded, and the CM operates as a GC in DBB. Thus, in some literature, the CMR is referred to as Construction Manager/General Contractor (CM/GC). This delivery method enables the owner to minimize its risk exposure by contracting only with the CM, and benefits from having a single point of contact. Most of the construction risks are transferred to the CM who is responsible for the work performed by own forces and by other sub-contractors to achieve the project goals, to meet the project deadline, and to complete the project within established GMP. (Williams, 2003; Minchin, 2009; CMAA, 2012; Mahdi and Alreshaid, 2015; Carpenter and Bausman 2016; Farnsworth et al., 2016).

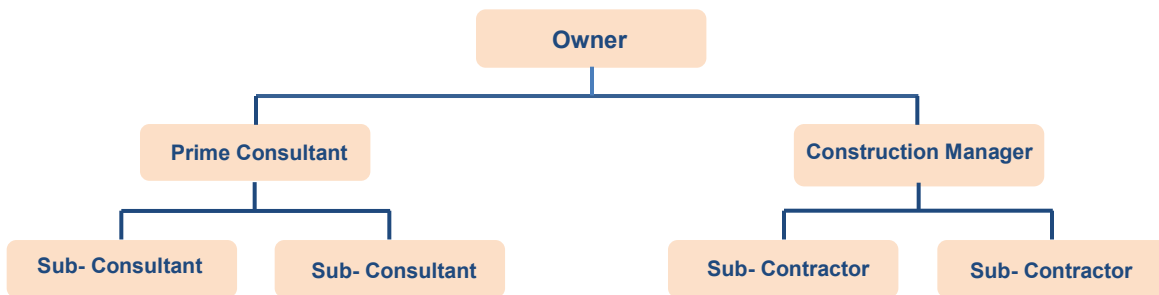

**Figure 2.10: Construction Manager at Risk (CMR) Contractual Arrangements**

The CM is usually selected for its expertise and qualification in managing construction projects and is engaged early in the design phase. This early involvement allows the CM to assist the owner and the consultant in avoiding design constructability issues and delivering the most feasible and constructible design. An important advantage of CMR is the ability to expedite projects with challenging deadlines. Once the design of early activities such as shoring and foundations, is complete, these packages can be tendered, and construction starts while the remaining of the design is being developed. This overlapping of design and construction is commonly known as fast-tracking, which is an advantageous feature that enables CMR and DB systems to deliver projects with a tight schedule in a timely fashion. The owner maintains full control over the design and the budget by having the CM updating the project budget as the design progresses. Furthermore, the project team has control over the project schedule and can properly plan activities and sub-contractors to meet the project deadline. The CMR arrangement reduces the owner's exposure to contractual risk as the CM hires and manages the suppliers and sub-contractors and is responsible for their performance. Moreover, unlike DBB, the CMR arrangement promotes collaboration and reduces disputes between the project parties (Williams, 2003; Becker and Murphy, 2008; Rajos and Kell, 2008; Minchin, 2009; CMAA, 2012; Carpenter and Bausman 2016; Farnsworth et al., 2016).

Despite the above advantages and its ability to address several drawbacks of DBB and DB, the CMR demonstrates serious disadvantages. CMR approach does not provide the owner with cost certainty until all the sub-contractors' packages are tendered and awarded (or a GMP is established). Another major disadvantage of the CMR perceived by owner organizations is the lack of competitive bidding process as the CM usually self-perform portions of the work, and parts of the project total cost (GMP in many cases) are not subject to competitive bidding process. As such, owners might not obtain the most competitive market value for their projects and utilizing CMR would likely cost more than utilizing the traditional DBB (Konchar and Sanvido, 1998; Alberta Infrastructure, 2001; Williams, 2003; Rajos and Kell, 2008; Carpenter and Bausman 2016; Farnsworth et al., 2016).

#### **2.5.4 Research Efforts on Project Delivery Methods**

Significant efforts in the literature were dedicated to providing statistical analysis to compare the performance of the most common project delivery methods (i.e., DBB, DB, and CMR) using the following metrics:

1. Cost Growth which is the percentage of the final cost overrun compared to the initial estimate or contract price;
2. Schedule Growth which is the percentage of the schedule delay compared to the intended schedule;
3. Delivery Speed;
4. Unit Cost; and
5. Quality that measures client satisfaction.

Sullivan et al. (2017) provided an extensive summary of the research efforts that compared the performance of the three main project delivery methods using the above-mentioned project performance metrics, as outlined in Table 2.1. They presented an interesting discussion about different approaches that were followed in the literature to assess the cost and schedule growth of various project delivery methods. Some researchers compared the final cost of a project to the awarded amount which is the initial contract value while other researchers compared the final cost to estimates made earlier than the contract award date. Many studies did not specify the time or the method with which the estimated cost and duration were developed. This is a serious concern that needs to be addressed in future analysis as the cost and duration are estimated many times during the project's lifecycle. In addition, they recommended extra care to be taken to ensure that projects are closely comparable when measuring performance based on a unit cost and delivery speed. They concluded that there are potential areas of improvement in standardizing the analysis of performance metrics to improve the understanding of the performance difference between delivery methods.



**Table 2-1: Research Efforts for Analysis of Project Performance Metrics (Adapted from Sullivan et al. 2017)**

Existing study	DB cost growth	CMR cost growth	DBB cost growth	DB unit cost	CMR unit cost	DBB unit cost	DB schedule growth	CMR schedule growth	DBB schedule growth	DB delivery speed	CMR delivery speed	DBB delivery speed	DB quality	CMR quality	DBB quality
Allen(2001)-horizontal	x	-	X	-	-	-	x	-	x	-	-	-	-	-	-
Allen (2001)- vertical	x	-	X	x	-	x	x	-	x	-	-	-	x	-	x
Bennett et al. (1996)	-	-	-	x	-	x	-	-	x	-	-	x	-	-	-
Debellaand Ries (2006)	x	-	-	x	-	-	x	-	-	x	-	-	x	-	-
El Wardani et al.(2006)	x	-	-	x	-	-	x	-	-	x	-	-	x	-	-
Ellis et al (1991)	x	-	X	-	-	-	x	-	-	-	-	-	-	-	-
Gransberg et al. (2000)	x	-	X	-	-	-	x	-	x	-	-	-	-	-	-
Hale et al. (2009)	x	-	X	x	-	x	x	-	x	x	-	x	-	-	-
Hwang et al. (2011)	x	-	X	-	-	-	x	-	x	-	-	-	-	-	-
Ibbs et al. (2003)	x	-	X	-	-	-	x	-	x	-	-	-	-	-	-
Jeelani et al. (2012)	x	-	-	-	-	-	x	-	-	-	-	-	x	-	-
Konchar and Sanvido(1998)	x	x	X	x	x	x	x	x	x	x	x	x	x	x	x
Kulkami et al. (2012)	-	x	-	-	-	-	-	-	-	-	-	-	-	-	-
Migliaccio et al. (2010)	x	-	-	-	-	-	-	-	-	x	-	-	-	-	-
Minchin et al. (2013)	x	-	X	-	-	-	x	-	x	-	-	-	-	-	-
Molenaar et al. (1999)	x	--	-	-	-	-	x	-	-	-	-	-	x	-	-
Neidert (2012)	-	x	-	-	-	-	-	-	-	-	-	-	-	-	-
Pocock et al. (1996)	x	-	X	-	-	-	x	-	x	-	-	-	x	-	x
Reinisch (2011)	x	x	X	x	x	x	-	-	-	-	-	-	-	-	-
Rojas and Kell (2008)	-	x	X	-	-	-	-	-	-	-	-	-	-	-	-
Rosner et al. (2009)	x	-	X	x	-	x	x	-	x	-	-	-	x	-	x
Roth (1995)	x	-	X	x	-	x	-	-	-	x	-	x	-	-	-
Sanvido and Konchar(1997)	x	x	X	x	x	x	x	x	x	x	x	x	x	x	x
Shrestha et al. (2007)	x	-	X	x	-	x	x	-	x	x	-	x	x	-	x
Shrestha et al. (2012)	x	-	X	x	-	x	x	-	x	x	-	x	-	-	-
Thomas et al. (2002)	x	-	X	-	-	-	x	-	x	-	-	-	-	-	-
Touran et al. (2011)	x	x	X	-	-	-	x	x	x	-	-	-	-	-	-
Uhlik and Eller (1999)	-	-	X	-	-	-	-	-	x	-	-	-	-	-	-
U.S. DOT (2006)	x	-	X	-	-	-	x	-	x	-	-	-	x	-	-
Warne (2005)	x	-	-	-	-	-	-	-	-	-	-	-	x	-	-
Williams (2003)	-	x	X	-	-	-	-	x	x	-	-	-	-	-	-

Other efforts in the literature focused on studying generic factors affecting the selection of suitable project delivery methods. Alkhalil (2002) used Analytical Hierarchy Process (AHP) to select the proper project delivery method considering several influential factors that affect this selection such as schedule, scope, cost, and owner's needs. AHP technique was also used by Mahdi and Alreshaid (2005) to develop a Decision Support System to select the suitable project delivery method considering similar factors. Lie et al. (2016) used a more detailed list of possible factors that affect the PDM selection such as complexity of the project and the confidentiality protection. Mafakheri et al. (2007) used AHP under uncertainty to select the proper PDM. Oyetunji and Anderson (2006) utilized Simple Multi-tribute Rating Technique with Swing Weights (SMART) to provide a quantitative method to determine the most suitable PDM. Chen et al. (2011) used Artificial Neural Network (ANN) technique to develop project delivery selection model considering 16 generic project and owner indicators.

The above efforts provide useful tools to guide the project delivery method selection process. However, the understanding of the unique characteristics of the infrastructure rehabilitation scattered repetitive projects at municipalities, school boards, and universities, and their role in selecting the proper PDM is not adequately developed. Moreover, efforts in the literature do not suggest adjustments to the currently established project delivery methods to suit the nature of a specific type of projects. This study discusses in detail, the unique characteristics of the infrastructure rehabilitation scattered repetitive projects at school boards and universities that should guide the selection of the suitable PDM. Furthermore, the study suggests modifications to current project delivery methods to suit the specific challenges of this type of projects, and address concerns found in the literature and expressed by public-sector administrators.

## **2.6 Summary and Research Gap**

Most of the existing scheduling and control techniques are CPM based, and experience serious drawbacks when applied to repetitive projects. The CPM based models do not guarantee work continuity which results in inefficient utilization of working crews; unable to present activities of different production rates; unable to recognize the location-based nature of repetitive

projects, and unable of accommodating multiple crews. In recognition of these disadvantages, various repetitive scheduling techniques (e.g., LOB, LSM, and VPM) were introduced and used mostly for linear repetitive projects. These methods, however, are useful in scheduling projects at the planning stage before construction starts, yet their project tracking and control feature during construction are less developed. Current project control techniques lack tools to incorporate all progress events directly on the schedule. As a result, the task of identifying corrective actions to alleviate any deviation from the original plans becomes a significant challenge. There is a need, therefore, for an effective project control technique that identifies cost and schedule deviations and proposes optimized corrective actions to ensure the project's objective are achieved. Thus, a mathematical schedule representation needs to be developed taking into account the special characteristics of scattered projects, along with the development of an optimization mechanism to produce schedules with least cost.

Several project delivery methods such as DBB, DB, and CMR are used to deliver different type of projects. Each method has its own advantages and disadvantages when applied to different types of projects. Therefore, the factors that guide the project delivery method for infrastructure rehabilitation scattered repetitive projects needs to be discussed. In addition, modifications to the current project delivery methods to improve their efficiency when applied to this type of projects is needed.

## **Chapter 3**

### **Field Study on Infrastructure Renewal Scattered Repetitive Projects**

#### **3.1 Introduction**

This chapter discusses the challenges that public-sector organizations such as municipalities, school boards, and universities are facing to renew their scattered facilities infrastructure that are heavily deteriorating due to age and the lack of sufficient funding for proper maintenance and rehabilitation. The unique characteristics of infrastructure renewal projects are investigated through a field study of the practical challenges encountered by two large public organizations (school board and a university) in delivering this type of projects. The identified challenges represent the specifications and the desired features for developing an efficient scheduling and control framework, and suitable project delivery method.

#### **3.2 Infrastructure Renewal Backlog at Public-Sector Organizations**

Municipalities across the country are faced with significant challenges to keep essential services and facilities operational because of the substantial rehabilitation backlog to renew their deteriorating infrastructure. The municipalities own a significant number of physical assets such as roads, expressways, bridges, traffic signal controls, water and wastewater treatment facilities, distribution and collection pipes, pumping stations, subways, civic centers, recreation facilities, public housing buildings, parklands, etc. (City of Toronto website). The infrastructure renewal backlog for municipalities is substantial and they are required to invest billions of dollars every year to address these infrastructure needs. The City of Toronto, for example, plans to spend \$31.7 billion in physical infrastructure projects between 2015 and 2024 and York Region plans to spend \$6.6 billion in the next 10 years (Siemiatycki, 2015).

Similarly, the infrastructure renewal challenges facing school boards throughout the country are significant. In Ontario, the infrastructure renewal cost is estimated to be as high as \$15-billion (Ontario Ministry of Education Report-2016). The Government of Ontario is investing hundreds of millions of dollars every year to help school boards improving their facilities condition (Figure 3.1).

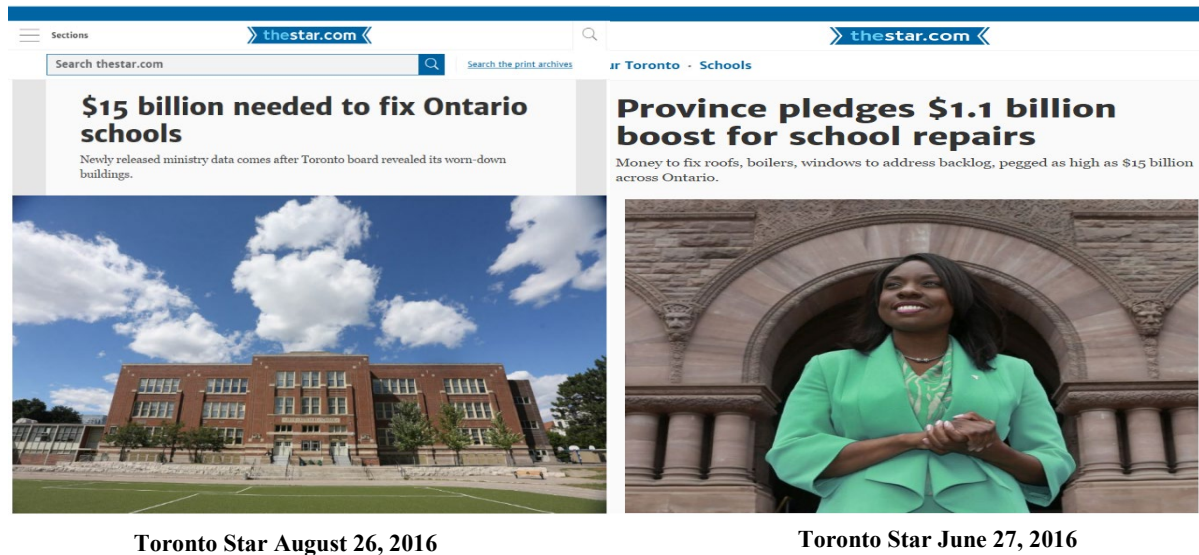

**Figure 3.1 Infrastructure Renewal Backlog at Ontario School Boards**

The facilities condition at Canadian universities is equally concerning. The Canadian Association of Universities Business Officers (CAUBO) estimated the total infrastructure renewal backlog cost for Canadian universities is \$8.4 billion in 2014. The Council of Ontario Universities (COU) issued an alarming report in 2014 outlines the facilities condition of Ontario’s universities, as shown in Table 3.1. The report estimates that universities in Ontario have about \$2.5-billion infrastructure renewal backlog and suggested funding scenarios to improve the condition of these facilities to an acceptable level. To achieve that, Ontario’s average annual expenditures on facility infrastructure renewal should be about \$624 million per year for the next 10 years. To help universities and colleges address their facilities and infrastructure needs, the Ministry of Training, Colleges, and Universities (MTCU) invested approximately \$340M in 2016 on capital and facility infrastructure renewal projects (MTCU website). This is in addition to the projects funded by the universities and colleges.

**Table 3-1: Infrastructure Renewal Backlog at Ontario Universities (COU Report 2014)**

University	Current Replacement Value (CRV)	Infrastructure Renewal Value
Brock	\$437,217,052	\$109,514,311
Carleton	\$784,525,517	\$160,520,106
Guelph	\$1,249,740,290	\$207,923,726
Lakehead	\$436,058,741	\$82,584,191
Laurentian	\$456,030,643	\$47,021,526
Algoma	\$28,518,480	\$4,315,731
McMaster	\$1,554,235,867	\$297,796,140
Nipissing	\$98,540,789	\$6,379,743
OCADU	\$84,134,760	\$2,027,355
UOIT	\$165,822,359	\$2,376,946
Ottawa	\$1,465,567,942	\$141,893,801
Queen's	\$1,387,237,415	\$186,805,993
Ryerson	\$1,081,750,760	\$71,598,194
Toronto: St. George Campus	\$2,945,001,765	\$474,945,511
Toronto: Scarborough Campus	\$325,499,673	\$42,638,004
Toronto: Mississauga Campus	\$453,576,829	\$38,822,600
Trent	\$289,543,050	\$36,370,632
Waterloo: Main Campus <sup>2</sup>	\$1,736,065,977	\$113,103,253
Waterloo: Affiliates	\$79,362,056	\$5,315,974
Western: Main Campus <sup>2</sup>	\$1,831,566,506	\$198,200,446
Western: Affiliates	\$88,563,830	\$5,173,804
WLU	\$406,479,934	\$43,341,494
Windsor	\$810,391,921	\$100,771,022
York: Keele Campus	\$1,737,848,307	\$118,813,862
York: Glendon Campus	\$104,434,635	\$12,911,259
<b>Total</b>	<b>\$20,037,715,100</b>	<b>\$2,511,165,624</b>

Significant efforts in the literature were dedicated to optimizing the allocation of the limited funding resources available for the renewal of deteriorated infrastructure (Hastak et al., 2005; Elbehairy et al., 2009; Orabi and El-Rayes, 2012; Rashedi and Hegazy, 2016). Limited efforts, however, addressed the implementation and the delivery phase of such projects. Most of the existing management systems at public-sector organizations provide limited decision support to the in-house management teams during the execution phase of infrastructure rehabilitation projects with regards to the execution planning and the project delivery methods (Figure 3.2).

This represents a major challenge that leads to cost overruns, schedule delays, and incomplete implementation of the infrastructure renewal programs (Kamarah and Hegazy 2017). Having an effective scheduling and control system, along with proper project delivery method would improve the chances of completing projects successfully and would result in significant economic and social impacts through more efficient utilization of the limited funds and maximizing the benefits of the invested public capital.

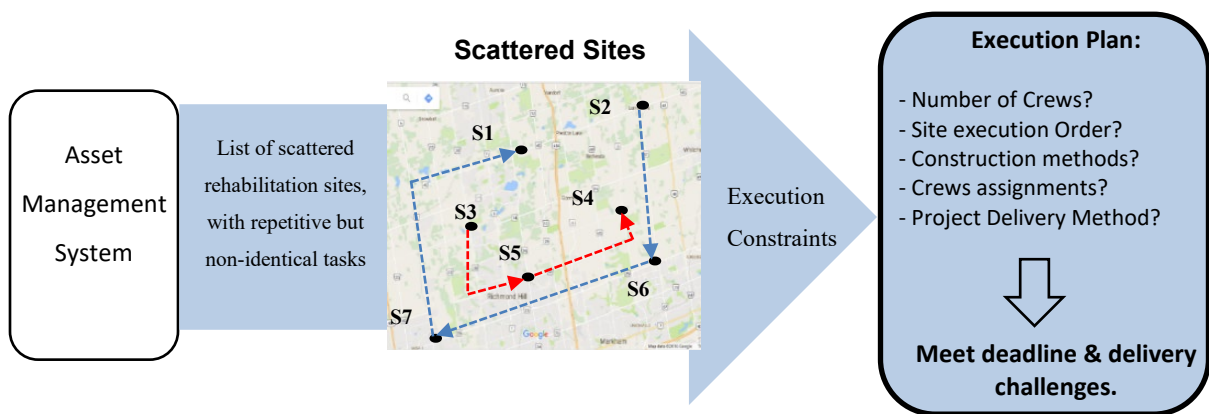

**Figure 3.2 Execution Planning for Scattered Repetitive Projects**

### 3.3 Field Study

Before designing the proposed scheduling and control framework, and recommending suitable project delivery method, it was important to investigate current industry practices to identify practical considerations and requirements in an effective project scheduling and control tool, and the suitable project delivery method. As such, current practices for implementing scattered repetitive infrastructure renewal projects were investigated at McMaster University (referred to as The University) and the Toronto District School Board (referred to as The School Board) as representative samples of school boards and universities across the country.

### 3.3.1 The University

The University is one of the largest universities in Canada with about 30,000 full-time students. The enrollment has increased from 20,056 students at 2002/2003 to 29,411 students at 2012/2013 and the number is growing every year. The campus comprised of 56 buildings, in addition to several off-campus buildings. The Current Replacement Value (CRV) of these facilities is estimated at approximately \$1.6 billion in 2014, and the numbers are growing as new buildings are added to the campus almost every year.

Like other universities and school boards across the country, the University is challenged with significant infrastructure renewal backlog as more than 65% of its buildings are older than 40 years. Many of the electrical and mechanical systems, building envelop systems, and interior finishes have exceeded their life expectancy. In addition, the campus central heating and cooling plant and the main campus electrical transformers are long overdue for replacement. Facility Services team at the University has estimated its infrastructure renewal backlog at \$290 million in 2013 (Figure 3.3) and is projected to be \$460 million in 2022.



Figure 3.3: Infrastructure Renewal Backlog at the University (CBC February 6, 2013)



The University utilizes a provincial-wide approved asset management system VFA to monitor the condition of its facilities. The system categorizes each deficient building system into priorities, ranging from 1 to 5, as illustrated in Table 3.2.

**Table 3-2 VFA Condition Assessment Recommendation (COU Report, 2014)**

<b>Priority</b>	<b>Description</b>	<b>Timeframe to Complete</b>
1	Critical	Immediate within a year
2	Potential Critical	One to three years
3	Necessary but not yet critical	Three to five years
4	Recommended	Meet the basic function of facility but would improve overall usability
5	Does not meet the current code or standard	Does not conform to current code

To improve the current facilities condition and prevent further deterioration, the University needs to spend about \$16million every year for the next 10 years on infrastructure renewal projects (The University-Asset Management Plan - 2012). In 2015, the university completed about 50 projects and invested approximately \$14 million on its infrastructure renewal program and interior renovation projects that include:

- Replacing leaking roofing for various buildings;
- Replacing single pane windows with efficient double panes for various buildings;
- Repairing the cladding and the waterproofing for various buildings;
- Upgrading mechanical systems and replacement of mechanical equipment such as air handling units, exhaust fans, pumps, hot water tanks, chilled and hot water piping, etc.;
- Upgrading electrical systems and replacement of electrical equipment such as transformers, fire alarm systems, electrical panels, high voltage cables, and lighting;
- Improving campus accessibility by building ramps, installing automatic doors, upgrading elevators, and modifying washrooms;
- Replacing the existing deteriorated asphalt sidewalks with accessible concrete sidewalks, and repaving parking lots; and

- Interior renovation projects that include upgrading current labs or converting other spaces to labs, upgrading classrooms, administrative offices, hospitality facilities, etc. This also includes painting, flooring and ceiling replacements.

### 3.3.2 The School Board

The School Board is one of the largest school boards in the country, with hundreds of schools that span across a major metropolitan area (Figure 3.4).

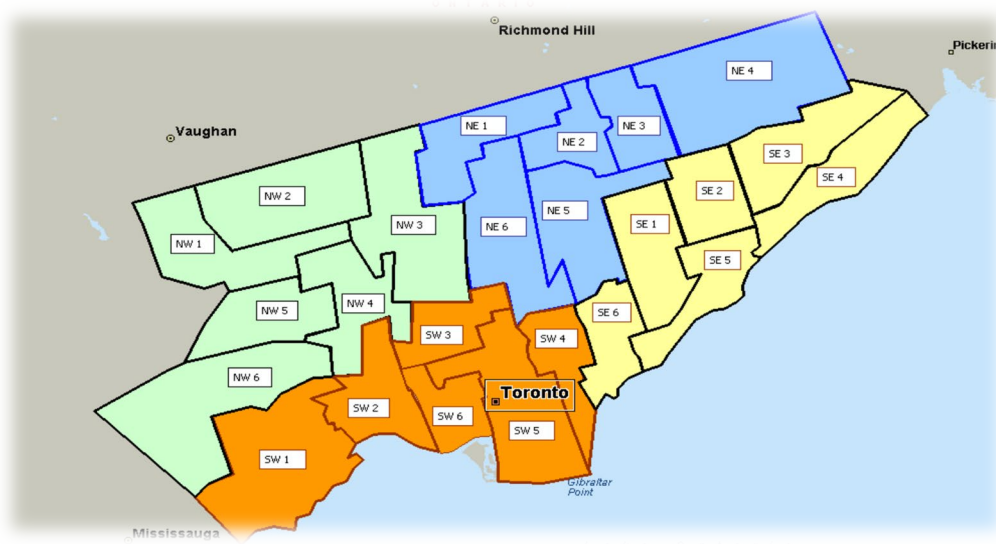

**Figure 3.4: The School Board Map (Ahluwalia, 2008)**

Like other school boards, the School Board suffers from a serious backlog of infrastructure renewal needs as more than 75% of the schools are 50 years or older, which imposes a significant challenge to bring their condition to an acceptable level. To manage this large number of facilities, the School Board utilizes an asset management software that classifies buildings' components to four levels, Critical, Poor, Fair, and Good (Ahluwalia, 2008; Issa et al., 2010). The estimated Current Replacement Value (CRV) of the School Board is estimated

in several billions of dollars. Currently, the School Board has multi-billion dollars infrastructure renewal backlog (Figure 3.5). Renewal work includes the replacement of critical building components such as boilers, chillers, pumps, air handling units, plumbing, electrical systems, building envelopes (i.e., windows, roofing, and cladding), and interior finishes.

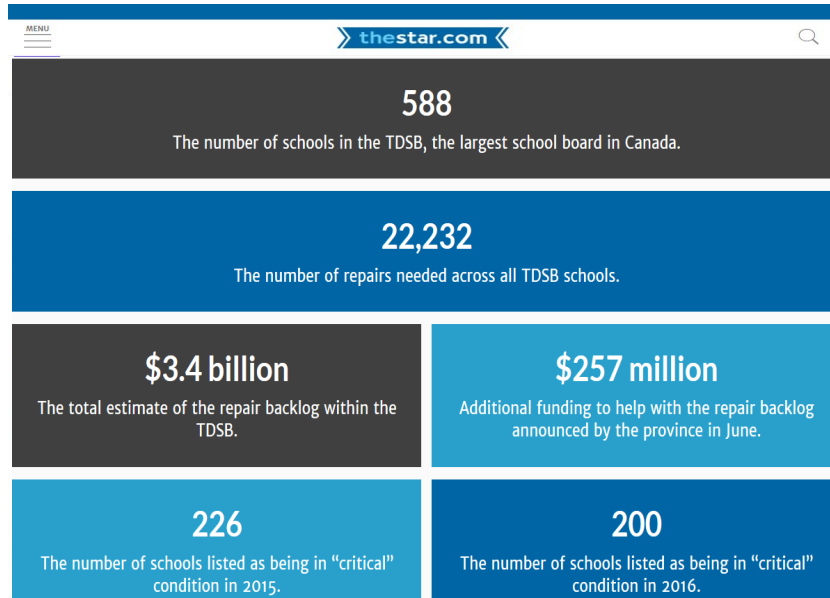

**Figure 3.5 : Infrastructure Renewal Backlog (Toronto Star August 22, 2016)**

The School Board invested more than \$92 million on approximately 340 infrastructure renewal projects in 2015/2016 (Table 3.3). These projects include replacements of mechanical and electrical systems, roofing replacement, windows replacement, cladding repairs, interior renovations, etc. The funding by the Province of Ontario for the School Board infrastructure renewal has increased substantially in the last three years to address the serious infrastructure renewal backlog.

**Table 3-3: Infrastructure Renewal Projects in 2015/2016 and Renewal Backlog in 2016**

Project Classification	Number of Projects	Approximate Contract Values	Renewal Backlog
Roofing	104	\$20,825,066	\$186,473,793
Mechanical	56	\$13,595,822	\$1,254,289,040
Structural/Brick Work	23	\$21,577,976	\$184,578,337
Windows	9	\$3,084,100	\$94,692,929
Electrical	32	\$4,801,839	\$569,500,021
Barrier Free	7	\$1,141,312	\$-
Parking Lots	9	\$1,517,250	\$79,234,465
Field Restoration	23	\$9,866,543	\$302,358,338
Interior Components/Fascia/Painting	16	\$2,210,833	\$825,104,680
Other work	61	\$13,795,564	\$8,683,048
<b>Total</b>	<b>340</b>	<b>\$92,416,305</b>	<b>\$3,504,914,561</b>

### 3.4 Practical Challenges in Delivering Scattered Repetitive Projects

Once the list of the infrastructure renewal projects is established for a specific year, and the required funding is allocated, the delivery team starts planning for the execution phase of the project. The delivery teams are usually encountered with significant challenges that affect their ability to complete this type of projects in a timely and cost-effective manner, as shown in Figure 3.6. The following sub-sections describe some of the challenges faced by the project management teams at The University and The School Board during the implementation of their infrastructure renewal projects. In addition, the requirements in effective scheduling and control techniques, along with a suitable project delivery method to enable effective delivery of the annual rehabilitation programs are discussed.

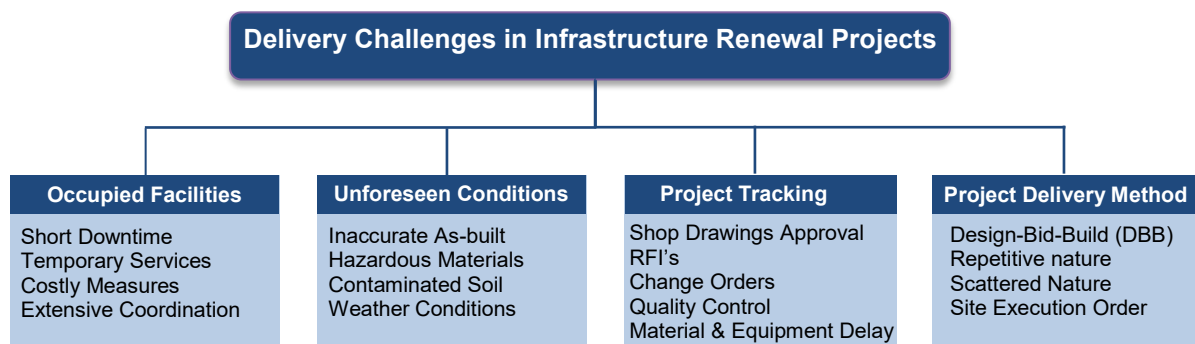

**Figure 3.6: Practical Challenges for Infrastructure Renewal Projects**

### **3.4.1 Service Interruption to Occupied Facilities**

A challenging constraint for infrastructure renewal projects execution plans is to minimize service interruption to facilities occupants and meet stringent operational requirements. At the School Board, a significant number of infrastructure renewal projects such as the replacement of roofing, windows, mechanical and electrical systems are executed during the summer break when classes are not in session to reduce the impact of the construction activities on schools' operation. To meet challenging deadlines, expensive acceleration measures, such as working after hours or weekends, are often implemented. During the academic year, construction activities usually take place after school hours. Working after school hours (from 4pm to midnight) significantly reduces crews' productivity. In addition, some union's collective agreements include paying a premium for working at night. The reduced productivity combined with premium rates imposes pressure on the project budget and schedule.

The University is a research-intensive university and is known for its medical and health science research institutions, and as a result, several research facilities are operational around the year. To maintain labs functional and minimize interruption, several logistics, and health and safety challenges are encountered. The project management team often alters construction schedules and sequence of activities to accommodate operational requirements. For example, in a windows replacement project, the construction team coordinates the work with the occupants of each room and schedule the work at suitable times for them. Accordingly, the productivity is decreased, and the construction cost and duration are increased. Often, temporary heating or cooling services are provided to keep facilities operational while the project is executed. Effective scheduling and control tools should consider these practical challenges and their impact on the project schedule and budget. Thus, enable the project team to establish a realistic and accurate baseline plans and avoid unplanned interruptions to working crews.

### **3.4.2 Unforeseen Conditions**

In many occasions, the project management teams are encountered with unforeseen conditions that alter the construction sequence and negatively impact the project schedule and cost.

A primary source of unforeseen conditions is the fact that infrastructure renewal projects take place in old facilities where as-built drawings are not reliable and do not accurately reflect the actual condition of existing building components. Besides, project teams are usually unable to conduct a thorough investigation during the design phase to avoid interrupting the facility operation. Therefore, the combination of insufficient site investigation and the lack of accurate as-built drawings often result in drawings that expose the project management teams to lengthy and expensive change orders as described later in this chapter.

For example, in many occasions, when boilers or air-handling units are removed, the construction team discovers that existing pipes and ducts are corroded or leaking and need to be replaced which requires a change order to be issued to the contractor. Furthermore, the increasingly stringent environmental regulations impose schedule and budget challenges to infrastructure renewal projects. Most of the School Board and the University facilities were built under different environmental regulations. Several materials that were used in their construction are now considered hazardous such as asbestos, lead, etc. These materials must be removed safely and disposed as hazardous materials before proceeding with subsequent construction activities.

Similarly, replacing underground infrastructure such as high voltage cables, water mains, and sewer networks require soil excavation and backfilling. Often, contaminated soils are encountered which triggers lengthy and costly testing and disposal process. In addition, unfavorable weather conditions greatly impact the work on construction projects. Exterior activities are the most affected by weather such as excavation, concrete, asphalt work, roofing, and windows. The interior work activities are also affected by poor weather condition because finishing activities cannot start until the building is watertight (i.e., roofing and windows are installed). Addressing these unforeseen conditions imposes scheduling and budgeting challenges to most infrastructure renewal projects and would usually cause schedule delay and cost overrun if not appropriately managed.

### **3.4.3 Project Progress Tracking**

A serious challenge facing the project management teams at the University and the School Board is to track the progress of a large number of projects at numerous scattered sites to enable accurate performance analysis, to predict potential problems, and to identify effective corrective actions when actual progress deviates from the original plans. Infrastructure renewal projects consist of a large number of activities that are performed by a large number of parties (architects, engineers, inspectors, sub-contractors, general contractors, owner personnel). This type of projects generates a massive volume of information (specifications, drawings, tender documents, shop drawings, cost data, schedule data, progress draws, requests for information (RFI), change notices (CN), change orders (CO), inspection reports, progress reports, etc.).

Construction projects are dynamic by nature, and the timely flow of information between parties is critical to the project success as it strongly impacts the project performance. Often the project team discovers that a contractor did not order a piece of equipment because the engineer did not approve the shop drawings on time. An RFI that was not answered on time or it was answered without clear instructions to the contractor to follow. A CO that is waiting for the contractor to price, for the consultant to review, or for the owner to approve. These are daily events at every construction project, and it is critical that the following activities must be tracked closely to ensure the project is progressing satisfactorily.

**Shop Drawings Approvals:** Shop drawings are produced by suppliers and subcontractors to describe how the design is intended to be implemented by the contractors and include more details than the “Issued For Construction” drawings. Examples of equipment and components that require shop drawings are rebars, structural steel, pre-cast, roofing, windows, boilers, chillers, air-handling units, transformers, generators, building control systems, light fixtures, elevators, doors, millwork, etc. The consulting team must review and approve before the contractor proceeds with production to ensure conformance with the design documents. The consultant team reviews and stamps shop drawings with one of three comments: a) approved as submitted; b) approved as noted; or c) revise and re-submit which delays the fabrication and

delivery of these systems. Shop drawings for complicated mechanical, electrical, and building envelop systems take a long time to produce and may require site measurement verifications. It is essential for the project team to track shop drawings submittals and approvals to ensure timely delivery of the equipment, particularly the long lead items such as boilers, chillers, air handling units, transformers, lighting fixtures, etc.

**Material and Equipment Delivery:** This is a well-recognized cause of delays and may result from a variety of reasons. A delay in producing the shop drawings by the contractors, and/or longer review time by the consulting team than planned. As modern buildings have become more technologically advanced, the required materials, systems, and equipment are not standardized and tend to be customized. For example, it takes approximately 16-20 weeks to deliver air-handling units and boilers from the time the shop drawings are approved. Similarly, it takes almost 12-16 weeks to deliver glazing from the time the site measurements are verified. Some equipment may be ordered from overseas which takes long time to transport and clear customs. Some materials and equipment are delivered with wrong specifications and must be re-ordered. These delays compromise the ability of the construction team to maintain work continuity and imposes serious challenge in meeting deadlines.

**Request For Information (RFI):** RFI is a tool used by contractors to clarify gaps, conflicts, and ambiguities in the drawings and specifications during construction. The RFI is issued to the consulting team to provide answers and the response time is a potential cause of schedule delays. Often, the response to the RFI includes modifications to the drawings and specifications and leads to costly and disruptive change orders.

**Change Orders (COs):** They are considered the primary reason for construction delays, cost overruns, and disputes. A change order is required when there is a change to the original scope of work as identified in the base contract documents. It can be either an addition to the base (original) contract or deletion from the base (original) contract. When the project base cost or duration are affected, a change order is executed to either increase/decrease the cost,



and/or to extend /shorten the duration. Change orders are becoming a feature of modern construction projects, particularly large and complicated projects. Change orders can be introduced by the owner or requested by the contractor, and usually result from the following reasons:

- 1) *Design Modification*: addresses revisions to the base contract drawings and specifications and are usually introduced by the owner.
- 2) *Design Errors and Omissions*: addresses items that are missing or not correctly defined in the base contract drawings and specifications.
- 3) *Site Conditions*: addresses unforeseen actual site conditions that are different from the conditions identified in the base contract drawings and specifications.

Identifying, describing, pricing, negotiating, and approving change orders is the primary cause of project delay and cost overrun particularly change orders that result from unforeseen site conditions. This is widely documented in the literature and recognized by project management teams (Riley et al., 2005; Senouci et al., 2016; Bolin, 2018).

**Quality Control Process:** Owners usually retain a testing and inspection agent to ensure the work is properly executed. Besides, consultants and architects visit the site periodically to ensure the construction is progressing in compliance with the contract documents. Sometimes, the inspecting agents or the consultants observe incompliance with the contract documents and issue a notice to comply and correct the deficiencies. In some instances, the work needs to be re-done which causes delays and additional cost incurred by the contractor and subcontractors.

For scheduling, and control tool to be effective, it must account for the impact of RFI response time, shop drawings approval time, equipment delivery time, and change orders in the project schedule and budget. It must be able to record these events to identify responsible parties and determine corrective actions to bring the project back on track when deviates from the original plan. Moreover, the proper project delivery method should provide the project team with adequate flexibility to consider and react to these challenges and effectively allocate resources to accommodate the logistics constraints in a timely and cost-efficient manner.

### **3.4.4 Project Delivery Methods**

A key challenge to a successful implementation of infrastructure renewal programs is the delivery method by which public-sector organizations deliver this type of projects (This is discussed in detail in Chapter 6). Typically, large public organizations utilize in-house forces to perform a small portion of their work, which is beneficial in responding to emergencies that must be done immediately without enough time to develop a proper scope of work. Most of the work is outsourced which allows the owner to obtain competitive market values for their projects and pass construction risks to contractors. However, with infrastructure rehabilitation being a case of multiple small projects, considering each project separately involves a large amount of administrative efforts to plan, supervise, monitor, and control this large number of projects. Each project at each site is implemented separately which requires separate consultant and contractor in addition to the owner representatives.

Like most public-sector organizations, the School Board and the University utilize the traditional DBB which dictates awarding the contracts to the lowest bidders to comply with various municipal, provincial, and federal procurement policies. The disadvantages of the DBB are widely documented in the literature (discussed in chapter 2) and recognized by public-sector administrators. Furthermore, procuring each project at each site separately denies public-sector organizations from realizing the benefits of the economy of scale in procuring services, materials, and equipment necessary to complete these projects.

Managing multiple infrastructure renewal projects at various scattered sites is a complicated and challenging task. Infrastructure renewal projects are repetitive and considering each site as a separate project with separate general contractor and sub-contractors deprives public-sector organizations the opportunity to benefit from repetition if the work continuity is maintained and the crews are effectively synchronized. On the other hand, these projects are scattered across distributed sites (schools and other buildings) over a large geographical area. Thus, the site execution order must be properly planned to ensure each activity at each site is scheduled when it has the highest possible productivity as the local conditions, such as intensity

of use, unforeseen conditions, union jurisdictions, by-laws, traffic congestion, etc., may vary from one site to another (Kamarah and Hegazy, 2017).

Therefore, an efficient execution plan and project delivery method should benefit from the repetitive nature of this type of projects. It should also mitigate the impact of being scattered over large geographical areas, consider the local conditions, and the time and cost of moving crews (labor, materials, and equipment) from one site to another. This could be particularly important for infrastructure renewal projects at school boards because their hundreds of buildings scattered throughout large geographical areas and any change in site execution order may impact the project duration and cost.

### **3.5 Existing Management Systems**

Many municipalities, school boards, and universities utilize management systems that are usually part of larger Enterprise Resource Planning Systems (ERP) such as SAP and PeopleSoft. These systems are mainly capable of managing maintenance work orders, tracking in-house resources, processing progress draws and change orders, and monitoring the projects cash flow. Some of these systems have useful basic scheduling features, but unable to consider the particular challenges of scattered repetitive projects planning and construction. Most of the scheduling systems are CPM-based which are not suitable for projects with scattered and repetitive nature (discussed in chapter 2). Their planning and scheduling features consider each small project as a separate and independent project. They do not recognize the multiple-locations nature of these projects and the multiple-crew strategies and, therefore, cannot be implemented. Moreover, the existing systems do not incorporate or present the massive volumes of data generated by scattered infrastructure rehabilitation projects during construction in a useful and easy to understand format, nor do they show the movement of crews and the speed of actual progress among scattered sites. The construction progress tracking and project control aspects are lacking in current systems. Accordingly, they do not incorporate as-built events into the schedule during construction, to allow project performance analysis and to facilitate corrective action planning.

Having an effective scheduling and control tool along with effective project delivery method that recognizes and benefit from the repetitive nature of these projects, minimizes the impact of the scattered nature and the effect of travelling distance; considers the local conditions of each site, incorporates daily site progress events, facilitates corrective actions; minimizes administrative efforts; and benefits from the economy of scales would significantly enhance public-sector organizations ability to realize significant cost savings and successfully complete their infrastructure renewal projects on time and on budget.

### **3.6 Discussion and Summary**

School boards, universities, and other public-sector organizations are challenged with substantial infrastructure renewal backlog that risks the sustainability of essential services to the public. Significant efforts were dedicated to optimizing the allocation of the limited funding resources available for infrastructure renewal. Little efforts, however, addressed the implementation and the delivery phase of such projects. Most of the existing management systems at public-sector organizations provide limited decision support to the in-house management teams during the execution phase of infrastructure rehabilitation projects with regards to the execution planning and the project delivery methods. The current practices in delivering infrastructure renewal programs at two large public organization were investigated and the challenges encountering the construction teams were discussed.

Infrastructure rehabilitation projects are repetitive in nature and scattered across large geographical areas (schools, buildings, etc.). However, considering every site separately deprives these organizations of benefiting from repetitiveness and minimizing the impact of the scattered nature. Furthermore, the current project management systems are not suitable to address the challenges of scattered repetitive projects. Moreover, the control aspect of these systems is lacking and therefore, identifying and implementing corrective actions during constructions is a very challenging task. The traditional DBB delivery method is ineffective and is not suitable for the unique characteristics of infrastructure rehabilitation projects.

These major challenges lead to cost overruns, schedule delays, and incomplete implementation of the infrastructure renewal programs. The project management professionals agree that developing an effective scheduling and control system along with effective and flexible project delivery method would increase the chances of completing projects on time, on budget, and with a higher level of all stakeholder's satisfaction. This would result in significant economic and social impacts through more efficient utilization of the limited funds and maximizing the benefits of the invested public capital

Next chapters will discuss the development of the proposed scheduling and control framework to address some of the challenges described in this chapter. In addition, a modified project delivery method that is suitable for the scattered repetitive projects is introduced.

## **Chapter 4**

### **Framework for Scattered Repetitive Scheduling and Control**

#### **4.1 Introduction**

This chapter introduces the components of the proposed scheduling, control, and cost optimization framework for scattered repetitive projects during the planning and construction phases. The framework uses the basic repetitive CPM-LOB formulation to calculate the duration and the cost for each individual activity as well as the number of crews required to meet the deadline and maintain work continuity. To consider the practical challenges that are commonly encountered in delivering scattered projects (discussed in Chapter 3), a new representation of the schedule is presented to improve the graphical representation and enable the optimization of the sequence of work for all crews. In addition, the proposed framework uses the Critical Path Segment (CPS) technique to better reflect actual progress events on the schedule to facilitate corrective action planning. Detailed design of the framework formulation is presented in this chapter with the implementation details discussed in the next chapter.

#### **4.2 Components of the Proposed Framework**

The proposed framework for scheduling, tracking, and control of scattered repetitive projects incorporates four main components as shown in Figure 4.1:

1. Basic Formulations: Integrated CPM/LOB;
2. Practical Scheduling Constraints;
3. Project Tracking and Control; and
4. Cost and Scheduling Optimization.

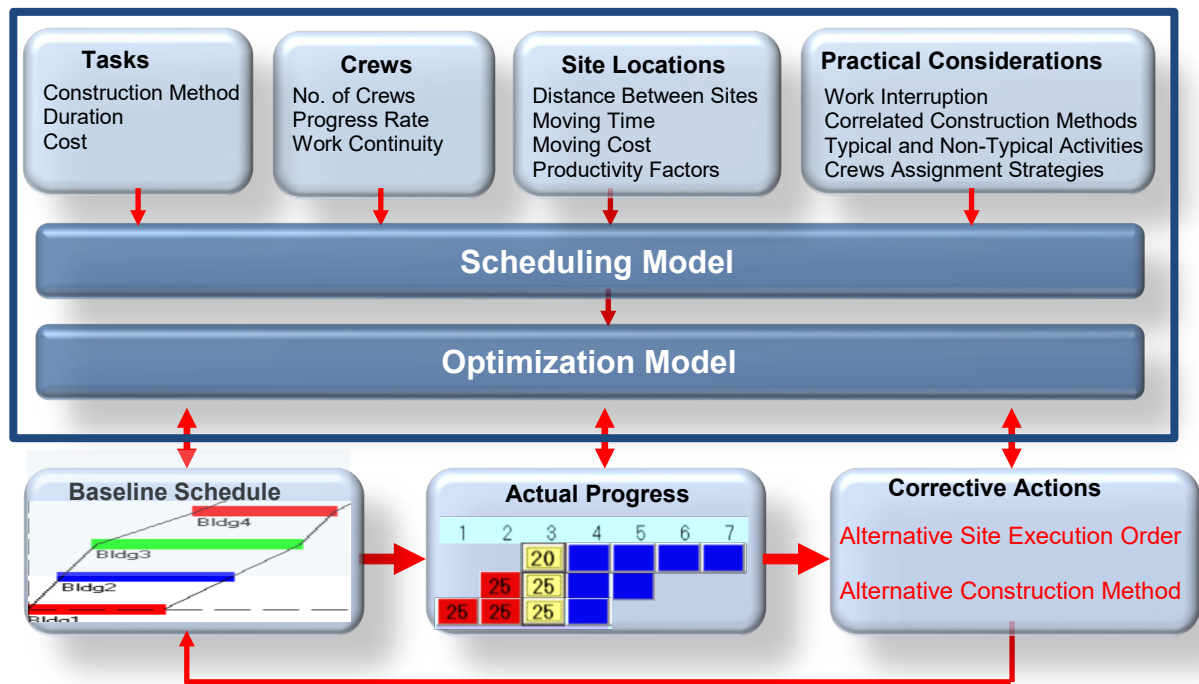

**Figure 4.1: Components of the Proposed Scheduling and Control Framework**

### 4.3 Basic Formulation: Integrated CPM/LOB Scheduling

The basic model underlying the proposed framework integrates the CPM method (for network analysis within each repetitive site) and the LOB method (for the analysis of repetitive sites). It calculates the number of crews that are required to meet a given deadline, under the following constraints: (a) logical relationships within each site; (b) logical relationships among sites; and (c) work continuity. The basic scheduling formulation involves three aspects:

1. Estimating of the duration and cost of individual activities;
2. CPM calculations for a single site; and
3. Production rate and number of crews to meet deadline.

The basic formulas used for section 4.3 are generic and could be applied to all types of repetitive projects. These formulas were previously used to develop scheduling models for various types of repetitive projects. Hegazy and Kamarah (2008), for example, modified these formulas to develop a scheduling and cost optimization model for high-rise building projects.

### 4.3.1 Activities' Durations and Costs

To provide flexibility and various options for cost and time optimization, the scheduling model allows repetitive activities to have up to three construction methods (from cheap-and-slow to fast-and-expensive), with their associated number of crews, durations, and costs. The scheduling algorithm first calculates the duration ( $d_{ijk}$ ) that a crew takes to complete the work of an activity ( $i$ ), using construction method ( $j$ ), at a typical site ( $k$ ) as follows:

$$d_{ijk} = Q_{ijk} / (Pr_j * f_{kL}) \quad (4.1)$$

where  $Q_{ijk}$  is the quantity of work for an activity ( $i$ ) using construction method ( $j$ ) at site ( $k$ );  $Pr_j$  is the production rate for the crew used in construction method( $j$ );  $f_{kL}$  is the productivity factor (from 0 to 1), at site ( $k$ ) during month ( $L$ ). The direct costs for each activity are then calculated as follows:

$$c_{ijk} = d_{ijk} * c_{ij} \quad (4.2)$$

where;  $c_{ijk}$  is the direct cost of an activity ( $i$ ) using construction method ( $j$ ) at a site ( $k$ );  $c_{ij}$  is the sum of the cost per day of activity ( $i$ ) using construction method ( $j$ ).

For example, if the daily production rate of a concreting crew is 100 cubic meters per day. This crew is assigned to pour a specific concrete slab that has a quantity of 200 cubic meter, given that the crew will work at 100% productivity (i.e.,  $f_{kL}=1.0$ ) and the daily cost of such crew is \$100,000. Using Equation 4.1, the duration of such activity will be  $200 / (100 * 1.0) = 2$  days. Using Equation 4.2, the total cost of the activity will be  $\$100,000 * 2 = \$200,000$ .

The productivity factor ( $f_{kL}$ ) adjusts the duration estimate for an activity to account for practical factors that describe the environment under which the work is performed. Some of these factors include: (1) local weather conditions; (2) working in occupied facilities; (3) unforeseen conditions; (4) level of design change and rework; (5) local municipalities by-laws; (6) local unions jurisdictions; and (7) level of management and supervision. Among these factors, unfavorable weather conditions can greatly impact the work on outdoor activities such



as excavation, concrete forming, reinforcement, framing, building envelopes, site services, paving, and landscaping. Interior activities are also impacted because finishing activities such as boarding and taping, flooring, millwork, etc. cannot proceed until the building is watertight (i.e., cladding, windows, and roofing are installed). Productivity peaks in summer because of good weather conditions, drops in fall due to increased number of rainy days, and decreased significantly in winter, particularly in cold regions where snow falls, and the temperature drops well below zero. Dangerous weather conditions such as high-speed wind could result in shutting down construction sites. Furthermore, materials delivery takes longer, and the chances for workers' absenteeism are much higher during unfavorable weather. Hegazy and Kamarah (2008) used monthly seasonal productivity factor ( $f$ ) that adjusts the time and cost estimates of activities as shown in Table 4.1.

**Table 4-1: Seasonal Productivity Factor (Hegazy and Kamarah 2008)**

Month	Factor( $f$ )	Month	Factor ( $f$ )	Month	Factor( $f$ )
January	0.7	May	0.85	September	1
February	0.7	June	1	October	0.85
March	0.7	July	1	November	0.85
April	0.85	August	1	December	0.7

Working within a currently operating facility (e.g., a running school or a hospital) is another significant productivity factor that does not exist in the case of new construction. Thus, it is expected that the construction work will proceed with less productively while the facility is running, to avoid disruption to the running service. For example, construction work that causes health/safety hazard, dust, noise, or limited access will have to slow down. Therefore, for these cases, proper productivity factors need to be used and is expected to lead to additional time and cost to the project. The productivity factors vary from one project to another and should be assessed on case by case bases. For example, working in occupied facilities would reduce the productivity by approximately 20%. If the work is scheduled in winter, the productivity factor would be further reduced by another 10% and so on. These estimates are for cold regions such as Ontario, Canada and are estimated based on experience with similar projects.

### 4.3.2 CPM Calculation for Single Site

Since each repetitive site has a network of activities, the CPM technique becomes necessary to calculate the total duration and the activity times for a typical repetitive site. Based on activities' durations, the critical path duration of typical site  $CPM_0$  ( $T_1$ ), the total float ( $TF_i$ ) of each activity ( $i$ ) is then calculated. For example, consider a typical unit of four activities A (6 days), B (24 days), C (5 days), and D (10 days), as shown in Figure 4.2. The CPM calculations use the activity's duration estimates that correspond to the method of construction being used for the activities. While cheaper option is used to calculate the initial  $CPM_0$  for a typical site, the other estimates are used in the cost optimization model (described in section 4.6) to crash project duration and/or to meet other constraints, if necessary.

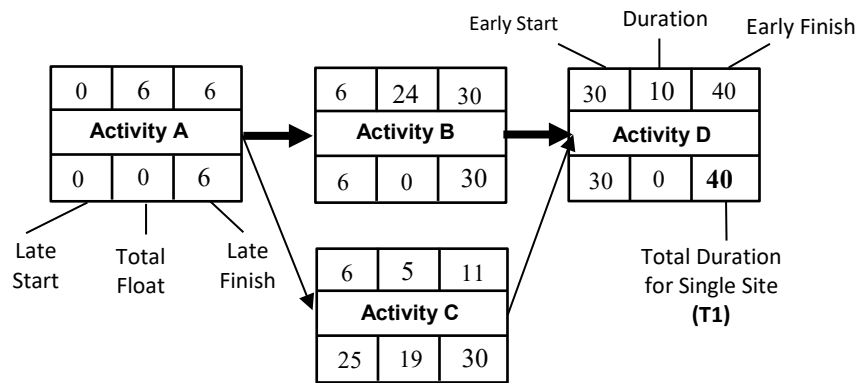

Figure 4.2: CPM Calculations for Single Site

### 4.3.3 Production Rates and Number of Crews to Meet Deadline

To improve the LOB schedule representation of repetitive projects, the proposed scheduling framework uses a modified CPM-LOB representation shown in Figure 4.3. The schedule shows five repetitive activities with several flexible features:

- Color-coded crews that show the crews' movement along repetitive sites;
- Varying quantity of work in each site (i.e., different duration in different sites); and
- Designed work interruption time and moving time between sites.

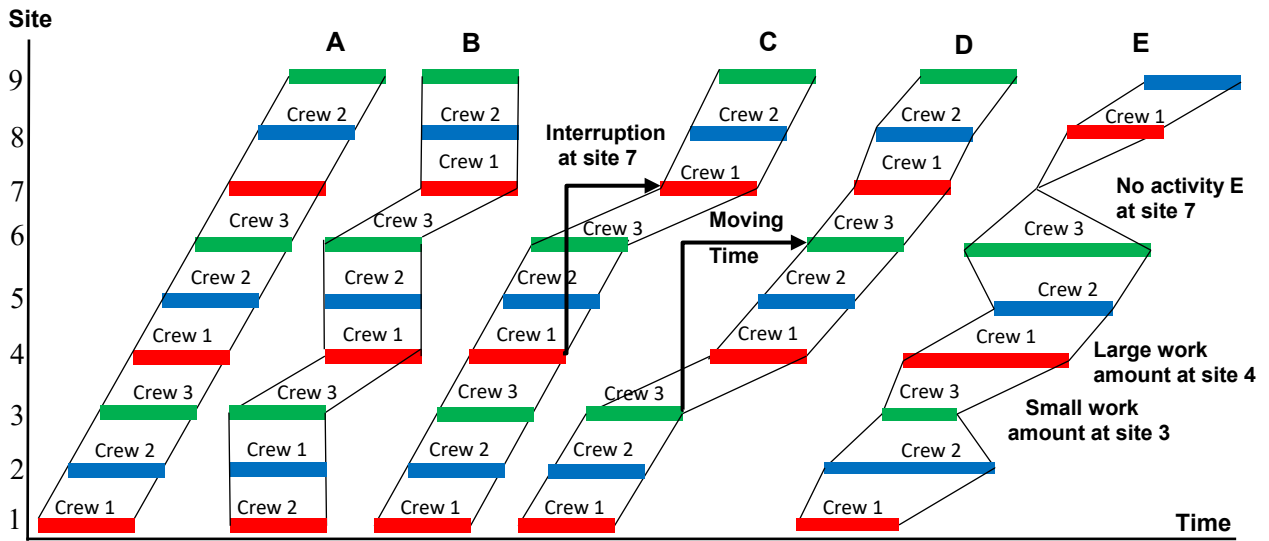

Figure 4.3: Various Schedule Features for 9 Repetitive Activities

After the duration of the first repetitive site ( $T_1$ ) is calculated using CPM, the remaining  $(s-1)$  repetitive sites need to be delivered in the remaining time, which is the  $(\text{Deadline} - T_1)$ . Therefore, the activities' progress rate ( $R$ ) needed to meet the deadline  $T_{DL}$  is calculated as follows (Hegazy 2002):

$$R = \frac{\text{Remaining sites}}{\text{Remaining time}} = \frac{(s-1)}{(T_{DL}-T_1)} \quad (4.3)$$

Figure 4.4 shows a sample of four repetitive activities, where A, B, and D are critical activities, while activity C is non-critical. Using Equation 4.3, the progress rate ( $R$ ) will be imposed on all critical activities (have zero total float time) to meet the required deadline, while non-critical activities (have total float times) will have slower progress rates that are proportionate with their respective total floats. Accordingly, the progress rate ( $R_i$ ) for any activity ( $i$ ) with total float ( $T_{Fi}$ ) can be calculated as follows (Hegazy 2002):

$$R_i = (s - 1) / (T_{DL} - T_1 + T_{Fi}) \quad (4.4)$$

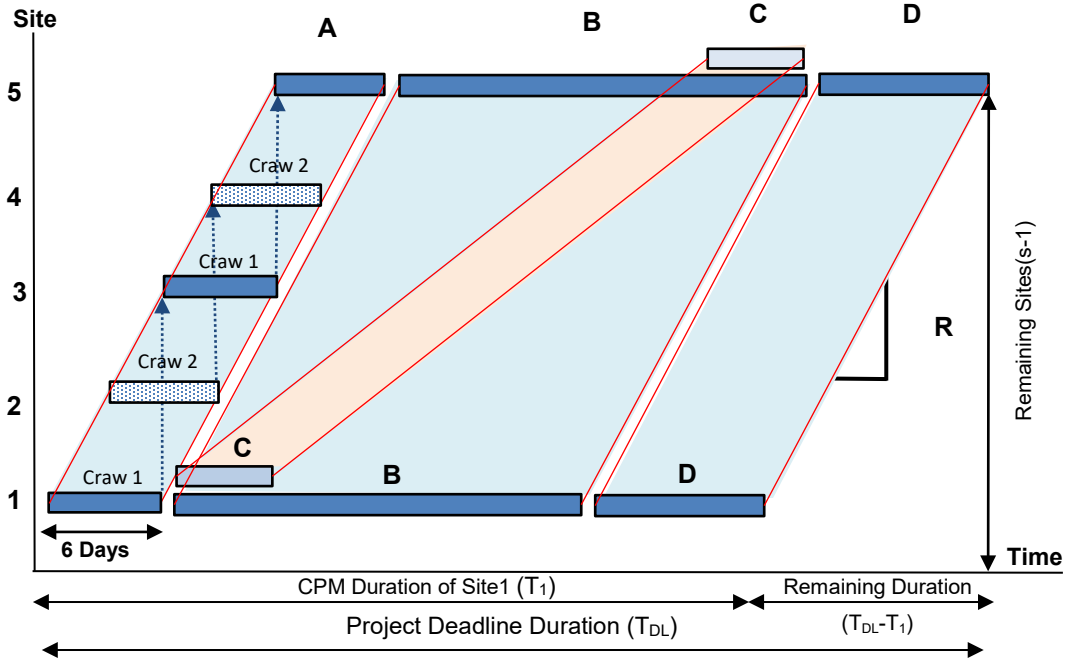

**Figure 4.4: Desired Progress Rate (R)**

For the example in Figure 4.4, the  $T_1$  duration of the first site is 40 days, as calculated in Figure 4.2. Given a 60-day deadline to finish all the five sites, therefore using Equation 4.4, the remaining four sites will have to be completed in 20 days, i.e., at the rate of  $[4/(60-40)] = 0.2$  site/day. This progress rate will be forced on critical activities A, B, and D. However, for non-critical activity C that has 19 days of float, its progress rate can be relaxed to become  $[4/(60-40+19)] = 0.1$  site/day.

With the calculated activity rates, the required number of crews for an activity ( $i$ ) to achieve a required progress ( $R_i$ ), given its duration  $d_{ij}$  that a crew takes to finish one site without interruption (i.e., work continuity and crew synchronization are maintained), using construction method ( $j$ ), is calculated as follows (Hegazy 2002):

$$Cr_i = R_i * d_{ij} \quad (4.5)$$

where  $Cr_i$  is the number of crews required to achieve production rate ( $R_i$ ) at duration  $d_{ij}$ . The calculated progress rate ( $R_i$ ) will be imposed on the critical activities to meet the required deadline. As an example of using Equation 4.5, on the five-sites project described in Figure 4.4, consider a critical activity A with 6-day duration and non-critical activity C with 5-day duration. Using the 0.2 site/day rate for the critical activity and 0.1 site/day rate for non-critical activity, the number of crews required to complete the critical activity  $A = 0.2 * 6 = 1.2$  crew while the number of crews required to complete the non-critical activity  $C = 0.1 * 5 = 0.5$  crew. The calculated number of crews using Equation 4.5 is not an integer value and needs to be rounded up to the next integer number to reflect the actual number of crews to be used. In addition, the number of crews that are needed to complete the work cannot exceed the available number of crews. Therefore, the actual number of crews ( $Cr_{ia}$ ) to be used to complete an activity ( $i$ ) becomes (Hegazy, 2002):

$$Cr_{ia} = (\text{Round Up } (Cr_i); Cr_{ia} \leq \text{Maximum Available Crews}) \quad (4.6)$$

Accordingly, the actual progress rate of each activity  $R_{ia}$  must be adjusted to reflect the actual number of available crews  $Cr_{ia}$ , as follows:

$$R_{ia} = Cr_{ia}/d_{ij} \quad (4.7)$$

As an example of this calculation, the critical activity A that needs 1.2 crews will be rounded up using Equation 4.6 to become 2 crews. Also, the non-critical activity C that needs 0.5 crew will be rounded up to 1 crew. Once the actual number of crews is determined, the start and finish times of the crews working at different sites for each activity can be calculated. For example, the 6-day critical activity A that uses 2 crews will appear as shown in Figure 4.4 with the crew work continuity maintained. Figure 4.4 shows the location of each crew at any given time. It shows crew 1 moves to site 3 after completed site 1 and then moves to site 5 while crew 2 moves to site 4 after completed site 2. It is noted that when the calculated number of crews using Equation 4.5 is changed due to rounding or limitation of resources, the revised number of crews and their associated progress rates using Equations 4.6 and 4.7 may not meet the required deadline and may not ensure work continuity.

#### 4.4 Practical Scheduling Constraints for Scattered Repetitive Projects

The framework calculations goal is to schedule critical activities as parallel as possible to maximize resources utilization. However, many practical conditions need to be accounted for, including:

1. Need to introduce designed periods of work interruption;
2. Variations of work quantities among the sites;
3. Optional and correlated construction methods;
4. Activities with different execution orders among the sites; and
5. Crew limits and assignment strategies.

It is essential, therefore, for the scheduling framework to have adequate flexibility to consider all these options, as discussed in the following subsections.

##### 4.4.1 Designed Work Interruption

The proposed framework calculates the start and finish times for each activity at all sites, which are functions of its duration, progress rate, number of crews, and interruptions. A designed work interruption in the scheduling model is a delay to the start of an activity from its calculated start time based on its progress rate ( $R_{ia}$ ).

A typical situation in which introducing an interruption is beneficial is when one or more fast activities are trapped between slower activities. As shown in Figure 4.5. an interruption  $I_{Bk}$  is introduced to activity  $B$  at site ( $k$ ). This strategy makes it possible to start the first part of activity  $B$  earlier than its original schedule. Accordingly, it is possible for the following activity  $C$  to start earlier. The reduction of project duration using this strategy, however, may result in compromising work continuity. The loss in continuity as a result of designed interruptions could be minimal if the number of sites is large, and the interruptions are effectively implemented (Hegazy, 2002).

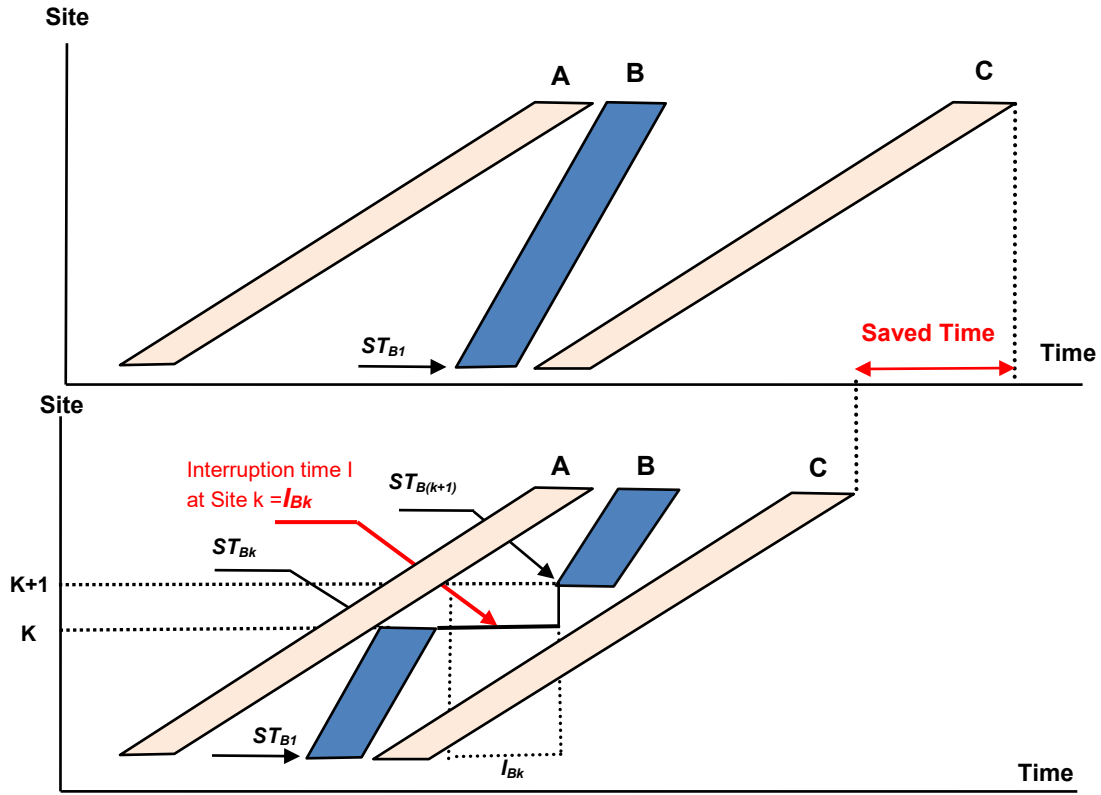

Figure 4.5 Designed Work Interruption

Activity  $B$  is shifted by  $I_{Bk}$ , thus allowed activity  $B$  at sites from site 1 to site  $(k)$  to start earlier than its original start time which enables activity  $C$  to start before its original start time and completed earlier than its original finish time. To accommodate the interruption  $I_{ik}$  for an activity  $(i)$  at site  $(k)$ , the start time  $ST_{i(k+1)}$  and the finish time  $FT_{i(k+1)}$  of an activity  $(i)$  at the successor site  $(k+1)$  that is using construction method  $(j)$  while adding work interruption  $(I_{ik})$  to the duration  $(d_{ijk})$  are calculated as follows:

$$ST_{i(k+1)} = ST_{ik} + d_{ijk} + I_{ik}, \quad k = 1, 2, 3, \dots \dots \dots S \quad (4.9)$$

$$FT_{i(k+1)} = ST_{i(k+1)} + d_{ij(k+1)}, \quad k = 1, 2, 3, \dots \dots \dots S \quad (4.10)$$

#### 4.4.2 Variation of Work Quantities at Different Scattered Sites

In a large infrastructure renewal project with multiple scattered sites, not all sites have the same amount of work for each activity. It is convenient, therefore, to consider that all sites to be “Typical” sites to simplify data entry since it is possible to specify the site data once for all the typical sites. Special sites can then be specified separately. When considering each activity at a time, the scheduling model uses the term *Typical Site* to describe the duration and cost of an activity at a *Typical Site*, and the term *Non-Typical Site* to describe the duration and cost of any other site that differs from the *Typical Site* as shown in Figure 4.6.

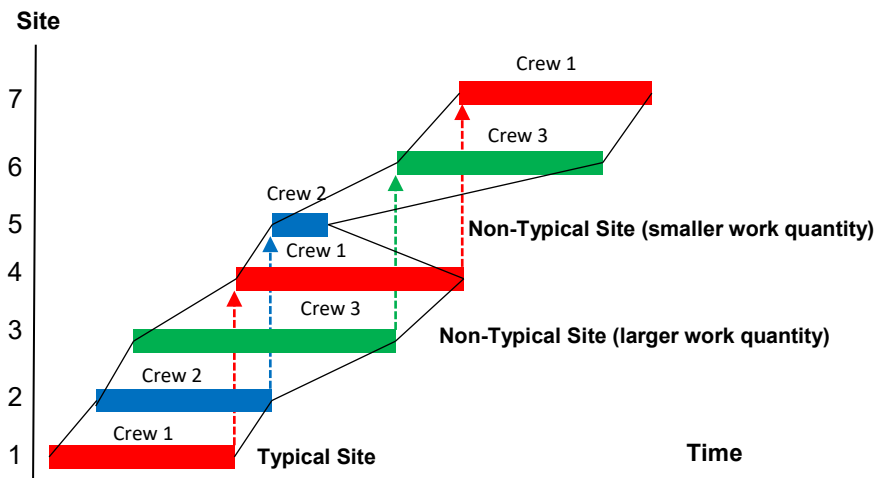

Figure 4.6: Variation of Work Quantities along Different Sites

Figure 4.6 shows an activity that has typical durations at site 1 and site 2. Site 5, however, has a shorter duration, either due to a reduced amount of work or an increased productivity at this site. Site 3, on the other hand, has a longer duration than the typical site, either due to an increased amount of work or a reduced productivity at this site. To specify that an activity uses non-typical durations and costs, a simple approach is to specify a percentage of the typical site. Accordingly, the activity duration and cost of this non-typical site is calculated automatically. If a percentage of 50% is assigned for an activity at a non-typical site, it means that the activity duration is 50% of the duration for typical site (Kamarah and Hegazy, 2017). This feature allows the project team to account for the reduced (or increased) amount of activity work at different sites which could be also identified in the form of a Grid as shown in Table 4.2. In



some cases, some activities are not available at every site. By assigning 0% of the typical site, the model will consider this activity as not available at this site. Using grid allows the project team to identify the cost and duration for all repetitive activities once and modify these costs and durations using the percentage for non-typical sites. Using percentages instead of actual quantities saves a step in the internal calculation and avoid repeating the elemental calculations every time quantities are changed. The percentage of typical activity, on the other hand, allows this to be calculated automatically to avoid recalculating basic activity information every time the work quantity changes.

**Table 4-2: Variation of Work Quantities along Scattered Sites**

	Site 1	Site 2	Site 3	Site 4	Site 5	Site 6	Site n
Activity 1	90%	100%	100%	50%	100%	125%	
Activity 2							
Activity 3							
Activity 4							
Activity 5							
Activity 6							
Activity n							

#### 4.4.3 Optional and Correlated Construction Methods

The framework allows activities to have up to 3 construction methods from (cheap and slow method) to (fast and expensive method). Accordingly, each activity will have various construction options with their associated number of crews, durations, and costs. For example, the first method is to employ a regular sub-contractor who works normal hours (8 hours/day). The second method is to pay the same sub-contractor a premium to work overtime (12 hours/day). This method is faster than the first method but cost more. The third method is to use another sub-contractor who has larger-size crews and more efficient machinery. This method finishes the activities faster than the previous methods, but cost significantly more.

Because some subcontractors can be involved in more than one activity and usually follow their own construction methods, thus, it is possible that the use of a particular construction

method for one activity (e.g., a certain subcontractor) mandates the use of the same method (same subcontractor) for another task. For example, even though structural framing is divided into two activities; columns and slabs, they must be executed by the same sub-contractor. Therefore, if construction Method 1 is selected for columns, construction Method 1 or 2 must be selected for slabs since both methods are carried out by the same sub-contractor. If construction Method 3 is selected for columns (i.e. other sub-contractor) then construction Method 3 must be selected for slabs.

**Table 4-3: Constrained Construction Methods**

Driving Construction Method	Dependent Construction Method
Construction method 1 is selected for Excavation	Use construction method 1 or 2 for Backfilling
Construction method 3 is selected for Excavation	Use construction method 3 for Backfilling
Construction method 1 is selected for Columns	Use construction method 1 or 2 for Slab
Construction method 3 is selected for Columns	Use construction method 3 for Slab
Construction method 1 is selected for Slab	Use construction method 1 or 2 for Columns
Construction method 3 is selected for Slab	Use construction method 3 for Columns
Construction method 1 is selected for Metal Studs	Use construction method 1 or 2 for Board/Tape
Construction method 3 is selected for Metal Studs	Use construction method 3 for Board/Tape
Construction method 1 is selected for Mech roughing	Use construction method 1 or 2 for Mech finishes
Construction method 3 is selected for Mech roughing	Use construction method 3 for Mech finishes
Construction method 1 is selected for Electric roughing	Use construction method 1 or 2 for Electric finishes
Construction method 3 is selected for Electric roughing	Use construction method 3 for Electric finishes

Excavation and backfilling activities must be performed by the same sub-contractor. Therefore, if construction Method 1 is selected for excavation, construction Method 1 or 2 must be selected for the backfilling, since both methods are carried out by the same sub-contractor. If construction Method 3 is selected for excavation (i.e. other sub-contractor) then construction Method 3 must be selected for backfilling. Also, Metal Stud and Board/Tape must be executed by the same sub-contractor. Therefore, if construction Method 1 is selected for metal stud, construction Method 1 or 2 must be selected for the board/tape, since both methods are carried out by the same sub-contractor. If construction Method 3 is selected for metal stud (i.e. other sub-contractor) then construction Method 3 must be selected for board/tape.

Mechanical work (i.e., Plumbing and HVAC) work is divided into two separate activities; roughing and finishes, they must be executed by the same sub-contractor. Therefore, if construction Method 1 is selected for roughing, construction Method 1 or 2 must be selected for the finishes, since both methods are carried out by the same sub-contractor. If construction Method 3 is selected for roughing (i.e. other sub-contractor) then construction Method 3 must be selected for finishes. Similarly, Electrical work is divided into two separate activities; roughing and finishes, and they must be executed by the same sub-contractor. Therefore, if construction Method 1 is selected for roughing, construction Method 1 or 2 must be selected for the finishes, since both methods are carried out by the same sub-contractor. If construction Method 3 is selected for roughing (i.e. other sub-contractor) then construction Method 3 must be selected for finishes.

#### **4.4.4 Representation of Variable Execution Orders**

Traditional LOB charts represent the planned start and finish times of the activities for each unit, as shown before in Figure 4.3, where the crews move along the units. This representation works well with projects of linear nature such as highways, pipelines, and railways. It also works well with projects of vertical nature such as high rise. In both cases, the y-axis is the sequential number of the unit (floor). For scattered projects, on the other hand, the distributed and scattered nature of the sites mandate the use of a GIS system of maps to show the location of each site.

Because each activity can have a different independent sequence of work among the sites, plotting the schedule using sequential sites becomes problematic. Figure 4.7 shows a LOB schedule for a project of two activities along seven scattered sites. The chart shows a side map of the sequence of sites for the two activities' crews. Activity A uses one crew that moves according to the following sequence (shown on the left-side map): 2-6-7-1-3-5-4. Activity B, on the other hand, uses two crews (shown on the right-side map), as follows: (crew 1: 2-6-7-1); and (Crew 2: 3-5-4). In both cases, the use of a sequential site number on the vertical axis

makes the schedule complex to read, particularly if more than one activity is shown on the schedule simultaneously.

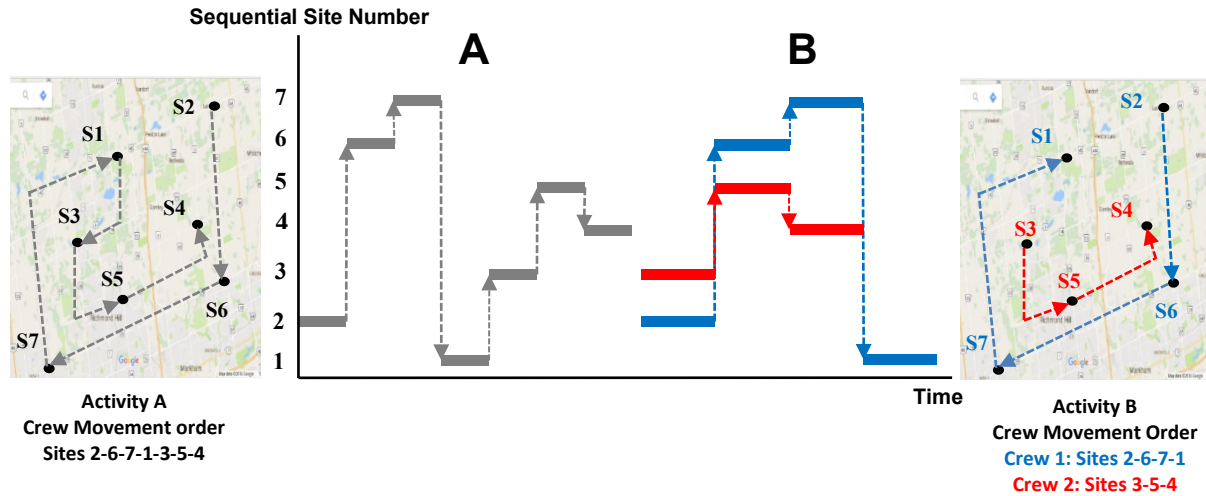

Figure 4.7: Traditional LOB Representation for Scattered Repetitive Projects

One suggested improvement to the LOB representation for scattered repetitive projects is to adjust the site indices on the vertical axis to match the site orders of all activities, as shown in Figure 4.8, where the schedule is much easier to read and identify the work sequence of each crew legibly, with the two activities A and B shown together in the schedule.

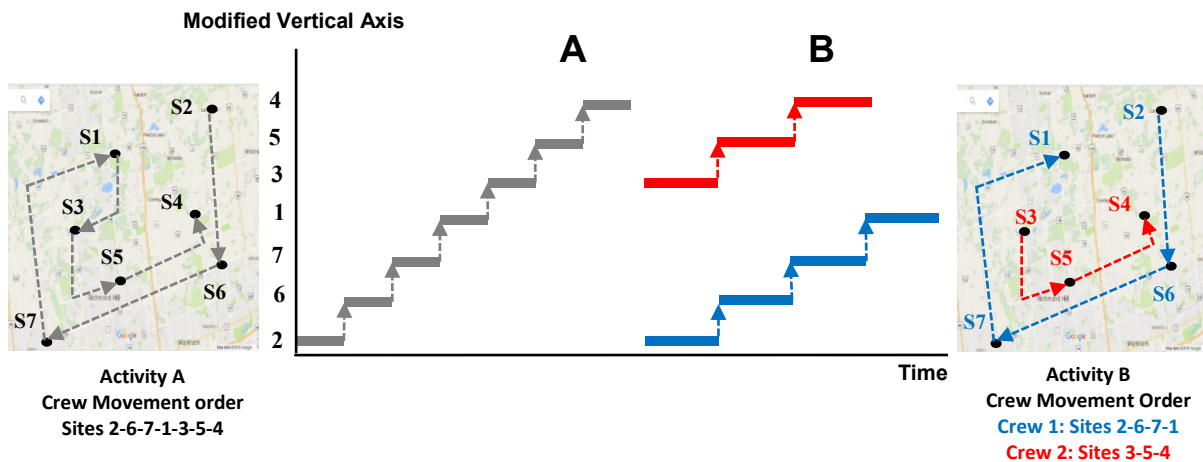
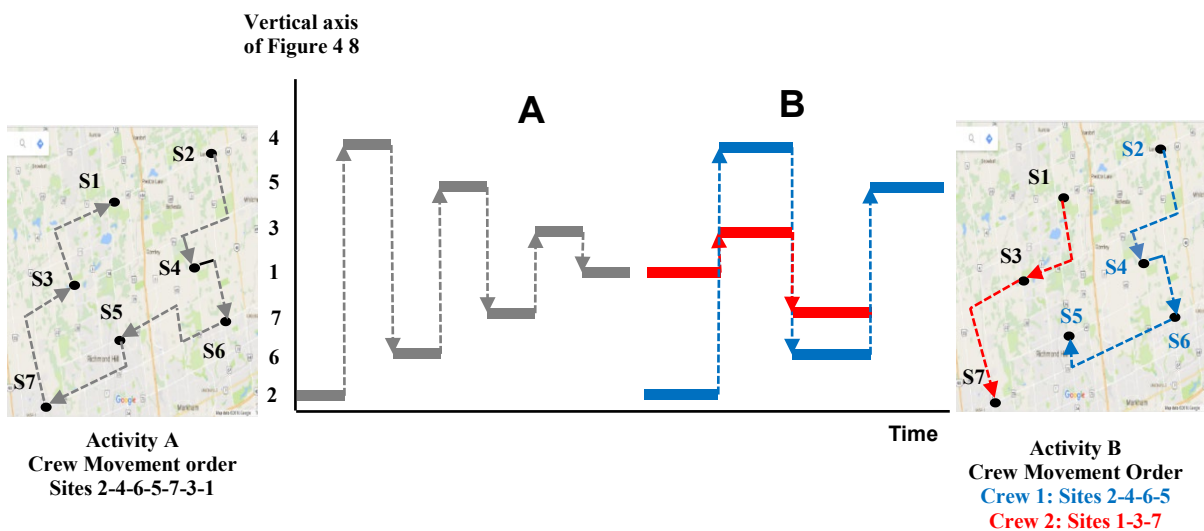

Figure 4.8: Modified Vertical Axis for Scattered Repetitive Projects

In more complex schedules with many activities, however, it may not be possible to define the suitable vertical indices that suit the crew movements of all activities. Also, in the case that the work sequence is changed during construction, the schedule will also become complex to read. This is shown in the case of Figure 4.9, where the two activities A and B happened to involve different work sequences than the initial plan of Figure 4.7. The vertical axis, in this case, does not suit the new work arrangement anymore.



**Figure 4.9: Changing the Work Sequence of Activities A and B Creates a Complex Schedule**

To resolve the visualization problem in the schedule of scattered units, a generic schedule representation is proposed in this study, which uses the vertical axis as a variable site index. Basically, each activity will have the sequence of each crew is drawn independently, yet maintaining work continuity, as shown in Figure 4.10. The figure shows the work sequence of the single crew of activity A with the site index written on each unit. Similarly, the work sequence of each of the two crews of activity B is drawn separately. Such a legible representation allows the schedule to show any number of activities, crews, and sites in an easy to read format.

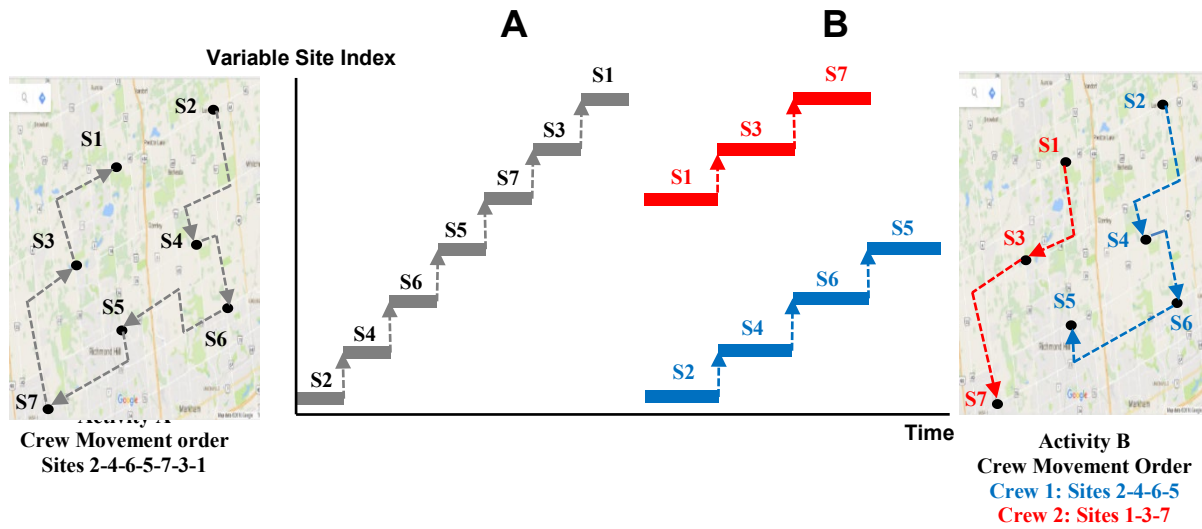

**Figure 4.10: Proposed Schedule Representation with Variable Site Index**

#### 4.4.5 Moving Time and Cost

Due to the scattered nature of infrastructure renewal projects, the crews' movements among sites (e.g., traveling, mobilization, demobilization, etc.) can take considerable time and cost, which need to be accounted for in a practical schedule. To account for crew moving time and cost, it is important to define the distance from one site to another, which can be input in a grid such as the one described in Table 4.4, or automatically calculated from the GIS system related to the work sequence of the crews.

Once the crew Moving Time  $MT$  and the Moving Cost  $MC$  are determined (Equations 4.11 and 4.12), their impact on the scheduled time and cost, and on deciding the optimum work sequence of each crew can be calculated.

$$\text{Moving Time (MT)} = \frac{\text{Distance}}{\text{Crew Moving Speed}} \quad (4-11)$$

$$\text{Moving Cost (MC)} = \text{Distance} * \text{Crew Moving Cost per km} \quad (4-12)$$

**Table 4-4: Moving Time and Distance**

Activity	Site	Site1	Site2	Site3			Site s
	Site						
1	S1		$(\$_{1-2}, D_{1-2})$	$(\$_{1-3}, D_{1-3})$			$(\$_{1-s}, D_{1-s})$
2	S2	$(\$_{2-1}, D_{2-1})$					
3	S3						
N	Ss	$(\$_{s-1}, D_{s-1})$					

To illustrate the effects of site sequence and moving time/cost on the schedule, consider a schematic example of an activity using one crew that has two optional site execution orders along seven scattered units. The case in Figure 4.11a shows the crew deployed according to the sequence: 2-6-7-1-3-5-4, which indicates long distances traveled among the sites, as shown on the side map. Alternatively, as in Figure 4.11b, the project time and cost are reduced when the site order is changed to 2-4-6-5-7-3-1(Kamarah and Hegazy, 2017).

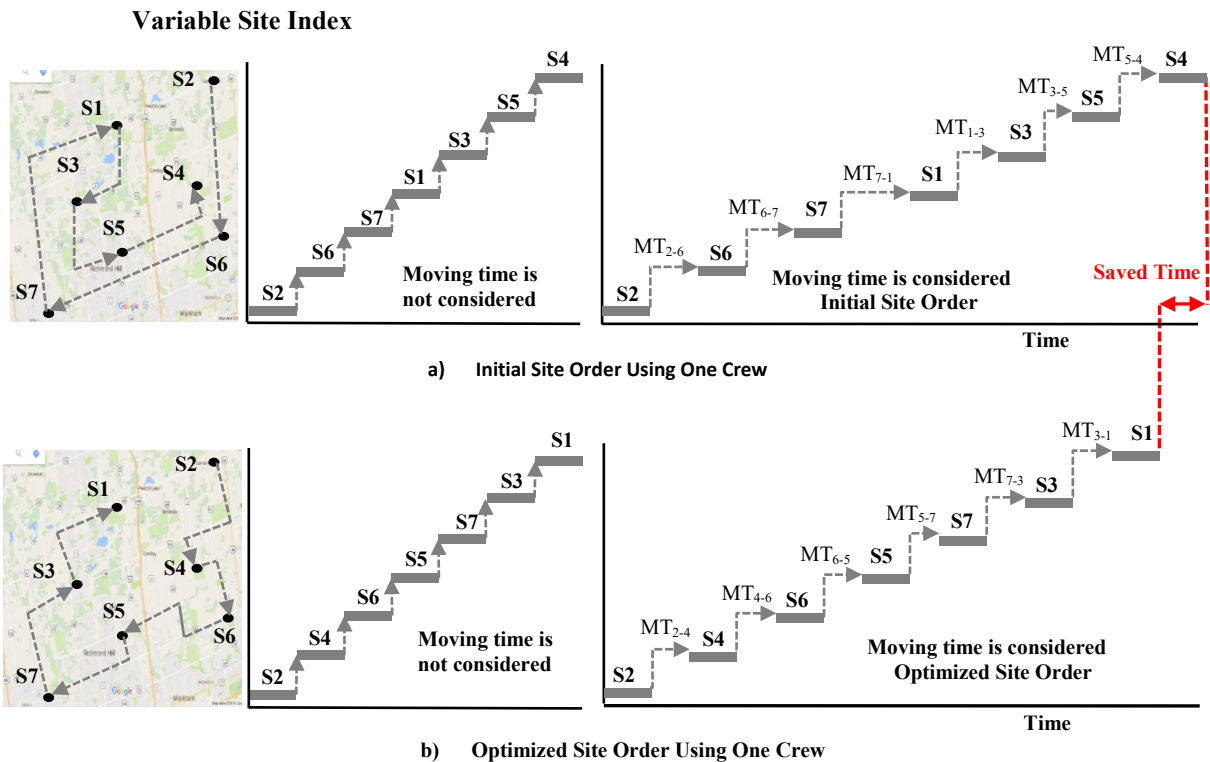

**Figure 4.11: Moving Time Impact Using One Crew and Different Execution Orders**

Similarly, time and cost can be saved when selecting the proper work sequence in the case of using multiple crews (two crews in the example of Figure 4.12).

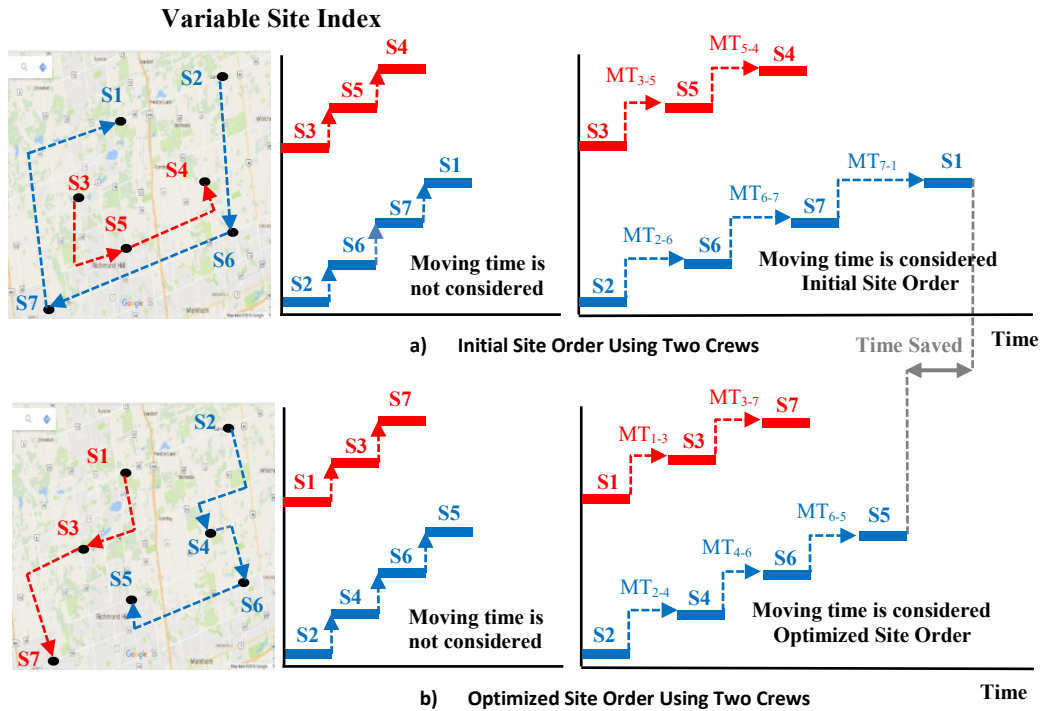

**Figure 4.12: Moving Time Impact Using Multiple Crews and Different Execution Orders**

#### 4.4.6 Crew Limits and Assignments Strategies

One of the key practical considerations in repetitive scheduling in general, and scattered projects in particular, is to consider the available limit of the working crews. This will affect the schedule in terms of time and cost and mandate the use of optimization to bring the schedule within the project deadline, as discussed later. Also, to overcome the challenge of different work amount and different productivity along the scattered sites, it is advantageous to assign the crews to the sites based on a first-come-first-served basis to save time, as opposed to the traditional sequential assignment in the LOB method.



Figure 4.13a shows an example of assigning three crews along seven scattered sites in a sequential fashion, i.e., crew 1 (marked in red) is assigned to sites 1, 4, and 7 while crew 2 (marked in blue) is assigned to sites 2 and 5, and crew 3 (marked in green) is assigned to sites 3 and 6. This strategy caused crew 2 to leave the site early after completing site 5 although site 6 is open for work and has to wait for crew 3 to finish site 3. A better schedule can be generated by assigning crew 2 to site 6 immediately after completing site 5 as shown in Figure 4.13b. Adapting this first-come first-served strategy, thus, improves the schedule, avoid idle time, and maximize the utilization of the working crews (Kamarah and Hegazy, 2017).

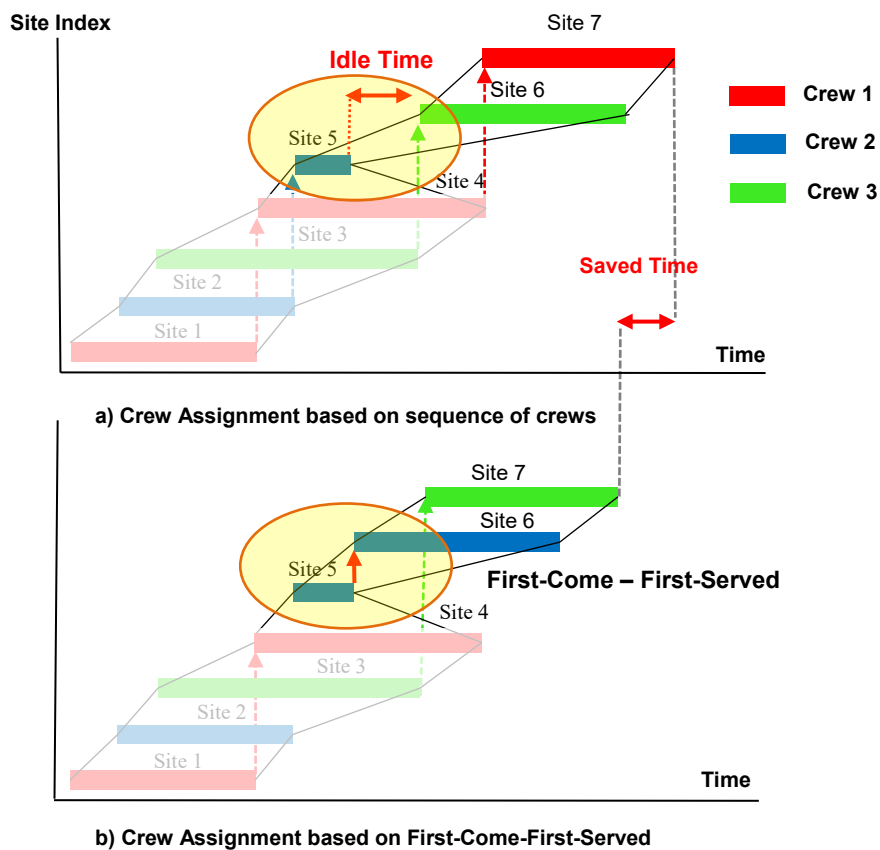

**Figure 4.13: Improved Crews Assignment Strategy**

Considering the moving time between sites, work interruption, and utilizing first-come- first-served strategy, the Start Time ( $ST$ ) and the Finish Time ( $FT$ ) of each activity ( $i$ ) at each site ( $k$ ) (shown in Figure 4.14) can be calculated as follows (based on Hegazy, 2006):

$$ST_{ik} = \text{Min}[\sum_1^{Cria} (FTC_{Crv} + MT_{vk})] + I_{ik} \quad (4.13)$$

$$ST_{ik} \geq \text{Finish Time of Predecessors} \quad (4.14)$$

$$FT_{ik} = ST_{ik} + d_{ijk} \quad (4.15)$$

where  $ST_{ik}$  is the Start Time for activity ( $i$ ) at site ( $k$ ),  $FTC_{Crv}$  is Finish Time of Crew  $Cr$ , ( $Cr$ ) is crew number  $\{1,2,.. Cria\}$ , ( $v$ ) is the previous site the crew  $Cr$  was involved in,  $MT_{vk}$  is moving time from previous site ( $v$ ) to site ( $k$ ) that is being scheduled, ( $I_{ik}$ ) is the interruption time at site ( $k$ ), and  $FT_{ik}$  is the Finish Time for activity ( $i$ ) at site ( $k$ ).

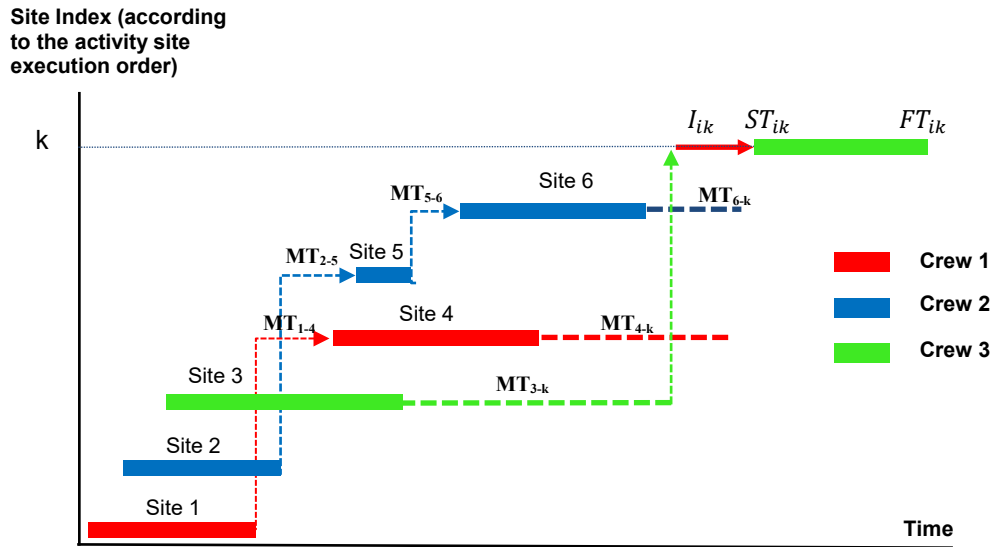

Figure 4.14: Crew assignment (First-Come-First-Served) Strategy Calculation

## **4.5 Project Control for Scattered Repetitive Projects**

The previous sections discussed the schedule formulation needed to determine a project baseline schedule. Changes to this baseline schedule during construction are inevitable and the project team needs an efficient tool to support corrective action planning in order to maintain the project schedule and budget. The proposed framework, therefore, incorporates procedures to update the schedule based on actual progress data and accordingly determining the optimized corrective actions to ensure the time and cost objectives of the project are achieved.

### **4.5.1 Representation of Daily Progress Events**

A key challenge to efficient tracking and project control is the inability of the existing scheduling tools to utilize and integrate the evolution of various daily as-built events caused by all parties involved in the project such as interruptions, materials delivery delays, rework, acceleration, weather condition, labor unrest, etc. The current tools are only capable of presenting basic progress information such as start date, finish date, actual duration, and percentage complete. This limited representation does not provide sufficient information for proper performance analysis and effective corrective actions planning.

These drawbacks are more apparent when applied to infrastructure scattered repetitive projects due to their large size, scattered and complex nature, and the massive volume of information they generate during construction. As such, tracking and control of this type of projects become more challenging and subject to mistakes. The current systems are incapable of accurately incorporating the evolution of projects at each scattered site on the schedule to allow accurate assessment of the project status and enable proper utilization of resources in order to avoid project delays and cost overrun. Therefore, to improve the ability of project teams to deliver these projects successfully, an effective tracking and control system is needed to document more granular daily progress events, and parties responsible for these events, so that collected as-built details are incorporated into the schedule to allow for proper project performance analysis and identifying effective corrective actions.

To achieve that, the proposed framework extends the representational advantages of the Critical Path Segment (Hegazy and Menesi, 2010, 2012) to the environment of infrastructure renewal scattered repetitive projects. The proposed framework combines the benefits of CPS and LOB and extends CPS-LOB formulation (Hegazy et al. 2014) to facilitate tracking and control for infrastructure renewal scattered repetitive projects.

CPS-LOB divides each repetitive activity duration into daily consecutive segments with a modified calculation for the duration segments within each site. In addition, the CPS-LOB provides detailed daily as-built events, where owners, consultants, authorities having jurisdictions, and contractors' interruptions are indicated on the schedule (an O indicates owner, and C indicates contractor, and N indicates other interruptions such as unfavorable weather, labor unrest, unforeseen conditions,). Daily progress amount is also shown as a percentage of the total planned activity duration, as shown in Figure 4.15.

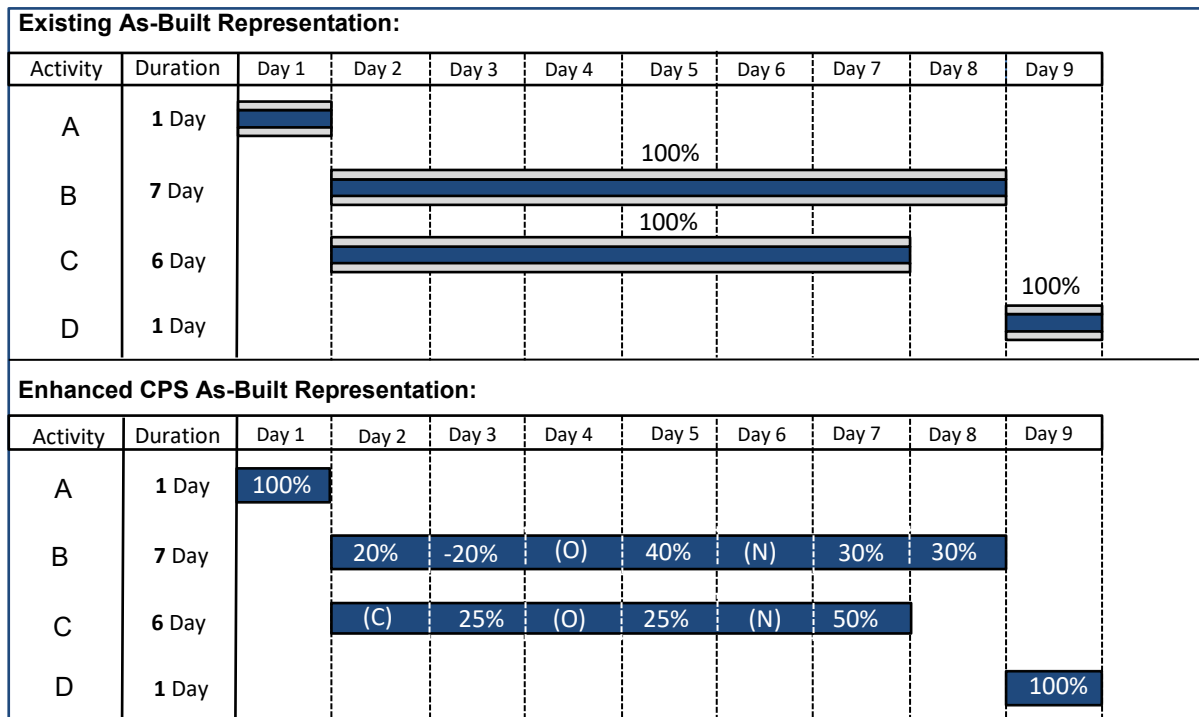

**Figure 4.15 Critical Path Segments (CPS) As-Built Representation**

To illustrate the benefits of CPS-LOB daily as-built events representation of the schedule, consider the hypothetical four activities renovation project in an educational occupied facility in Figure 4.15. Activity A has a planned duration of one day, activity B has a planned duration of five days (i.e., planned progress rate of 20% per day), activity C has a planned duration of four days (i.e., planned progress rate of 25% per day) and activity D has a planned duration of one day. While activities A and D were completed on time, activities B and C have experienced delays due to various reasons that were caused by different parties.

Activity B for example, has progressed as planned at Day 2, while experienced a major delay at Day 3 because the work performed at Day 2 was deficient, and the contractor was instructed by the consultant to rectify the deficiency. At Day 4, the facility users had an important event and cannot allow any noise disruption to the event and requested the contractor not to work on that day. Therefore, the delay is marked at the schedule as an owner caused delay “O” to activity B. At the following day, and to make up the delay, the contractor has assigned two crews and completed 40% of the required work. At Day 6, the local union announced one day strike as they were in the middle of negotiating their collective agreement. Therefore, the delay to activity B is marked at the schedule as an interruption caused by others “N”. The workers returned to work the following day and worked an additional four hours at Day 7 and Day 8 to complete the work for activity B at the end of Day 8.

Activity C had a rough start as the material required to perform the work did not arrive, and no work took place at Day 2. The delay was marked as a contractor caused delay “C”. As the material has arrived on site the following day, the activity had progressed at the planned progress rate of 25% per day. The contractor was not allowed to work at the facility at Day 4, and the delay was marked as an owner caused delay “O”. At Day 5, the work has progressed at the planned progress rate of 25%. Similar to activity B, no work took place at Day 6 because of the strike and the delay is marked at the schedule as an interruption caused by others “N”. At Day 7, the contractor assigned two crews and completed the work by the end of the day.

Such a rich and detailed daily as-built information enables project managers to analyze the project performance and make informed decisions on appropriate corrective actions to bring

the project back on track shall the actual progress deviates from the baseline plan. Furthermore, such high resolution in the as-built schedule documents the reasons for any delay and the responsible parties of such delays for forensic analysis and delay claims if needed.

**4.5.2 Updating the Schedule Based on Progress Events**

Updating the project schedule to reflect the progress evolution requires an accurate formulation to calculate the activities’ durations considering actual duration to date and the remaining duration starting from the current date. Most of the existing software tools make inaccurate and unrealistic assumption that the remaining work will follow the planned progress rates, even if the completed work has proceeded at a different rate. This assumption miscalculates project deviation and could result in inaccurate corrective actions.

The proposed control framework calculates the duration of an activity during construction taking into the account the actual duration to date (shown in Figure 4.16) and to provide the project team with the necessary flexibility to accommodate various possible scenarios for calculating the remaining durations.

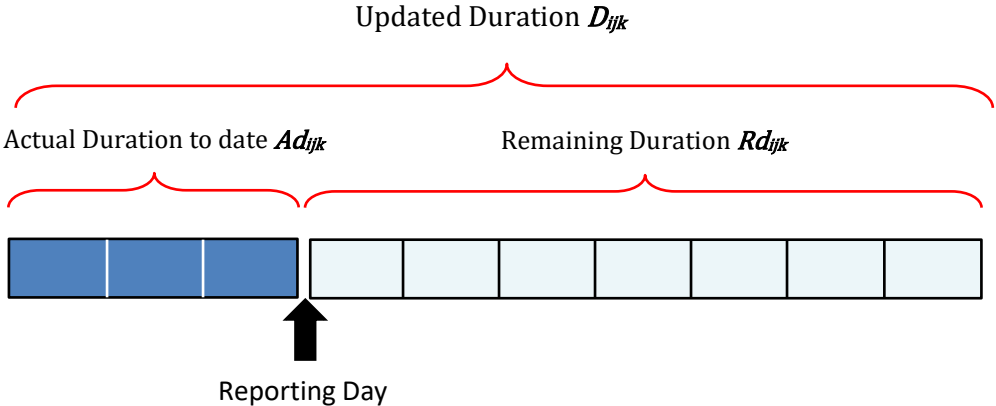

**Figure 4.16: Updated Activity Duration Calculations**

During construction, CPS-LOB adjusts the number of the daily segments associated with the planned duration  $d_{ijk}$  to reflect the updated duration and cost of each activity ( $i$ ), using construction method ( $j$ ) at any site ( $k$ ) considering actual duration to date, as follows:

$$\text{Updated Duration} \quad D_{ijk} = Ad_{ijk} + Rd_{ijk} \quad (4-16)$$

$$\text{Updated Cost} \quad C_{ijk} = Ac_{ijk} + Rc_{ijk} \quad (4-17)$$

where,

- $D_{ijk}$  is the updated activity duration;
- $Ad_{ijk}$  is the actual duration completed to-date;
- $Rd_{ijk}$  is the remaining duration;
- $C_{ijk}$  is the updated cost of activity ( $i$ );
- $Ac_{ijk}$  is the actual direct cost to-date; and
- $Rc_{ijk}$  is the remaining direct cost.

Calculating the remaining activity duration  $Rd_{ijk}$  and remaining activity direct cost  $Rc_{ijk}$  during construction depends on how the activity is expecting to progress from to-date on, which has two possible scenarios, as follows:

**Scenario 1 - remaining work follows actual progress:** In this case, with the activity percentage complete being  $Pc_{ijk}$ , then, the remaining percentage (i.e.,  $1 - Pc_{ijk}$ ) will progress following the actual rate. Thus, the updated activity duration and cost become:

$$D_{ijk} = Ad_{ijk} + Rd_{ijk} = Ad_{ijk} + \text{Round Up} [Ad_{ijk}(1 - Pc_{ijk}) / Pc_{ijk}] \quad (4.18)$$

$$C_{ijk} = Ac_{ijk} + (c_{ijk} * Rd_{ijk} / d_{ijk}) \quad (4.19)$$

**Scenario 2 - remaining work follows planned progress:** In this case, the remaining work will follow the planned progress rate. Thus, the updated activity duration and cost become:

$$D_{ijk} = Ad_{ijk} + Rd_{ijk} = Ad_{ijk} + \text{Round Up} [d_{ijk}(1 - Pc_{ijk})] \quad (4.20)$$

$$C_{ijk} = Ac_{ijk} + (c_{ijk} * Rd_{ijk} / d_{ijk}) \quad (4.21)$$

Which of these options depends on the activity situation. If the slow progress was a casual event and the activity environment has been improved, then the remaining work will follow the plan. If, on the other hand, the delay was due to lack of resources, then actual progress will more likely continue to follow the actual slow progress. In this case, corrective action may be warranted to avoid project overruns.

#### **4.5.3 Corrective-Action Decisions**

The proposed framework determines the necessary corrective actions to meet the time and cost objectives of the project after calculating activities' updated durations and costs. For scattered projects, the range of corrective actions includes the following:

1. Activity-level decisions: Change the construction methods to faster ones, for some activities;
2. Project/Schedule-level decisions:
  - a. Regenerate a revised repetitive schedule with designed interruptions to the fast activities that are trapped between slower activities (e.g., Figure 4.5); and/or
  - b. Change the site execution order among the repetitive sites (Figure 4.11 and 4.12).

These possible actions need to be applied differently for the various project activities, depending if the activity being one of the three categories that exist during construction: Completed Activities; Remaining Activities; and On-Going Activities (Figure 4.17), as follows:

**Completed Activities:** These activities have actual start dates, actual finish dates, and actual costs and their percentage complete is 100%. The proposed control framework considers these as static activities that cannot be updated or rescheduled, this will work as constraints on the schedule but will not take part in schedule optimization decisions.



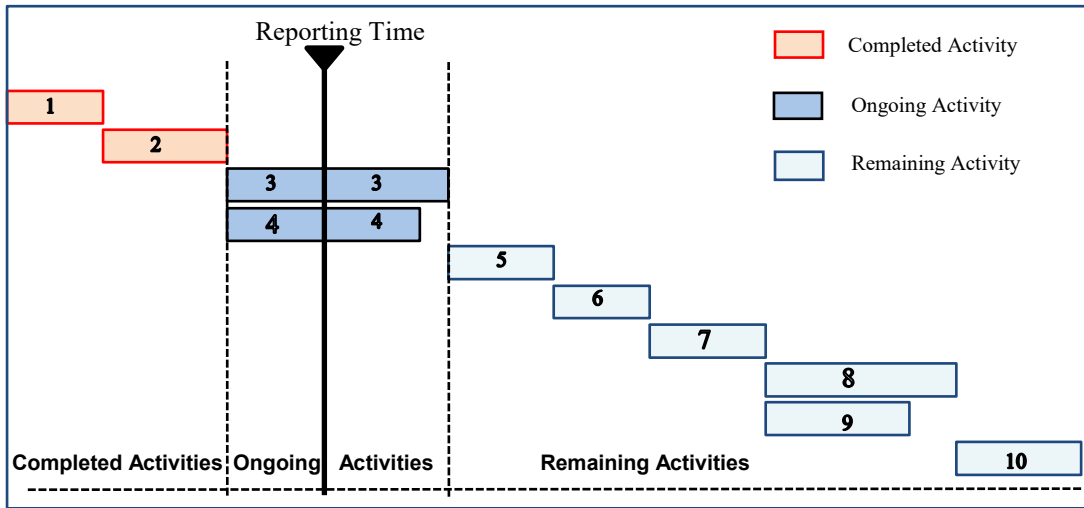

**Figure 4.17 Different Types of Activities During Construction**

**Remaining Activities:** These are activities that did not start yet and are planned to start in future dates. The same corrective action strategies can be applied to these activities and accordingly, their durations and cost can change depending on their revised methods of construction. Moreover, some activities could be added to or deleted from the project due to changes in scope by the owner. The proposed control framework enables the team to make informed decisions on what strategies should be followed to meet project constraints.

**On-Going Activities:** These are the activities that started but not yet completed. Corrective actions can be applied to these activities by changing their construction method ( $j$ ) to a faster construction method (e.g.,  $j+1$ ). As such, the remaining percentage of the activity (i.e.,  $1 - Pc_{ijk}$ ) will proceed at the daily rate of the ( $j+1$ ) method, which is  $(100/d_{i(j+1)k})$ , as follows:

$$Rd_{i(j+1)k} = \text{Round Up} [(1 - Pc_{ijk}) * 100 / (100/d_{i(j+1)k})] \quad (4.22)$$

Thus, the updated activity duration and cost become:

$$D_{ik} = Ad_{ijk} + Rd_{i(j+1)k} \quad (4.23)$$

$$C_{ik} = Ac_{ijk} + (c_{i(j+1)k} * Rd_{i(j+1)k} / d_{i(j+1)k}) \quad (4.24)$$

where  $c_{i(j+1)k}$  is the planned cost for the new corrective action method ( $j+1$ ).

To illustrate the possible corrective actions to on-going activities, consider an example activity that is planned to have three construction methods with different durations and costs as shown in Figure 4.18. The planned duration for the activity considered in the example is 6 days using construction Method 1 that costs \$120,000. The second and third construction Methods are faster and more expensive as shown on the top of Figure 4.18.

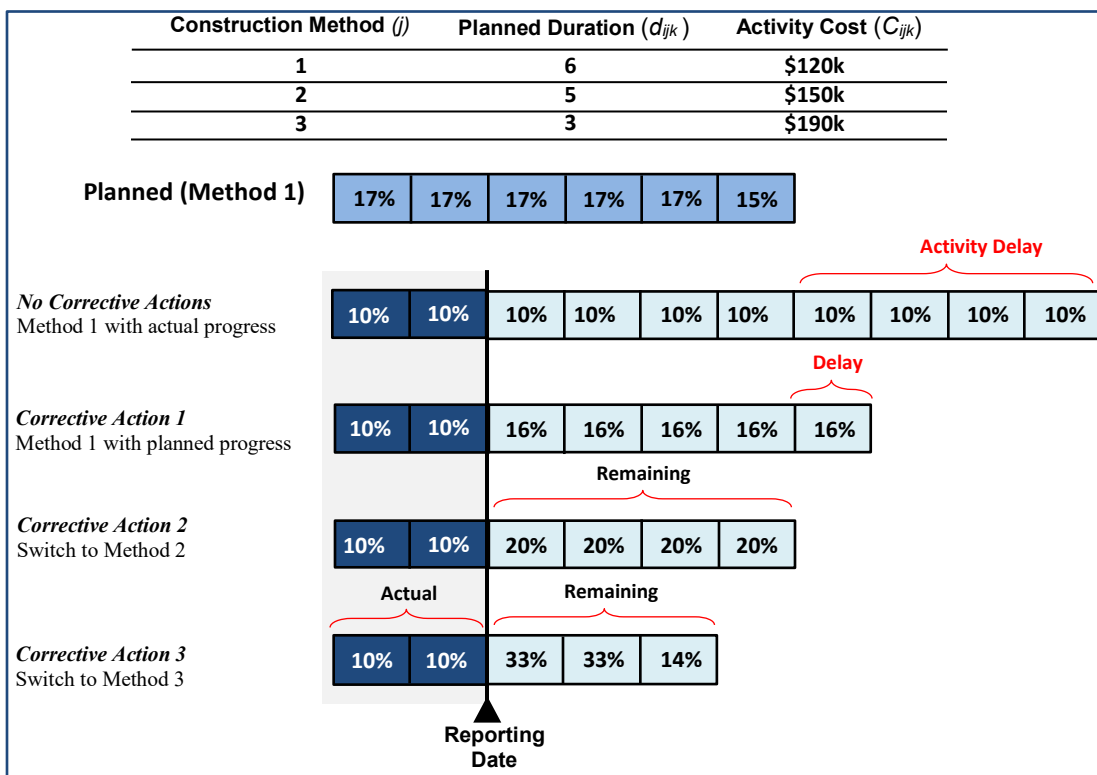

**Figure 4.18: Effects of Various Corrective-Action Decisions**

At a certain reporting date (after 2 units of time), only 20 % of the work is completed as opposed to the 33% planned progress. The actual direct cost reported to date is \$40,000. With

this information, the updated schedule for this activity and the effect of various corrective actions are as follows:

**No Corrective Action:** This strategy is basically to maintain the status quo. to continue using the same construction Method 1 and the remaining progress rate follows the actual progress rate for the first two days which is 10% as opposed to the 20% planned progress rate. Using Equation 4.18 and Equation 4.19 to calculate the updated duration and cost;

$$\textit{The Updated Activity Duration}(D_{ijk}) = 2 + \textit{RoundUp}2(1 - 0.2)/0.2] = 10 \textit{ days}$$

$$\textit{The Updated Activity Cost}(C_{ijk}) = \$40,000 + \$120,000 * 8/6 = \$200,000$$

The updated activity duration is 10 days which represent 4 days delay from the 6 days planned duration.

**Corrective Action 1:** This strategy is to continue using construction Method 1 and motivate the workers to follow the planned progress rate (17% per day). Using Equation 4.20 and Equation 4.21, the updated activity duration and cost become:

$$\textit{The Updated Activity Duration}(D_{ijk}) = 2 + \textit{RoundUp} 6(1 - 0.2) = 7 \textit{ days}$$

$$\textit{The Updated Activity Cost}(C_{ijk}) = \$40,000 + \$120,000 * 5/6 = \$140,000$$

The updated activity duration is 7 days (one day delay from the planned 6 days).

**Corrective Action 2:** This strategy is to change the current construction Method 1 to a faster construction Method 2 to recover the delay resulted from the slow progress at the first two days. Construction Method 2 has 5 days planned duration and %20 planned progress rate. Using Equation 4.22 to Equation 4.24 to calculate the remaining duration, updated duration, and updated and cost;

$$\textit{The Remaining Duration} Rd_{i(j+1)k} = \textit{RoundUp}(1 - 0.2) * 100/(100/5) = 4 \textit{ days}$$

*The Updated Activity Duration*  $(D_{ik}) = 2 + 4 = 6 \text{ days}$

*The Updated Activity Cost*  $(C_{ik}) = \$40,000 + \$150,000 * 4/5 = \$160,000$

The updated activity duration is 6 days (which recover the delay from the first two days and bring the activity duration to the original planned duration).

**Corrective Action 3:** This strategy is to change the current construction Method 1 to construction Method 3, which is the fastest construction method available to recover the delay resulted from the slow progress at the first two days and possibly create a schedule advantage. Construction Method 3 has 3 days planned duration and 33% planned progress rate. Using Equations 4.22, 4.23, and 4.24 to calculate the remaining duration, updated duration, and updated and cost;

*The Remaining Duration*  $Rd_{i(j+2)k} = RoundUp(1 - 0.2) * 100/(100/3) = 3 \text{ days}$

*The Updated Activity Duration*  $(D_{ik}) = 2 + 3 = 5 \text{ days}$

*The Updated Activity Cost*  $(C_{ik}) = \$40,000 + \$190,000 * 3/3 = \$230,000$

The updated activity duration is 3 days (which presents one day schedule advantage).

To illustrate the impact of corrective actions at the activity level on the project schedule, consider an example of three activities at three sites shown in Figure 4.19. At the reporting date, activity A was completed at all sites with various delays, activity B was partially completed at all sites, and activity C was not started at any site. No corrective actions would have resulted in a significant delay to activity A and the whole project. Corrective action one (the remaining to follow the planned progress rate) reduces the delay to activity B and the project. Corrective action 2 (to use construction Method 2) eliminates the delay for activity B but the project is still behind schedule. Corrective action 3 (to use construction Method 3) eliminates the project delay and bring the project back to the planned duration.

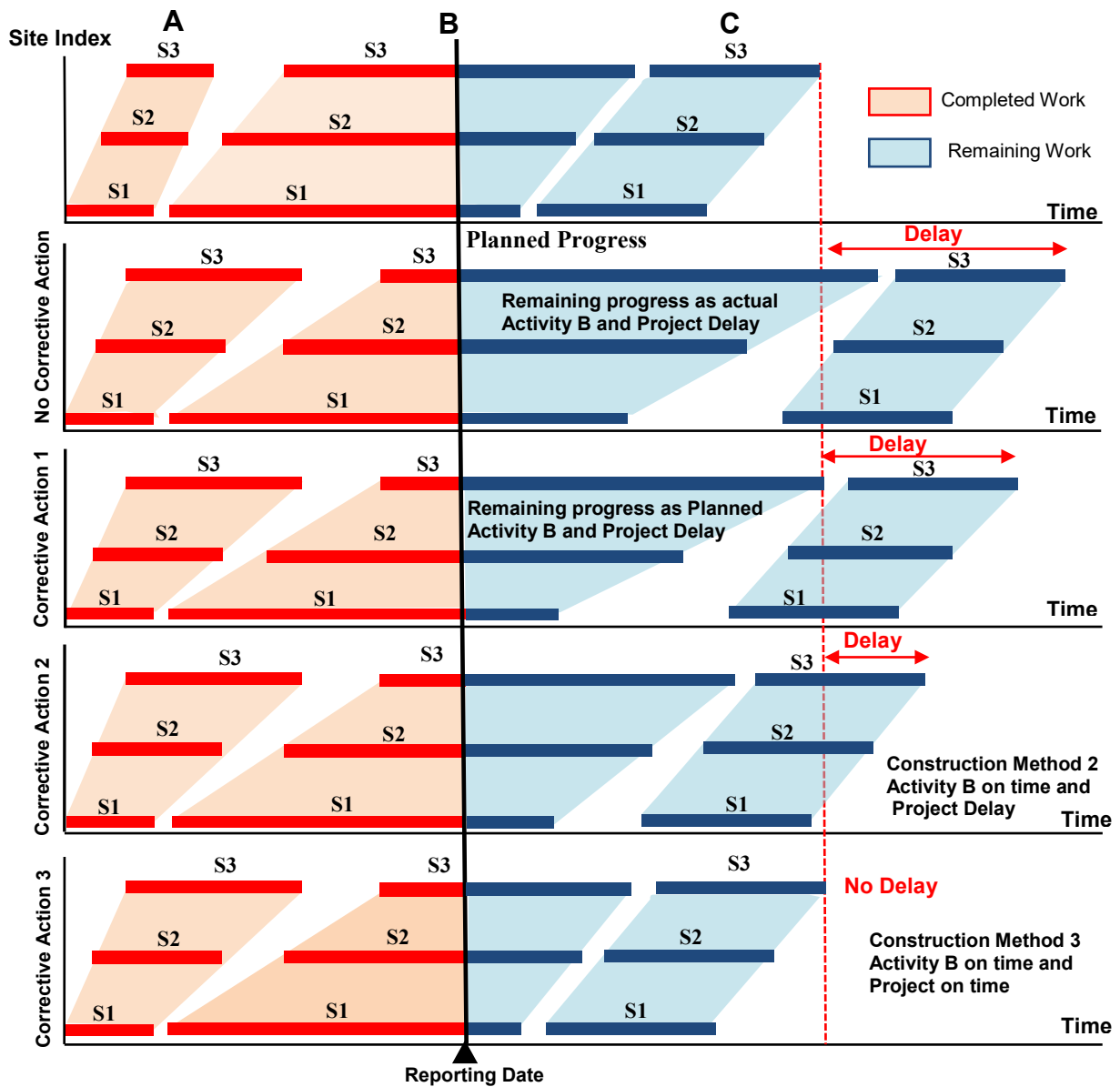

**Figure 4.19 Impact of Corrective Actions at The Activity Level on The Project Schedule**

Furthermore, the framework enables the project team to make corrective decisions on the project level to alleviate deviations from the original schedule. To illustrate that, consider an example of four activities at six scattered repetitive sites shown in Figure 4.20. At the reporting date, activity A was completed at all sites with various delays, activity B was partially completed at all sites, and activities C and D were not started at any site. No corrective actions would have resulted in a significant delay to the project. Corrective action One to re-optimize

the original identified optimum site execution order to incorporate the actual progress delays. This modified optimum site execution order reduces the project delay. Corrective action Two to introduce work interruption to activity C at site 5 allows activity D to start and finish earlier than planned, eliminates the project delay and brings the project back to the planned duration.

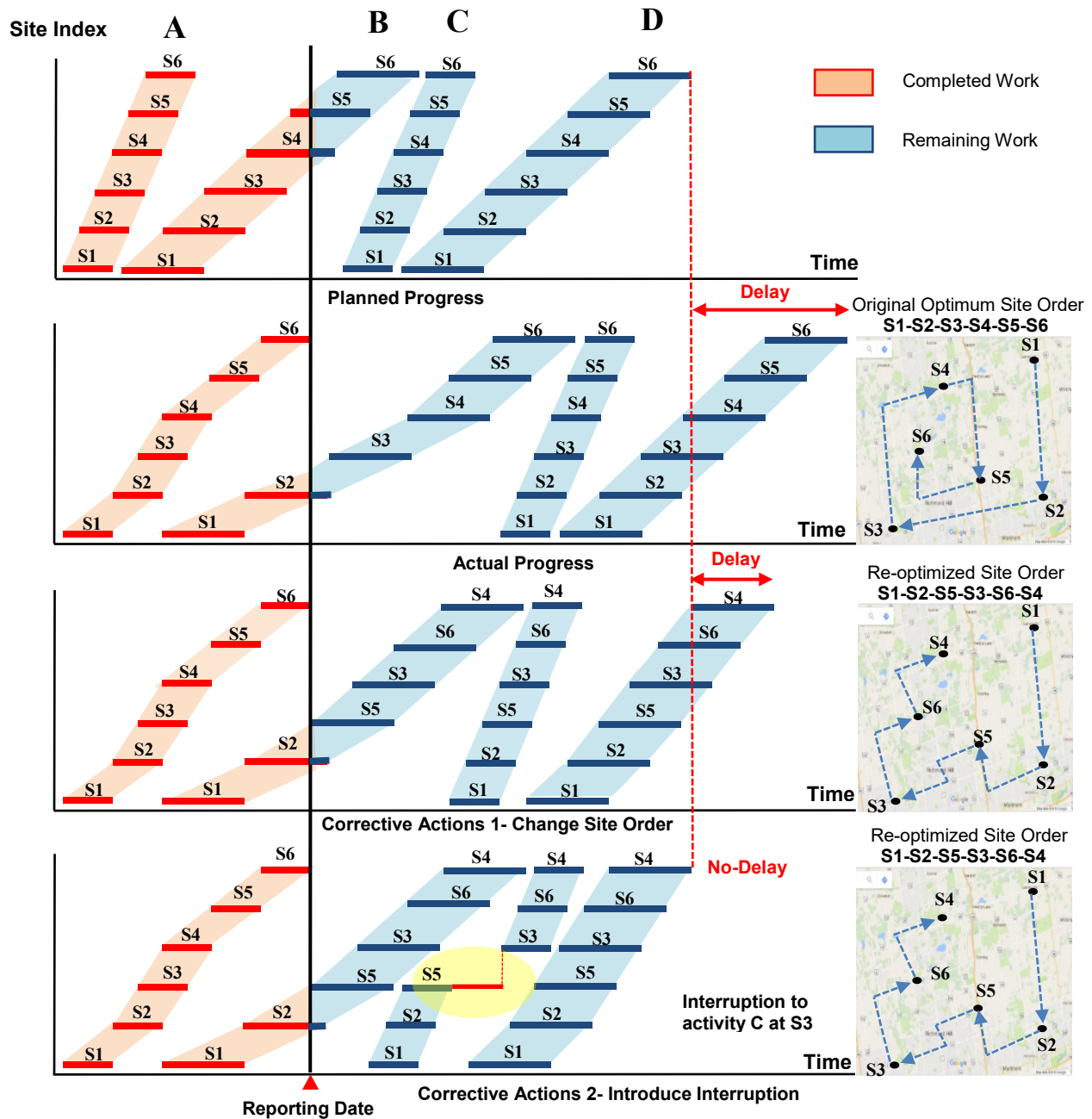

Figure 4.20: Corrective Actions at the Project Level

## 4.6 Cost and Schedule Optimization Model

To demonstrate the cost and schedule optimization model variables, constraints, and objectives, consider a scattered repetitive project with ( $S$ ) sites and ( $N$ ) activities, each activity ( $i$ ) has a number of possible construction methods ( $M_i$ ). Every method ( $j$ ) (from 1 to  $M_i$ ) represents a construction method to perform an activity ( $i$ ).

**Model Variables:** In the present model for scattered repetitive projects, there are four sets of variables (decisions) in the model:

- Activity Construction Method:**  $X_{ij}$  is a zero-one variable that represents which construction method ( $j$ ) is used for each activity ( $i$ ). If  $X_{ij} = 1$ , then the construction method ( $j$ ) will be used to perform activity ( $i$ ),  $X_{ij} = 0$  means the otherwise.
- Activity Crews:**  $Cr_{ia}$  is the number of crews to use for each activity ( $i$ ). As such a single matrix that represents the two variables (Activity Construction Method, and No. of Crews) for all activities can be represented as follows (Figure 4.21):

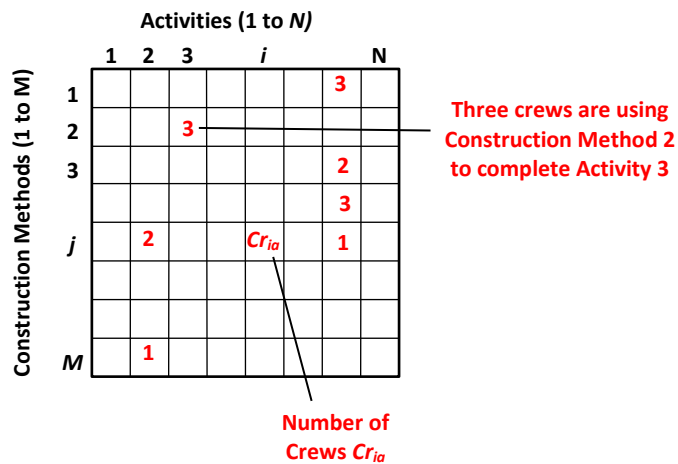

Figure 4.21: Construction Method and Number of Crews Variables

- c. **Designed Work Interruption:**  $I_{ik}$  is the interruption time for an activity ( $i$ ) at a site ( $k$ ) and this variable can be represented by the following matrix (Figure 4.22):

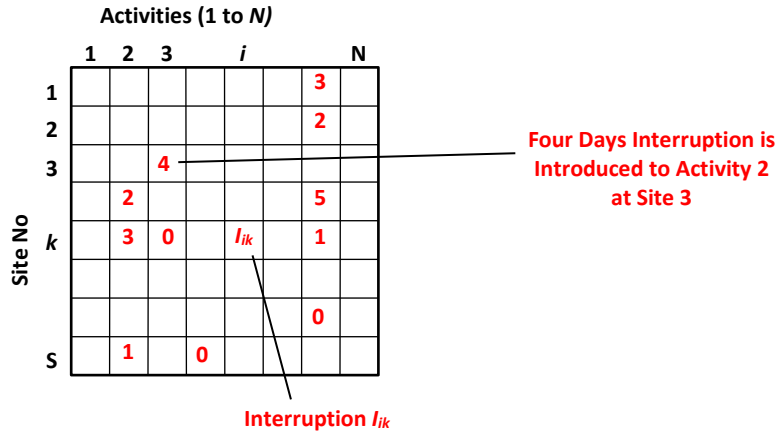

Figure 4.22: Work Interruption Variable Representation

- d. **Site Order:** Each activity ( $i$ ) has a variable site execution order, as represented in the following matrix (Figure 4.23):

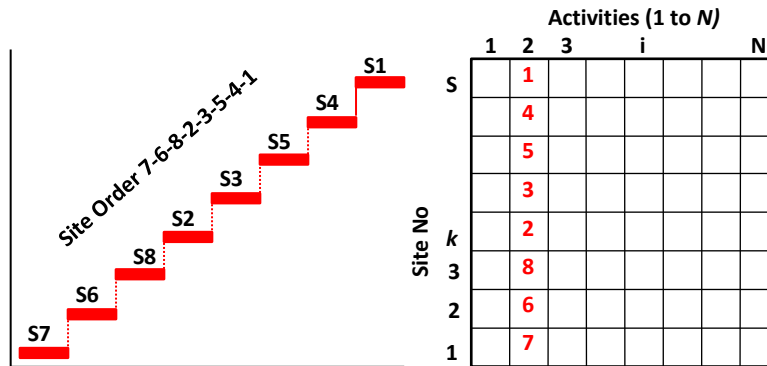

Figure 4.23: Site Order Variable Representation

Each construction method ( $j$ ) has a specific duration ( $d_{ij}$ ), cost ( $C_{ij}$ ) and resources ( $Cr_{ia}$ ). The planned duration ( $D_{ik}$ ) of a site ( $k$ ), and direct cost ( $C_{ik}$ ) of each activity ( $i$ ) are expressed as a function of which method is used, as follows:

$$D_{ik} = \sum_{j=1}^{M_i} d_{ijk} X_{ij} \quad (4.25)$$



$$C_{ik} = \sum_{j=1}^{M_i} c_{ijk} X_{ij} \quad (4.26)$$

Since only one method is used in the activity at a time, then the sum of the zero-one variables of all construction methods should be equal to 1 (Equation 4.27).

$$\sum_{j=1}^{m_i} X_{ij} = 1 \quad i = 1, 2, \dots, N \quad (4.27)$$

**Model Calculations:** Building on the above equations, the values of the model variables are used to perform project calculations, as follows:

The Total Project Cost (*TPC*) is the summation of the Project Direct Cost (*PDC*); the Project Indirect Cost (*PIC*); Penalties ( $C_p$ ) (if any); and Incentives ( $In$ ) (if any) as follows:

$$TPC = PDC + PIC + C_p + In \quad (4.28)$$

The Project Direct Cost (*PDC*) is the summation of the activities' direct costs as follows:

$$PDC = \sum_{i=1}^N C_{ik} = \sum_{i=1}^N \sum_{j=1}^{M_i} c_{ijk} X_{ij} \quad (4.29)$$

The Project Indirect Costs (*PIC*) is the summation of the fixed indirect costs  $IC_0$  that are not dependent on the project duration  $T$  such as the cost of permits, mobilization, temporary roads, hoarding, etc., and the indirect costs  $IC$  that are time dependent such as site offices rentals, mobile washrooms rentals, site personnel and management salaries. These costs are calculated as follows:

$$PIC = IC_0 + IC * T \quad (4.30)$$

Most construction contracts include liquidated damage and incentive clauses. If the project is not finished on time, the contractor must pay a certain penalty. If the project is completed before the completion date, the contractor is entitled to an incentive. To accommodate that, the model adjusts the total project cost to consider the penalty ( $C_p$ ) and the incentives ( $In$ ) amounts as follows:

$$C_p = C_{pd} * O * (T - \text{deadline duration}) \quad (4.31)$$

$$In = In_d * Q * (\text{deadline duration} - T) \quad (4.32)$$

where  $C_{pd}$  is the cost of delay per day,  $O$  is a binary that indicates if the delay occurred (i.e.,  $O = 1$  if the project duration  $T >$  deadline duration),  $In_d$  is the incentive per day,  $Q$  is a binary variable that indicates if the incentive is warranted (i.e.,  $Q = 1$  if project duration  $T <$  deadline duration).

**Model Objective Function:** The model objective is to minimize the total project cost considering all the project variables to meet all the project constraints as follows:

$$\text{Minimize } TPC = \text{Minimize } (PDC + PIC + C_p - In) \quad (4.33)$$

**Model Constraints:**

1. *Network Logic Constraints:* The logical relationship between any activity ( $i$ ) and its immediate successor ( $sc$ ), is expressed as:

$$ST_{sc} - FT_i \geq 0 \quad sc = 1, 2, \dots, NSC \quad (4.34)$$

where  $FT_i$  is the scheduled finish time of activity ( $i$ );  $ST_{sc}$  is the scheduled start time of the successor activity; and NSC is the number of immediate successors for activity  $i$ .

2. *Deadline Constraint:* The finish time of the ending activity  $FT_E$  must be less than the deadline duration as follow:

$$FT_E \leq \text{Deadline Duration} \quad E = 1, 2, \dots, NE \quad (4.35)$$

where  $FN_E$  is the finish time of ending activities, NE is the number of ending activities.

3. *Resource Constraints:* The actual number of crews  $Cr_{ia}$  used is less than or equal the number of maximum available crews as follows:

$$Cr_{ia} \leq \text{Maximum Available Crews} \quad (4.36)$$

## **4.7 Discussion and Summary**

This chapter has introduced the components of the proposed scheduling, control, and cost optimization framework for scattered repetitive projects. The framework consists of four main components; a) Integrated CPM/LOB; b) Practical Scheduling Constraints; c) Project Tracking and Control; and d) Cost and Schedule Optimization. Before construction, the framework determines the optimum combination of construction methods, number of crews, designed work interruption, and site execution orders to meet the project deadline. During the construction, the proposed framework uses the Critical Path Segment (CPS) technique to incorporate the daily site-events and reflect actual progress on the schedule to enable the project team to make informative corrective actions if the project deviates from the original plan.

To account for the scattered and complex nature of the infrastructure renewal projects, a new representation of the schedule is presented to improve the graphical representation and enable the optimization of the sequence of work for all crews. The new graphical representation considers the possible multiple site execution orders and represent the schedule in an easy to understand and communicate format. Next chapter presents computer prototype that is developed to automate the scheduling, control and cost optimization of scattered repetitive projects using Genetic Algorithms (GAs).

## **Chapter 5**

### **Model Implementation: A Case Study**

#### **5.1 Introduction**

A step-by-step implementation of the proposed scheduling and control framework for Scattered Repetitive projects (formulated in chapter 4) is presented in this chapter. To demonstrate the usefulness of the framework and illustrate its capabilities, a computer prototype system has been developed and tested on a case study of a real-life project that commonly takes place at school boards. The case study is to renovate seven science labs at seven different schools. The results of schedule optimization experiments are also presented.

#### **5.2 Case Study**

A typical project at universities and school boards is to convert spaces from one use to another, which is usually referred to as re-purposing. In the present case study, a project to reconfigure seven classrooms into seven labs at seven different schools at the School Board is considered. The network at each site is shown in Fig. 5.1 and involves ten construction activities, including demolition of the existing partitions, electrical and mechanical services, ceiling and flooring, erecting new partition walls, new electrical and mechanical services, new lab benching and casework, new ceiling, flooring, and painting. The activities, the logic of execution, the durations and the costs determined by the project team are listed in Table 5.1.

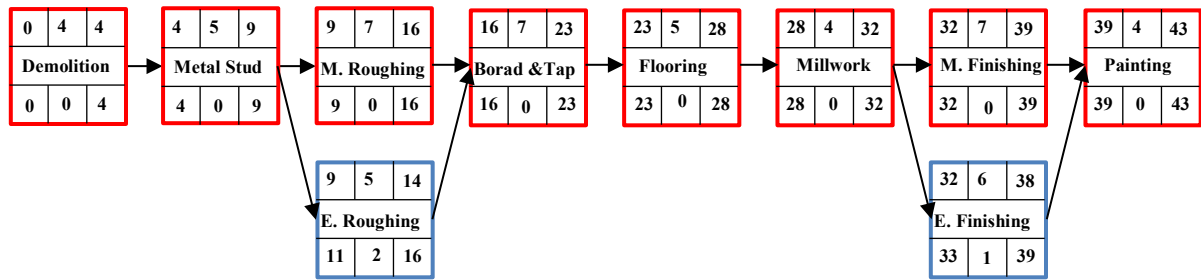

Figure 5.1: Case Study Activities Network

Table 5-1: Case Study Activities Details

Activity NO.	Description	Construction Method 1		Construction Method 2		Construction Method 3		Depends On	Max Crews No
		Cost (\$)	Dur. (Day)	Cost (\$)	Dur. (Day)	Cost (\$)	Dur. (Day)		
1	Demolition	\$15,000	4	\$17,000	3	\$20,000	2		3
2	Metal Stud	\$15,000	5	\$18,000	4	\$23,000	3	1	3
3	Mechanical Roughing	\$30,000	7	\$35,000	6	\$42,000	5	2	3
4	Electrical Roughing	\$20,000	5	\$23,000	4	\$27,000	3	2	3
5	Boarding and Taping	\$25,000	7	\$28,000	6	\$35,000	5	3,4	3
6	Flooring	\$15,000	5	\$18,000	4	\$23,000	3	5	3
7	Millwork	\$50,000	4	\$55,000	3	\$62,000	2	6	3
8	Mechanical Finishing	\$150,000	7	\$160,000	6	\$175,000	5	7	3
9	Electrical Finishing	\$100,000	6	\$110,000	5	\$130,000	4	7	3
10	Painting	\$15,000	4	\$18,000	3	\$22,000	2	8,9	3

During the planning stage, the following are several challenges and constraints that usually encounter project teams to execute projects at educational facilities on time and within budget:

- a) The project must be completed before the start of the school year. However, the work can't start earlier than end of June because construction activities would cause significant disruption to the school operation. Thus, as a compromise, it was decided that the construction can start earlier than end of June after the school hours, i.e., from 4pm to midnight. This would cost more as workers' productivity drops at night and workers are paid premium to work at night shift. Combined with strict safety and cleanliness requirements, the crews' productivity would be hindered by an estimated 20%. This will result in significant increase to the project duration and cost. The proposed model has sufficient flexibility that enables the project team to accommodate the operational needs of educational facilities' occupants by blocking sites (work is not

allowed) for specific period of time or during the business hours. Accommodating users' operational needs, however, usually result in reduction in working crew productivity and accordingly increase in the project cost and duration;

- b) The science departments at the renovated schools need to have the labs ready three weeks before the start of the academic year to allow teachers to prepare the new labs and start classes by the first week of September. This represents additional challenge to the project team to meet the project schedule and budget;
- c) The project indirect cost (costs that are not attributed to specific activities, such as salaries, etc.) is \$5,000 per day. The Liquidated Damages payable to the owner if the project is delayed is 10,000 per day. The Incentives payable to the general contractor if the work is completed earlier than the deadline is \$2,000 per day;
- d) Three alternative construction methods are identified for each activity with corresponding direct cost, crews, and durations. The first method (columns 3 and 4 in Table 5.1) is to employ regular sub-contractor who will work normal hours (8 hours./day). The second method (columns 5 and 6 in Table 5.1) is to pay the sub-contractor premium to work overtime (12 hours/day). This method will finish the activities faster than the first method ( i.e., shorter duration ), but will cost more. The third method (columns 7 and 8 in Table 5.1) is to use other expensive sub-contractor who has larger-size crews and more efficient machinery. This will finish the activities even faster than the previous methods, but will cost significantly more;
- e) The sizes of the remodeled rooms differ from one school to another. Accordingly, the amount of work for each activity is not identical and, therefore, the duration of these activities will differ from one site to another. Furthermore, some activities such as installing the VCT flooring doesn't exist at one site as the lab users at one school prefer to keep the concrete flooring as an architectural feature. These non-typical sites may affect the synchronization between crews among the sites. The variation in work amounts among the scattered sites is summarized in Table 5.2;

**Table 5-2: Typical and Non-Typical Sites**

Activity	Site#1	Site#2	Site#3	Site#4	Site#5	Site#6	Site#7
Demolition	100%	75%	125%	100%	50%	85%	75%
Metal Stud	100%	125%	150%	100%	75%	110%	50%
Mechanical Roughing	100%	75%	125%	100%	80%	70%	125%
Electrical Roughing	100%	75%	120%	100%	100%	50%	100
Boarding and Taping	100%	125%	150%	100%	75%	110%	50%
Flooring	100%	100%	125%	100%	0%	125%	100%
Millwork	100%	50%	100%	100%	75%	50%	125%
Mechanical Finishing	100%	75%	75%	100%	80%	70%	125%
Electrical Finishing	100%	75%	75%	100%	100%	50%	100%
Painting	100%	75%	50%	100%	85%	125%	50%

- f) The cost and duration of moving among sites are considered in calculating the duration and cost of the project. The model estimates that the moving time from one site to another will be one day if they are within 5 kilometers. This moving time encompasses the demobilization, loading and unloading equipment, and mobilization. It has some level of approximation to emphasize the impact of the moving time on the schedule; and
- g) While it is possible to use a combination of fast and slow subcontractors. The construction method selected for one activity may affect the selection of construction method for other activity. This was described in Section 4.4.3. and the correlated construction methods for the case study at hand is outlined in Table 5.3.

**Table 5-3: Conditional Construction Methods**

IF method	THEN use method
1 is selected for Metal Studs	1 or 2 for Board/Tape
3 is selected for Metal Studs	3 for Board/Tape
1 is selected for Mechanical Roughing	1 or 2 for Mechanical Finishes
3 is selected for Mechanical Roughing	3 for Mechanical Finishes
1 is selected for Electric Roughing	1 or 2 for Electric Finishes
3 is selected for Electric Roughing	3 for Electric Finishes

All-in-all, the above constraints on the case study project provide examples of practical situations encountered in many infrastructure rehabilitations scattered repetitive projects. The objective of the case study at hand is to demonstrate that the developed prototype is capable of considering all these practical constraints simultaneously, within a schedule that meets deadline in the least costly manner.

### **5.3 Framework Implementation: A Computer Prototype**

A prototype program has been developed using the VBA language of Microsoft Excel software and VB language. It incorporates a user-friendly interface to facilitate the automation of the infrastructure scattered repetitive projects scheduling and cost optimization framework functions. Some of the characteristics are:

- It works on a Microsoft Excel file to allow easy data entry;
- It specifies the number of scattered repetitive sites and their locations, maximum number of crews, desired deadline duration, correlated activities; and other constraints;
- It allows the project team to change the number of crews, method of construction, interruption times; and the site execution order for any activity to respect various project constraints;
- It calculates the moving costs and the durations of construction crews among the scattered sites using the GIS;
- It incorporates a GA optimization routine;
- It incorporates a color-coded liner scheduling chart to present the optimized schedule and its crews' movements; and
- It produces customized schedule diagrams to suit the needs of different management levels, i.e., Owner, General Contractor, and Sub-Contractors.

With the above characteristics, the prototype became ready for scattered repetitive projects. To apply the case study project, the steps in the following subsections were followed:



### 5.3.1 Project Calendar and Parameter

The first step is to enter the project calendar with the working days, weekends, and the state holidays, as shown in Figure 5.2. The project contractual obligations such as Liquidated Damages, Incentives, Fixed Indirect Cost, and Variable Indirect Cost are identified. The moving cost and time as a function of the distance a crew can move per day are also identified.

**Project: 7 school renovation project**  
 Brief Description: 7 school renovation project

Moving cost: 500 \$/KM , Speed: 5 KM/day

**Project Start:** 5/1/2017  
**Project Deadline (days):** 75  
**End date:** 2017/08/11

Penalty (\$/day): \$10,000  
 Incentive (\$/day): \$2,000  
 Fixed Indirects (\$): \$50,000  
 Variable Indirects (\$/day): \$5,000

Mon   
 Tue   
 Wed   
 Thu   
 Fri   
 Sat   
 Sun

**Holidays:**  
 7/3/2017  
 8/7/2017  
 5/15/2017

*Contractual obligations and other project parameters* (bracketed on the left)  
*Statutory Holidays* (bracketed on the right)

Figure 5.2: Project Calendar and Parameters

### 5.3.2 Activities of a Single Site

This step specifies the three possible construction methods for the project activities, each construction method has its duration and cost as shown in Figure 5.3. The three construction methods are used to optimize the schedule by speeding the construction to meet the deadline.

Dur. = 43		Unit Cost = \$435,000		Predecessors					Construction Method 1			Construction Method 2			Construction Method 3		
ID	Description	Dur	Cost	p1	p2	p3	SS	FF	Dur	Cost	Crew Limit	Dur	Cost	Crew Limit	Dur	Cost	Crew Limit
1	Demolition	4	\$15,000						4	\$15,000	3	3	\$17,000	3	2	\$20,000	3
2	Metal Stud	5	\$15,000	1					5	\$15,000	3	4	\$18,000	3	3	\$23,000	3
3	M. Roughing	7	\$30,000	2					7	\$30,000	3	6	\$35,000	3	5	\$42,000	3
4	E. Roughing	5	\$20,000	2					5	\$20,000	3	4	\$23,000	3	3	\$27,000	3
5	Boarding & Taping	7	\$25,000	3	4				7	\$25,000	3	6	\$28,000	3	5	\$35,000	3
6	Flooring	5	\$15,000	5					5	\$15,000	3	4	\$18,000	3	3	\$23,000	3
7	Millwork	4	\$50,000	6					4	\$50,000	3	3	\$55,000	3	2	\$62,000	3
8	M. Finishing	7	\$150,000	7					7	\$150,000	3	6	\$160,000	3	5	\$175,000	3
9	E. Finishing	6	\$100,000	7					6	\$100,000	3	5	\$110,000	3	4	\$130,000	3
10	Painting	4	\$15,000	8	9				4	\$15,000	3	3	\$18,000	3	2	\$22,000	3

Figure 5.3: Three Alternative Construction Methods for each Activity

### 5.3.3 Logical Relationships Between Activities

This step specifies the relationships between the activities such as Finish-To-Start (FS), Finish-to-Finish (FF), and Start-to-Start, as per the project network shown in Figure 5.1. For example, Mechanical Roughing and Boarding and Taping activities have Finish-To-Start (FS) relationship. Similarly, Electrical Roughing and the Boarding and Taping activities have Finish-to-Start (FS) relationship. Once all the activities, durations, costs, and relationships between activities are identified, the system calculates the critical path to determine each site network duration as a function of the activities methods used and identifies the critical activities (marked in red). In this case study, the duration of a single typical site using construction method 1 is 43 days.

### 5.3.4 Specifying the Scattered Sites

In this step, the locations of the scattered sites are specified by the physical address of each site. Accordingly, the system generates a map of all the sites (Figure 5.4) and calculates the distances between the sites along with the moving times and costs.

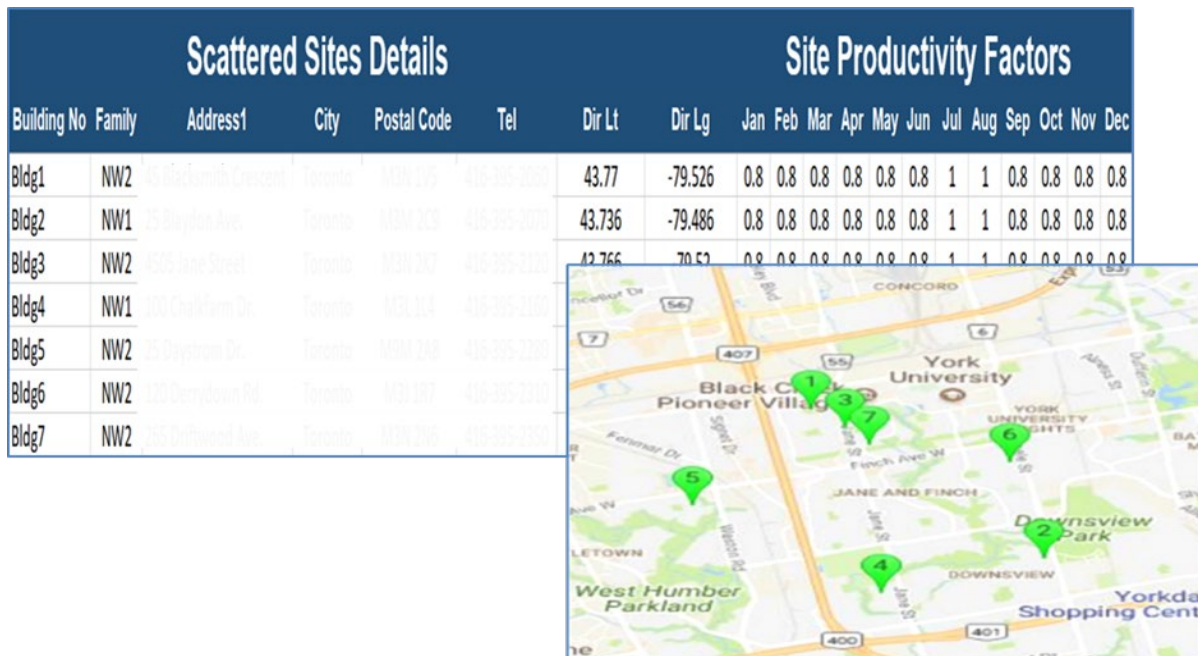

Figure 5.4: Locations of Scattered Sites and Productivity Factors

As shown in Figure 5.4, the prototype includes a productivity factor for every site at every month of the year to account for the impact of crews' productivity that combine several factors such as labor unrest; space congestion; interruption to occupied facilities; and unions' jurisdictions. For the case study at hand, working while the buildings being currently operational is the most important productivity factor considered. Therefore, a productivity factor of 0.8 (for May and June) at all sites is used as the construction crews are only allowed to work after hours and take extra care about safety and cleanliness. The productivity factor is also set as 1.0 (100%) for July and August where the schools are closed for the summer holidays and workers will work during regular working hours.

### 5.3.5 Practical Constraints

The next step is to specify the practical constraints that are commonly encountered by the project team that relate to the case study, as follows:

**Typical and Non-Typical Sites:** This step specifies the typical and non-typical sites. This is done by simply specifying the site's percentage of a typical site, as summarized earlier in Table 5.3. For example, Figure 5.5 shows that with respect to the Mechanical Roughing activity, building 4 (i.e., site 4) is a typical site (i.e., 100%) in terms of its time and cost.

The screenshot shows a software interface for configuring a task. At the top, the 'Task' dropdown is set to '3 M. Roughing'. Below this, there are fields for 'Task is from Unit: 1' and 'To Unit: 7'. The 'Typical Units' section displays a table of estimates for three methods:

Method	Duration (days)	Cost (\$)	Max. Crews	Selected Method
Method1:	7	30000	3	<input checked="" type="radio"/> 1
Method2:	6	35000	3	<input type="radio"/> 2
Method3:	5	42000	3	<input type="radio"/> 3

Below the table, the 'Special Units' section shows 'Bldg4' selected. A percentage field indicates 'This unit is 100% of typical.' A red box highlights the '100' value in the percentage field. Another red box highlights the '3 M. Roughing' task name. A third red box highlights the '100' value in the percentage field. A fourth red box highlights the '100' value in the percentage field.

Figure 5.5: Mechanical Roughing Activity Quantity (% of typical estimate) at Site 4

Figure 5.6a, on the other hand, shows that the Millwork activity at site 2 is a smaller non-typical activity with duration and cost that are only 50% of a typical site, while the same

Millwork activity at site 7 is a larger non-typical site with duration and cost are 125% of a typical site as shown in Figure 5.6b. Another type of non-typical activities is shown in Figure 5.6c (Flooring at site 5) where the activity is not required at this site.

Task  Millwork

Task is from Unit:  To Unit:

**Typical Units:**

Typical estimates for Task 7 (Table 5-1)

Method	Duration (days)	Cost (\$)	Max. Crews	Selected Method:
Method1:	4	50000	3	<input checked="" type="radio"/> 1
Method2:	3	55000	3	<input type="radio"/> 2
Method3:	2	62000	3	<input type="radio"/> 3

**Special Units:**

2

This unit is  % of typical.

**Task 7 in Site 2 is 50% (i.e., non-typical task) (Table 5-3)**

a. Non - Typical Site-Smaller Work Amount

Task  Millwork

Task is from Unit:  To Unit:

**Typical Units:**

Typical estimates for Task 7 (Table 5-1)

Method	Duration (days)	Cost (\$)	Max. Crews	Selected Method:
Method1:	4	50000	3	<input checked="" type="radio"/> 1
Method2:	3	55000	3	<input type="radio"/> 2
Method3:	2	62000	3	<input type="radio"/> 3

**Special Units:**

7

This unit is  % of typical.

**Task 7 in Site 7 is 125% (i.e., non-typical task) (Table 5-3)**

b. Non - Typical Site-Larger Work Amount

Task  Flooring

Task is from Unit:  To Unit:

**Typical Units:**

Typical estimates for Task 6 (Table 5-1)

Method	Duration (days)	Cost (\$)	Max. Crews	Selected Method:
Method1:	5	15000	3	<input checked="" type="radio"/> 1
Method2:	4	18000	3	<input type="radio"/> 2
Method3:	3	23000	3	<input type="radio"/> 3

**Special Units:**

5

**Task 6 in Site 5 is 0% (i.e., non-typical task) (Table 5-3)**

c. Non - Typical Site-Activity is not Available at this site

Figure 5.6: Activity Estimates at Non-Typical Sites

**Correlated Construction Methods:** In this step, the fifteen (15) correlated construction methods in Table 5.2 are specified. If construction Method 1 is used for Mechanical Roughing activity, either construction Method 1 (Figure 5.7a), or construction Method 2 (Figure 5.7b) is used for Mechanical Finishing activity. On the other hand, if the Mechanical Roughing activity uses construction Method 3, Mechanical Finishing follows and uses construction Method 3 (Figure 5.7c). This feature considers an important practical contractual obligation that is usually overlooked in the current scheduling practices.

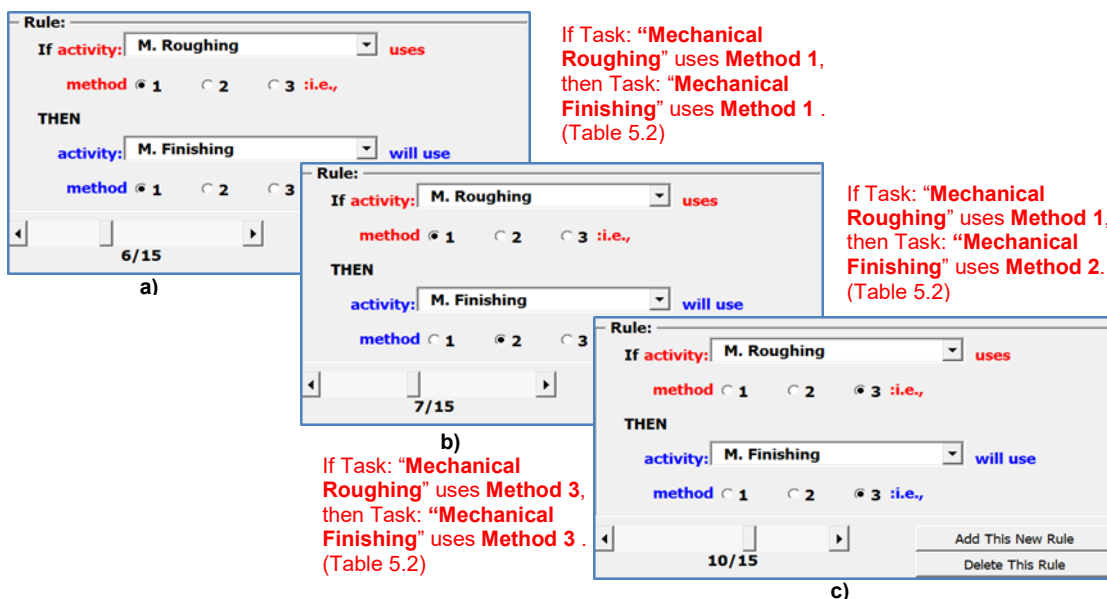

**Figure 5.7: Correlated Construction Methods**

### 5.3.6 Scheduling and Cost Calculations

Once the data entry is complete and all the constraints are specified, the model calculates the initial repetitive schedule and cost, as shown in Figure 5.8. The initial schedule results in project duration of 84 days which does not meet the required deadline (75 days) even before considering the time/cost of moving crews among sites or the impact of slower productivity during the month of May and June. It is noted also that all the activities follow the same initial 1-2-3-4-5-6-7 execution order.

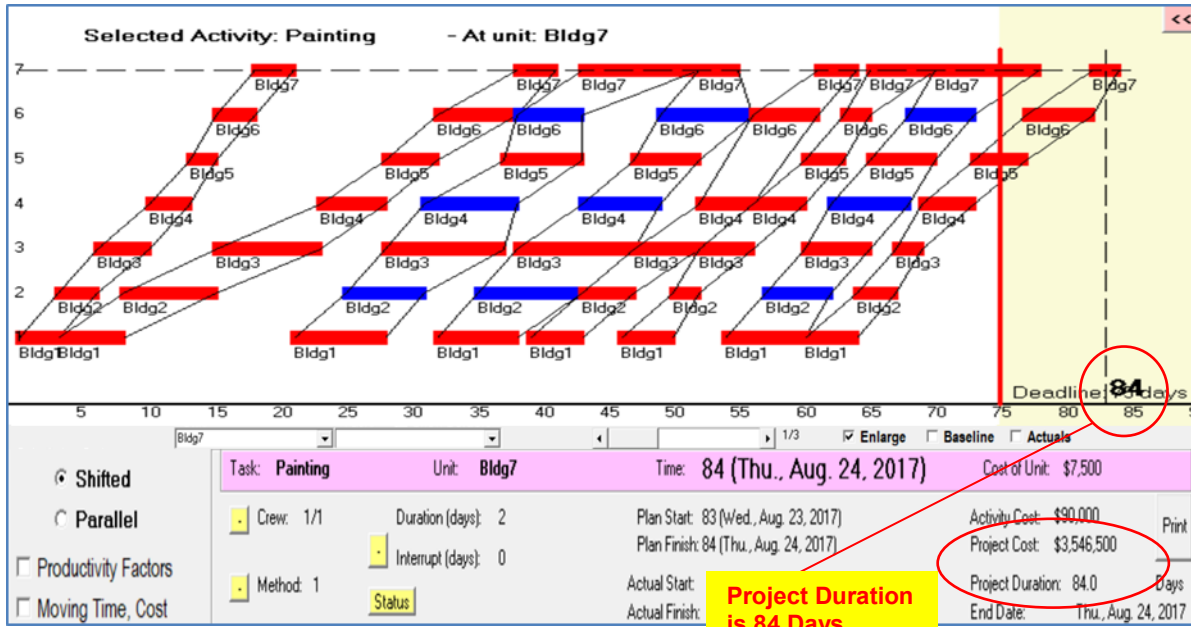

Figure 5.8: Initial Schedule without Productivity Factors or Moving Time/Cost

When “Productivity Factors” (Section 4.3.1 and Section 5.3.4) are considered, the project duration increased from 84 to 97 days and the project cost increased from \$3,546,500 to \$3,919,726 due to slower productivity in May and June as shown in Figure 5.9.

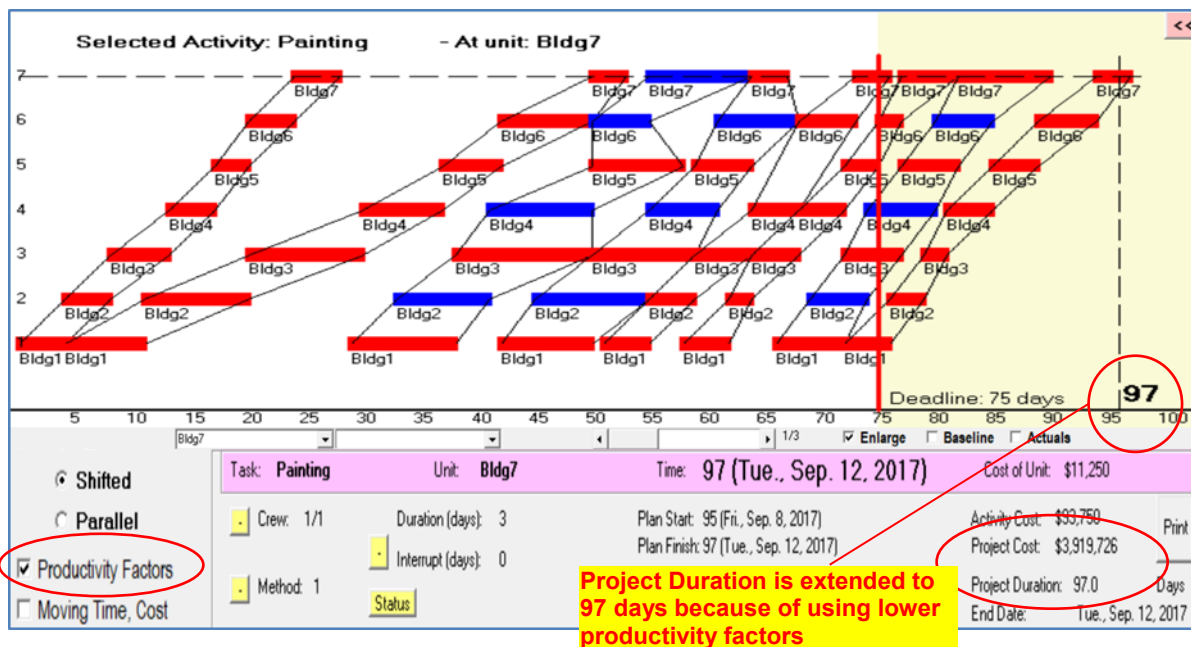
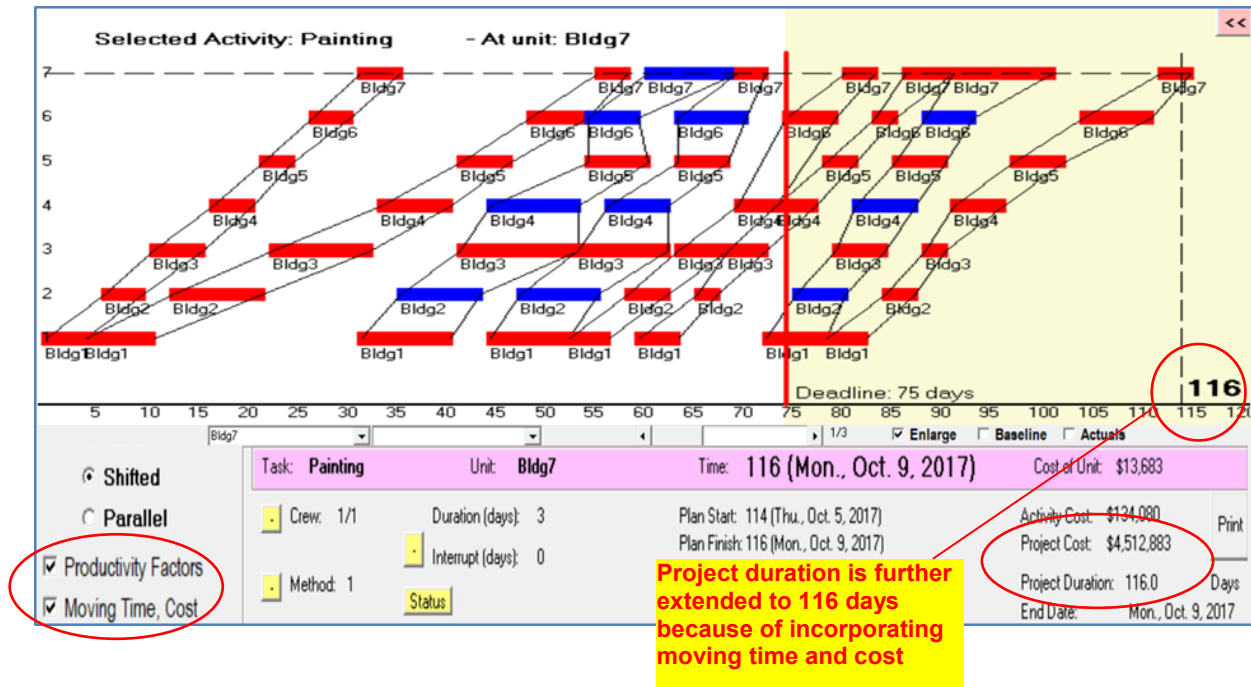

Figure 5.9: Impact of Productivity Factors on the Project Cost and Duration

When moving time and cost are considered (Section 4.4.5), the project duration increased from 97 to 116 days and the project cost increased from \$3,919,726 to \$4,512,883 as shown in Figure 5.10.



**Figure 5.10: Impact of Moving Cost and Time on the Project Cost and Duration**

This significant increases in the project duration and cost emphasizes the importance to determine an accurate productivity factors for each situation and consider these factors (described in section 4.3.1), as well as, the impact of moving time and cost of working crews among sites (described in section 4.4.5) Since the schedule does not meet the deadline constraint, the optimization feature becomes necessary. By activating this option, the optimization parameters are specified and the model searches for near-optimum solution. These options include: changing the number of crews; changing construction methods; changing execution site order; and introducing activity interruption time. As explained in section 4.6, the objective is to minimize the total project cost while meeting the project constraints.

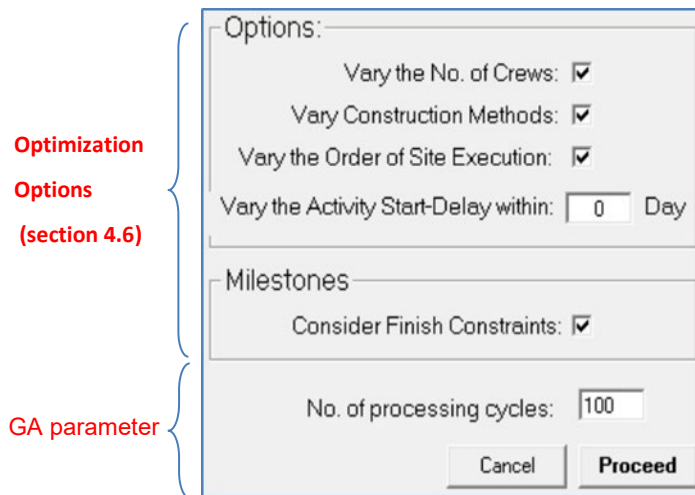

**Figure 5.11: Optimization Options**

Once the optimization options are entered, the prototype activates the GA evolutionary algorithm to search for the best schedule that satisfies all the above-mentioned conditions. The model determines the proper number of crews and the construction method for each activity, the proper designed interruption, and the proper site execution order that meet the project deadline while satisfies all the project constraints to minimize the total project cost.

Various experiemnts were conducted with different number of evolutionary cycles. From these initial experiemnts, 5,000 cycles were a good compromise between processing time of approximately 3 minutes and solution quality as more GA cycles did not reduce the cost further. Accordingly, 10 optimization experiemnts were conducted with 5,000 GA cycles and the best solution was considered to be the best near-optimum solution for this case study. The optimized duration of the project is 74 days which meets the project deadline of 75 days with associated total cost of \$3,799,306 as shown in Figure 5.12.

The key visualization enhancements of the proposed model that suits the specific needs of scattered projects includes the ability of the schedule to legibly show the following:

- activity duration and cost, and start / finish dates, similar to a bar chart;
- actual start and finish dates (this will be discussed in next section);



- color-coded crew assignment to each activity, with work continuity maintained;
- the construction method used in each activity and the planned interruption time; and
- the site execution order of the crews and the individual crew schedule using the enhanced visual discussed in section 4.4.4.

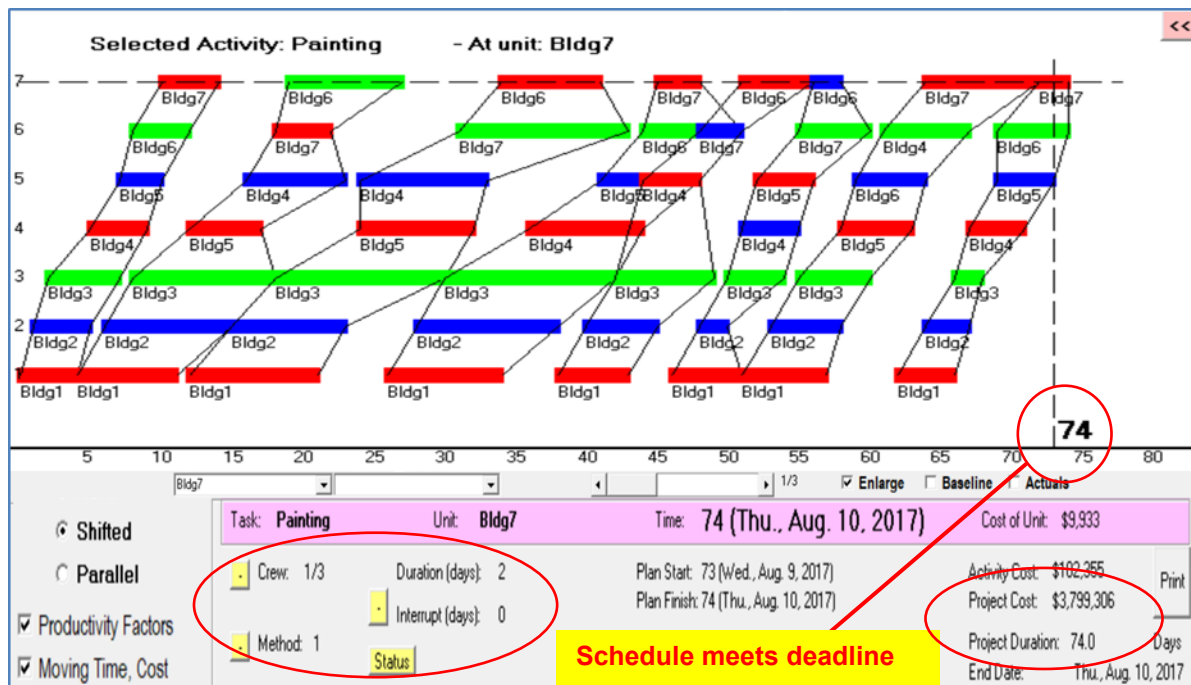

**Figure 5.12: Optimized Baseline Schedule that Meets Deadline**

For example, Figure 5.12 shows that crew 1 (marked in red) will take 2 days to complete the Painting activity at Building 7 utilizing construction Method 1. The planned start date is Wednesday August 9<sup>th</sup> 2017, which is the 73<sup>rd</sup> day of the project, and the planned finish date is Thursday August 10<sup>th</sup>, 2017, which is the 74<sup>th</sup> day of the project. The cost of the Painting activity at this site is \$9,933 including the moving cost from site 4 to site 7. Such comprehensive information provides the project team with the required data to make informative decision and take corrective measures should the project deviates from the planned schedule.

To make the schedule easy to communicate among the project parties, the model displays the modified LOB diagram of each individual path using color filled lines to show the movement of crews among scattered sites. For example, Figure 5.12 shows the LOB diagram using path 1, while Figure 5.13a shows the LOB diagram using path 2 and Figure 5.13b shows the LOB diagram uses path 3. This representation helps to avoid the schedule becoming cluttered and represent the schedule for scattered repetitive projects in legible and easy to understand format.

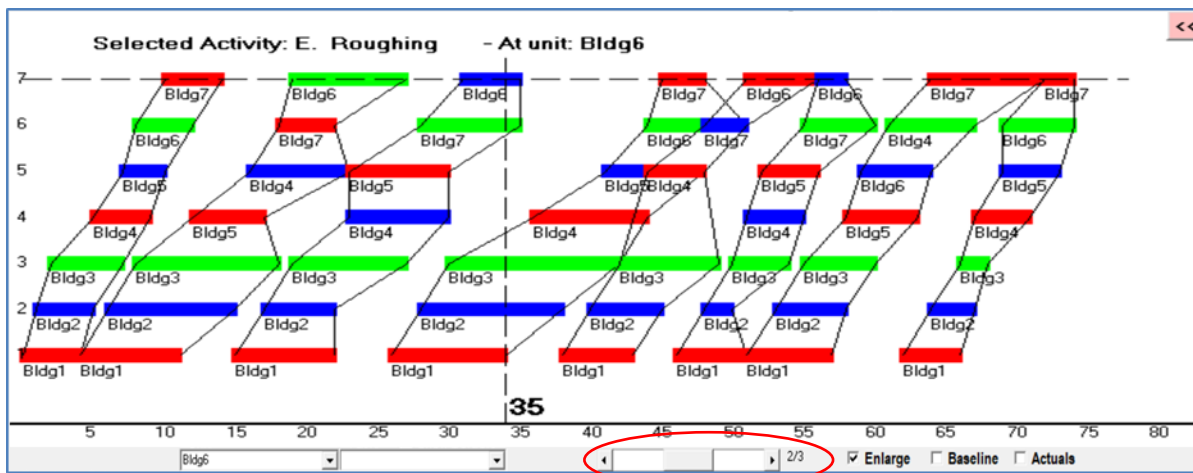

a) LOB Diagram-Path 2

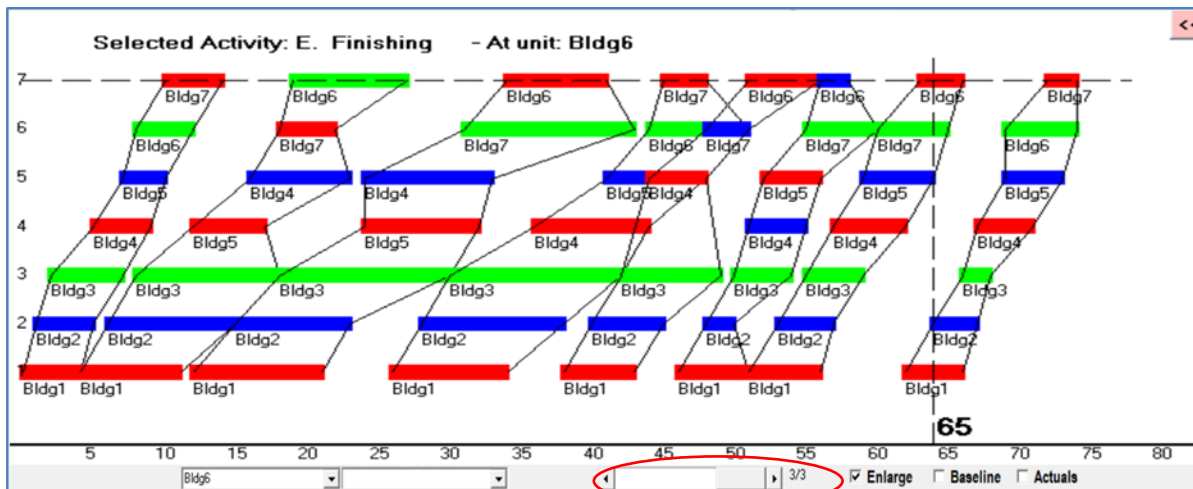

b) LOB Diagram-Path 3

Figure 5.13: LOB Diagram Representation with different Paths

The model produces customized LOB diagrams for each activity. Figure 5.14a shows the start and finish dates for Boarding and Taping activity at each site, the crews assigned to each site and the site execution order for this particular activity. Furthermore, the model produces a separate LOB not only for each sub-contractor, but also for each crew separately. Figure 5.14b shows the sites that are assigned to each crew for Boarding and Taping activity with the planned start and finish dates for each crew at each site. The figure shows the movement of crew 1 (marked in red) from site 1 to site 4 to site 7 while crew 2 (marked in blue) moves from site 2 to site 5. Crew 3 (marked in green) was first assigned to site 3 and then moves to site 6.

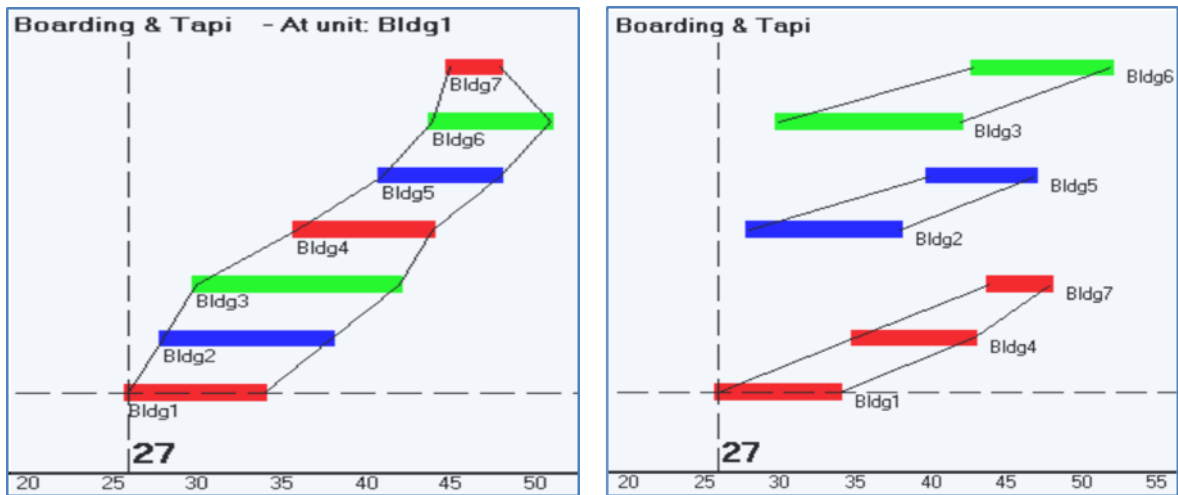

a) Typical LOB Schedule

b) New Representation of each Crew

**Figure 5.14: LOB Diagram Representation for Individual Activities and Crews**

Tailoring the schedule information to suit the needs of each sub-contractor enhances the ability of the project team to communicate effectively. While each sub-contractor is aware of the overall project schedule, they will be also able to focus on their own schedule and efficiently monitor the progress of their own forces.

### 5.3.7 Framework Verification

In this section, different aspects of the proposed framework described in chapter 4 are verified to ensure accuracy and consistency of the results. This includes:

1. Typical and Non-Typical Activities Durations and Costs (Section 4.3.1 and 4.4.2)
2. Correlated Construction Methods (Section 4.4.3)
3. Crew Assignment Strategies – First Come- First Served (Section 4.4.6); and
4. Activity specific site execution orders (Section 4.4.4).

**Activities Durations and Costs:** The model calculates the duration and cost of each activity considering various work quantities (typical-vs. non-typical) and various productivity factors. To illustrate the accuracy of the model calculations, two activities performing under various conditions are considered:

- **Typical Activity with Lower Productivity Factor:** Mechanical Roughing activity at site1 uses construction method 1, and the productivity factor is 0.8 (Figure 5.15).

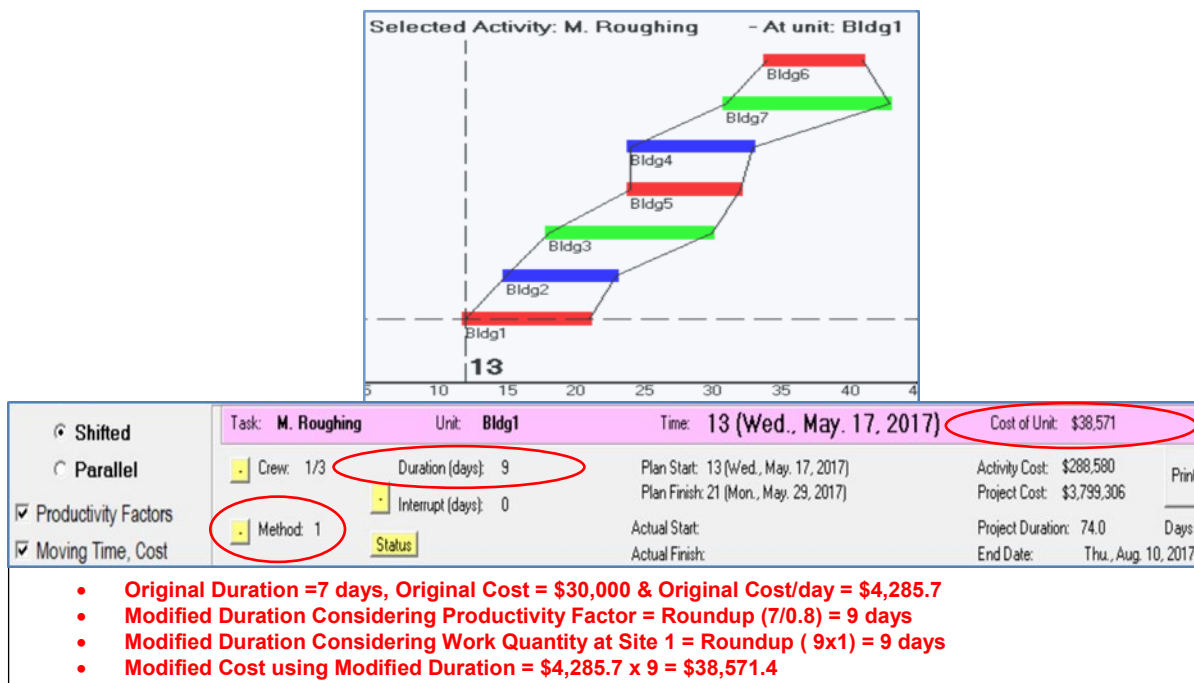
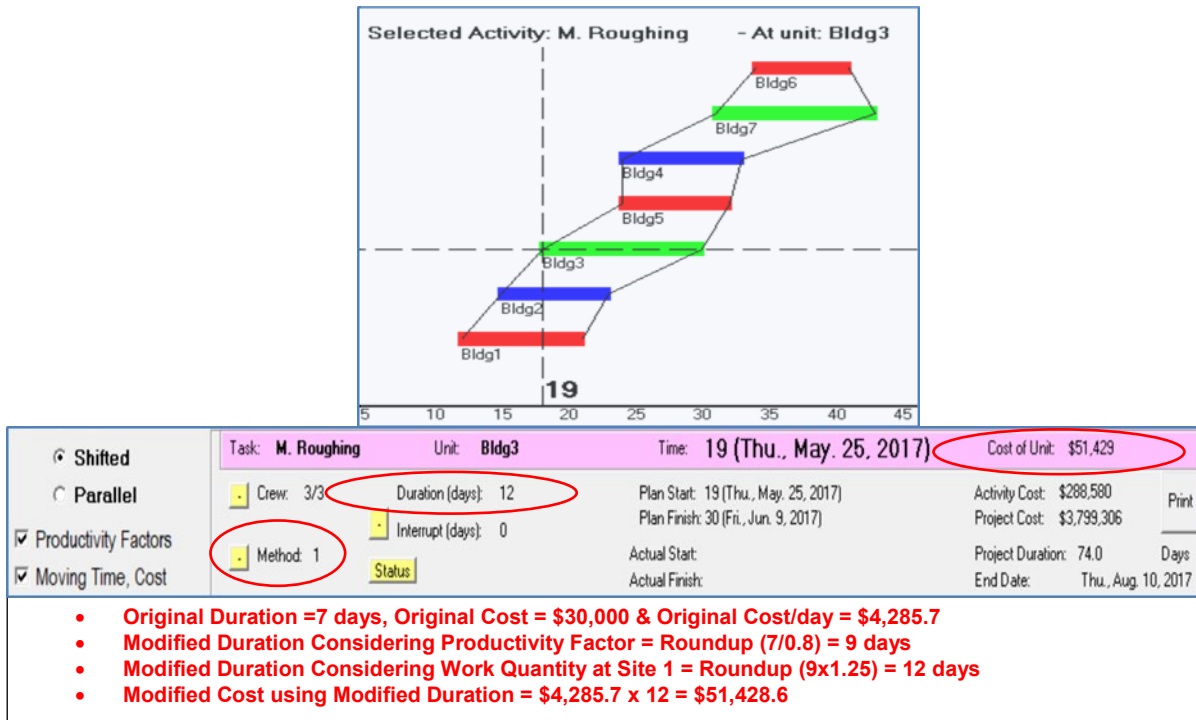

Figure 5.15: Duration and Cost Calculations for Typical Activity

- **Non-Typical Activity with Lower Productivity Factor:** Mechanical Roughing activity at site 3 uses construction method 1, work quantity is 125% of typical Mechanical Roughing, and productivity factor is 0.8 (Figure 5.16).



**Figure 5.16: Duration and Cost Calculations for Non-Typical Activity**

**Crews Assignment Strategy: First Come-First Serve (Section 4.4.6):** An important feature of the proposed model is assigning sites to the first available crew as opposed to the traditional sequential assignment to address the challenges of different work amount among sites, various productivity factors, and site execution orders. This is similar to First Come - First Served in manufacturing at the assembly line. Figure 5.17 shows crew1 (marked in red) is assigned to site 7 immediately after the crew finishes site 5 because crew 3 (marked in green) is still busy completing the work at site 3.

Crew 1 (marked in red) is assigned to Site 7 immediately after completing work at site 5 while crew 3 (marked in green) was still busy at site 3

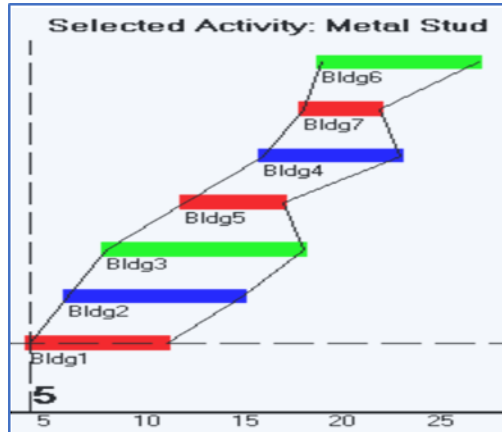

Figure 5.17: First Come First Serve Crews Assignment Strategy

**Correlated Construction Methods (Section 4.4.3):** The correlated methods identified for this case study in Table 5.2 are implemented in the model. For example, Metal Stud activity uses construction method 1 as shown in Figure 5.18a. Since the Boarding and Taping activity is performed by the same sub-contractor, it can only use either construction method 1 or 2. Construction method 2 was selected as shown in Figure 5.18b.

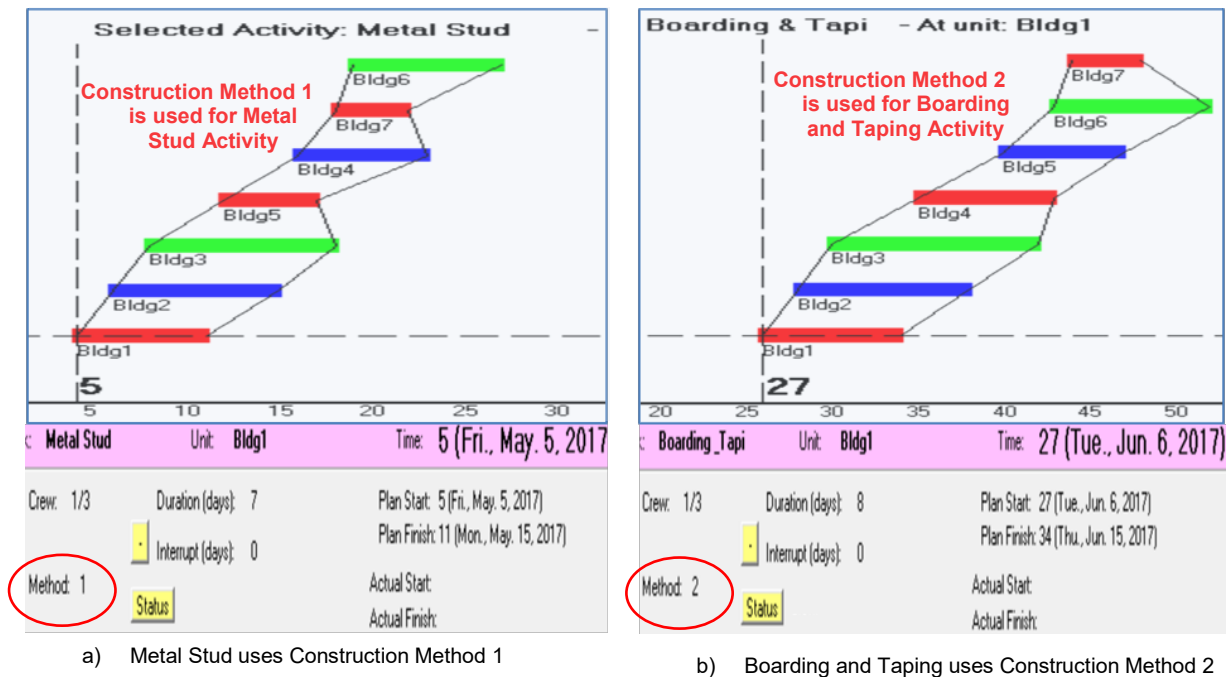
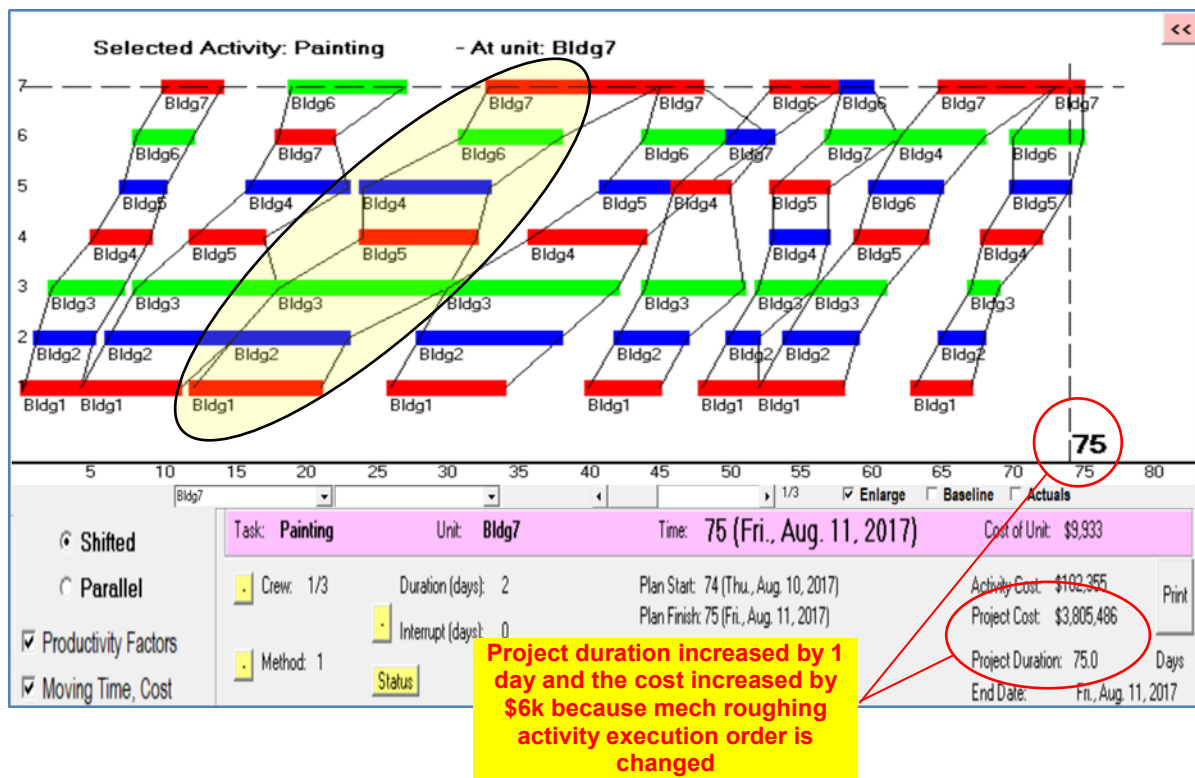

Figure 5.18: Correlated Construction Methods: Metal Stud & Boarding and Taping Activities

**Site Execution Order:** At the core of the proposed model is to vary the site execution orders to optimize the resources allocations. Furthermore, the model considers specific independent site execution order for each activity (Discussed in Section 4.4.4). This provides significant flexibility to project teams to assign their resources effectively. By changing the execution order of any activity from one site to another, the total construction cost and duration changes as the moving time and cost varies from one site to another. For Example, changing the site order of Mechanical Roughing activity from site execution order 1-2-3-5-4-7-6 to site execution order 1-2-3-5-4-6-7 extended the project duration by one day with additional \$6,000 cost as shown in Figure 5.20.



**Figure 5.19: Impact of Changing Activity Site Order on Cost and Duration**

## 5.4 Project Control

Once the optimized baseline schedule is established, the project team moves to the construction phase of the project. The baseline duration is 74 days and the baseline cost is \$3,799,306. The project team updates the actual progress and actual cost for each activity daily under the expectation that the remaining progress follows the planned progress. To illustrate the control features of the developed framework, two scenarios were considered:

1. The project follows the baseline (i.e., no corrective actions are needed)
2. The project is experiencing delays (i.e., corrective actions are needed)

**First Scenario:** the project follows the baseline schedule. At the end of day three, the Demolition activity has started at Building 1, 2 and 3. As discussed in section 4.5.1, the CPS divides each repetitive activity into daily time segments with actual and expected durations are presented on the schedule as shown in Figure 5.20.

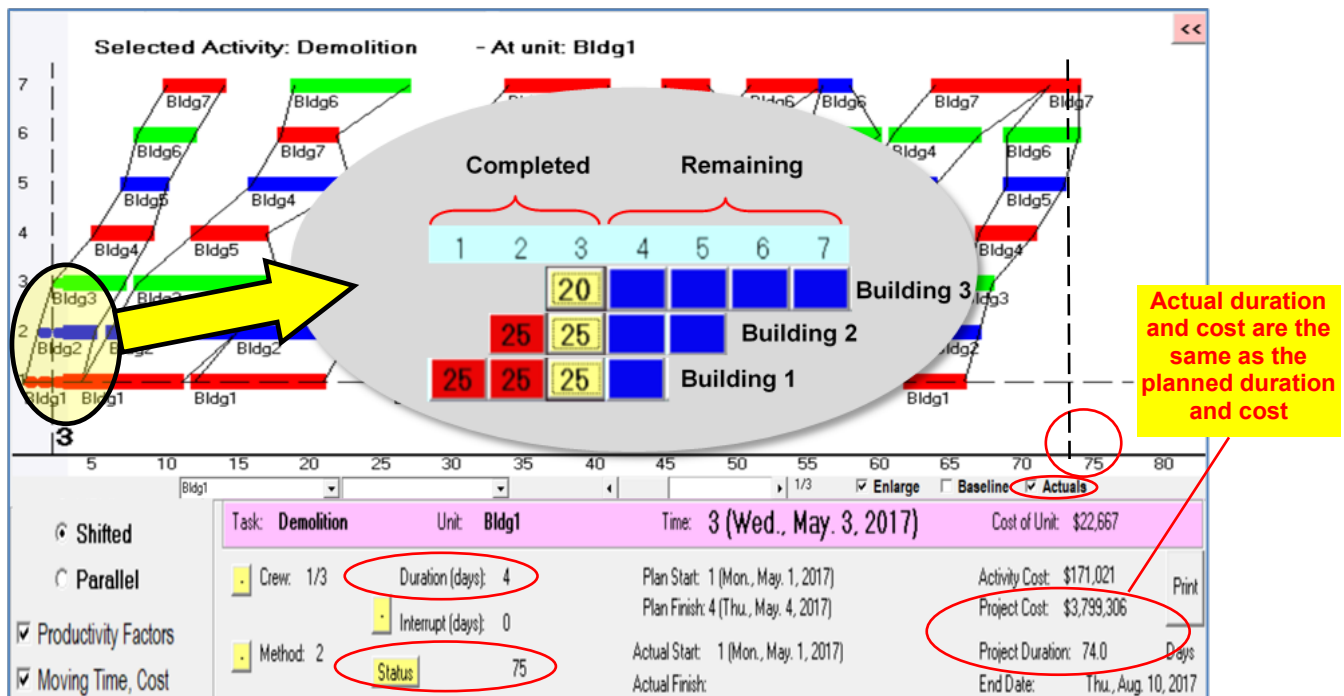
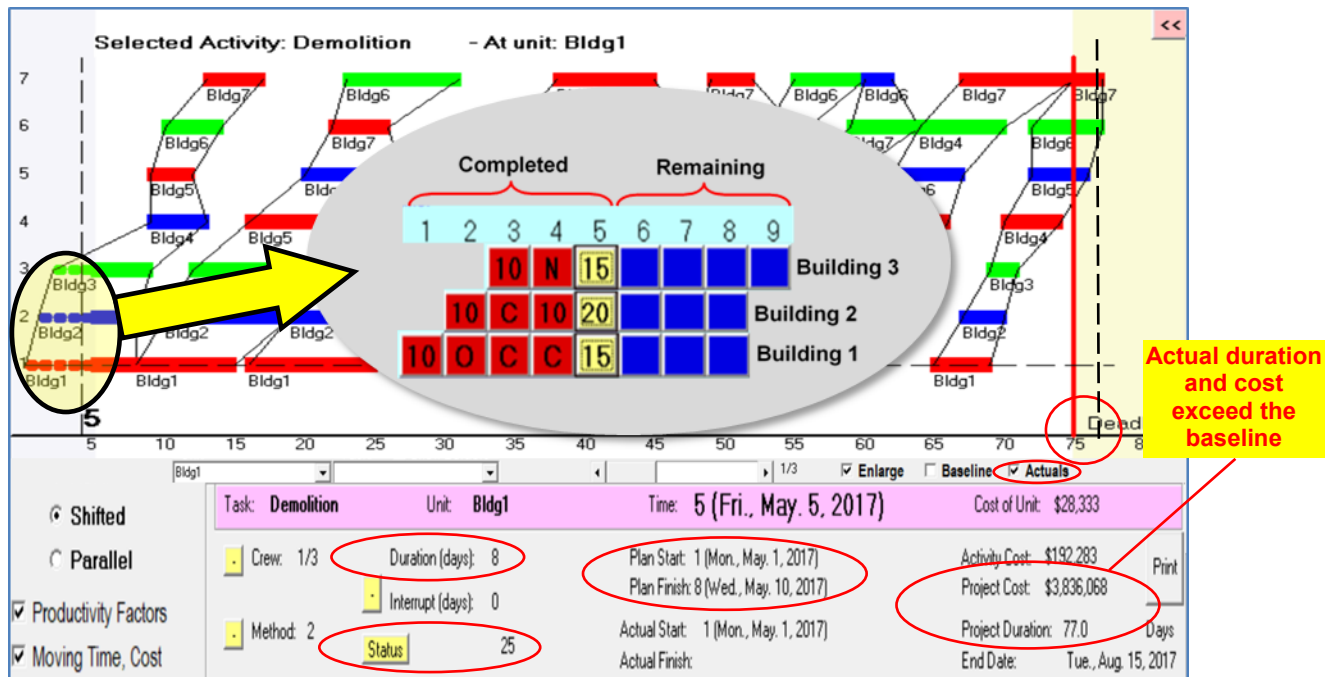

**Figure 5.20: First Scenario: The Actual Progress Follows the Baseline Plan**



It is noted that the updated duration and cost are the same duration and cost of the baseline schedule as the progress to date follows the planned progress rates, and therefore, the baseline schedule stays the same and no correction actions are required as shown in Figure 5.20.

**Second Scenario:** the project is experiencing delays and deviations from the baseline schedule. At the end of the first week, the Demolition activity has started at Building1, 2, and 3 with delays for various reasons as shown in Figure 5.21. It is noted that the model records the daily site events with parties responsible for delays. For example, the owner was responsible for the delay at building 1 on Day 2, while the contractor was responsible for the delay at building 2 on Day 3. The project duration is 2 days behind the deadline, and the total project cost is \$36,762 above the original project cost. Corrective actions are required to bring the project back on schedule, and the optimization becomes necessary.



**Figure 5.21: Second Scenario: The Project is Behind Schedule**

**Corrective Actions:** The model uses a combination of varying the site execution order and selecting other construction methods utilizing the optimization routine to update the schedule to meet the deadline with minimum cost. Several experiments were conducted using 5000 processing cycles and the solution with the lowest cost was deemed the near optimum corrective action plan (shown in Figure 5.22)

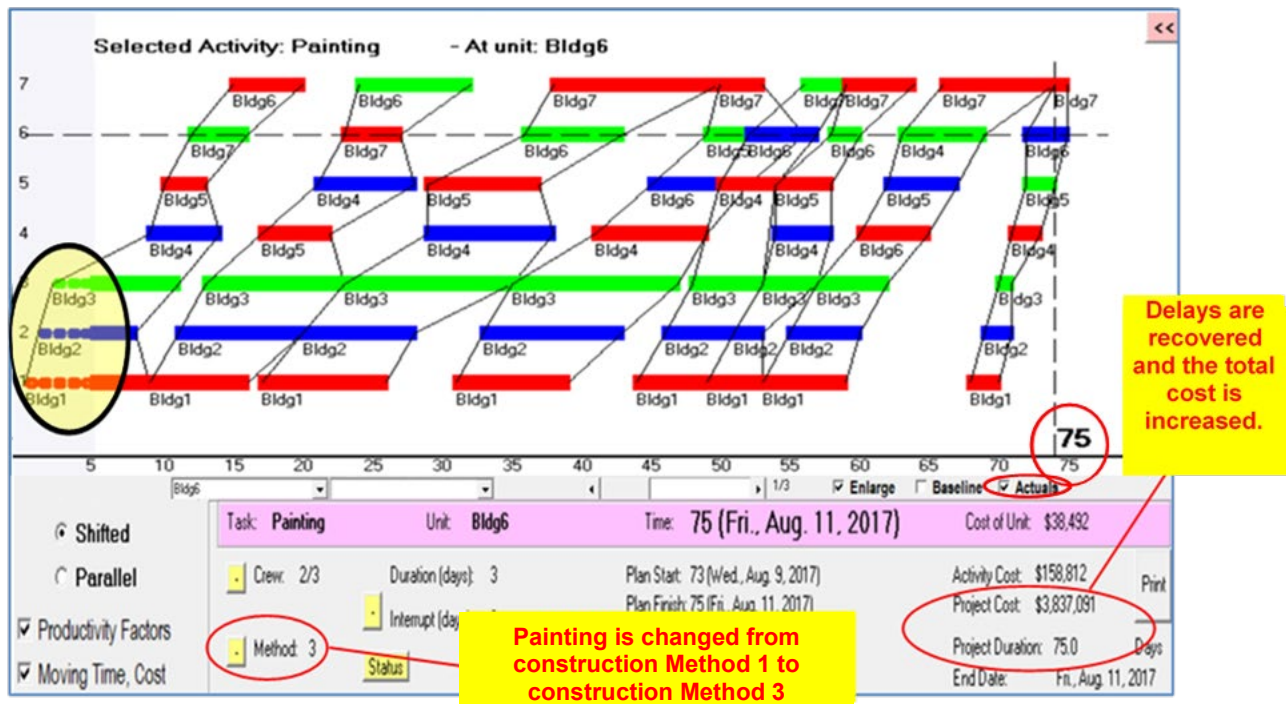

**Figure 5.22: Implemented Corrective Actions to Recover Schedule Delays**

The solution in Figure 5.22 shows the model uses two corrective actions:

**1. Changes the site executions order for some activities to improve the schedule as follows:**

- The execution site order for the Demolition activity changed from site 1-2-3-4-5-6-7 to site 1-2-3-4-5-7-6.
- The site execution order for the Metal Stud activity stays the same as site 1-2-3-5-4-7-6.

- The execution site order for the Mechanical Roughing activity changed from site 1-2-3-5-4-7-6 to site 1-2-3-4-5-6-7.
- The execution site order for the Electrical Roughing activity changed from site to site 1-2-3-4-5-7-6 to site 1-2-3-5-4-7-6.
- The execution site order for the Boarding and Taping activity changed from site 1-2-3-4-5-6-7 to site 1-2-3-4-6-5-7.
- The execution site order for the Flooring activity changed from site 1-2-3-4-7-6 to site 1-2-3-4-6-7. (Please note that Flooring activity is not available at site 5)
- The execution site order for the Millwork activity changed from site 1-2-3-4-5-7-6 to site 1-2-3-4-5-6-7.
- The execution site order for the Mechanical Finishing activity changed from site 1-2-3-4-5-6-7-4 to site 1-2-3-6-5-4-7.
- The execution site order for the Electrical Finishing activity changed from site 1-2-3-4-5-7-6 to site 1-2-3-4-5-7-6
- The execution site order for the Painting activity stays the same as the original execution site order which is site 1-2-3-4-5-6-7-4.

2. **Changes the construction methods for some activities to faster construction methods to recover some delays.** For example, the Painting uses construction Method 3 as opposed to construction Method 1 in the baseline schedule.

The model was able to recover the project delays with least possible additional costs within reasonable processing time (less than 3 minutes). This provides the project team with an effective tool to determine and implement corrective measures to bring projects back to the original baseline plan. To realize the full potential and benefit of the proposed model, the following aspects of the model should be noted:

- 1) The accuracy of progress tracking information is essential to ensure the developed corrective actions are realistic and effective to recover delays in most efficient manner. This is even more critical in infrastructure scattered repetitive projects due to their multi-location nature. This study introduces modified delivery method (discussed in detail in Chapter 6) that proposes to use one construction manager for each group of scattered projects to better control the quality of project progress tracking information and provide reasonable level of consistency.
- 2) Unforeseen conditions that negatively impact the construction schedule and cost are common in infrastructure rehabilitation projects. This is because most of these facilities are old and as-built drawings are not reliable and do not accurately reflect the actual condition of existing building components. In addition, the ability to conduct thorough investigation during the design phase is limited to avoid interrupting the facility operation. Thus, the lack of accurate as-built drawings combined with insufficient site investigations result in drawings that expose the project team to lengthy and expensive change orders. These changes in cost and durations are simulated in the proposed model by allowing the project team to alter the percentage of work quantity for activities at sites where these changes take place to calculate the impact of these changes on the final cost and duration.
- 3) The efforts to collect actual progress data are comparable to the current industry practices when good project control measures are in place. Combining each group of scattered projects in one project under the control of one constructor (as proposed in Chapter 6) would facilitate more effective progress data collection from scattered sites over large geographical area. The frequency of optimizing the schedule will vary from one project to another based on the size and duration of the project. Shorter duration projects will require more frequent project updates than longer duration projects.
- 4) The proposed optimization system applies more effectively when the user has full control over the resources engaged in the plan, such as the case of using in-house resources. In this case, it is possible to re-optimize the plan and produce revised crews

with new start and finish dates and oblige the existing crews to follow the new information. In the case of using subcontractors, also, it is possible to re-optimize less frequently, such as every month, and restrict corrective actions to the activities that did not start yet with enough time to inform the subcontractors of any revised plans and if necessary, renegotiate with them. It is also possible to use the optimization to introduce owner requested acceleration plans with the cost of changes paid by the owner.

## **5.5 Discussion and Summary**

This chapter introduced a computer prototype that is developed to automate the formulations of the scheduling and control framework for scattered repetitive projects. The prototype was developed using the VBA language of Microsoft Excel software and VB language and includes GA optimization routine. To demonstrate the usefulness of the prototype and its features, a real-life case study for a project that is commonly delivered at school boards was used. The prototype is capable of producing a near optimum baseline schedule using combination of construction methods, number of crews and activity specific site execution orders to meet the project deadline while minimizing the total project cost. During construction, the model records and incorporates the daily work progress into the schedule and produces corrective actions should the project deviates from the original plan to bring the project back on track with minimum additional cost.

## **Chapter 6**

### **Project Delivery Method (PDM) for Scattered Repetitive Projects**

#### **6.1 Introduction**

In previous chapter, a computer prototype to automate the proposed scheduling and control framework for scattered projects has been developed. To enable the project team to realize its potential benefits, it is essential to determine the most suitable project delivery method that suits scattered repetitive projects and allows for the use of the prototype's optimization features. This chapter, therefore, discusses the pros and cons of common project delivery methods used in typical scattered projects, and the factors that dictate the selection of the proper project delivery method. Afterwards, a modified project delivery method that takes into consideration the unique characteristics and challenges of scattered projects is introduced and its potential benefits confirmed with experts on facility rehabilitation programs.

#### **6.2 Typical DBB and CMR Project Delivery Methods**

Historically, the Design-Bid-Build (DBB) is the “standard” project delivery method for most public-sector organizations that are obliged to comply with local, provincial or federal procurement regulations. DBB competitive tendering process allows contractors to compete for projects, and owners to obtain the most competitive prices to reduce the tax-payers' expenses. Most of elementary and secondary schools, post-secondary education facilities, bridges, highways, hospitals, military bases, power plants, etc. were built using DBB. Generations of public-sector administrators have used the DBB, with consultants, and contractors are familiar with their roles and responsibilities under this delivery method. Standard contracts have been developed by most owner organizations to further simplify projects delivered using the DBB. Despite such long history and extensive implementation, the

drawbacks of this delivery method are widely recognized in the literature and in the industry (Hegazy 2002; Alkhalil 2002; Mahdi and Alreshaid 2005; Becker and Murphy, 2008; Rajos and Kell 2008; Ghavamifar, 2009; Rosner et al., 2009; Culp, 2011; CMAA, 2012; Shrestha et al. 2012; Carpenter and Bausman, 2016). To clearly illustrate the major disadvantages of DBB, a real-world case study to deliver a large non-repetitive building project for large public-organization, with a budget of about \$70M, is discussed.

**Selection of the Architect:** The Owner posted a Request For Proposal (RFP) on the online MERX site to attract interested qualified architectural firms. The proposals were evaluated by the owner and interviews were conducted with top candidates, and the successful proponent was awarded the contract. The architect subcontracted portions of its scope of work to specialized consulting engineers, including structural, mechanical, electrical, and specialized architects such as landscaping architect, who worked collaboratively to complete the design. In addition, the architect also provided environmental, permitting, and hearings for public approval services. The architect's contract was a fixed price contract and was based on Ontario Association of Architects (OAA) contract, Document 600 for 2008.

**Selection of the Contractor:** Once the design was completed, the bid package was presented to several previously short-listed contractors, who submitted lump sum prices for the work. The bidding period was approximately four weeks. The owner and the A/E team reviewed the received bids, then awarded the contract to the general contractor (GC) who was the lowest compliant bidder, and the contract followed the Canadian Construction Document Committee (CCDC2)-Stipulated Lump-Sum Price.

**Major Challenges with DBB:** Despite all the due diligence done by the owner to ensure successful project delivery, the project suffered significant delays that caused adversarial relationships between the owner, consultants, the GC, and the sub-contractors. This resulted in a series of delay claims, disputes, and litigations among all parties. These problems can be attributed mainly to the nature of the DBB method and could have been avoided if another collaborative delivery approach had been utilized. The encountered problems were as follows:

**Inability to Fast Track:** Due to the separation between the design and construction, fast tracking construction couldn't be done since the whole design and bidding stages had to be fully complete before the start of construction, as DBB dictates, and this took a long time. Early during construction, the shoring and excavation took much longer than anticipated, which caused significant project delays. This was partially because shoring was scheduled in Winter and was caught in a very tough weather. If the project was fast-tracked, the shoring and excavation could have started earlier while the A/E team was working on completing the design. This could have saved the project several months of delay.

**Lack of Constructability Feedback during Design:** The A/E team produced a design that perfectly met the aspirations and needs of the users, however, the absence of constructability input into the design (due to the separation between design and construction) caused major constructability issues. Alternate structural systems for example, could have been utilized to simplify the construction process and save the project significant amount of time. The architect had specified curtain wall system that is fabricated in California. The shop drawings approval process, the transportation, customs clearing, and the fluctuation in currency exchange rate caused significant delays to the project. Alternative local materials and systems could have saved the project several weeks. These constructability issues could have been avoided if the constructor has participated and provided feedback during the design process.

**High Potential for Disputes:** In this project, there were several scope disputes between the GC and the sub-contractors which caused significant delay to the project. Often, sub-contractors claimed that certain portions of the work were not included in their scope and they are entitled for extra compensations to complete this work. These disputes have occurred because the GC usually receives the bids from the sub-contractors few hours, sometimes few minutes, before the tender closing and the GC does not have enough time to analyze these bids and review what the sub-contractors included and excluded from their scope. This led to disputes and claims during construction. This lack of transparency in DBB delivery method was a major obstacle for the owner to resolve and move the project forward.



**Large Number of Change Orders:** Similar to most projects delivered using DBB delivery method, this project was exposed to a large number of change orders and claims by the GC and the sub-contractors over design coordination and constructability issues since the owner in DBB contracts holds liability for all the design details. As such, the number and cost of change orders could have been less if other collaborative forms of delivery method were used.

**Lack of Control over Sub-Contractor Selection:** Some sub-contractors who were recruited by the GC did not perform as expected. For example, the shoring, roofing, cladding, and sprinklers sub-contractors performed poorly. The shoring equipment were outdated, and not enough resources were used to timely complete the shoring. The sprinkler sub-contractor went bankruptcy and replacing them took several weeks. The delay of roofing and cladding also caused delays in the interior finishes such as dry wall, flooring, and painting. This poor selection of sub-contractors was due to the GC focus on lowest price and ignoring other sub-contractor reliability and quality factors. The owner had limited input to the retention of the sub-contractors as they were selected by the GC during the tender phase. Had these sub-contractors pre-qualified, most of these delays could have been avoided.

In recognition of the above disadvantages of DBB, several project delivery methods were implemented since the 1980s. Among these, the Construction Manager-at Risk (CMR) has gained wide use. The roles and responsibilities of all the project parties under typical CMR arrangement are illustrated in Figure 6.1. and a comparison between the CMR and the DBB is summarized in Table 6.1.

**Table 6-1: Comparison between DBB and CMR**

	<b>DBB</b>	<b>CMR</b>
<b>Pricing</b>	Competitively priced	Partially competitively priced
<b>Construction Feedback</b>	No constructability feedback during design	Allow constructability feedback during design
<b>Procurement Approach</b>	Lowest bid	Best Value
<b>Budget Certainty</b>	Provide budget certainty at early stage.	Budget is determined at late stage
<b>Fast Tracking</b>	Doesn't facilitate fast-tracking	Facilitate fast-tracking
<b>Change Orders</b>	Excessive number of change orders	Less excessive number of change orders
<b>Transparency</b>	Lack of Transparency	Better Transparency
<b>Relationships</b>	Adversarial relationships among parties	Collaborative and productive atmosphere

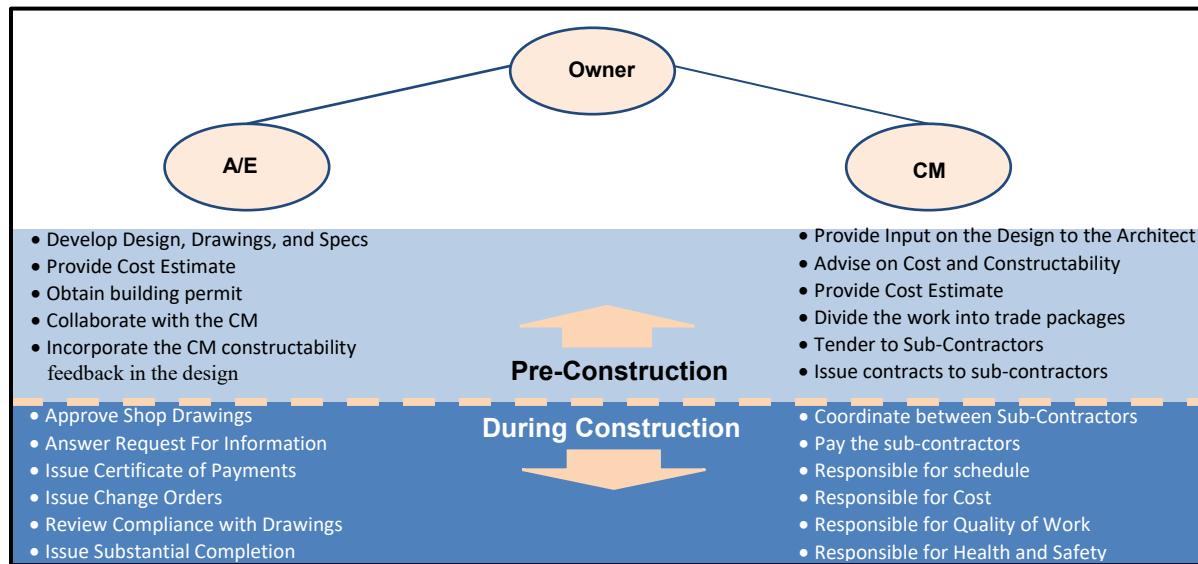

**Figure 6.1: Roles and Responsibilities for Project Parties under CMR Structure**

The CMR addresses many of the DBB drawbacks and provides more flexible and collaborative environment to deliver construction projects. Its main advantages are as follows (Alberta Infrastructure, 2001; Williams, 2003; Mahdi and Alreshaid, 2005; Becker and Murphy, 2008; Minchin, 2009; CMAA, 2012; Carpenter and Bausman 2016; Farnsworth et al., 2016):

**Best Value Approach to Construction Manager (CM) Selection:** The CMR selection process is based on the best value as opposed to the low bid in traditional DBB. The CM is selected for its experience with similar projects in size and complexity, qualification of the proposed team, technical and financial capacity, litigation history, health and safety records, references and fee. This approach improves the quality of the selection process, eliminates poor performers, and allows the owner to hire the best-qualified CM to deliver the project.

**Constructability Feedback during Design:** The CM is usually engaged early in the design phase and work collaboratively with the owner and the consultant to develop a greater understanding of the project schedule and budgetary goals. This collaborative approach produces an enhanced design because the CM assists the A/E team to identify potential constructability issues and resolve them during the design phase. The CM suggests more feasible materials and equipment, more constructible building systems, provides real-world

data for the project costing, and performs accurate constructability reviews. The CM often conducts value engineering when necessary to ensure the design is developed within the owner's budget. As a result, the number and the value of change orders during construction should be reduced when CMR is utilized.

**Ability to Fast-Track:** CMR facilitates fast-tracking construction for projects with challenging deadlines. Because of the CM early involvement in the project, the CM divides the project into work packages for each trade. Initial tasks such as shoring, excavation, and foundation work, can be tendered and the construction starts while the A/E team is developing the remaining of the design. This overlapping of the design and construction activities provides the project team with significant schedule advantage to complete construction projects on time.

**Collaborative Atmosphere:** The CMR arrangement fosters the culture of collaboration among the project parties rather than common adversarial environment usually dominates the DBB environment. This collaborative process leads to early problem solving and reduces disputes and claims, through the development of trust and focusing on common goals. This collaborative atmosphere enables the project team to make informed design and procurement decisions to enhance the quality of the facility and allows a smoother transition between design and construction.

Despite the advantages of the current CMR delivery method, it has several shortcomings that are recognized in the literature and expressed by the industry experts, particularly the administrators of public-sector organizations. While most of them agree that CMR provides a significant schedule advantage, they pointed out that projects delivered using CMR tend to cost more than projects delivered using the traditional DBB. This serious disadvantage could be attributed to the following (Konchar and Sanvido 1998; Alberta Infrastructure, 2001; Williams 2003; Rajos and Kell 2008; CMAA, 2012; Farnsworth et al. 2016):

**Work Is Not Competitively Priced:** One of the typical CMR most noticeable disadvantages is the lack of consistent and comprehensive competitive bidding procedures. As such, the owners are not guaranteed to obtain the most competitive prices and utilizing CMR would likely cost more than the traditional DBB. Architects and public-sector administrators have expressed their desire to enhance CMR procurement arrangements to ensure competitive market bidding procedures. The current procurement practices are not comprehensive enough to ensure the owners obtain the best value. Typical CMR practices do not provide specific instructions to limit the work performed by the CM own-forces. As such, the CM can perform portions of the work without being subject to proper competitive bidding. In several projects, the CM convinced the owner to use own-forces to perform tasks such as forming, concrete, and rough carpentry. Thus, a significant portion of the work was awarded to the CM without real competitive bidding, and accordingly, these services are likely to cost the owner more than the competitive market price.

Furthermore, the current practices allow a large portion of the CM services to be included in the “General Conditions”, without being competitively priced. The General Conditions include all fixed and variable indirect costs such as CM staff salaries, bonding and insurance, temporary site facilities, security, power consumption, hoisting, traffic control, temporary roads, small equipment, cleaning, general labor, etc. These costs represent a significant percentage of the project cost and could account for approximately 8-10% of the total construction cost. Owners under typical CMR have little means to ensure they are charged the most competitive market value for these services.

**Contract Forms:** Several contract forms between owners and constructors are used to facilitate CMR projects. The most commonly used contract forms in Canada are developed by Canadian Construction Document Committee (CCDC)-Construction Management for Services and Construction and is usually referred to as CCDC-5B. The contract forms include terms and conditions that determine the roles and responsibilities of all project parties. Some of these contract forms expose the owner to additional expenses that increase the project cost. The CM is not encouraged to minimize the project costs or complete projects on time because

the CM is compensated for change orders and additional time spent on the project. Some owners mitigate these risks by establishing Guaranteed Maximum Price (GMP) at a certain point (usually toward the end of the design phase) to provide certainty to the project budget. However, this certainty comes at a significant cost to the owner because the CM usually includes contingencies to account for risks that may not occur. These contingencies are premium costs to the owner and increase the total project cost.

**Inefficient Sub-Contractors Selection Process:** Typical CMR does not have consistent and comprehensive procedures to procure sub-contractors in a transparent and real competitive fashion to ensure the owner obtains the most competitive market prices. Typical CMR practices request the CM to present a minimum of three prices to the owner for each package. However, it does not provide consistent and specific instructions to the CM on how to develop the list of bidders to open the bidding process to a wide pool of qualified sub-contractors. Furthermore, the tendering process is usually managed entirely by the CM without sufficient involvement from the owner and the consultant to ensure transparency and competitiveness. This process has been criticized by architects and owner organizations because of its lack of real competitive bidding and therefore the loss of potential cost savings.

### **6.3 Challenges with Delivering Scattered Repetitive Projects**

The pros and cons discussed above for DBB and CMR are general to any project. Since scattered projects are delivered mainly based on a version of DBB, the disadvantages become more apparent. Although CMR can alleviate some of the drawbacks, the nature of scattered projects requires modifications to CMR to avoid the drawbacks. Before proposing improvements to the delivery methods for scattered projects, the typical DBB implementation is first discussed below and the nature of scattered projects are highlighted in order to provide practical improvements to CMR delivery method. The utilized project delivery method, and the owner management team members' titles and roles may vary slightly from one organization to another.

The typical DBB implementation for infrastructure scattered repetitive projects at many of school boards and universities can be summarized as follows:

- The owner assigns each individual project at any specific site to one of the in-house Design Project Manager (DPMs). This means that in a boiler replacement program for 20 schools, and with two DPMs assigned to boiler work, each DPM is in charge of 10 separate boiler projects, which is a large administrative work to manage at the same time;
- The DPM develops the scope and preliminary budget for each project at each site;
- The DPM retains a consultant (10 for the assigned 10 boiler projects) to develop the design, drawings, and specifications for each project at each site. Once the design is complete, the DPM turns over the 10 projects to an in-house Construction Project Manager (CPM) to manage the delivery phase;
- The CPM tenders each of the 10 projects individually to contractors, which is also a large administrative work. The CPM receives, reviews, analyzes all the individual bids, and then awards each contract to the lowest compliant bidder (10 contracts);
- The CPM coordinates the construction activities with each consultant and contractor teams for each project at each site. The CPM monitors project progress, ensure RFI are answered and shop drawings are approved in a timely fashion, reviews and negotiates change orders, process progress draws, resolves disputes, and coordinates with the operation staff of each facility to minimize the interruption to the facility operation, which is significant administrative efforts to manage at the same time; and
- Once the work on site is complete and the consultant issues the Certificate of Substantial Completion, the CPM processes the final payments, collects the closeout documents (i.e., as-built drawings, manuals, and warranties) and transfers the facility to the operation team.

The above DBB approach imposes several challenges that could lead to project delays and cost overruns, as shown in Figure 6.2, including the overload on the in-house project management team (DPMs and CPMs) to handle the projects individually. In addition, it deprives public-sector organizations from potential benefits and efficiencies that could be realized to help the cash-limited public-sector organizations to renew and maintain their aging infrastructure. A discussion of these drawbacks is as follows:

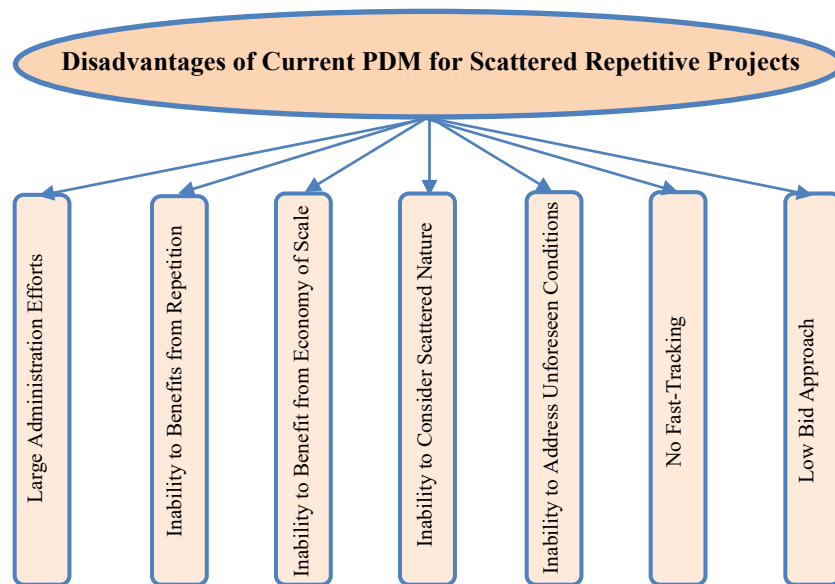

**Figure 6.2: Disadvantages of Current PDM for Infrastructure Scattered Repetitive Projects**

**Large Administrative Efforts:** Infrastructure scattered repetitive projects require substantial administrative efforts with regards to scope development, design, tendering, supervision, change orders management, dispute resolution, and cash flow management. Typical DBB requires significant coordination efforts to implement the annual programs since every project at each site has a separate team, i.e., the owner team (DPM and CPM), the constructor team (project manager, site superintendent, project coordinator etc.), and the consultant team (architects, engineers, site supervision etc.). This requires considerable administrative efforts and exerts significant pressure on the owner project management team to ensure the annual infrastructure renewal program is properly implemented.

**Inability to Benefit from Repetition:** One of the major advantages of repetitive projects is the ability to move crews between units (sites in case of scattered projects) in a synchronized fashion and benefit from the learning curve the trades develop. Such utilization significantly improves the working crew’s productivity and reduces utilization costs. The more times an activity is performed, the shorter the time it takes the working crew to complete, which is known as the learning curve effect. When a crew completes work at one site and moves to the next, they benefit from what they learned at the previous site and the task at the following site will be done more efficiently (Arditi et al., 2001; Jarkas, 2016; Malyusz, 2016; Srouf and Kiomjian, 2016).

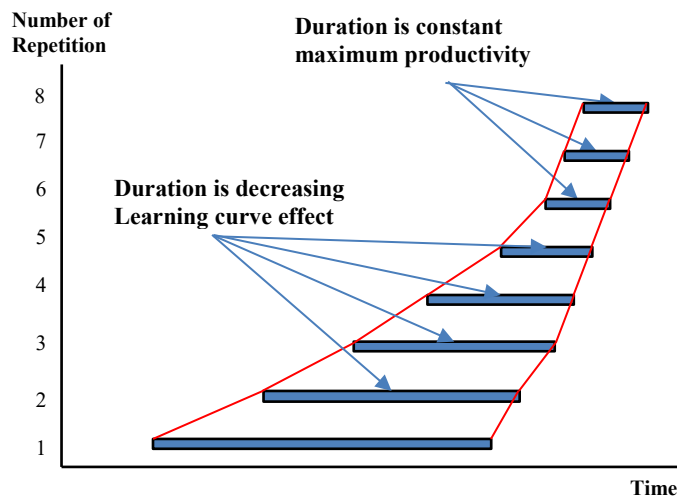

**Figure 6.3: Learning Curve Effect**

In current practices, the sub-contractors complete their task and leave without using the knowledge they acquired from completing the work at one site in another site. This lack of continuity deprives infrastructure renewal programs significant efficiencies. The proper project delivery method should enable the project team to maximize the benefits of the learning curve effect, eliminate unplanned work interruption and facilitate work continuity along the scattered sites in a synchronized manner. Accordingly, projects at multiple sites should be under the command of one management entity as opposed to a separate contractor for each project at each site.



**Inability to Benefit from Economy of Scale:** Infrastructure renewal projects are usually large projects and involve rehabilitation of multiple facilities. For example, the School Board invested more than \$92M in 2015/2016 on projects to improve the condition of its facilities. These large size investments create opportunities to benefit from the economy of scale. The current project delivery method at many public organizations divides the entire infrastructure rehabilitation program into small projects. Each project is procured separately, which denies public-sector organizations from realizing the benefits of the economy of scale in procuring the materials, equipment, and services necessary to complete these projects. The ideal project delivery method should enable owner-organizations to capitalize on this characteristic and maximize the benefits of such large investments to realize maximum possible efficiency. Thus, re-invest the realized savings in further improving the condition of their infrastructure.

**Inability to consider the Scattered Nature:** Infrastructure renewal projects are scattered across large geographical areas at multiple sites (buildings, highway sections, bridges, buildings, etc.). Local conditions, such as intensity of use, union jurisdictions, unforeseen conditions, and municipalities by-laws may vary from one site to another. The current delivery method doesn't recognize this unique challenge and limits the project team ability to mitigate its impact, and to schedule the work at each site when it has the highest possible productivity. Accordingly, an effective project delivery method should place infrastructure renewal projects at multiple sites under the control of one constructor to properly plan and lead this dynamic process to realize the potential benefits of the proposed framework.

**Inability to address Unforeseen Condition:** Most of the infrastructure scattered renewal projects take place at old facilities with inaccurate as-built drawings that do not show the actual condition of the structural, mechanical, electrical, and building envelop systems. Furthermore, the project teams are unable to conduct a thorough pre-construction field investigation to determine the actual facility condition to avoid interrupting the facility operation. Coupled with the lack of constructability feedback during the design phase, this often results in inaccurate design drawings which lead to a large number of change orders as shown in Figure 6.4.

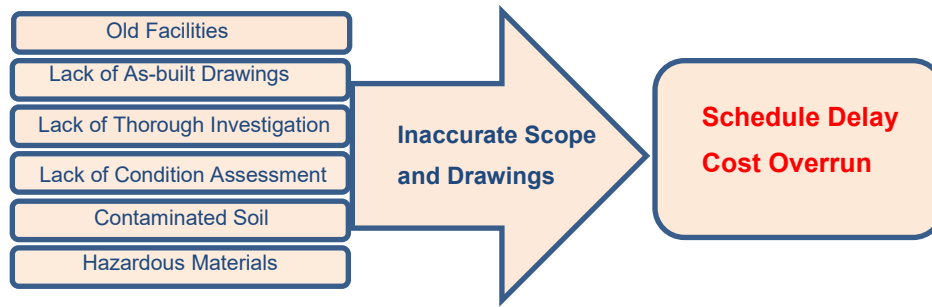

**Figure 6.4: Causes of Unforeseen Conditions**

The process of initiating, pricing, reviewing, negotiating, and approving change orders is lengthy, disruptive and promotes adversarial relationships rather than cooperation among the project parties. The ideal project delivery method should provide the project team with tools to minimize the number of change orders, the transparency to effectively negotiate when they occur and to reduce their impact on the project cost and schedule.

**Inability to Fast-Track Projects with Tight Deadlines:** Most of infrastructure renewal projects at universities and school boards are executed during the summer where classes are not in session to minimize interruption. This imposes challenging deadlines that require fast tracking and overlapping between different phases of the project. Typical DBB doesn't allow fast-tracking approach which cause delays to numerous infrastructure renewal projects. An effective project delivery method should enable fast-tracking construction for projects with a challenging deadline in a cost-efficient manner.

**Lowest Bid Approach:** Public-sector organizations adhere to strict procurement regulations to ensure fairness, openness, consistency, and transparency in procuring goods and services. In Ontario, for example, all publicly funded organizations must follow the Broader Public Sector Procurement Directive (BPSPD). The BPSPD establishes the rules that public-sector organizations must follow with respect to the required number of quotes, the process to obtain those quotes, the analysis and evaluation, and the award of contracts. To ensure full compliance with the BPSPD, most of the public-sector organizations prefer to use DBB which dictates the

use of lump-sum prices and award the contract to the lowest compliant bidder. This procurement approach exposes owner organizations to the risk of receiving lower quality products and services as contractors might try to lower their cost. In addition, projects delivered using DBB are likely to have a large number of change orders, disputes, and claims which lead to schedule delays, cost overruns, and adversarial relationships between the project parties. Project management teams usually allow for up to 15% contingency to account for potential change orders cost for infrastructure renewal projects.

#### **6.4 Modified Construction Manager at Risk (MCMR)**

In recognition of the previously discussed DBB drawbacks when applied to the scattered repetitive projects, and the disadvantages of typical CMR that are expressed by architects and public-sector administrators, a Modified Construction Manager at Risk (MCMR) delivery method is introduced. The MCMR takes into consideration many advantages that CMR arrangement provides, addresses all the concerns that were expressed by the industry experts, particularly representatives of the public-sector, and considers all the lessons learned from previous CMR projects. The seven-step procedures of the proposed Modified Construction Manager at Risk (MCMR) are shown in Figure 6.5.

**Step 1-Planning and Resource Allocation:** The owner Asset Management team determines the infrastructure renewal projects for the coming year. The owner assigns to each DPM and CPM their share of these projects. Afterward, the DPM and CPM, instead of dealing with these projects individually, they bundle them into groups of scattered repetitive projects. The DPM develops scope of work and preliminary budget based on the previous years' experience for each combined project.

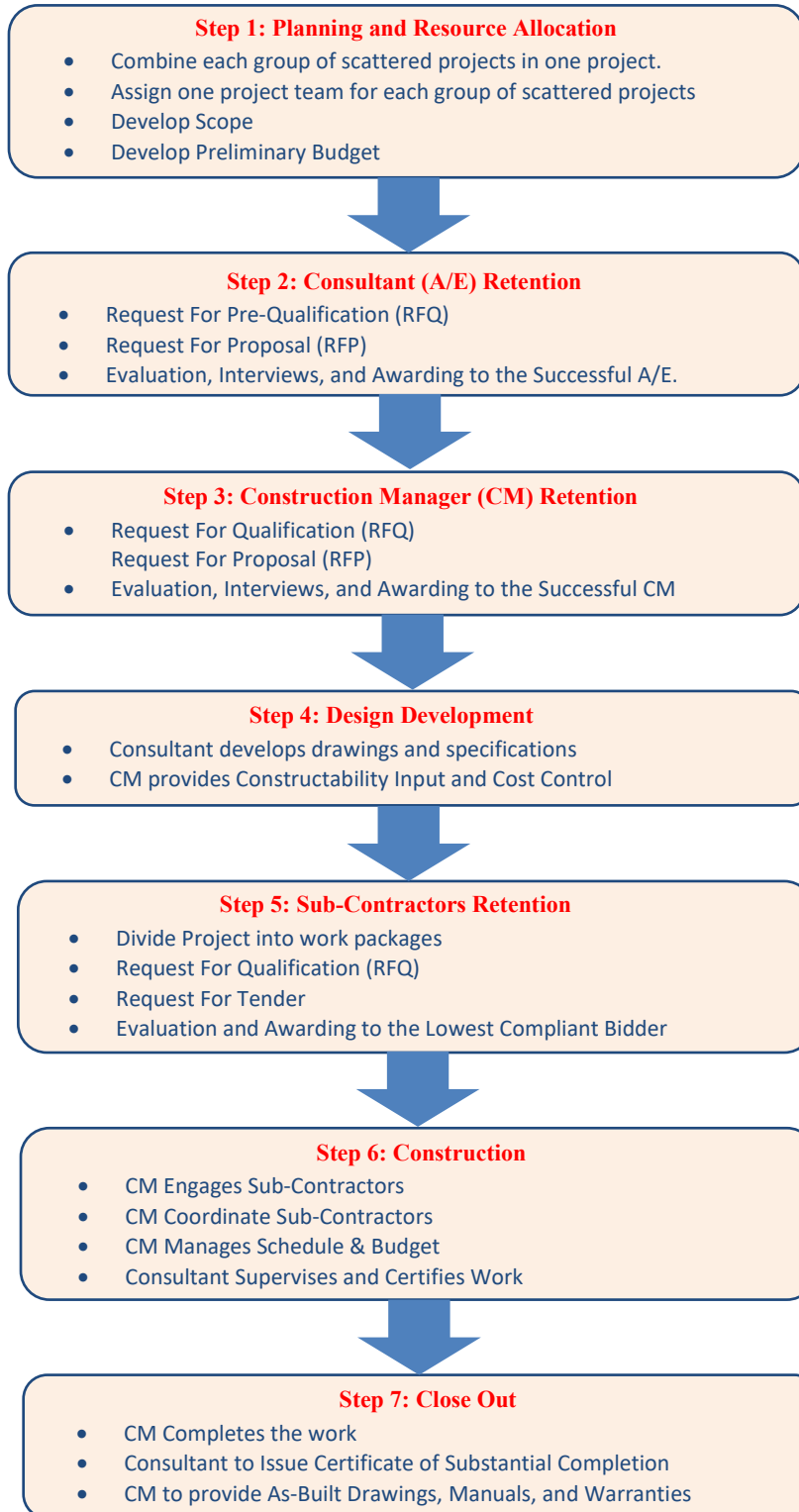

**Figure 6.5: Modified Construction Manager at Risk (MCMR) Structure**

**Step 2-Architect/Engineer (A/E) Selection:** The owner team posts a Request For Qualification (RFQ) on MERX to attract qualified architectural/engineering (A/E) firms to submit their qualifications (i.e., company profile, previous experience, quality of the project team, references etc.). Then the owner issues a Request For Proposal (RFP) to a shortlisted firms that thoroughly describes the expectations from the A/E at every stage of the project. The A/E firms submit their final proposal that includes their design vision to meet the owner specified needs, experience with similar projects in size and complexity, sub-consultants experience, plans to meet the project time and budget, the quality of the project team, and their fees. The received proposals are then evaluated, and the contract is awarded to the successful proponent. The contract forms commonly used in Ontario are developed by the Ontario Association of Architects (OAA). The contract includes general terms and conditions that determine the roles and responsibilities of the owners and architects. MCMR includes “Supplementary Conditions” to the OAA contract general conditions to ensure owners’ interests are protected and will not be exposed to unexpected additional charges.

**Step 3-Construction Manager (CM) Selection:** Hiring a capable CM and having proper contractual arrangements that clearly determine the roles, responsibilities, and expectations from the CM is a significant success factor for the modified delivery method. The CM should be engaged early in the project and by the time the consultant team completes the schematic design and develops a proper budget (Class C estimate), the CM should be retained.

The owner posts Request For Pre-Qualification (RFQ) on MERX, to attract qualified constructors to submit their qualifications (i.e., experience with similar projects, knowledge, and experience with the CMR delivery method, quality of the project team, health and safety record, litigation history, bonding capacity, references etc.). Then the owner issues a Request For Proposal (RFP) that describes the expectations from the CM at every stage of the project to a shortlisted firms. The bidders submit their final proposal that includes a description of their experience, plans to complete each stage of the project (i.e., design, procurement, construction, and post-construction), the quality of the project team, and their fees. The owner team then evaluates the proposals, and the contract is awarded to the successful bidder.

Unlike the typical CMR, the MCMR includes the following General Conditions' items in the CM proposed fees at the time of tender to obtain the most competitive market value for these services through competitive bidding process:

- a) Staffing costs such as salaries of the CM team for principals, administrative staff, project manager, project coordinator, site superintendent, assistant site superintendent, supervisors, health and safety coordinator etc.;
- b) Bonding and Insurance cost;
- c) The cost of temporary site offices, furnishing, office supplies and maintenance; and
- d) Transportation and accommodation for site personnel, parking, telecommunications, internet, and printing.

For the remaining of the General Conditions items, the MCMR stipulates that the CM obtains competitive prices for temporary rented equipment, purchased materials, hoisting, fencing, traffic control, and security. MCMR limits the size of the work performed by the CM own-forces to a small number like \$10,000. The MCMR specifies that the CM fees is a fixed lump sum and does not allow CM markups on the change orders during the construction. This important condition encourages the CM to complete the project on time as there will be no additional financial compensation for extending the project duration. It incentivizes the CM to complete the project with the least possible number of change orders. The CM fee is fixed and not a percentage of the total construction cost and change orders will only cost the CM time and efforts without financial compensation.

**Step 4-Design Development:** The consultant and the CM work collaboratively to develop the project design, drawings, and specifications. The CM provides feedback during the design phase by suggesting more feasible materials and products, real-world data for the project costing, and accurate constructability reviews to enhance the design efficiency. This should eliminate constructability issues and produce well-coordinated drawings to minimize the number of change orders and interruptions during the construction. When necessary, the CM

conducts Value Engineering to ensure the project is designed to meet the pre-determined budget. The CM monitors the project budget by developing cost estimates at the end of each design stage (i.e. schematic design, design development, and contract document) to flag any budgetary issues. Early work packages such as demolition, shoring, excavation, and foundations are tendered, awarded, and completed while the A/E team is working on the remaining of the design. Furthermore, long lead items such as boilers, chillers, air handling units, fume hoods, and transformers are tendered earlier to guarantee timely delivery.

**Step 5: Procurement of Sub-Contractors:** This is the most important step and a major success factor for this modified delivery approach, as sub-contractors' tenders count for more than 80% of the construction cost. The MCMR enhanced procurement process for retaining the sub-contractors considers all the shortcomings associated with typical CMR and provides opportunities to obtain the most competitive market prices and realize maximum possible savings. The modified procurement process is conducted in two stages:

**First Stage:** The CM divides the scope of work into trade packages, such as Demolition, Excavation, Shoring, Forming, Mechanical, Electrical, Drywall, Flooring, etc. Then, a Request for Qualification (RFQ) is posted on MERX to attract qualified sub-contractors to submit their qualifications (i.e., the company profile, experience with similar projects in size and complexity, health and safety records, litigation history, and references). The owner, consultant, and the CM collectively short list qualified subcontractors that have the capacity, experience, and the qualified team to complete the work satisfactorily.

**Second Stage:** The CM and the owner invite the short-listed sub-contractors to submit bids. All the questions and requests from the bidders are answered by the project team through formal addenda to all bidders at the same time to ensure fairness. Tenders are delivered in sealed envelopes to the owner's office (or submitted electronically) and opened in the presence of the CM in a formal and recorded procedure. The project team reviews and analyzes the received bids and awards the contracts to the lowest compliant sub-contractors. This approach opens the bidding to a wide pool of qualified sub-contractors to compete different and obtain the most competitive market value.

**Step 6-Managing the Construction:** During construction, the CM's role becomes similar to the GC's role in traditional DBB projects. The CM supervises and coordinates the subcontractors' activities to complete the work in accordance with the contract documents. The CM acts on behalf of the owner in negotiating additional cost claims by sub-contractors and ensures the owner is fairly charged. The CM provides a regular schedule update, usually bi-weekly, to flag out any scheduling issues, and recommends measures to bring the project back on track in case of detected delays. The CM issues a monthly progress draw to the consultant and the owner for review and payment. The CM assumes the responsibility to execute the project within the specified deadline. The MCMR includes incentives clause in the contract to pay the CM additional specified amount of money per day in case of early completion. It also includes liquidated damages to deduct specified amount of money per day in case of schedule delay. In addition, the MCMR includes most of the general condition items in the CM fees at the time of tender. Accordingly, the CM is encouraged to complete the project on time and within budget to realize targeted profits, avoid financial losses, and reputational damages. The A/E team is responsible for the supervision, contract administration and certification of the performed work. The A/E team conducts periodical site reviews and inspections, approves shop drawings, answers RFIs, issues COs, and certifies progress draws.

**Step7: Project Close Out:** Once the CM completes the work, the A/E team (Structural, Mechanical, Electrical, and Architectural) conducts the final review and produces compliance letters to certify that the work was performed in general conformance with the project drawings and specifications. The prime consultant issues the Certificate of Substantial Completion to the CM who submits the closeout documents that includes the as-built drawings, maintenance manuals, and warranties.



## 6.5 MCMR Advantages and Evidence of Applicability

The proposed MCMR utilizes several measures to address the drawbacks of CMR (summarized in Table 6.2). For example, the MCMR includes the cost of major general conditions items in the CM fees at the tender stage and limits the work performed by the CM own-forces to obtain the most competitive market value. The MCMR comprehensive procurement method assures the project's services and products are procured in a real competitive fashion to realize maximum efficiency. Moreover, the owner's full involvement in the tendering process ensures transparency and effectiveness and guarantees the best market value. Furthermore, the MCMR removes the CM markup from change orders to encourage the CM to avoid change orders, whenever possible, to reduce the excessive number and value of change orders commonly encountered in traditional DBB.

**Table 6-2: Comparison between CMR and MCMR**

	<b>CMR</b>	<b>MCMR</b>
<b>CM Tender</b>	The CM Fee at the time of tender includes: <ul style="list-style-type: none"> <li>• Overhead &amp; Profit</li> <li>• Pre-construction services</li> </ul>	The CM Fee at the time of tender includes: <ul style="list-style-type: none"> <li>• Overhead &amp; Profit</li> <li>• Pre-construction services</li> <li>• Project team salaries</li> <li>• Bonding and Insurance</li> <li>• Temporary facilities</li> <li>• Accommodation and Transportation</li> </ul>
<b>Sub-Contractor Tender</b>	<ul style="list-style-type: none"> <li>• Public pre-qualification is not common.</li> <li>• Tender of each package</li> <li>• Award to lowest compliant bidder</li> <li>• Limited owner involvement</li> </ul>	<ul style="list-style-type: none"> <li>• Public pre-qualification of each trade to develop short list of qualified trades</li> <li>• Tender of each package to the short-listed sub-contractor</li> <li>• Award to lowest compliant bidder</li> <li>• Full owner involvement</li> </ul>
<b>CM Own-Forces</b>	Allowed	Not allowed
<b>GMP</b>	Commonly adopted	No GMP
<b>Markup on Change Orders</b>	Allowed	Not Allowed

Because a real application case study of a scattered repetitive project does not exist yet, the verification of advantages and proof of applicability of the MCMR delivery system were quantified as shown in Fig. 6.6. First, the MCMR was applied to a real case study of a non-

repetitive project, which helped to quantify the benefits of the method. Second, a hypothetical application to a real repetitive rehabilitation project was applied and the expected benefits, as opposed to the DBB process, were perceived and highlighted.

**Case Study 1:** The first real case of applying the MCMR was a large non-repetitive building project, with a budget of approximately \$85 M. The proposed MCMR delivery method was applied to this case study. The project achieved a great success as it was completed on time with substantial cost savings. The project was fast-tracked because it had a tight deadline. Several work packages were tendered, awarded, and the work started months before the design was complete. For example, the demolition of the old building was tendered and started almost immediately after the selection of the CM. This was followed by the shoring and excavation that started and completed before the design was complete. Similarly, the foundation and super-structure were tendered and started while the A/E team was working on the design of the interior finishes. Such flexibility and overlapping between design and construction were a major success factor that helped the project team to meet a very challenging and tight deadline.

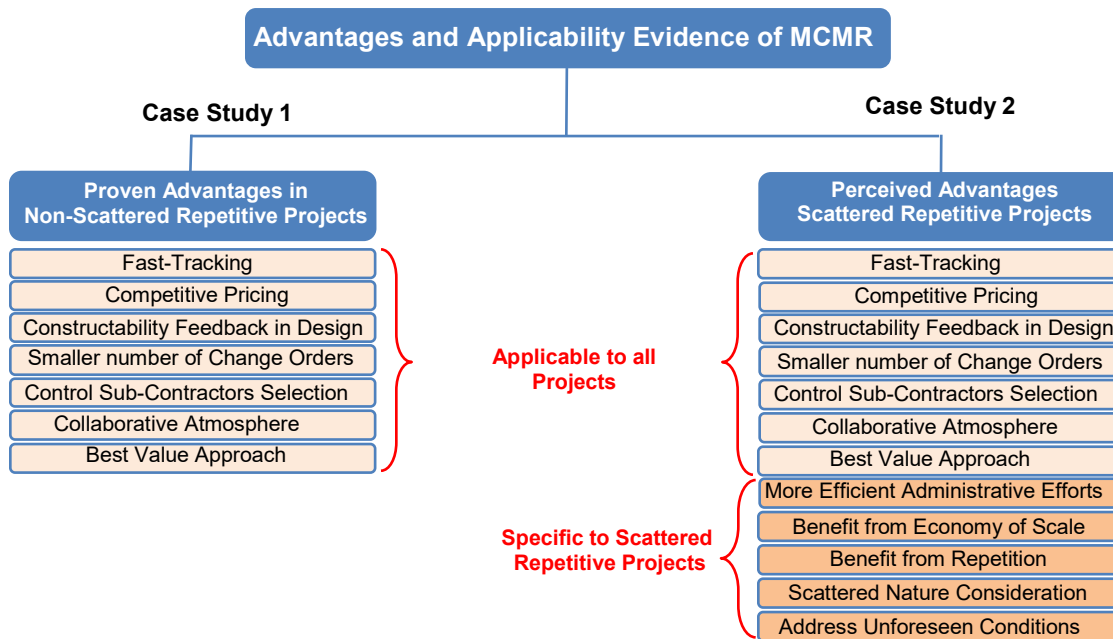

**Figure 6.6: Proved and Perceived Advantages of MCMR**

Following the MCMR procurement process resulted in substantial cost savings to the owner. The MCMR opens the bidding opportunities to a large number of qualified sub-contractors which creates opportunities for cost efficiencies. Developing a short list of capable sub-contractors based on their qualifications avoided the additional costs and delays that would have occurred by non-qualified sub-contractors lack of performance. Moreover, the owner's full involvement in the tendering process ensured transparency, and effectiveness and guaranteed the most competitive market value was attained. Furthermore, limiting the work performed by the CM own-forces, and including most of general conditions items in the CM fees at the tender stage ensured the whole project was subject to competitive bidding. This significant cost savings provided the project team with adequate flexibility to modify the design and include enhancement to the building as the tendering process advances.

The number and the value of change orders were significantly less than the number and value of change orders generated for other projects that used the traditional DBB. The cumulative value of the change orders (due to constructability and design omissions) was approximately 5% of the project cost as opposed to more than 10% of typical DBB projects. This was mainly attributed to the comprehensiveness of the MCMR procurement, early involvement of the CM and feedback into the design, and the removal of the CM markup on change orders. The latter encouraged the CM to avoid change orders, whenever possible, as they only cost the CM time and efforts without being compensated for these efforts.

**Case study 2:** The realized benefits of the MCMR delivery system are generic and could be applied to many types of projects particularly the infrastructure renewal scattered repetitive projects. Because a real application case study of a scattered repetitive project does not exist yet, a hypothetical implementation on a real scattered repetitive project is done to illustrate the applicability and perceived benefits of the MCMR to scattered repetitive projects. Therefore, the second case study is a hypothetical implementation of MCMR on the 2015 infrastructure renewal program at the School Board, which consists of approximately 340 small scattered projects, as outlined in Table 6.3.

**Table 6-3: Projects Completed at the School Board in 2015**

<b>Project Classification</b>	<b>Number of Projects</b>	<b>Contracts Value</b>
Roofing	104	\$20,825,066
Mechanical	56	\$13,595,822
Structural/Brick Work	23	\$21,577,976
Windows	9	\$3,084,100
Electrical	32	\$4,801,839
Barrier Free	7	\$1,141,312
Parking Lots	9	\$1,517,250
Field Restoration	23	\$9,866,543
Interior Components/Fascia/Painting	16	\$2,210,833
Other work	61	\$13,795,564
<b>Total</b>	<b>340</b>	<b>\$92,416,305</b>

The project management team consists of Construction Project Managers (CPM) and Design Project Managers (DPM) in addition to supporting staff (procurement, accounting, administrative, etc.). The size of the project management team may vary from one year to another to reflect the changing volume of work. Each DPM coordinates the scope, and the design for a large number of projects. Similarly, each CPM is responsible for managing the construction activities for a large number of projects and spends significant amount of time moving between sites to coordinate between project teams (i.e., consultant team and contractor team). Summary of perceived benefits and potential estimated cost savings of utilizing the MCMR as opposed to the traditional DBB is illustrated in Table 6.4. The following subsections discuss the perceived advantages of implementing the MCMR in delivering the case study infrastructure renewal program:

**More Efficient Administrative Efforts:** The total administrative cost is commonly estimated by facility management teams for small scattered repetitive projects to be approximately 6%-7% of the program cost (i.e., 7% of \$92.5M is about \$6.5m). The larger the size of the program, the smaller the percentage. By utilizing MCMR, the whole program of approximately 340 projects would be bundled in a manageable number of combined projects that is proportionate to the size of the project management team (for example, 10-20 projects).

Each combined project would have one consulting team, one contracting team, and one owner team. This structure significantly reduces the required coordination and the owner organization administrative efforts because most of the coordination would be done by the prime consultant and the construction manager. This efficient arrangement would enable the owner project management team to provide more supervision, monitoring, and project control, which would increase the efficiency by which infrastructure renewal projects are delivered. In addition, this arrangement would enable the owner project team to deliver the full annual renewal program, and expand their capacity to manage approximately 30% more projects, and as a result, would save the owner organization roughly \$2M.

**Table 6-4:MCMR Perceived Benefits over DBB: Case Study**

	<b>Current DBB</b>	<b>Proposed MCMR</b>	<b>Perceived Benefits</b>
Administrative Efforts	Large administrative Efforts	Less administrative Efforts	Reduced project cost
Economy of Scale	No benefit from economy of scale	Benefit from Economy of scale	Reduced project cost
Change Orders	Excessive number of change order	Smaller number of change orders	Reduced cost & duration
Fast-Tracking	Does not allow Fast-Tracking	Facilitate Fast-Tracking	Reduced project duration
Repetition (Cost of Labor)	No benefit from repetition	Benefit from repetition	Reduced cost & duration
Constructability Feedback	No Constructability Feedback	Constructability feedback	Less change orders.
Procurement Approach	Low bid approach	Best value approach	Promote quality and efficiency
Sub-Contractor Selection	No owner involvement	Full owner control	Qualified sub-contractors hired
Relationships	Adversarial relationships	Collaboration and trust	Less claims and disputes.
Unforeseen Conditions	Not properly addressed	Efficiently addressed	Reduced duration and cost
Scattered Nature	Not considered	Efficiently considered	Efficient resources utilization
Administrative Cost	\$6.5M	\$4.5M	\$2M
Economy of Scale-Design Fee	\$7.5M	\$6M	\$1.5M
Economy of Scale-Mat. & Eq.	\$38M	\$36.1 M	\$1.9M
Change Orders	\$11M	\$7.5M	\$3.5M
Repetition (Cost of Labor)	\$27M	\$25.6	\$1.4M
General Condition	\$9M	\$8.6M	\$0.4M
<b>Total Perceived Savings</b>			<b>\$10.7M</b>

**Economy of Scale:** One of the major advantages of the proposed MCMR is allowing owner organizations to benefit from the economy of scale. Combining multiple projects into one project would provide the project team with an effective tool to reduce the project cost. The majority of the contacted industry experts and related efforts in the literature agree that the discounted rates due to the bulk procuring of materials, equipment, and services would reduce the construction cost (Ariffine et al., 2016; Ramachandra et al., 2017). Furthermore, the economy of scale would significantly reduce the cost of design services. The fees charged by the A/E firms are usually a percentage of the construction cost. This percentage increases as the total construction value decrease. For example, a project of \$300,000 construction value could cost as high as 10% (or more) in design fee. A project of \$10,000,000 construction value, on the other hand, could cost as low as 6% in design fee (or less) (Carr and Beyor, 2005).

Utilizing the MCMR would combine the whole program in approximately 10-20 projects, each project with an approximate total cost of \$5-10M would enable the following economy of scale cost benefits:

1. The design fees for this size of projects would cost about 7% to 8% of the total construction cost or less as opposed to 10% or more in the current approach. This produces a significant 20% to 30% savings in the design cost (current estimate is approximately \$7.5M), which is approximately \$1.5 M to \$2.25M.
2. The efficient procurement of materials and equipment is estimated to result in approximately 5% to 10% savings of the total material and equipment cost (current estimate is approximately \$ 38M), which is about \$1.9M to \$3.8M.

Considering the conservative estimates, the benefits from the economy of scale in design fees and the purchasing of material and equipment is estimated to be approximately \$3.4M.

To a limited extent, Toronto District School Board has recently been implementing a simple and successful approach of bulk purchasing of roofing materials and installation work, which resulted in substantial reduction in the cost of roofing projects. This supports the suggestion that considering the economy of scale has a major advantage in cost savings, and that gradual implementation methods can target materials, equipment, and installation services.

**Repetition Advantages:** Utilizing MCMR would enable the project team to maximize the benefits from the repetitive nature of the scattered infrastructure projects, by placing projects at multiple sites under the command of one management team. The CM would be able to synchronize working crews among sites in an efficient manner to prevent idle times and realize the full benefit from the learning curve effect.

According to Jarkas (2016), Parker and Oglesby (1972) reported that the learning curve rate for the most construction activities is estimated between 70% and 90%. That means if an activity follows the 90% learning rate, and if it takes 100 labor-hours to build the first unit, it would take  $(90\% * 100)$  or 90 labor-hours to build the next two units. This productivity improvement continues until the productivity peaks and production rate stabilizes. Khanh and Kim (2014) investigated the effect of the learning curve on labor productivity of the three structure erection activities (i.e., formwork setting, rebar installation, and concrete casting) in high-rise building projects. Using the straight-line model, an approximate learning rate of 90% for each of the three trade-activities observed was determined.

For the case study at hand, using only 50% of the most conservative findings, which is 90% learning rate and for only one cycle (to allow for the scattered and non-typical nature of infrastructure renewal projects) would produce 5 % saving in time, and accordingly the cost of labor (current estimate is approximately \$ 27 M). This is significant \$1.4 M cost savings.

**Competitively Priced Services:** The proposed MCMR addresses an important disadvantage of typical CMR to owner organizations which is the additional costs they may incur due to the lack of comprehensive competitive bidding procedures. The proposed MCMR utilizes several measures to mitigate these risks as follows:

1. MCMR provides comprehensive procurement procedures to ensure services and products are procured in a real competitive fashion to realize maximum efficiency. Posting RFQ for sub-trades on a public website (MERX) opens the bidding opportunities to a large number of vendors which creates opportunities for efficiencies. Developing a short list of capable sub-contractors based on their qualifications eliminates poor performers and avoid additional costs that are caused by lack of performance of non-qualified sub-contractors. Moreover, the owner's full involvement in the tendering process provides transparency and effectiveness, and guarantees the best market value;
2. MCMR includes the cost of major general conditions items such as staff salaries, bonding, insurances, traveling, accommodation, and temporary site facilities in the CM fees at the tender stage. As such, all these services are competitively priced the most competitive market value is obtained; and
3. MCMR limits the work performed by the CM own-forces to a small number (about \$10,000) to ensure the entire project is priced competitively.

Estimated general condition is approximately 10 % of the construction cost. Utilizing MCMR would ensure the major items of the general conditions are competitively priced, and this would potentially reduce the cost of general conditions. Furthermore, the reduced number of projects would reduce the cost of the constructors' management teams (e.g. project manager, site superintendent, project coordinator, etc.) between 20% and 30% (current estimate is approximately \$2M), which is about \$400k to \$600k in cost reduction.



**Reduced Number of Change Orders:** Utilizing the MCMR in the scattered infrastructure renewal projects should result in reducing the number of change orders due to:

1. The early involvement and the participation of the CM in the design development, and the constructability feedback would improve the design drawings quality and result in lesser change orders;
2. Removing markup charges from change orders during the construction would strongly encourage the CM to avoid change orders, whenever possible, as they will only cost the CM time and efforts without financial compensation; and
3. The improved sub-contractor's selection process would eliminate poor performers and ensure only qualified sub-contractors are retained.

Utilizing MCMR would potentially reduce the value of change orders (from the currently estimated 15% to 10%) of the construction cost, which is a significant 33% reduction. This has potential cost savings of approximately \$3.5M.

**Effectively Address Unforeseen Condition:** The proposed MCMR would provide the project team with sufficient flexibility and transparency to address unforeseen conditions. For example, when unforeseen hazardous material is discovered, the transparency of the MCMR arrangement will allow the team to quickly determine the scope, negotiate a fair price, and complete the work. Furthermore, while the work is stopped at one site because of this unforeseen condition, the working crew could be re-assigned to another site until the issue is resolved. This flexibility would minimize the risk of project delays and cost overruns.

The other advantages such as collaborative approach, constructability feedback, and handling unforeseen conditions would contribute to reducing the number and value of change orders. Fast-tracking, crew synchronization, and schedule optimization among scattered sites would enhance the project team's ability to investigate various corrective action options and complete such large infrastructure renewal programs in a timely fashion.

The estimated potential total cost savings is approximately \$10M (about 10 % of the total program cost, including the administrative cost), which is a significant potential improvement over current project delivery methods for this type of projects. However, it is important to note that the estimated numbers including the cost breakdown (i.e., design cost, labor cost, material and equipment cost, general condition cost, etc.), and the possible cost savings and efficiencies are rough estimates and would vary from one project to another and from one organization to another.

## **6.6 Summary and Discussion**

Current DBB delivery method exhibits serious drawbacks when used to deliver repetitive and non-repetitive projects alike. The lack of constructability feedback to the design, the inability to fast-track projects with a tight deadline, the excessive number of change orders, and the adversarial relationship between parties usually associated with DBB are among those drawbacks. Most projects under this delivery method are experiencing delays, cost overruns, costly claims, and disputes. CMR was developed in the 1980s to alleviate some of the DBB shortcomings. CMR facilitates fast-tracking, allows constructability feedback, and promotes collaboration between parties. Projects delivered using CMR, however, experiences serious disadvantages. Most notably, the concern raised by the public-sector administrators that using CMR often results in additional costs as sizable portions of the project scope is not competitively priced and they may not be obtaining the most competitive market value for their projects.

In recognition of DBB drawbacks when applied to the scattered repetitive infrastructure renewal projects, and the major disadvantages of typical CMR, a Modified Construction Manager at Risk (MCMR) delivery method was introduced. The MCMR includes seven steps to deliver scattered repetitive projects from inception to completion. It takes into consideration the advantages that CMR arrangement provides; addresses many concerns that were expressed by the industry experts, particularly representatives of the Public Sector, and considers all the lessons learned from previous CMR projects.

The MCMR was used to deliver large non-scattered repetitive project and produced excellent results as the project was completed on time with significant cost savings. To demonstrate the perceived advantages of the MCMR when applied to scattered repetitive projects, a hypothetical implementation on real-life case study for 2015/2016 infrastructure renewal program at the School Board was used. The perceived benefits of MCMR to public-sector organizations are potential cost savings and improved chances to complete their infrastructure renewal programs in a timely manner.

## **Chapter 7**

### **Conclusion and Future Research**

#### **7.1 Introduction**

School boards, universities and other public organizations are faced with significant challenges to keep essential services and facilities operational due to lack of sufficient funding to renew the aging and deteriorating facilities. The infrastructure renewal bills for Ontario schools and universities are estimated to be as high as \$15-billion and 2.5-billion respectively. To bring these facilities to an acceptable and functional levels, Ontario government is funding hundreds of millions of dollars worth of infrastructure renewal projects every year. Significant efforts were dedicated to optimizing the allocation of the limited funding resources available for infrastructure renewal. Little efforts, however, addressed the implementation and the delivery phase of such costly and complicated projects.

The current practices in delivering infrastructure renewal programs at public-sector organizations were investigated and discussed. These projects are repetitive in nature and scattered across large geographical areas (schools, bridges, etc.). However, the current Design-Bid-Build project delivery methods consider every site separately, which deprive these organizations from benefiting from repetitiveness and its economy of scale to save cost and time. In addition, the current scheduling and control systems are not suitable to address the challenges of scattered repetitive projects.

Most of existing management systems at public-sector organizations do not provide in-house management teams with adequate decision support during the execution phase of their rehabilitation programs with regards to the execution planning and the project delivery methods. These methods exhibit serious drawbacks when applied to infrastructure renewal for

scattered repetitive projects. Most notably: the inability to consider the time and cost for the crews to move and mobilize equipment among sites; the complexity in optimizing the schedule; and the lack of visual representation that is easy to communicate among project parties. Moreover, the control aspect of existing systems is: unable to record daily site events made by the various parties; unable to visualize the evolution of progress events on the schedule; and unable to optimize corrective action plans. These drawbacks represent major challenges that lead to large cost overruns, schedule delays, and large accumulated backlog in implementation infrastructure renewal programs.

Having an effective scheduling and control system along with a suitable project delivery method would improve the chances of completing projects successfully and can potentially result in significant economic and social impacts through efficient utilization of the limited public funds and maximizing the benefits of the money spent.

## **7.2 Research Contribution**

The main objective of this study is to provide public-sector organizations (e.g., municipalities, school boards, and universities) with advanced decision support for optimized scheduling and project control that is tailored to the unique characteristics of infrastructure renewal projects. This is coupled with introducing a suitable project delivery method that has the required contractual landscape and flexibility to address the execution challenges.

To understand the unique challenges encountered by the construction team at public organizations to deliver their infrastructure renewal program, a comprehensive field study was conducted at one of Canada's major school boards and one of largest universities. Based on this study, the challenges that were set to be addressed in this research include: the scattered nature of infrastructure project; the need to synchronize multiple crews among multiple construction sites; need to account for the varying productivity factors at the different work sites; the variation of work quantities among the site; working at occupied facilities; and the need to enhance the current project delivery methods.

To address these challenges, an efficient scheduling and control framework was developed to provide sufficient decision support to address the nature of scattered repetitive projects. The framework combines the benefits of Line Of Balance (LOB) and the Critical Path Segments (CPS) techniques to provide a schedule optimization model that determines the best combination of construction methods, number of crews, and activity site orders that minimize the project total cost and meet deadline, while considering all the practical constraints identified in the investigation phase of this study.

The proposed framework also has powerful support for corrective action decisions during the construction phase. It allows timely recording of daily site progress events; interruptions (weather, resources issues, etc.); rework; acceleration, along with the parties responsible for these events. It then integrates these events on the repetitive schedule to update the project time and cost and facilitate corrective actions. This enables the project team to reactivate the optimization feature to bring the project back on track should it deviates from the original plan.

To demonstrate the usefulness of the model and illustrate its capabilities and features, a computer prototype system for scheduling, cost optimization, and control of scattered repetitive projects is introduced. To validate the effectiveness of the introduced model, a case study for a real-life project that commonly take place at school boards to renovate seven classrooms at seven different schools is presented. The results of the optimization experiments proved the suitability of the model to scattered repetitive projects.

To maximize potential benefits, the proposed framework attempts to address the current drawbacks of the DBB and CMR delivery methods when applied to scattered repetitive projects. This is done by introducing a modified Construction Management at Risk (MCMR) delivery method that allows public organizations to minimize administrative efforts and have better control over the delivery of scattered projects, taking advantage of the economy of scale.

At the detailed development level, the introduced schedule optimization framework along with the proposed MCMR delivery method have made a number of important contributions:

- **Better understanding of the challenges in scattered projects:** This research has provided in depth field study of the challenges encountered by public sector organizations in delivering their infrastructure renewal programs. It identified the need for better planning, scheduling, and control that takes into account the scattered and repetitive nature of these projects such as the synchronization of crews among sites with various work quantities and productivity factors, the moving time and cost between scattered sites, the impact of working in occupied facilities, and the inefficiency of current scheduling and tracking systems, in addition to the need for better contractual and project delivery practices to deliver these projects more efficiently.
- **New Schedule Representation for Scattered Projects:** This research introduces new LOB representations of the scattered repetitive projects considering the scattered nature of these projects and different site orders scenarios. It legibly separates the schedule of each crew according to its independent site order. This improves the ability of the project team to understand, interpret, analyze, and communicate the schedule information to all the parties.
- **Development of a Scheduling Model Suited for Scattered Repetitive Projects:** The study introduced a scheduling model for infrastructure renewal scattered repetitive projects. The model considers different construction methods, variation of work quantities among different sites, various crew assignments strategies, various productivity factors, activity-specific site order (rather than using one site order for all activities), and the time /cost of moving resources among sites. The immediate benefits of the latter two aspects have been demonstrated to greatly benefit the schedule.
- **Development of a High-Resolution Project Control Model for Scattered Repetitive Projects:** This research utilizes CPS methodology which was introduced for non-repetitive project to develop CPS-LOB control model for scattered repetitive projects. The enhanced CPS-LOB control mechanism is capable of capturing all mid-activity as-built events, and this provides high-resolution data for further delay analysis and

corrective action planning. Also, the accurate computation of remaining durations of activities leads to better assessment of the project deviations and, accordingly, allow the project management team to identify and implement more accurate corrective-action plans.

- **Development of a Genetic Algorithms (GA) Schedule Optimization Model:** This research uses evolutionary algorithms to determine an optimum baseline schedule during the planning phase and optimum corrective actions during construction considering various scheduling option as well as as-built information. The model enhances the project management team's ability to better control scattered repetitive construction projects through continuously identifying effective corrective actions that keep project cost and duration under control.
- **Development of a Computer Prototype for Practical Decision Support:** The study introduced a new computer prototype of the proposed model and experimented with real case studies of infrastructure renewal projects to automate the schedule updates and the identification of best corrective actions to bring projects back on track.
- **Enhanced Project Delivery Methods for Scattered Repetitive Projects:** This study thoroughly examined the current project delivery methods and identified their advantages and disadvantages when applied to infrastructure renewal scattered repetitive projects. Then an enhanced project delivery method, Modified Construction Manager at Risk (MCMR) is introduced to address existing drawbacks. The proposed MCMR provides public-sector organizations with necessary contractual tools that enables successful delivery of their infrastructure renewal program in a cost-efficient manner.

### 7.3 Future Research

- Enhance project tracking of complicated scattered repetitive projects by utilizing email-based system to collect daily site events. The use of such technology has great potential



to save time and efforts in collecting and recording project progress accurately and in timely fashion.

- Experiment other powerful optimization methods such as Constraints Programming (CP) to optimize the scheduling and cost optimization for large size and complicated infrastructure renewal scattered repetitive projects.
- Enhance the flexibility of the scheduling and the control model by allowing overlapping between activities at various sites. This has the potential to assist in improving resource utilization, reduce idle time, expedite more efficient corrective actions to recover project delays.
- While the developed scheduling and control framework chooses the proper construction method out of three available methods to minimize the total project cost and meet the deadline, the model applies the same construction method for all the task sites. This way doesn't allow the use of different construction methods at different sites, which can provide additional flexibility to the project. For example, a concreting task may use a concrete-by-pump method for 10 sites and prefab elements for another 10 sites.
- While the proposed model allows introducing designed work interruption, it does not account for the cost of such interruption in calculating the total construction cost. The cost of interruption could include the cost of crews staying idle on site, or the cost of demobilizing (moving off the site) and re-mobilizing (moving back to the site), whichever is less. It would be beneficial to include the cost of interruption to better reflect the actual total project cost.
- The developed scheduling and control framework assumes deterministic values for activities; cost, durations, number of crews and site execution orders. It is important however, to incorporate uncertainty and probabilistic approach in the development of the framework.
- The used case study for the scheduling model during the planning phase, was real life case study, however, the locations, events and scenarios used during the construction

phase to demonstrate the scheduling and control feature were hypothetical. It is important to experiment the control model with real life case study during the full length of construction.

- The perceived benefits of the modified project delivery method are calculated using empirical calculations based on the common practices. It would be useful to incorporate these benefits into the scheduling and the project control framework formulas to determine overall project duration and cost when the MCMR is used. In addition, an actual implementation of MCMR on an infrastructure renewal program for public sector organization would confirm its benefits and identify future refinement.
- While the GIS is used in this study to calculate the distances between sites to determine the moving time and cost, it would be beneficial to incorporate live GPS to update the local conditions such as traffic and weather momentarily. This would enable the model to calculate the moving time and cost in real time and better assess their impact on the overall project duration and costs.

## References

- Abdel-Monem, M., and Hegazy, T. (2013), "Enhancing construction as-built documentation using interactive voice response". *Journal of Construction Engineering and Management*, ASCE, 139(7), pp. 895-898.
- Abdel-Monem, M., Hegazy, T., and Saad, D. (2012), "Automated system for documenting the evolution of as-built details during construction". Transportation Research Board (TRB) 91<sup>st</sup> Annual Meeting, Washington, DC.
- Adeli, H. and Karim, A. (1997), "Scheduling/Cost Optimization and Neural Dynamics Model for Construction". *Journal of Construction Engineering and Management*, ASCE, 123(4), pp. 450-458.
- Ahlualia, S.S., (2008), "A Framework for Efficient Condition Assessment of the Building Infrastructure". Ph.D. dissertation, University of Waterloo., Waterloo, ON.
- Ahuja, H., Dozzi, S., Abourizk, S. (1994), (Project Management and Technologies in Planning and Controlling Construction Projects". John Wiley & Sons, Inc., NY, USA.
- Alberta Infrastructure, (2001), "An Owner's Guide to Using the 'Construction Management' Project Delivery System on Alberta Infrastructure Funded Building Projects".
- Al-Jibouri S. H., (2003), "Monitoring systems and their effectiveness for project cost control in construction". *International Journal of Project Management*, (21), pp. 145–154.
- Al-Sarraj, Z. (1990), "Formal Development of Line of Balance Technique". *Journal of Construction Engineering and Management*, ASCE, 116(4), pp. 689-704.
- Al Khalil, M., (2002), "Selecting the Appropriate Project Delivery Method using AHP". *International Journal of Project Management* (20) pp. 469-474.
- Alshaibani, A. (1999), "A computerized cost and schedule control system for construction projects". Master's Thesis, Department of Building, Civil and Environmental Engineering, Concordia University, Montreal, Canada.
- Ammar, M. (2013), "LOB and CPM Integrated Method for Scheduling Repetitive Projects". *Journal of Construction Engineering and Management*, ASCE, 139(1), pp. 44-50.

- Anastasopoulos, P.C., Labi, S., Bhargave, A., Mannering, F., L. (2012). “Empirical Assessment of the Likelihood and Duration of Highway Project Time Delays” *Journal of Construction Engineering and Management*, ASCE, 138(3), pp. 390-398.
- Ariffine, S., Sulaiman, S., Mohammad, H., Yaman, S., Yunus, R. (2016), “Factors Affecting Economies of Scale For Construction Contractors”. *International Congress on Technology, Engineering, and Science*.
- Arditi, D., Tokdemir, O., and Suh, K. (2002), “Challenges in Line-of-Balance Scheduling”. *Journal of Construction Engineering and Management*, ASCE, 128(6), pp. 545-556.
- Arditi, D., Sikangwan, P., and Tokdemir, O. (2002), “Scheduling System for High-Rise Building construction.” *Journal of Construction Management and Economics* (20), pp. 353-364.
- Arditi, D., Tokdemir, O., and Suh, K. (2001), “Effect of Learning on line of balance scheduling”. *International Journal of Project Management* (19), pp. 545-556.
- Assaf, S. and Al-Hejji, S. (2006). “Causes of delay in large construction projects”. *International Journal of Project Management*, 24 (4), pp. 349– 357
- Attalla, M., Hegazy, T., and Elbeltagy, E. (2004). “In-House Delivery of Multiple small Reconstruction Projects”. *Journal of Engineering in Management*, ASCE, 20(1), pp. 25-31.
- Attalla, M. and Kamarah, E. (2007), “Framework for Reducing Conflicts in Rehabilitation Projects” Proceedings of the 19<sup>th</sup> Conference on System Research, Informatics and Cybernetics, Baden, Germany.
- Bakry, I., Moselhi, O., and Zayed, T. (2014), “Optimized Acceleration of Repetitive Construction Projects”. *Journal of Automation in Construction*, ASCE, (39), pp. 145-151.
- Bansal, V.K., and Pal, M. (2009), “Construction schedule review in GIS with a navigable 3D animation of project activities”. *International Journal of Project Management* (27), pp. 532-542.

- Batselier, J., and Vanhoucke, M. (2015), “Empirical Evaluation of Earned Value Management Forecasting Accuracy for Time and Cost”. *Journal of Construction Engineering and Management*, ASCE, 141(11), pp. 1-13.
- Becker, J., and Murphy, T. (2008), “Alternative Construction Delivery Methods”. <https://mcmillan.ca/Files/AlternativeConstructionDeliveryMethods.pdf>
- Bolin, J., (2018), “Effective Change Order Management”. *Long International* ([www.long-int.com](http://www.long-int.com)).
- British Columbia Construction Association (BCCA), (2012). “Recommended Guidelines For the Selection of a Construction Project Delivery Method”.
- Carpenter, N., and Bausman, D. (2016), “Project Delivery Method Performance for Public Construction: Design-Bid-Build versus CM at Risk”. *Journal of Construction Engineering and Management*, ASCE, 142(10), pp. 1-10.
- Carr, P. and Beyor, P., (2005), “Design Fees, the State of the Profession, and a Time for Corrective Action”. *Journal of Construction Engineering and Management*, ASCE, 25(3), pp. 110-117.
- Chehayeb, N., and AbouRizk, S. (1998), “Simulation-Based Scheduling with Continuous Activity Relationships”. *Journal of Construction Engineering and Management*, ASCE, 124(2), pp. 107-115.
- Chen, Y., Q., Liu, J. Y., Li, B. G., and Lin, B. S. (2011), “Project delivery system selection of construction projects in China”. *Expert Systems with Applications*, 38(5), pp. 5456–5462.
- Cheng, M., and Ko, C. (2003), “Object Oriented Evolutionary Fuzzy Neural Inference System for Construction Management”. *Journal of Construction Engineering and Management*, ASCE, 129(4), pp. 461-469.
- Chin, S., Yoon, S., Kim, Y.S., Ryu, J., Choi, C., Cho, and C.Y. (2005), “Realtime 4D CAD + RFID Project Progress Management”. *Construction Research Congress, San Diego, USA.*, pp. 331-340.

- Chou, J.-S., Chen, H.-M., Hou, C.-C., and Lin, C.-W. (2010), "Visualized EVM system for assessing project performance". *Journal of Construction Automation in Construction*, 19(5), pp. 596-607.
- Chou, K., Hong, Y., and Hyun, C. (2010), "Integrated Schedule and Cost Model for Repetitive Construction Process". *Journal of Management in Engineering*, ASCE, 26(2), pp. 78-88.
- Chzanowski, E., and Johnston, D. (1986), "Application of Linear Scheduling". *Journal of Construction Engineering and Management*, ASCE, 112(4), pp. 476-491.
- Construction Management Association of America (CMAA), (2012), "An owner Guide to Project Delivery Method".
- Council of Ontario Universities (2014), "Ontario Universities' Facilities Conditions Assessment Program ".
- Clup, G. (2001). "Water and Wastewater Projects: Do They Save Time and Money". *Journal of Leadership and Management in Engineering*, 11(3), pp. 231-240.
- Damci, A., Aediti, D., and Polat, G. (2013), "Multi-resource Leveling in Line-of-Balance Scheduling". *Journal of Construction Engineering and Management*, ASCE, 139(9), pp. 1108-1116.
- Davidson, I. N., and Skibniewski, M. J. (1995), "Simulation of automated data collection in buildings". *Journal of Computing in Civil Engineering*, 9(1), pp. 9-20.
- Deferred Maintenance at Canadian Universities: An Update (2014). Canadian Association of Universities Business Officers (CAUBO).
- De la Garza, J. M., and Howitt, I. (1998), "Wireless communication and computing at the construction jobsite". *Journal of Automation in Construction*, 7(4), pp. 327-347.
- Dolabi, H., Abbas, A., and Abbasnia, R. (2014), "CPM/LOB Scheduling Method for Project Deadline Constraints Satisfaction". *Journal of Automation in Construction* (48), pp. 107-118.

- D'Onofrio, R., (2017), "CPM Scheduling: A 60-year History". *Journal of Construction Engineering and Management*, ASCE, 143(10), pp. 1-3.
- Duffy, G., Oberlander, G., and Jeong, D. (2011), "Linear Scheduling Model with Varying Production Rates". *Journal of Construction and Engineering Management*, ASCE, 137 (8), pp. 574-582.
- El-Asmar, M., Hanna, A., and Loh, W. (2012), "Quantifying Performance for Integrated Project Delivery System as Compared to Established Delivery Systems". *Journal of Construction and Engineering Management*, ASCE, 139(11), pp. 1-14.
- Elbehairy, H., Hegazy, T., and Soudki, K. (2009), "Integrated Multiple-Element Bridge Management System". *Journal of Bridge Engineering*, ASCE, 14(3), pp. 179-187.
- Elbeltagi, e. and Dawood, M. (2011), "Integrated visualized time control system for repetitive construction projects". *Automation in Construction* (20), pp. 940–953
- Elbeltagi,E., Hegazy, T., and Grierson, D. (2005), "Comparison among five evolutionary-based optimization algorithms" *Advanced Engineering Informatics* (19), pp. 43–53
- Eldin, N., and Senouci, A., (1994), "Scheduling and Control of Linear Projects" *Canadian Journal of Civil Engineering* (21), pp. 219-230.
- Elshaer, R., (2013), "Impact of sensitivity information on the prediction of project's duration using earned schedule method". *International Journal of Project Management* (31), pp. 579–588.
- El-Rayes K., and Moselhi, O. (1998), "Resource-Driven Scheduling of Repetitive Projects". *Journal of Construction Management and Economics* (16), pp. 433-446.
- El-Rayes, K., Ramanathan, R., and Moselhi, O. (2002), "An Object-Oriented model for Planning and Control of Housing Construction". *Journal of Construction Management and Economics* (20), pp. 201-210.

- Ezeldin, A.S. and Soliman, A. (2009), “Hybrid time-cost optimization of non-serial repetitive construction projects”, *Journal of Construction Engineering and Management*, ASCE, 135(1), pp. 42-55.
- Fan, S., and Tserng, H. (2006),” Object Oriented Scheduling for Repetitive Projects with Soft Logics” *Journal of Construction Engineering and Management*, ASCE 132(1), pp. 35–48.
- Fan, S., Sun, K., and Wang, Y. (2012), “GA optimization model for repetitive projects with soft logic”. *Automation in Construction* (21), pp. 253-261.
- French, S., Russel, A., Tran, N. (2008), “Linear Scheduling and 4D Visualization”. *Journal of Computing in Engineering*, ASCE (22), pp. 192–205.
- Friedlander, M., (2011), “Construction Project Delivery Methods: Which one is best for you?” *Illinois State Bar Association* (ISBA), Vol. (1) <https://www.isba.org/sections/construction/newsletter/2011/05/constructionprojectdeliverymethods> (accessed July 2017).
- Galloway, P., (2006), “Survey of the Construction Industry Relative to the use of CPM Scheduling for Construction Projects”. *Journal of Construction Engineering and Management*, ASCE 132(7), pp. 697–711.
- Ghamifar, K. (2009). “A Decision Support System for Project Delivery Method Selection in the Transit Industry”. Ph.D. dissertation, Northeastern University Boston, Massachusetts.
- Goftar, V., Al asmar, M., and Bingham, E. (2014), “A Meta-Analysis of Literature Comparing Project Performance between Design-Build (DB) and Design-Bid-Build (DBB) Delivery Systems”. *Construction Research Congress 2014*, ASCE, pp. 1389-1398.
- Goldberg, D. E. (1989). “Genetic Algorithms in Search, Optimization, and Machine Learning”. Addison -Wesley, Reading, Mass.
- Gould, F. (2005). “Managing the Construction Process”. Pearson, Prentice Hall, Upper Saddle River, NJ, USA



- Hale, D., Shrestha, P., Gibson, E., and Migliaccio, G. (2009), "Empirical Comparison of Design/Build and Design/Bid/Build Project Delivery Methods". *Journal of Construction Engineering and Management*, ASCE, 135(7), pp. 579-587.
- Halpin, D., and Woodhead, R. (1998), "Construction Management" 2<sup>nd</sup> ed., John Wiley & Sons.
- Hanna, A., (2012), "Using the Earned Value Management System to Improve Electrical Project Control". *Journal of Construction and Engineering Management*, ASCE (138), pp. 449-457.
- Harmelink, D. (1995), "Linear scheduling model: the development of a linear scheduling model with micro computer applications for highway construction project control." PhD thesis, Iowa State Univ., Ames, Iowa
- Harmelink, D. (2001), "Linear Scheduling Model: Float Characteristics". *Journal of Construction Engineering and Management*, ASCE, 127(4), pp. 255-260.
- Harmelink, D., and Rowings, J. (1998), "Linear Scheduling Model: Development of Controlling Activity Path". *Journal of Construction Engineering and Management*, ASCE, 124(4), pp. 263-268.
- Harris, F., and McCaffer, R. (1989), "Modern Construction Management". 3<sup>rd</sup> ed., BSP Professional Books, Oxford, U.K.
- Harris, F., and Ioannou, P. (1998), "Scheduling Projects with Repeating Activities". *Journal of Construction Engineering and Management*, ASCE, 124(4), pp. 269-278.
- Hassanein, A., and Moselhi, O. (2004), "Planning and Scheduling Highway Construction". *Journal of Construction and Management*, ASCE, 130(5), pp. 638-646.
- Hastak, M., Cui, Q., Safi, B., Gokhale, S. (2005), "A Decision Support System for Infrastructure Rehabilitation Planning". *Proceedings of the International Conference on Computing in Civil Engineering*, ASCE, pp. 1811-1820.

- Hawkins, C. V. (2007), "Assessing CPM scheduling software for the small to mid-size construction firm." Master's thesis, Faculty of the Graduate School of the University of Maryland, College Park, Maryland.
- Hayri, H., and El-Rayes, K., (2006), "Optimal Planning and Scheduling for Repetitive Construction Projects". *Journal of Construction and Management*, ASCE, 22(1), pp. 11-19
- Hayri, H., El-Rayes, K., El-Mashalehi, M. (2009), "Automated trade-off between time and cost in planning repetitive construction projects". *Construction Management and Economics* (27), pp. 749–761.
- Hegazy, T. (1999) "Optimization of construction time-cost trade-off analysis using genetic algorithms". *Canadian Journal of Civil Engineering* (26), pp. 685-697.
- Hegazy, T. (2002), "Computer-Based Construction Project Management". Prentice Hall, Upper Saddle River, NJ, USA.
- Hegazy, T. (2006), "Computrizaed System for Efficient Delivery of Infrastructure Maintenance/Repair Programs". *Journal of Construction and Engineering Management*". ASCE, 132(1), pp. 26-34.
- Hegazy, and Abdel-Monem, M. (2012), "Email-Based System for Documenting Construction As-Built Details". *Journal of Automation in Construction*, (24), pp. 130-137.
- Hegazy, T., Abdel-Monem, M and Saad, D. (2014), "Framework for enhanced progress tracking and control of linear projects". *Journal of Engineering, Construction and Architectural Management*, (21), pp. 94-110.
- Hegazy, T., Attalla, M., Hayter, L., Penny, S. (2008), "Ultra mobile computer system for accurate and speedy inspection of buildings". *Canadian Society of Civil Engineering proceedings*, pp. 456-464.
- Hegazy, T., Elhakeem, A., and Elbeltagi, E. (2004), "Distributed scheduling model for infrastructure networks." *J. Construction Engineering and Management*, ASCE, 130(2), pp. 160-167.

- Hegazy, T., and Kamarah, E. (2008), “Efficient repetitive scheduling for high-rise construction”. *Journal of Construction and Engineering Management*, ASCE, 34(4), pp. 253–264.
- Hegazy, T. and Menesi, W. (2012a), “Enhancing the critical path segments scheduling technique for project control”. *Canadian Journal of Civil Engineering*, 39(10), pp. 968-977.
- Hegazy, T. and Menesi, W. (2012b),” Heuristic Method for Satisfying Both Deadlines and Resource Constraints”. *Journal of Construction Engineering and Management*, ASCE, 138(6), pp. 688–696.
- Hegazy, T., and Menesi, W. (2010) "Critical Path Segments (CPS) scheduling technique". *Journal of Construction Engineering and Management*, ASCE, 36(10), pp. 1078-1085.
- Hegazy, T., Petzold, K., (2003), "Genetic optimization for dynamic project control", *Journal of Construction Engineering and Management*, ASCE 129 (4), pp. 396–404.
- Hegazy, T., and Wassef, N. (2001). “Cost Optimization in Projects with Repetitive Nonseial Activities.” *Journal of Construction Engineering and Management*, ASCE, 127(3), pp. 183-191
- Huang, Y., Zou, X., and Zhang, L. (2016). “Genetic Algorithm–Based Method for the Deadline Problem in Repetitive Construction Projects Considering Soft Logic” *Journal of Management in Engineering*. ASCE, 32(4), pp. 1-9
- Hwang, S., and Liu, L., (2005), “Proactive Project Control using Productivity Data and Time Series Analysis” *Proceedings of the International Conference on Computing in Civil Engineering*, pp. 1925-1935.
- Ibbs, C., Kwak, H., NG, T., and Odabasi, A. (2003), “Project Delivery Systems and Project Change: Quantitative Analysis”. *Journal of Construction Engineering and Management*, ASCE, 29(4), pp. 382-387.
- Ipsilandis, P.G, “Multi-objective Linear Programming Model for Scheduling Linear Repetitive Projects” *Journal of Construction Engineering and Management*, ASCE, 133(6), pp. 417-424.

- Issa, M. H., Attalla, M., Rankin, J. H. and Christian, A. J. (2010). "Detailed analysis of electricity, water, and gas consumption quantities and cost in Toronto's public schools". *Canadian Journal of Civil Engineering*, Vol 37, pp. 25-36.
- Jarkas, A., M., (2016) "Learning effect on labour productivity of repetitive concrete masonry blockwork: Fact or fable?". *International Journal of Productivity and Performance Management*, 65 (8), pp. 1075-1090.
- Johnston, D. W. (1981), "Linear scheduling method for highway construction". *Journal of Construction Division*, ASCE, 107(2), pp.247-26.
- Jazayeri, E., and Pajouhi, H., (2017), "Relationship between Construction Project Delivery Methods and Project Performance". *International Journal of Engineering Science and Computing*, IJESC17(6), pp. 13615-13622.
- Kamariah, E. and Hegazy, T. (2017), "Effective Repetitive Scheduling for Scattered Rehabilitation Projects" *Proceedings Canadian Society of Civil Engineering*. CON42.
- Kandil, A, and El-Rayes, K. (2005), "Parallel Computing Framework for Optimizing Construction Planning in Large Scale Projects". *Journal of Computing in Civil Engineering*, ASCE, 19 (3), pp. 304-312.
- Kang, L., Park, C., and Lee, B. (2001). "Optimal Schedule for Multiple Repetitive Construction Process" *Journal of Construction Engineering and Management*, ASCE, 127(5), pp. 382-390.
- Kelleher, A. (2004). "An investigation of the expanding role of the critical path method by ENR's top 400 contractors." Master's thesis, Faculty of Virginia Polytechnic Institute and State University, Blacksburg, Va.
- Khanh, H. and Kim, S. (2014), "Determining labor productivity diagram in high-rise building using straight-line model", *KSCE Journal of Civil Engineering*, Vol. 18 No. 4, pp. 898-908.
- Konchar, M., and Sanvido, V. (1998). "Comparison of U.S. Project Delivery Systems". *Journal of Construction Engineering and Management*, ASCE, 124(6), pp. 435-444.

- Laramee, J. (1983). "A Planning and Scheduling System for High-Rise Building Construction." Master's Thesis, Center for Building Studies, Concordia University, Montreal, Canada.
- Leu, S. S. and Lin Y. C., (2008). "Project Performance Evaluation Based on Statistical Process Control Techniques ". *Journal of Construction Engineering and Management*, ASCE, 134 (10), pp. 813–819.
- Leu, S. and Yang, C. (1999). "GA-Based Multi-Criteria Optimal Model For Construction Scheduling." *Journal of Construction Engineering and Management*, ASCE, 125(6), pp. 420-427.
- Li, H., and Love, P. (1997). "Using Machine Learning and GA to Solve Time-Cost Trade-Off Problems". *Journal of Construction Engineering and Management*, ASCE, 123(3), pp. 233-237.
- Li, J (2004). "Web-Based Integrated Project Control". PhD Thesis, Department of Building, Civil and Environmental Engineering, Concordia University, Montreal, Canada.
- Liang, X., Lu, M., and Zhang, J. P. (2011). On-site visualization of building component erection enabled by integration of four-dimensional modeling and automated surveying. *Journal of Automation in Construction*, 20(1), pp. 236-246.
- Liao, C., and Tseng, P. (2010)." Influential factors of VoIP adoption of top 500 export-import enterprises in Taiwan. *Journal of Contemporary Management Research*, 6(1), pp. 11-28.
- Liu, B., Huo, T., Liang, Y., Sun, Y., and Hu, X., (2016). "Key Factors of Project Characteristics Affecting Project Delivery System Decision Making in the Chinese Construction Industry: Case Study Using Chinese Data Based on Rough Set Theory". *Journal of Professional Issues in Engineering Education and Practice*, ASCE,142(4): 05016003-1-10.
- Lipke, W., (2003) "Schedule is different". *The Measurable News* (Summer), pp. 31–34.
- Lipke, W., Zwikael, O., Henderson, K., Anbari, F.T., (2009) "Prediction of project outcome: the application of statistical methods to earned value management and earned schedule performance indexes". *International Journal of Project Management* (27), pp. 400–407.

- Liu, S., Shih, K., (2009). "Construction rescheduling based on a manufacturing rescheduling framework," *Automation in Construction* (18), pp. 715–723.
- Liu, S., Wang, C., (2007). "Optimization model for resource assignment problems of linear construction projects," *Automation in Construction* (16), pp. 460–473.
- Long, L. and Ohsato, A. (2009). "A genetic algorithm-based method for scheduling repetitive construction projects" *Automation in Construction*, (18), pp. 499–511.
- Lumdson, P.(1968)"The Line of Balance Method." Pergamon Press, London U.K
- Lyer, K.C., and Jha, K.N. (2006). "Critical Factors Affecting Schedule Performance: Evidence from Indian Construction Projects". *Journal of Construction Engineering and Management*, ASCE, 32(8), pp. 871–881.
- Mahdi, I., and Alreshaid, K., (2005). "Decision Support System for Selecting the Proper Project Delivery Method using Analytical Hierarchy Process (AHP)". *International Journal of Project Management* (23), pp. 564–572.
- Mafakheri, F., Slezak, D., and Nasiri, F. (2007). "Project Delivery System Selection under Uncertainty: Multicriteria Multilevel Decision Aid Model". *Journal of Management in Engineering*, ASCE, 23(4), pp. 200-206.
- Malyusz, L., (2016), "Learning Curve Effect on Project Scheduling". Creative Construction Conference 2016, Budapest University of Technology and Economics, *Procedia Engineering* 164 (2016), pp. 90-97.
- Mattila, K., and Abraham, D. (1998). "Resource leveling of linear schedules using integer linear programming." *Journal of Construction Engineering and Management*, ASCE, 129(1), pp. 56–54.
- Mattilla, K., and Park., A. (2003)." Comparison of Linear Scheduling and Repetitive Scheduling Method". *Journal of Construction Engineering and Management*, ASCE, 135(9), pp. 863-873.
- McMaster University-Asset Management Plan (2012). ([www.mcmaster.ca](http://www.mcmaster.ca)) (accessed 2016)

- Menesi, W., Golzarpoor, B., Hegazy, T.,(2013), " Fast and Near-Optimum Schedule Optimization for Large-Scale Projects". *Journal of Construction Engineering and Management*, ASCE, 139(9), pp. 1117-1124.
- Minchin, E. (2009). "Fall and Rise of the Largest Construction Manager-at-Risk Transportation Construction Project Ever". *Journal of Construction Engineering and Management*, ASCE, 139(9), pp. 930-938.
- Moselhi, O. and El-Rayes, K. (1993). "Scheduling of Repetitive Projects with Cost Optimization." *Journal of Construction Engineering and Management*, ASCE, 119(4), pp. 681-697.
- Moselhi, O, LI, J, and Elkass, S. (2004). "Web-based Integrated Project Control System" *Construction Management and Economics* (22), pp. 35-46.
- Mubarak, S. (2005). "Construction Project Scheduling and Control." Prentice Hall, Upper Saddle River, NJ, USA
- Narbaev,T., and De Marco, A., (2014), "Combination of Growth Model and Earned Schedule to Forecast Project Cost at Completion". *Journal of Construction Engineering and Management*, ASCE, 140(1), pp. 1-10.
- Navon, R. (2007). "Research in automated measurement of project performance indicators" *Journal of Automation in Construction*, 16(2), pp. 176-188.
- Nunnally, S. (1998). "Construction Methods and Management." 4th ed, Prentice Hall, Upper Saddle River, NJ, USA.
- Olawale, Y. and Sun, M., (2010). " Cost and Time Control of Construction projects: Inhibiting Factors and Mitigating Measures in Practice". *Construction Management and Economics* (28), pp. 509-526.
- Ontario Ministry of Education -School Facility Condition Report Data (2016).  
[www.edu.gov.on.ca](http://www.edu.gov.on.ca)

- Orabi, W. and El-Rayes, K. (2012). “Optimizing the Rehabilitation Efforts of Aging Transportation Networks”. *Journal of Construction Engineering and Management*, ASCE, 138(4), pp. 529-539.
- Oyetunji, A., and Anderson, S., (2006). “Relative Effectiveness of Project Delivery and Contract Strategies” *Journal of Construction Engineering and Management*, ASCE, 132(1), pp. 3-13.
- Paik, J., Miller, V., Mollaglu, S., and Sun, W. “Interorganizational Projects: Reexamining Innovation Implementation via IPD Cases”. *Journal of Management in Engineering*, ASCE, 33(5), pp. 1-15.
- Pajares, J., López-Paredes, A., “An extension of the EVM analysis for project monitoring: The Cost Control Index and the Schedule Control Index”. *International Journal of Project Management*, (29) pp. 615–621.
- Parker, H., and Oglesby, C. (1972), “Methods Improvement for Construction Managers” McGraw-Hill Series in Construction Engineering and Management.
- Pena-Mora, F., Dwivedi, G. (2002), “Multiple device collaborative and real time analysis system for project management in civil engineering”. *Journal of computing in Civil Engineering*, ASCE, 16(1), pp. 22-38.
- PMBOK® Guide, (2013) “A Guide to the Project Management Body of Knowledge” Fifth Edition.
- Poku, S., Arditi, D. (2006), “Construction Scheduling and Progress Control Using Geographical Information systems”. *Journal of Computing in Civil Engineering*, 20(5), pp. 351-360.
- Rajos, E., and Kell, I. (2008), “Comparative Analysis of Project Delivery Systems Cost Performance in Pacific Northwest Public Schools” *Journal of Construction Engineering and Management*, ASCE, 134(6), pp. 387-397.



- Ramachandra, T., Geekiyanage, D., and Perera, L. (2017). "Study on the Application of Economies of Scale in the Construction Industry: The Sri Lankan Perspective". *The 6th World Construction Symposium 2017: What's New and What's Next in the Built Environment Sustainability Agenda?* Colombo, Sri Lanka.
- Rashedi, R. and Hegazy, T. (2016). "Holistic Analysis of Infrastructure Deterioration and Rehabilitation Using System Dynamics". *Journal of Infrastructure Systems*, ASCE, 22(1), pp. 1-10.
- Reda, R. (1990). "RPM: Repetitive Project Modeling." *Journal of Construction Engineering and Management*, ASCE, 116(2), pp. 316-330.
- Reinhardt, J., Akinci, B., and Garrett, J. H. (2004). Navigational models for computer supported project management tasks on construction sites. *Journal of Computing in Civil Engineering*, 18(4), pp. 281-290.
- Repas, K., De la Garza J., Thabet, W., (2000). "Mobile schedule tracking technology at the jobsite" *Precedence of ASCE Construction Congress*, Orlando, Florida, USA, pp. 204-213.
- Riley, D., and Sanvido, V. (1997). "Space planning for mechanical, electrical, plumbing, and fire protection trades in multistory buildings construction". *Precedence of the ASCE Construction Congress*, New York, pp. 102-109.
- Riley, D., Diller, B. and Kerr, D. (2005). "Effects of Delivery Systems on Change Order Size and Frequency in Mechanical Construction" *Journal of Construction Engineering and Management*, ASCE, 131(9), pp. 953-962.
- Rosner, J., Thal, A., and West, C., (2009). " Analysis of the Design-Build Delivery Method in Air Force Construction Projects". *Journal of Construction Engineering and Management*, ASCE, 135(8), pp. 710-717.
- Russell, A. and Caselton, W. (1988) "Extensions to Linear Scheduling Optimization." *Journal of Construction Engineering and Management*, ASCE, 114(1), pp. 36-52.

- Scott, S., and Assadi, S. (1999). "A survey of the site records kept by construction supervisors". *Journal of Construction Management and Economics*, 17(3), pp. 375-382.
- Selinger, S. (1980). "Construction Planning for Linear Projects." *Journal of the Construction Division*, ASCE, 106(2), pp. 195-205.
- Senior, B. and Halpin, D. (1998). "Simplified Simulation System for Construction Projects". *Journal of Construction Engineering and Management*, ASCE, 124(1), pp. 72-81.
- Senouci, A., and Eldin, N. (2004). "Use of Genetic Algorithm in Resource Scheduling of Construction Projects." *Journal of Construction Engineering and Management*, ASCE, 130(6), pp. 869-877.
- Senouci, A. and Eldin, N. (1996). "A Time-Cost Trade-Off Algorithm for Non-Serial Linear Projects." *Canadian Journal of Civil Engineering*, 23, pp. 134-149.
- Senouci, A., Alserraj, A., Gunduz, M., and Eldin, N. (2016). "Analysis of Change Orders in Qatari Construction Projects". *International Journal of Construction Management*, DOI: 10.1080/15623599.2016.1211973
- Shahid, S., and Froese, T. (1998). "Project management information control systems". *Canadian Journal of Civil Engineering*, 25(4), pp. 735-754.
- Shaked, O. and Warszawski, A. (1995). "Knowledge-Base System for Construction Planning of High-Rise Buildings." *Journal of Construction Engineering and Management*, ASCE, 121(2), pp. 172-182.
- Shrestha, P., Connor, J., Gibson, E. (2012). "Performance Comparison of Large Design-Build and Design-Bid-Build Highway Projects" *Journal of Construction Engineering and Management*, ASCE, 138(1), pp. 1-13.
- Siemiatycki, M., (2015) "Cost Overruns on Infrastructure Projects: Patterns, Causes, and Cures". Institute of Municipal Finance and Governance (IMFG), Munk School of Global Affairs, University of Toronto.

- Son, H., and Kim, C. (2010). "3D structural component recognition and modelling method using colour and 3D data for construction progress monitoring". *Journal of Automation in Construction*, 19(7), pp. 844-854.
- Srour, F.J., Kiomjian, D., Srour, I., (2016), "Learning Curves in Construction: A Critical Review and New Model". *Journal of Construction Engineering and Management*, ASCE, 142(4), pp. 1-5.
- Stumpf, G.R. (2000), "Schedule delay analysis", *Cost Engineering Journal*, AACE International, 42(7), pp. 32-43.
- Su, Y., and Lucko, G., (2016). "Linear scheduling with multiple crews based on line-of-balance and productivity scheduling method with singularity functions". *Journal Automation in Construction* (70), pp. 38-50.
- Suhail, S. and Neale, R. (1994). "CPM/LOB: New Methodology to Integrate CPM and Line of Balance". *Journal of Construction Engineering and Management*, ASCE, 120(3), pp. 667-684.
- Sullivan, J., El-Asmar, M., and Chalhoub, J. (2017). "Two Decades of Performance Comparisons for Design-Build, Construction Manager at Risk, and Design-Bid-Build: Quantitative Analysis of the State of Knowledge on Project Cost, Schedule, and Quality". *Journal of Construction Engineering and Management*, ASCE, 143(6), pp. 1-11.
- Tang, Y., Liu, R., and Sun Q., (2014). "Schedule Control model for Linear Projects based on Linear Scheduling Method and Constraint Programming", *Automation in Construction* (37), pp. 22-37.
- Tang, Y., Liu, R., and Sun Q. (2014). "Two-Stage Scheduling Model for Resource Leveling of Linear Projects" *Journal of Construction Engineering and Management*, ASCE, 140(7), pp. 1-11.
- Tang, P. and Mukherjee, A. (2012) "Activity Criticality Index Assessment Using Critical Path Segment Technique and Interactive Simulations". *Construction Research Congress*, ASCE, pp. 1094-1103.

- Thabet, W. and Beliveau, Y. (1997). "ScaRC: Space-Constrained Resource-Constrained Scheduling System." *Journal of Computing in Civil Engineering*, 11(1), pp. 48-59.
- Thabet, W. and Beliveau, Y. (1994). "HVLS: Horizontal and Vertical Logic Scheduling for Multistory Projects". *Journal of Construction Engineering and Management*, ASCE, 120 (4), pp. 875-892.
- TILOS Linear Project, available at: [www.tilos.org](http://www.tilos.org) (accessed September 2015).
- Tokdemir, O., Arditi D., and Balcick C., (2006) "ALISS: Advanced Linear Scheduling System". *Construction Management and Economics* (24), pp. 1235-1267.
- Toronto District School Board (TDSB) website: [www.tdsb.on.ca](http://www.tdsb.on.ca) (accessed from September 2015 to October 2018).
- Touran, A., Gransberg, D., Molenaar, K., and Ghavamifar, K., (2009). "A Decision Support System for Project Delivery Method Selection in Transit," *Journal of the Transportation Research Board, National Academies*, Transportation Research Record No. 2111, pp. 148-157.
- Touran, A., Gransberg, D., Molenaar, K., and Ghavamifar, K., (2011). " Selection of Project Delivery Method in Transit: Drivers and Objectives". *Journal of Management in Engineering*, ASCE, 27(1), pp. 21-27
- Vandevoorde, S., Vanhoucke, M., (2006) "A comparison of different project duration forecasting methods using earned value metrics," *International Journal of Project Management* (24), pp. 289–302.
- Vanhoucke, M., (2011) "Measuring the efficiency of project control using fictitious and empirical project data," *International Journal of Project Management* 30(2), pp. 252–263.
- Vico Software Integrating Construction, : [www.vicosoftware.com](http://www.vicosoftware.com) (accessed September 2015).
- Wang, C and Huang, Y., (1998) "Controlling activity interval times in LOB scheduling" *Journal of Construction Management and Economics*, (16), pp. 5-16.

- Williams, G. H. (2003). "An evaluation of public construction contracting methods for the public building sector in Oregon using data envelopment analysis." Ph.D. dissertation, Portland State Univ., Portland, OR.
- Wellington Project Management, (2017). "The State of Project Management: Annual Survey 2017". ([www.wellington.co.uk](http://www.wellington.co.uk))
- Yang, T. and Ioannou, P. (2004). "Scheduling System with Focus on Practical Concerns in Repetitive Projects." *Journal of Construction Management and Economics*, (22), pp. 619-630.
- Zhang, L. and Qi, L. , (2012) "Controlling Path and Controlling Segment Analysis Repetitive Scheduling Method". *Journal of Construction Engineering and Management*, ASCE, 138(11), pp. 1341-1345.
- Zheng, D., NG, T., and Kumaraswamy, M. (2004). "Applying a Genetic Algorithm-Based Multiobjective Approach for Time-Cost Optimization". *Journal of Construction Engineering and Management*, ASCE,130(2), pp. 168-176.