

Ecological Interface Design for Turbine
Secondary Systems in a Nuclear Power Plant:
Effects on Operator Situation Awareness

by

Jordanna Kwok

A thesis
presented to the University of Waterloo
in fulfillment of the
thesis requirement for the degree of
Master of Applied Science
in
Systems Design Engineering

Waterloo, Ontario, Canada, 2007

© Jordanna Kwok, 2007

AUTHOR'S DECLARATION FOR ELECTRONIC SUBMISSION OF A THESIS

I hereby declare that I am the sole author of this thesis. This is a true copy of the thesis, including any required final revisions, as accepted by my examiners.

I understand that my thesis may be made electronically available to the public.

Abstract

Investigations into past accidents at nuclear power generating facilities such as that of Three Mile Island have identified human factors as one of the foremost critical aspects in plant safety. Errors resulting from limitations in human information processing are of particular concern for human-machine interfaces (HMI) in plant control rooms. This project examines the application of Ecological Interface Design (EID) in HMI information displays and the effects on operator situation awareness (SA) for turbine secondary systems based on the Swedish Forsmark 3 boiling-water reactor nuclear power plant. A work domain analysis was performed on the turbine secondary systems yielding part-whole decomposition and abstraction hierarchy models. Information display requirements were subsequently extracted from the models. The resulting EID information displays were implemented in a full-scope simulator and evaluated with six licensed operating crews from the Forsmark 3 plant. Three measures were used to examine SA: self-rated bias, Halden Open Probe Elicitation (HOPE), and Situation Awareness Control Room Inventory (SACRI). The data analysis revealed that operators achieved moderate to good SA; operators unfamiliar with EID information displays were able to develop and maintain comparable levels of SA to operators using traditional forms of single sensor-single indicator (SS-SI) information displays. With sufficient training and experience, operator SA is expected to benefit from the knowledge-based visual elements in the EID information displays. This project was researched in conjunction with the Cognitive Engineering Laboratory at the University of Toronto and the Institute for Energy Technology (IFE) in Halden, Norway.

Acknowledgements

I would like to thank Dr. Catherine Burns for her supervision in this study and, in particular, her guidance and infinite patience during the past few years on a variety of projects. In addition, I would like to thank my thesis readers Dr. Olga Vechtomova and Dr. Jonathan Kofman for their support and feedback. This project was made possible with the collaboration of a number of individuals: Dr. Greg Jamieson and Nathan Lau (of Cognitive Engineering Laboratory, University of Toronto), as well as Gyrð Skraaning Jr., Robin Welch, Øystein Veland, and Christer Nihlwing (of the Norwegian Institute for Energy Technology, IFE). The implementation and experimentation crew at IFE for the HAMMLAB projects allowed for the evaluation process to run smoothly and efficiently. The feedback provided by the participating Swedish Forsmark 3 operating crews was greatly appreciated. I would also like to express gratitude to Jon Kvalem at IFE for making my stay in Halden, Norway both productive and enjoyable. Funding for the project was provided by NSERC Special Research Opportunities.

Table of Contents

Abstract.....	iii
Acknowledgements.....	iv
Table of Contents.....	v
List of Figures.....	vii
List of Tables.....	ix
Chapter 1: Introduction.....	1
1.1 Overview.....	2
1.2 Scope and Objectives.....	3
1.3 Contributions.....	4
1.4 Thesis Organisation.....	4
Chapter 2: Background Review.....	5
2.1 Halden Reactor Project.....	5
2.2 Ecological Interface Design.....	7
2.2.1 Abstraction Hierarchy.....	9
2.2.2 Skills, Rules, and Knowledge Framework.....	10
2.2.3 Applications.....	11
2.3 Situation Awareness.....	13
2.3.1 Measurement.....	16
2.3.1.1 Halden Open Probe Elicitation (HOPE).....	17
2.3.1.2 Situation Awareness Global Assessment Technique (SAGAT).....	18
2.3.1.3 SACRI.....	19
Chapter 3: Ecological Interface Design for Turbine Secondary Systems.....	21
3.1 System Description and Boundary.....	21
3.2 Work Domain Analysis.....	23
3.2.1 Part-Whole Decomposition.....	23
3.2.2 Abstraction Hierarchy.....	31
3.3 Information Display Design.....	34
3.3.1 Information Analysis.....	34
3.3.2 Graphical Forms.....	38
3.3.2.1 Design at the Functional Purpose Level.....	39
3.3.2.2 Design at the Abstract Function Level.....	42
3.3.2.3 Design at the Generalized Function Level.....	44
3.3.2.4 Design at the Physical Function and Physical Form Levels.....	47
3.3.3 Graphical Organisation.....	49
Chapter 4: Methodology for Evaluating Ecological Interface Design and Situation Awareness.....	54
4.1 Participants.....	54
4.2 Experimental Environment.....	55
4.3 Experimental Design.....	56

4.4 Hypotheses.....	58
4.5 Power Analysis	60
4.6 Procedure	62
Chapter 5: Data Analysis and Results.....	64
5.1 Demographics	64
5.2 Self-Rated Bias	65
5.3 Halden Open Probe Elicitation (HOPE).....	67
5.4 Situation Awareness Control Room Inventory (SACRI).....	69
Chapter 6: Discussion	76
6.1 Hypotheses Verification.....	76
6.1.1 Main Effect: Interface Type.....	77
6.1.2 Main Effect: Scenario Type.....	78
6.1.3 Interaction Effect: Interface Type and Scenario Type.....	79
6.1.4 Main Effect: Scenario Period.....	81
6.2 Contributions to Ecological Interface Design and Situation Awareness	82
6.3 Limitations	84
Chapter 7: Summary and Recommendations.....	89
References.....	91
Appendix A.....	96
Appendix B.....	100
Appendix C.....	101
Appendix D.....	107
Appendix E.....	112
Appendix F.....	114
Appendix G.....	117
Appendix H.....	119
Appendix I.....	121
Appendix J.....	158
Appendix K.....	166

List of Figures

Figure 1: Modernising the Forsmark 3 Boiling Water Reactor Nuclear Power Control Room.....	1
Figure 2: HAMMLAB Simulated Control Room Environment.....	6
Figure 3: Turbine, Condenser, and Feedwater System Boundaries.....	23
Figure 4: Part-Whole Model of the Turbine System at the System (Black Box) Level ...	24
Figure 5: Part-Whole Model of the Turbine System at the Subsystem Level	26
Figure 6: Part-Whole Model of the Main Steam (421) Subsystem	27
Figure 7: Part-Whole Model of the Steam Reheat (422) Subsystem.....	28
Figure 8: Part-Whole Model of the Steam Valves (311) Subsystem.....	29
Figure 9: Part-Whole Model of the Seal and Leakage (424) Subsystem.....	30
Figure 10: Abstraction Hierarchy at Part-Whole System Level	33
Figure 13: Reactor Pressure Graphic at the Functional Purpose Level	40
Figure 14: Valve Position Graphic (Polar Star) at the Functional Purpose Level	40
Figure 15: Valve Position Graphic (Grid) at the Functional Purpose Level.....	40
Figure 16: Turbine Speed Graphic at Functional Purpose Level.....	41
Figure 17: Generator Output Graphic at Functional Purpose Level	41
Figure 18: Mass Balance Graphic at Abstract Function Level	43
Figure 19: Mollier Diagram of Typical Energy Flow in Turbine System (Ontario Power Generation, 1988)	44
Figure 20: Energy Flow Profile at Abstract Function Level.....	44
Figure 21: Temperature and Pressure Profiles at Abstract Function Level	45
Figure 22: Traditional Sychroscope Indicator (Canadian Nuclear Safety Commission, 2003)	46
Figure 23: Grid Synchronisation Graphic at Generalized Function Level	46
Figure 24: Voltage Conversion Graphic at Generalized Function Level	46
Figure 25: Tank Graphics at Physical Function Level.....	47
Figure 26: Turbine Vibration Graphic at Physical Function Level	48
Figure 27: Main Steam Subsystem Display in the Turbine System	50
Figure 28: Steam Reheat Subsystem Display in the Turbine System.....	51
Figure 29: Generator Subsystem Display in the Turbine System.....	52
Figure 30: HAMMLAB Control Room Layout.....	55
Figure 31: HAMMLAB Observation Gallery.....	55
Figure 32: Mean Self-Rated Bias.....	67
Figure 33: Mean HOPE Level of Understanding	68
Figure 34: Mean SACRI Sensitivity (A') Scores	70
Figure 35: Mean SACRI Response Bias (R:S) Scores	72
Figure 36: Scenario Type and Scenario Period A' Interaction Effect	73
Figure 37: Interface Type and Scenario Type R:S Interaction Effect	75

Figure 38: Scenario Type and Scenario Period R:S Interaction Effect	75
Figure 39: Mimic Display of Main Steam (421) Subsystem	96
Figure 40: Mimic Display of Steam Reheat (422) Subsystem	97
Figure 41: Mimic Display of Turbine (403) Components	98
Figure 42: Mimic Display of Generator (615) Components.....	99
Figure 43: Material Colour Legend (Adapated from Lau, 2006)	100
Figure 44: Part-Whole Model of the Governing Oil (452) Subsystem.....	101
Figure 50: Steam Related Subsystems of Turbine Secondary Systems.....	112
Figure 51: Electrical Related Subsystems of Turbine Secondary Systems	113
Figure 52: Screenshot of Main Steam Subsystem in Turbine Secondary Systems	114
Figure 53: Screenshot of Steam Reheat Subsystem in Turbine Secondary Systems.....	115
Figure 54: Screenshot of Generator Subsystem in Turbine Secondary Systems.....	116
Figure 55: Experiment Screen Layouts.....	119
Figure 56: Screen Positioning in Control Room (Skraaning Jr., 2005).....	120

List of Tables

Table 1: Extracted Variable at the Abstract Function Level.....	37
Table 2: Independent Variables	57
Table 3: Dependent Variables.....	57
Table 4: Scenario Descriptions.....	58
Table 5: Summary of Hypotheses.....	60
Table 6: P-Value Interpretations for Power Analysis.....	61
Table 7: Power Estimates for RBF-322 (Skraaning Jr., Nihlwing, Welch, & Veland, 2005a)	61
Table 8: Experiment Run Plan (Skraaning Jr., Nihlwing, Welch, & Veland, 2005a)	63
Table 9: Demographics Results	65
Table 10: Self-Rated Bias Summary.....	66
Table 11: Self-Rated Bias ANOVA.....	66
Table 12: HOPE Level of Understanding Summary	68
Table 13: HOPE Level of Understanding ANOVA	69
Table 14: SACRI Sensitivity (A') Summary	70
Table 15: SACRI Response Bias (R:S) Summary	71
Table 16: SACRI Sensitivity (A') ANOVA	73
Table 17: SACRI Response Bias (R:S) ANOVA.....	74
Table 18: System Number Legend	100
Table 19: Condensed Information Requirements for Turbine Secondary Systems at System Level.....	107
Table 20: Condensed Information Requirements for Turbine Secondary Systems at Subsystem Level	109

Chapter 1

Introduction

As new technologies are introduced into the nuclear industry, there is increasing interest in replacing existing hardwired monitoring systems in nuclear power plant control rooms with innovative human-machine interface (HMI) information displays (see Figure 1). However, it is important that the next-generation operator support systems are designed to overcome limitations in human information processing that are crucial to nuclear power plant safety. The design of interfaces with which users interact can essentially enhance or restrict perceptual and cognitive processes ranging from signal detection to decision making; such processes directly influence operator performance (Wickens & Hollands, 2000) and situation awareness (Endsley, 1995). A variety of design strategies and guidelines for nuclear power plant operator support systems have been developed over the years to improve overall safety and reliability.



Figure 1: Modernising the Forsmark 3 Boiling Water Reactor Nuclear Power Control Room

Ecological Interface Design (EID) is a design framework for HMI information displays that has been shown in existing studies to support operator performance for both anticipated and unanticipated events, which are often precursors to serious accidents (Vicente, 1999a). Although not substantiated by any experimental data thus far, the fundamental principles of EID suggest that there is also some level of support for operator situation awareness. This thesis will examine EID information displays in next-generation nuclear power plant control rooms and its effects on operator situation awareness.

1.1 Overview

Recent field studies of operator monitoring strategies in nuclear power plant control rooms have revealed that performance is limited by the need to identify relevant information against a noisy background (Mumaw, Roth, Vicente, & Burns, 2000). Much of the information related to the plant process is presented to the operators via a human-machine interface (HMI). In many existing nuclear power plants, operators rely primarily on HMIs that consist of hardwired indicators and alarms to determine the state of the plant. Secondary sources of information include status logs, maintenance records, and field personnel. Given the large amount of information that needs to be processed by the operators, human information processing limitations become apparent: attention, perception, problem solving, and decision making are some of the abilities affected.

Errors resulting from design deficiencies in the HMI at the Three Mile Island nuclear facility contributed significantly to the accident (Kemeny, 1979). It was found that a major pressure relief valve indicator failed to reflect the actual position of the valve. As well, no indicator existed to show the exact water level in the reactor core. Various design guidelines have been established as a result of the Three Mile Island incident. With the introduction of modern display technologies (e.g. LCD monitors, large-screen projectors) in existing nuclear power plant control rooms, there is growing interest in the design of HMI information displays. It is hoped that the displays will be able to convey relevant information needed by operators in a more efficient and reliable manner than previously with hardwired monitoring systems. In addition to design

guidelines, a number of design methodologies for HMIs have been developed over the last decade in order to overcome a variety of known human performance limitations and improve safety. Ecological Interface Design (EID) is one such design framework that aims to support operator information processing in safety critical situations (Vicente & Rasmussen, 1990, 1992). Of interest is to what extent EID supports operator situation awareness in anticipated and unanticipated scenarios.

1.2 Scope and Objectives

The OECD Halden Reactor Project hosted by the Norwegian Institute for Energy Technology (IFE) seeks to design and evaluate innovative operator support systems for next-generation nuclear power plant controls rooms. The University of Waterloo and the University of Toronto are collaborating with IFE to determine the practical benefits of EID in the evolving nuclear industry. In particular, the project examines the secondary non-reactor systems of the Swedish Forsmark 3 boiling water reactor nuclear power plant: turbine system, condenser system, and feedwater system. This thesis focuses on the design and evaluation of EID information displays for the turbine system portion of the plant. Note that the terms “turbine system” and “turbine secondary systems” are used interchangeably in this thesis.

Although EID information displays have previously been successfully implemented in simulator (Dinadis & Vicente, 1996) and commercial (Itoh, Sakuma, & Monta, 1995) settings, most EID implementations have not been evaluated in representative industrial settings with trained operators (Jamieson, 2002). The current study evaluates EID information displays via a state-of-the art simulated control room environment (HAMMLAB) and licensed Forsmark 3 operators. In addition to using traditional usability metrics such as task response times for evaluating the EID information displays, the study measures a relatively new concept known as situation awareness (Endsley, 1995). This thesis aims to determine whether and how EID information displays support operator situation awareness (SA); possible effects of EID on SA have not been previously investigated in formative studies.

1.3 Contributions

The contributions of this thesis are summarized as follows:

- Development of EID information displays for the turbine secondary systems of a boiling water nuclear power plant. Note that all work found in Chapter 3 is specific to the turbine secondary systems (i.e. not condenser, feedwater secondary systems) and included specifically for the purposes of this thesis (i.e. not based on prior work).
- Evaluation of EID information displays in a next-generation simulated control room environment with trained nuclear power plant operators.
- Comparison of operator SA for EID information displays vs. traditional and advanced mimic displays.
- Exploration of EID as a framework for supporting not only operator performance, but also operator SA in complex monitoring and control systems.

1.4 Thesis Organisation

The remainder of this thesis is organized as follows:

- Chapter 2 introduces the theoretical foundations of EID and SA; prior research involving the application of EID and SA in process control environments is reviewed. The chapter also provides a brief background on the OECD Halden Reactor Project.
- Chapter 3 documents the design process of EID information displays for the turbine secondary systems in the Forsmark 3 boiling water reactor nuclear power plant.
- Chapter 4 describes the experimental design used for evaluating the EID information displays with operator SA as a primary measure.
- Chapter 5 presents the results of the experiment and subsequent data analysis.
- Chapter 6 discusses the findings of the experiment, i.e. possible explanations for the results, EID as a framework for supporting operator SA, and limitations of the study.
- Chapter 7 summarizes the study and identifies future work to be done in the areas of EID and SA.

Chapter 2

Background Review

Studies involving the application of the Ecological Interface Design (EID) framework in the nuclear power plant domain are numerous. Likewise, the concept of situation awareness (SA) in nuclear power plant control rooms is discussed in an increasing number of reports. Although the theoretical foundations of EID suggest support for SA, it has not been previously investigated in formative studies. This chapter introduces the EID framework and reviews the fundamentals of SA. A brief description of the OECD Halden Reactor Project (HRP) of which this study is a part is also provided in the following section. It should be noted that discussions revolving around the validity of SA as a concept and as a measure are beyond the scope of this chapter.

2.1 Halden Reactor Project

The OECD Halden Reactor Project (HRP) is an initiative hosted by the Norwegian Institute for Energy Technology (IFE) aimed at promoting research and development in the areas of nuclear power plant safety and reliability. National organisations in 20 countries share resources to support the jointly financed programme. The programme specializes in providing solutions to extend fuel utilisation, exploring the degradation of core materials, and advancing man-machine systems. The study described in this thesis is part of a larger project aimed at designing and evaluating innovative human-machine interfaces (HMI), which falls under the latter of the three areas of research. Ecological Interface Design (EID) is one of the design approaches examined in the study and is largely a product of Canadian innovation. Because Canada does not contribute to the HRP, Canadian researchers do not have access to the findings in existing projects and are

not eligible for research funding. However, an agreement was reached with IFE for dissemination of research findings in exchange for independent funding from the NSERC Special Research Opportunity (SRO) program.

The Halden Man-Machine Laboratory (HAMMLAB) is a modern nuclear power plant simulation testbed used by HRP to study operator interaction with novel operator support systems and to develop new control room technologies (see Figure 2). The facility and its resources supported the evaluation of EID in a representative industrial environment. In this particular study, HAMMLAB's underlying simulator emulated the Swedish Forsmark 3 boiling water reactor nuclear power plant and enabled the extraction of specific process information for display purposes. The HMIs were implemented with an in-house software tool known as Picasso (now under the name ProcSee), which specializes in the design of dynamic graphical forms. A number of power plant licensees contribute to the HRP and encourage plant operators and process engineers to participate in human-subject experiments involving HMIs.



Figure 2: HAMMLAB Simulated Control Room Environment

The experiment in this project employed licensed Forsmark 3 control room operators and was conducted by highly experienced simulation specialists, process engineers, and a team of experimentalists. The evaluation of EID on such a scale was

unprecedented, costing upwards of \$1,000,000 CDN. The project itself was a collaborative effort between researchers at the University of Waterloo, University of Toronto, and IFE. Each institute focused on different areas of the system under investigation, i.e. secondary non-reactor systems: turbine system (University of Waterloo), condenser system (University of Toronto), and feedwater system (IFE). The combined results of the study will provide the industry with valuable information on the design and development of information displays for next-generation control rooms. This thesis in particular examines effects of an EID information display on operator situation awareness (SA) for the turbine secondary systems. The following sections will introduce the fundamentals of EID and SA.

2.2 Ecological Interface Design

Ecological Interface Design (EID) is a framework for designing interfaces for complex socio-technical, real-time, and systems such as nuclear power plants (Rasmussen & Vicente, 1989). EID differs from traditional user-centred based design approaches as it relies on the assertion that human behaviour is determined primarily by perceived constraints in the environment. The term “ecological” in EID originates from a school of psychology developed by Gibson (1979) known as ecological psychology. This field of psychology focuses on the human-environment relationships, in particular in relation to human perception in actual environments rather than in laboratory environments. EID borrows from ecological psychology in that the constraints of the work environment in a complex system are reflected perceptually (through an interface); therefore, affecting human behaviour.

The EID framework aims to make the constraints and complex relationships of the work environment perceptually evident (e.g. visible, audible) to the user. In essence, fewer cognitive resources would be necessary to determine whether elements in the work environment are operating within constraints. A direct and intentional result of the above is that more cognitive resources would be made available (i.e. freed) for higher cognitive activities such as problem solving and decision making, which are often required during safety-critical situations. The performance of such activities is presumed to be related to

the limitation of cognitive resources such as attention, working memory, and long-term memory (Wickens & Hollands, 2000). EID is based on two key concepts in cognitive engineering research: the Abstraction Hierarchy (AH) and the Skills, Rules, Knowledge (SRK) framework.

Due to rapid advances in technologies and growing economic demands, there is a noticeable increase in the complexity of engineering systems (Vicente, 1999a). As a result, it is becoming more and more difficult for operators and engineers to anticipate events that may occur within the systems. Unanticipated events by definition cannot be determined in advance and thus cannot be directly prevented through training, procedures, or automation. A human-machine interface (HMI) for a complex system designed based solely on known scenarios frequently loses the flexibility to support unforeseen events. System safety is often compromised by the operators' inability to adapt to new and unfamiliar situations (Vicente & Rasmussen, 1992). EID attempts to provide operators with the necessary tools and information to become active problem solvers as opposed to passive monitors. Interfaces designed following the EID framework aim to lessen mental workload when dealing with unfamiliar and unanticipated events, which are attributed to increased psychological pressure (Vicente, 1999b).

In addition to providing operators with the means to successfully manage unanticipated events, EID is also proposed for systems that require users to become experts (Burns & Hajdukiewicz, 2004). Through the use of the AH and the SRK framework, EID enables novice users to more easily acquire advanced mental models that generally take many years of experience and training to develop. Likewise, EID provides a basis for continuous learning and distributed, collaborative work (Vicente, 1999b). When faced with complex systems, it is not always possible for designers to ask operators what kinds of information they would like to see since each person understands the system at a different level (but rarely fully) and will provide very different answers. The EID framework allows designers to determine what kinds of information are required when it is not possible or feasible to ask users (Burns & Hajdukiewicz, 2004). It is not the intention of EID to replace existing design methodologies such as UCD and task analysis, but to complement them.

2.2.1 Abstraction Hierarchy

The Abstraction Hierarchy (AH) is a key tool developed by Rasmussen (1985) for carrying out the Work Domain Analysis (WDA) process in the EID framework. It is used for modelling the work environment, or more commonly referred to as the work domain, via a five-level functional decomposition. Each level of abstraction in the model is related to the next; the relationships are indicated by means-ends (i.e. how-why) links. Elements at highest level of the model define the purposes and goals of the system. Elements at the lowest levels of the model indicate and describe the physical components (i.e. equipment) of the system. It is not uncommon for a Work Domain Analysis to yield multiple AH models, each examining the system at a different level of physical detail defined using another model called the Part-Whole Hierarchy (Burns & Hajdukiewicz, 2004). During the design process, AH models are used to determine the kinds of information that should be displayed on the interfaces and how the information should be arranged.

Each level of abstraction in the AH is a complete, but unique description of the work domain:

- The *Functional Purpose* (FP) level describes the goals and purposes of the system; it is located at the top of the hierarchy. An AH typically includes more than one system goal such that the goals conflict or complement each other. The relationships between the goals indicate potential trade-offs and constraints within the work domain of the system (Burns & Hajdukiewicz, 2004).
- The *Abstract Function* (AF) level describes the underlying laws and principles that govern the goals of the system. These may be empirical laws in a physical system, judicial laws in a social system, or even economic principles in a commercial system. In general, the laws and principles focus on things that need to be conserved or that flow through the system such as mass (Burns & Hajdukiewicz, 2004).
- The *Generalized Function* (GF) level explains the processes involved in the laws and principles found at the AF level, i.e. how each abstract function is achieved. Causal relationships exist between the elements found at the GF level.

- The *Physical Function* (PFn) level reveals the physical components or equipment associated with the processes identified at the GF level. The capabilities and limitations of the components such as maximum capacity are also usually noted in the AH (Burns & Hajdukiewicz, 2004).
- The *Physical Form* (PFo) level describes the condition, location, and physical appearance of the components shown at the PFn level. Physical characteristics may include things as colour, dimensions, and shape.

2.2.2 Skills, Rules, and Knowledge Framework

The Skills, Rules, Knowledge (SRK) framework or SRK taxonomy defines three types of behaviour or psychological processes present in operator information processing (Vicente, 1999a). The SRK framework was developed by Rasmussen (1983) to help designers combine information requirements for a system and aspects of human cognition. In EID, the SRK framework is used to determine how information should be displayed to take advantage of human perception and psychomotor abilities (Vicente, 1999b). By supporting skill- and rule-based behaviours in familiar tasks, more cognitive resources may be devoted to knowledge-based behaviours, which are important for managing unanticipated events. The three categories essentially describe the possible ways in which information, for example, from a human-machine interface is extracted and understood:

- *Skill-based behaviour* represents a type of behaviour involving routine activities that require very little or no conscious control to perform, i.e. automated (Rasmussen, 1990). It is recommended that in order to support interaction via time-space signals, the operator should be able to act directly on the information displays and that the information should reflect the part-whole structure of the system (Vicente & Rasmussen, 1990, 1992).
- *Rule-based behaviour* is characterized by the use of rules and procedures to carry out a course of action in a familiar situation (Rasmussen, 1990). Operators are not required to know the underlying principles and fundamentals of a system to perform a

rule-based activity. To promote rule-based behaviour, designers should provide a consistent one-to-one mapping between the work domain constraints and cues in the information display (Vicente & Rasmussen, 1990, 1992).

- *Knowledge-based behaviour* involves higher cognitive activities, in particular relating to problem solving and planning. This type of behaviour is required for novel and unexpected situations. Representing the work domain in the form of an AH, i.e. embedding the abstraction levels in the information display, should provide an externalized mental model to support knowledge-based problem solving (Vicente & Rasmussen, 1990, 1992).

2.2.3 Applications

The EID framework has been applied to a variety of work domains since its introduction in the field of human factors engineering. More recently, researchers have explored the use of EID information displays in the areas of aviation (Dinadis & Vicente, 1999; Ho & Burns, 2003; Nadimian & Burns, 2004), network management (Kuo & Burns, 2000; Duez & Vicente, 2005), and patient monitoring (Hajdukiewicz, Doyle, Milgram, Vicente, & Burns, 1998; Watson, Russell, & Sanderson, 2000). However, a large portion of EID research over the years has been conducted in the domain of process control; many fundamental ideas of EID were tested using a small process control simulator called DURESS (DUal REservoir System Simulation). Process control systems range from nuclear and coal power plants to milk pasteurizers. The DURESS microworld simulated a thermal-hydraulic control process typically found in a power plant. It was originally used to evaluate how well EID information displays supported unfamiliar and unanticipated situations (Vicente, 1991). The experiment compared a non-EID physical (P) display of the microworld to an EID physical/function (P+F) display that contained information from all levels of abstraction. In general, the diagnostic performance of the participants for a number of tasks and events was found to be superior in the P+F condition. The improvement was attributed in part to the added levels of abstraction in the P+F display and not to the differences in the visual forms. These results provided a good basis for further developing the EID framework and exploring other possible applications.

The DURESS simulated environment has since been adapted to study both control and monitoring behaviour (Pawlak & Vicente, 1996), EID in collaborative work environments (Garabet & Burns, 2004), and the effects of sensor noise on EID information displays (St-Cyr, 2006). Because of the generic and limited work environment depicted in DURESS, researchers have sought to analyse more representative process control systems to determine whether the benefits of EID would also apply in the other settings. Dinadis and Vicente (1996) applied the EID framework to a larger-scale feedwater system that is more representative of the complexity found in a nuclear power plant. The study incorporated many traditional interface design principles such as visual momentum and perceptual organisation, which were found to be highly complementary to the EID approach. The resulting EID information displays were successfully implemented in an ABB Limited plant simulator, i.e. showing proof-of-concept, but not evaluated with human subjects.

A notable industrial example is the application of the EID framework by researchers at the Toshiba Corporation (Itoh, Sakuma, & Monta, 1995) to a next-generation boiling water reactor nuclear power plant. However, the EID framework was used in combination with Multilevel Flow Models (MFM) describing the goals and functions of specific plant processes, which are similar to elements found at the Functional Purpose and Generalized Function levels in the AH. Separate EID information displays were designed for the plant start up and decay heat removal processes presented in the MFMs. Although an analytical study was done on the AH model showing favourable results, no empirical testing was conducted on the actual displays.

Jamieson (2002) notes that there is currently a lack of literature that focuses on empirical evaluations of the EID framework, which involve professional operators in more realistic plant settings. In his study, EID information displays for a petrochemical refining process were evaluated with 30 skilled operators in a full-scope industrial simulator. The experiment compared three types of interfaces: current mimic, EID (P+F), and EID augmented with task-based information (P+F+T). The results confirmed that the EID information displays improved performance in terms of trial completion times and number of control actions required. Furthermore, diagnostic accuracy was found to be greater for the P+F+T interface; a noticeable increase in performance was noted for

abnormal and unanticipated scenarios. These findings substantiate previous research in laboratory simulations with novice operators.

A primary goal of the HRP project described in this thesis is to evaluate advanced interfaces including EID information displays based on an existing boiling water nuclear power plant (Forsmark 3 in Sweden) with professional licensed operators. The HAMMLAB simulator environment attempts to replicate a traditional control room with upgraded technologies such as LCD monitors and projection screens. It is hoped that the combined results of the study will encourage industry to adopt innovative approaches, in particular the EID framework, in the development of next-generation operator support systems. Note that the above examples are but a few of the many studies in the process control work domain. Refer to Vicente (2002), Burns and Hajdukiewicz (2004) for a more thorough review of prior applications of EID.

2.3 Situation Awareness

Situation Awareness (SA) in the context of dynamic decision making is defined as “the perception of elements in the environment within a volume of time and space, the comprehension of their meaning, and the projection of their status in the near future” (Endsley, 1988). In brief, SA can be described as a person’s state of knowledge or a mental model of the work environment for a specific set of goals and decision tasks. Endsley (1995) emphasizes that SA should not be confounded with processes and constructs involved to achieving, acquiring, and maintaining that state; i.e. attention, perception, working memory, long-term memory, decision making, execution of actions. Although there have been a variety of attempts at defining SA, Endsley’s description of the concept has been the most widely received and applied in studying dynamic decision making. According to Endsley’s model, SA is a function of (1) an individual’s information-processing abilities, (2) the system design, and (3) other features in the work environment including workload and stress. It is therefore possible to support SA through training and experience. However, given the increasing amount of information that is being made available to operators in dynamic systems, it is imperative that HMIs are designed to facilitate the acquisition of relevant information for building SA.

SA is defined as the result of three hierarchical phases or levels that describe the key processes involved in achieving a state of knowledge of the work environment:

- *Level 1: Perception of Elements in the Environment.* The perception of relevant cues in the environment is an important first phase in the development of SA. Operators in process control plants require specific data on mass and energy flows, dynamic processes, and equipment status in order to make decisions effectively. In the aviation domain, it has been shown that 76% of SA errors occur at the first level (Jones & Endsley, 1996). In the majority of the cases, all relevant information was present in the environment, but was not detected.
- *Level 2: Comprehension of the Current Situation.* The second phase involves the integration of the perceived Level 1 elements that are relevant to decision goals via subjective interpretation and objective significance (Flach, 1995). In achieving Level 2 SA, operators acquire a holistic picture of the environment that includes the significance of the objects and events within it. Novices typically do not have the knowledge and experience to draw upon for developing Level 2 SA. In the same aviation study by Jones and Endsley (1996), approximately 19% of SA errors occur at the second level.
- *Level 3: Projection of Future Status.* The ability to predict future actions of elements and events represents the highest level of SA, i.e. highest level of understanding. In order for an operator to achieve Level 3 SA, a highly developed mental model of the current situation (Level 2 SA) is required, which depends on elements perceived in the environment (Level 1 SA). Experts typically spend a large quantity of resources developing Level 3 SA as projections allow for proactive decision making. Jones and Endsley (1996) found that only 6% of SA errors in aviation occurred at the third level; this was attributed to the difficulty in attaining Level 1 and Level 2 SA.

The concept of SA first appeared in the aviation industry, measuring pilot and aircraft controller understanding of particular situations (Endsley, 1995). However, applications have since extended beyond aviation and now include large system operations, military tactical and strategic systems, and medical or surgical operations (Endsley, 2000). In a

process control environment, the three phases of SA generally involve the detection of process disturbances, interpretation of the event, and planning to remediate the situation (Roth, Randall, & Stubler, 1993).

As mentioned previously, the development and maintenance of SA is largely influenced by the cognitive mechanisms in information processing and the design of interfaces, which are often used to represent the work environment. In a complex system, attention restricts the operator's ability to perceive multiple cues and elements in parallel (Level 1 SA). It is possible to overcome some of the limitations in directing attention by increasing the perceptual salience of cues based on priority and utilising information sampling strategies obtained through training and experience (Endsley, Bolté, & Jones, 2003). Another important bottleneck in achieving and maintaining SA is working memory. Working memory is responsible for interpreting perceived cues (Level 2 SA) and making projections (Level 3 SA). Limitations in working memory are spatial and temporal in nature, i.e. only a limited number of elements can be stored in working memory for a short period of time before decaying. Novices and operators dealing with novel situations require more working memory resources (Endsley & Garland, 2000). Experienced operators have developed mechanisms through training and experience to manage limited working memory resources such as chunking (Wickens & Hollands, 2000). However, it is hypothesized that long-term memory structures including mental models and schema are often used to support working memory. In essence, the structures model the default behaviour of the system allowing for a smaller subset of elements that are of interest to be stored in working memory, i.e. rather than all elements in the system to prevent overload. The mental models and schema can provide much of the higher levels of SA; the structures are typically only present in experienced operators. SA can therefore be thought of as a unique product of the perception of relevant environment cues, working memory processes, and long-term memory structures.

In emphasising the constraints of a work environment, EID seeks to support the cognitive mechanisms described above. The application of the SRK framework to the design of graphical elements in the interfaces aims to make much of the fault detection process skill-based. Advanced visualisation techniques such as emergent features and salience control allow for many variables in the environment to be monitored in parallel.

As a result, attention is directed to the most relevant cues that indicate potential constraint violations thus supporting Level 1 SA. By reducing the amount of attentional resources required for perception, more can be dedicated to the development of Level 2 and 3 SA. In addition to promoting skill-based behaviour, EID supports knowledge-based behaviour via visualisation of the mental model described previously as the Abstraction Hierarchy (AH). In providing a physical and functional representation of the system to the operators, knowledge existing in experienced operator long-term memory is available to novices. The higher levels of SA can be achieved using fewer working memory resources due to the support provided by shifting the long-term memory structures to the interface. The experiment described in this thesis will provide empirical evidence as to whether EID supports SA.

SA is believed to be necessary, but not sufficient for good performance in dynamic decision making (Endsley, Bolté, & Jones, 2003). Performance outcomes are affected by a variety of other factors such as workload demands, execution accuracy, and system capabilities. For example, an operator with perfect SA may perform poorly due to lack of training in carrying out the proper actions. Likewise, it is possible for an operator to have poor SA and perform reasonably well by attempting to account for missing information or simply by sheer luck. Because of this distinction, SA cannot be measured using traditional performance indicators such as response time. A number of SA measurement techniques have been developed within the last decade, a few of which are explained in the following subsection.

2.3.1 Measurement

SA is a direct measure of an operator's understanding of the system, in particular relating to the current and future states of the system. As explained previously, the level of SA possessed by an operator increases the probability of making good decisions and performing well in activities like problem solving. In order to evaluate design concepts and ideas, it is generally necessary to make relative comparisons since it is difficult to determine a benchmark representing good SA for a particular application. In this thesis, operator SA for EID information displays is compared to that of more traditional mimic-

oriented displays. Although SA can be measured indirectly by assessing the cognitive processes involved, it is not always possible to infer one from the other. Accordingly, direct measures of SA are of particular interest in the evaluation phase. There exist both subjective and objective direct measures of SA. In general, subjective measures assess SA via self- or expert-ratings during a specified period, which can be as simple as using a Likert (number) scale. However, ratings can be influenced by factors such as performance and awareness of one's own SA; zero correlation has been found between subjective measures and objective measures (Endsley, Bolté, & Jones, 2003). Objective measures typically assess SA via queries in regards to aspects in the environment and examining the accuracy of the responses. Several challenges in administering objective measures include establishing appropriate queries and intervals as they have the potential for interfering with performance, workload, memory, and attention. Below is a brief overview of three SA measurement techniques, two of which are used in the evaluation of EID information displays described in this thesis.

2.3.1.1 Halden Open Probe Elicitation (HOPE)

The Halden Open Probe Elicitation (HOPE) measure is a real-time subjective measure of operator SA developed for the study in question by the Halden Reactor Project. The methodology is similar to the Situational Awareness Rating Scale (SARS) developed by Waag and Houck (1994) in which observers rate pilot SA based on observed behaviours. HOPE addresses operator Level of Understanding (LoU) as it relates to a variety of cognitive processes in a work situation. Real-time open probes via verbal queries are used to determine operator LoU. For example, operators may be asked if everything is normal, what strategies they are following with respect to the current state of the system, or whether a specific problem has been resolved. Such open probes are natural in a control room environment since operators generally provide status updates to other plant personnel. It is important that the probes are open-ended to the extent that it prevents cueing, i.e. guiding the operator in problem solving. Rather than measuring response time of the probes, an expert observer rates the operator's LoU on a scale of 0 (poor understanding) to 3 (full understanding). An aggregated LoU is calculated from the

scores of several probes during each scenario in the experiment. Please refer to Appendix G for a full description of the LoU scale.

The content, format, and timing of the verbal queries are pre-defined for each scenario based on the expected events and performance requirements. It may be necessary for the expert evaluator to modify the queries since operator activities can influence scenario development. Before the experiment, operators are informed that a member of the experimental team will act as a representative from plant management who may call the control room for status updates, i.e. probes. Because status calls are typically considered secondary tasks, operators are likely to dismiss it during high workload periods. In order to prevent this, the simulator running the scenario is frozen while the operator responds to a probe; however, the information displays remain available and are not blanked. Each probe is under a minute in length to minimize potential interference with scenario progression. The operators will respond to probes verbally based on their current understanding of the situation. The expert evaluator can also infer LoU from observations such as operator interventions with the process, search for information, HMI navigation, and reaction to alarms. It is expected that LoU can be reliably measured and predict operator performance.

2.3.1.2 Situation Awareness Global Assessment Technique (SAGAT)

The Situation Awareness Global Assessment Technique (SAGAT) is perhaps the most widely used SA measure in domains such as aviation, air traffic control, process control, teleoperations, and military operations. Unlike subjective measures, SAGAT aims to evaluate operator response to queries about specific elements in the work environment. The accuracy of the responses can be used to objectively determine an operator's SA for a particular scenario. The queries are established ahead of time based on a detailed analysis of SA requirements, which is essentially a goal-directed task analysis that attempts to determine all information required for a particular decision (Endsley, Bolté, & Jones, 2003). The information identified in the analysis is similar to the variables extracted in the EID design approach, though specific to a particular task or scenario and categorized by SA level. Each query represents a variable identified in the SA

requirements analysis and measures one or multiple levels of SA. A list of queries is administered to the operator at randomly selected intervals within the scenario. The simulator is frozen and the displays are blanked while the operator responds to the queries. For example, operators may be asked to indicate the water level in a tank, whether it was rising or falling, and what (if any) alarm it was approaching.

When the operator completes the list of queries, which takes around 2 to 3 minutes, the scenario is resumed. There have been concerns as to whether the scenario freezes interfere with operator memory and performance (Pew, 1995). Validation studies of SAGAT (Endsley, 1995, 2000) have shown that participants are able to resume scenario tasks with minimal effects to performance. However, SAGAT is only reliable to the extent that it adheres to certain requirements: randomized freezes to prevent cueing, appropriate time interval between freezes, and queries that cover information required for all three levels of SA (Endsley, Bolté, & Jones, 2003). One of the major advantages of measuring SA with SAGAT is that the results provide designers with an idea where improvements in the information displays can be made. In particular, it highlights levels at which specific information or variables are lacking in terms of design. Limitations of SAGAT pertain mainly to feasibility of scenario freezes in real-world or field-testing settings such as military exercises where mid-scenario interruptions are not possible. This is typically not a problem in process control simulation environments that can be paused and resumed, e.g. HAMMLAB.

2.3.1.3 SACRI

Situation Awareness Control Room Inventory (SACRI) is an objective measure of operator SA developed by the Halden Reactor Project for process control plant environments. The SACRI measure combines elements from SAGAT and Signal Detection Theory (Wickens & Hollands, 2000). Signal Detection Theory is applicable in situations where there are two discrete states in the environment: signal and noise. During the perception process, an operator can decide whether a specific signal or variable condition is present or not. The result of the decision falls under one of four categories: (1) hit, (2) miss, (3) false alarm, or (4) correct rejection. Perfect performance is achieved

when there are no misses or false alarms. In process control, operators are concerned with detecting drifts in the plant process. Depending on the classification, a measure of operator sensitivity to changes and response bias can be calculated (Hogg, Follesø, Strand-Volden, & Torralba, 1995). The sensitivity measure is thought to measure accuracy of SA assessment, while response bias provides a qualitative indication of what strategies are employed for certain process fluctuations, i.e. conservative or risky strategies. When comparing different process control information displays, SDT can be used to develop an overall view of operator SA as well as performance. For example, two information displays may produce similar SA accuracy, but one results in better projection from proper strategy selection.

A SACRI score is derived by applying elements of SAGAT in the evaluation and elements of SDT in the analysis of the collected data. During the experiment, operators answer a battery of questions about the state of the process at random freezes in the scenarios. The queries used involve responses that classify variables roughly as increasing, decreasing, or no change. The responses are evaluated against data found in simulator logs and categorized into one of the four SDT decision conditions; operator sensitivity and response bias values are calculated from the number of responses found in each category. Please refer to Appendix H for complete operator sensitivity and response bias formulae. An operator sensitivity score of 1.0 is equivalent to perfect performance, while any score below 0.5 indicates performance no better than if the decision was made by chance. A response bias of 1 represents zero bias, i.e. no overestimation, no underestimation of particular variable values. A response bias over 1 indicates overestimation or risky bias, while a response bias under 1 indicates underestimation or conservative bias (Hogg, Follesø, Strand-Volden, & Torralba, 1995). The SACRI scores are used in place of accuracy scores that are typically calculated in the SAGAT measurement and analysis technique.

Chapter 3

Ecological Interface Design for Turbine Secondary Systems

The Ecological Interface Design (EID) framework consists of two key stages: the Work Domain Analysis (WDA) and the Skills, Rules, and Knowledge (SRK) framework. The WDA provides designers with information relating to the physical and functional aspects of the system. Specifically, the analysis reveals work domain constraints and complex system relationships; this information is subsequently transformed into visual (or auditory) forms that take advantage of human perceptual and problem solving abilities as described by the SRK framework. Many advanced visualisation techniques have been established to achieve the jump from analysis to design (Burns & Hajdukiewicz, 2004). The following sections describe the EID design process and results for the turbine secondary systems of the Swedish Forsmark 3 boiling water reactor (BWR) nuclear power plant.

3.1 System Description and Boundary

A typical modern nuclear power plant consists of a primary reactor system and a number of secondary systems designed to convert thermal (steam) energy into electrical energy. Despite significant differences in the steam-heating process, electricity generation via the secondary systems in both nuclear and fossil fuel power plants rely on the same principle: rotation within the generator. The process essentially involves turning turbine blades with high-pressure steam, which directly results in generator rotation. In order for the process to continue, the secondary systems are also responsible for condensing post-turbine steam and returning it to the reactor.

In a boiling water reactor plant (BWR) such as Forsmark 3, water is boiled directly in the reactor core, rather than through a separate loop and boiler as found in pressurized water reactor (PWR) and CANDU nuclear power plants. The secondary systems in a BWR therefore must take into account traces of radioactivity in the water and differences in pressure. Although the principles behind electricity generation is identical in all nuclear power plants, the actual process can differ greatly from plant to plant; such details are reflected in the physical and functional attributes of the system, which are revealed in the Work Domain Analysis (WDA).

Unlike user-centred design approaches, the EID framework begins with an analysis of the work environment, i.e. the nuclear power plant. Physical boundaries were established between the secondary systems in the Swedish Forsmark 3 BWR nuclear power plant to allow for concurrent analyses: turbine, condenser, and feedwater secondary systems. Recall that the scope of the project is limited to the secondary, non-reactor, side of the plant. Additionally, this thesis focuses primarily on the turbine secondary systems as delineated in Figure 3. A number of physical components can be seen within the turbine system boundary including a high-pressure turbine, three low-pressure turbines, a moisture separator reheater, a generator, and various control valves. Operators are largely concerned with monitoring and controlling the plant process. Accordingly, the scope of the system was narrowed to exclude control systems (e.g. governor), actuators (e.g. electro-hydraulic valve actuators), and sensors (e.g. temperature). Troubleshooting of the excluded components is typically carried out by maintenance and field personnel.

While the operation of a nuclear power plant is collaborative in nature, the topic of EID and collaboration is beyond the scope of this thesis. See Garabet and Burns (2004) for a discussion on the subject. As a result, the social aspects of the work environment were also excluded from the system boundary. The initial study focuses on EID information displays for a single user, i.e. the turbine operator, in a multi-user environment. By clearly defining the physical boundaries between the turbine, condenser, and feedwater secondary systems, the interactions between them become apparent during the analysis. Furthermore, it allows for relevant physical and functional attributes of the

system to be modelled via two WDA processes: (1) part-whole decomposition and (2) abstraction hierarchy, respectively.

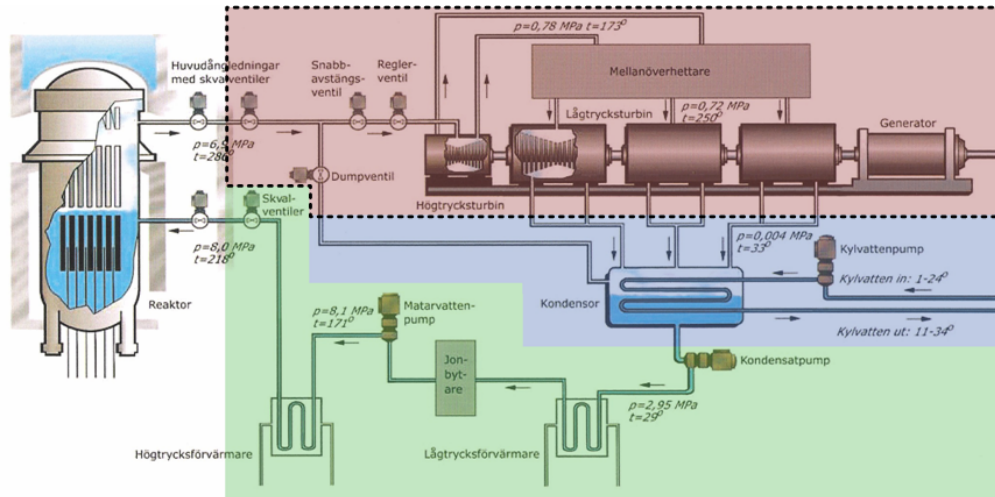

Figure 3: Turbine, Condenser, and Feedwater System Boundaries

3.2 Work Domain Analysis

3.2.1 Part-Whole Decomposition

A part-whole decomposition analysis yields a hierarchical model of the system at three different levels of detail: (1) system, (2) subsystem, and (3) component (Burns & Hajdukiewicz, 2004). Given that the turbine secondary systems consist of over a hundred process-related components, it was necessary to begin the analysis at the highest (system) level of detail. The part-whole model at the system level provides a general overview of the system typically by illustrating the inputs and outputs, i.e. representing the system by a black box. Given the many interactions between the three secondary systems, some outputs from the turbine system appear as inputs to the condenser and feedwater systems. The part-whole model at the second level details subsystem interactions within the system black box, i.e. representing subsystems with black boxes. Likewise, the part-whole model at the third level opens the subsystem black boxes to reveal interactions between actual physical components such as control valves and turbines.

The part-whole models allow designers to determine how information can be grouped in the graphical displays. For example, high-level information found at the

system level of detail (e.g. electrical power output) is generally shown on overview or status displays, whereas lower-level information found at the component level of detail (e.g. valve position) is shown on detailed displays. The models also provide designers with a better understanding of the system and its physical processes. A range of resources were used at this stage of the analysis including plant specifications, piping and instrumentation diagrams (P&ID), existing mimic displays (see Appendix A), and process experts.

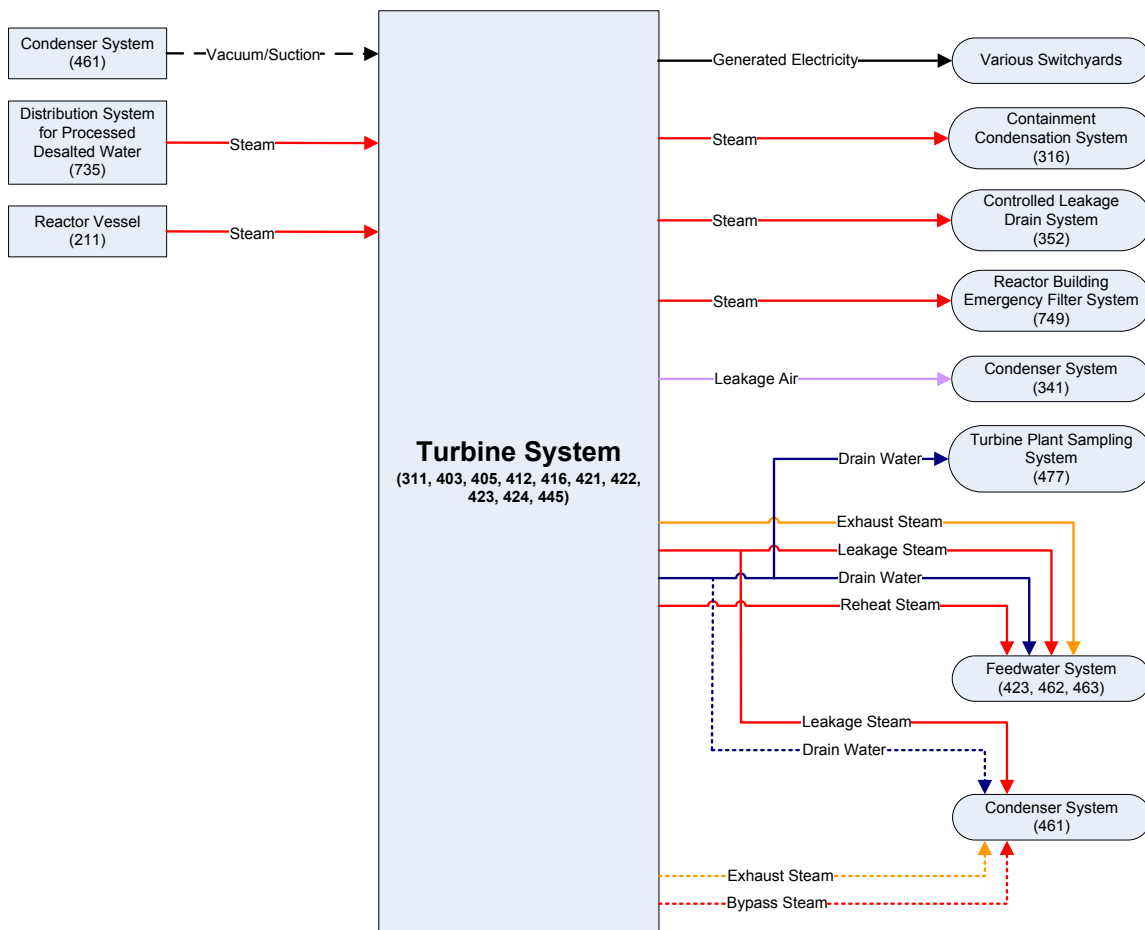

Figure 4: Part-Whole Model of the Turbine System at the System (Black Box) Level

At the highest level, the turbine system is represented by a black box (see Figure 4); the flow of process materials across the physical boundary is emphasized. Each box represents a physical component or an encapsulation of physical components in the system identified by a set of numbers (see Table 18 in Appendix B for a complete

legend). Each arrow represents a process material (colour, see Figure 43 in Appendix B for a complete legend) and its expected flow direction. Inputs are shown as unfilled rectangles. Outputs are shown as rounded unfilled rectangles. The primary reactor systems transfer steam into the turbine secondary systems for electrical power generation. Electrical energy is transferred out of the turbine system black box to various switchyards for consumer distribution. Exhaust steam and drain materials from the processes are distributed to a variety of secondary systems including the condenser and feedwater systems. For example, bleed steam from the turbine system is transferred to the feedwater system for reheating purposes. Note that vacuum/suction from the condenser system is not technically a process material as there is no flow, but a pressure component required for other process materials to enter the condenser system from the turbine system.

Once the turbine system inputs and outputs were identified, the black box was opened up to reveal numerous supporting subsystems: steam reheat systems, seal and leakage system, lubrication and jacking oil system, seal oil system, and generator cooling system (see **Error! Reference source not found.**). The flow of process materials is again emphasized at the subsystem detail level. For example, exhaust steam from the high-pressure turbine enters the steam reheat system before reaching the low-pressure turbines as superheated steam. At the subsystem level of detail, process materials flowing into the turbine system (inputs) arrive at specific subsystem destinations. Similarly, process materials flowing out of the turbine system (outputs) exit specific subsystems. Information found in the model at this level provides designers and eventually users, generally via system-specific (vs. system-wide) status displays, with a more detailed overview of the system.

The lowest level of detail was modelled by breaking down the subsystems into individual physical components; the resulting model is quite similar to a P&ID diagram. For purposes of simplicity, a part-whole model was developed for each subsystem (see Figures 6, 7, 8, 9 for steam related subsystems; see Figures 44, 45, 46 in Appendix C for remainder). Included in each model are list of indicators. The main steam subsystem (421) consists primarily of four turbine control valves, one bypass control valve, and a high-pressure turbine. The control valves regulate steam flow and pressure

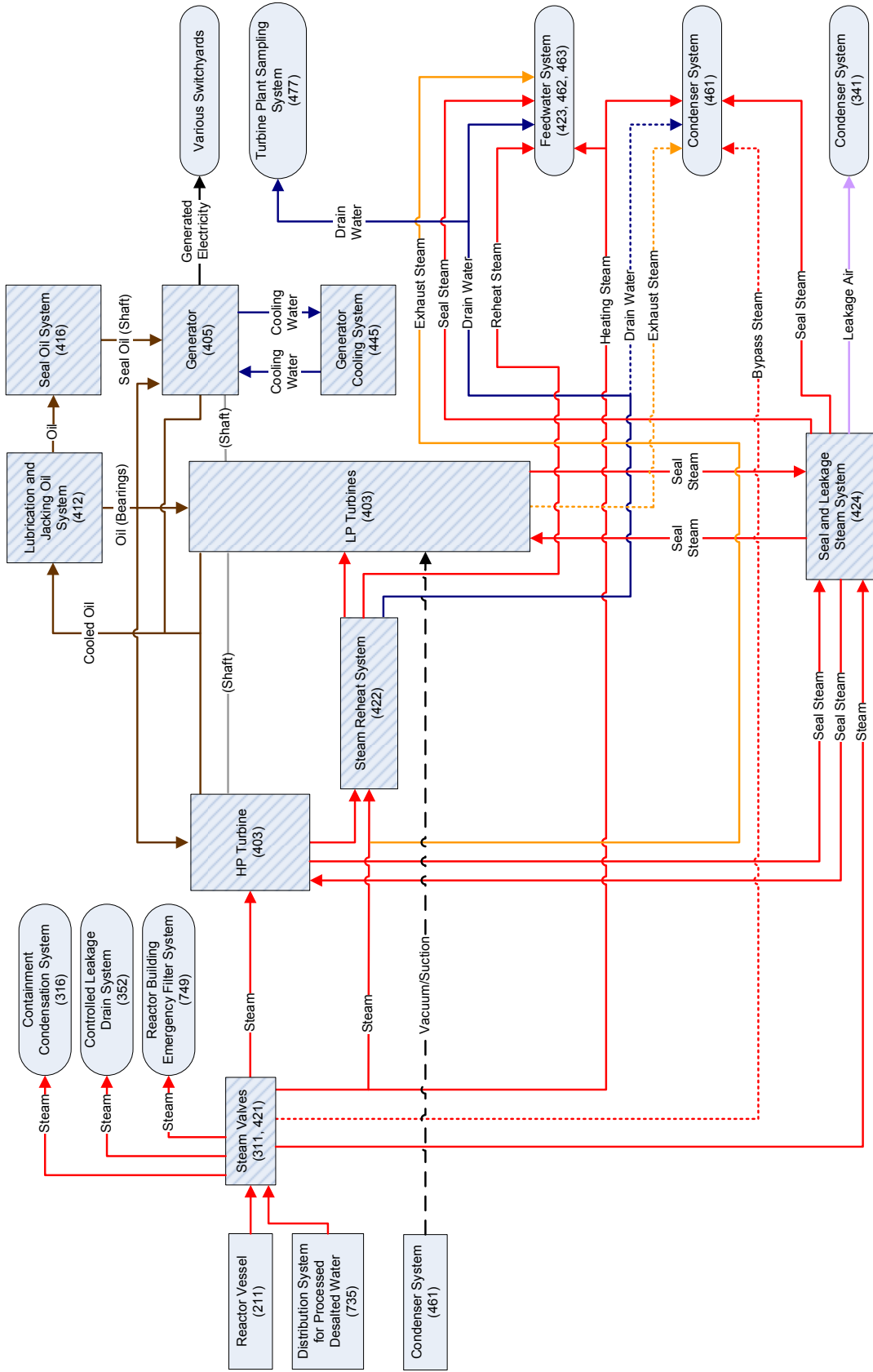

Figure 5: Part-Whole Model of the Turbine System at the Subsystem Level

- List of Indicators**
- Valves:**
 TRI – KA501
 TRI – KB501
 TRA – KA503
 TRA – KB503
 TRA – KA504
 TRA – KB504
 TRA – KA505
 TRA – KB505
 TRA – KA506
 TRA – KB506
- Pipes:**
 PI – KA101
 PI – KB101
 PI – KA102
 PI – KB102
 TRI – KA501
 TRA – KA508
 TRA – KB508
- Tank:**
 TRA – KB507
 PI – KB113
 PI – KB116
 LA – KB401 (H1)

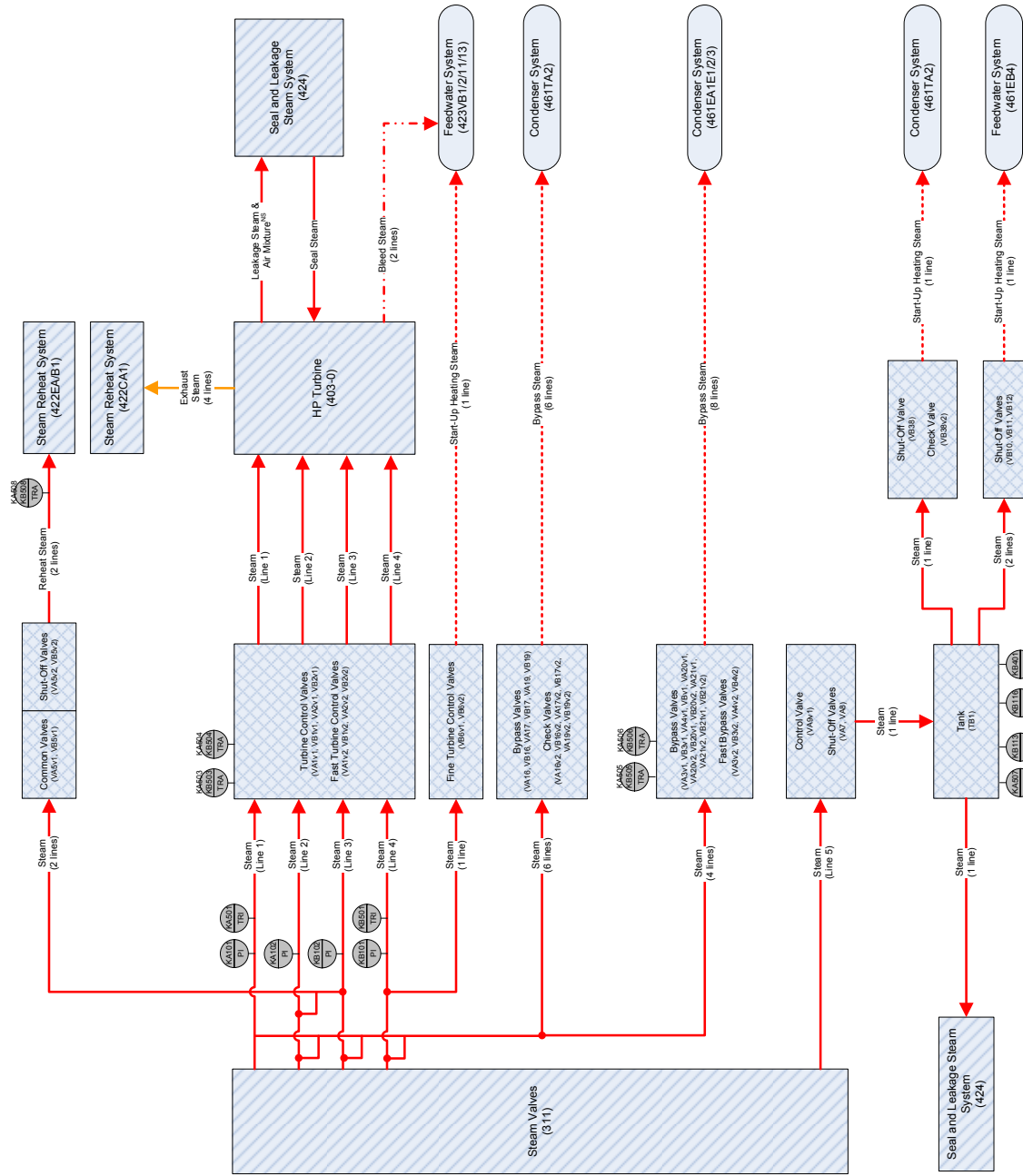

Figure 6: Part-Whole Model of the Main Steam (421) Subsystem

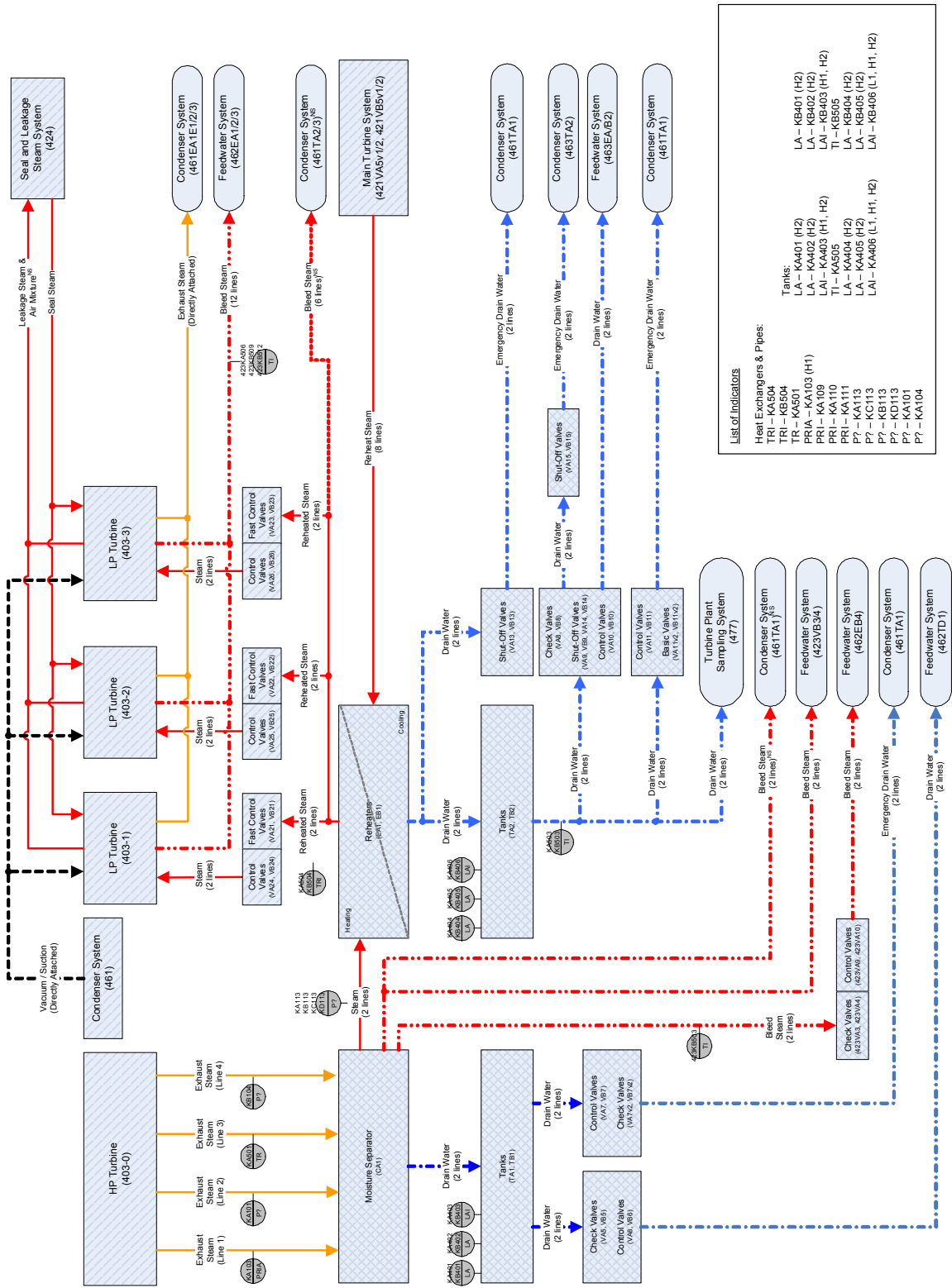
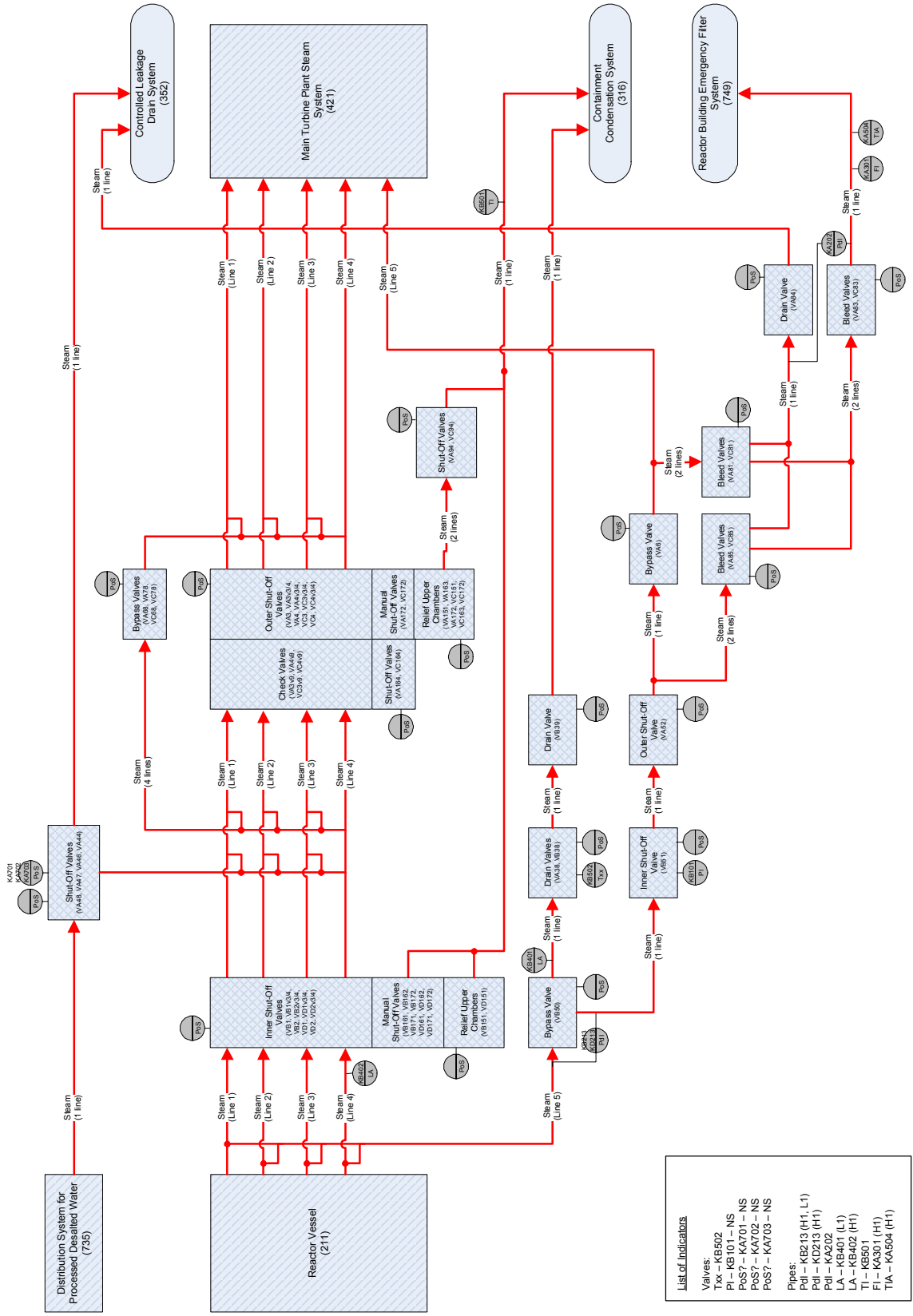

Figure 7: Part-Whole Model of the Steam Reheat (422) Subsystem



- List of Indicators**
- Valves:
 - Tx - KB502
 - PI - KB101 - NS
 - POS7 - KA701 - NS
 - POS7 - KA702 - NS
 - POS7 - KA703 - NS
 - Pipes:
 - Pd1 - KB213 (H1, L1)
 - Pd1 - KD213 (H1)
 - Pd1 - KA202
 - LA - KB401 (L1)
 - LA - KB402 (H1)
 - FI - KB501
 - TI - KA301 (H1)
 - TIA - KA504 (H1)

Figure 8: Part-Whole Model of the Steam Valves (311) Subsystem

entering the high-pressure turbine. Exhaust steam from the high-pressure turbine is redirected to the steam reheat subsystem (422), which is comprised of a moisture separator, shell and tube heat exchangers, tanks, and numerous valves (e.g. control, stop, check valves). Superheated steam leaving the shell and tube heat exchangers enter three low-pressure turbines for further energy conversion. The main steam (421) and steam reheat (422) subsystems are supported by the seal and leakage steam (424), lubrication and jacking oil (412), seal oil (416), governing oil (452), generator cooling (445), and bus bar cooling (614) subsystems. The steam valves subsystem (311) pre-regulates steam flow to the main steam subsystem. The functional attributes including purposes and process descriptions of each part-whole model are further detailed in the abstraction hierarchy analysis discussed in the following section.

The advantage of clearly identifying the inputs and outputs of the system is that individual models from each of the secondary systems (turbine, condenser, feedwater) can be readily integrated. For the purposes of deriving a large-screen overview information display of the secondary systems, the part-whole models were merged. The discussion of overview displays is beyond the scope of this thesis, but the resulting integrated models of the part-whole system (Figure 47 in Appendix C) and subsystem (Figure 48 in Appendix C) levels are available for reference.

3.2.2 Abstraction Hierarchy

While a part-whole model provides details concerning the physical attributes of the work environment, an abstraction hierarchy (AH) model focuses on the functional attributes (Burns & Hajdukiewicz, 2004). The AH analysis examines the means and ends (i.e. how and why, respectively) of the system by modelling it at five distinct levels of abstraction: (1) Functional Purpose, (2) Abstract Function, (3) Generalized Function, (4) Physical Function, and (5) Physical Form (Vicente, 1999b). Elements at lower levels of abstraction provide the means to which elements at higher levels are achieved. The model is used at the design phase to determine the kinds of information to display along with the associated constraints and relationships. Furthermore, the information is organized based on the different levels of abstraction to promote knowledge-based behaviour as described

in the skills, rules, and knowledge (SRK) framework. The AH is one of the key defining characteristics of the EID framework in contrast to other design approaches.

A variety of different resources were used in the development of each abstraction level in the AH. At the Functional Purpose level, the goals of the system were determined by consulting operator training manuals (Ontario Power Generation, 1988) and prior EID research (Dinadis & Vicente, 1996). The laws and principles describing the goals of the system at the Abstract Function level were investigated using textbooks, in particular relating to thermodynamics (Çengel, 1997) and electromagnetism (Halliday, Resnick, & Walker, 1996). Similarly, textbooks and operator training manuals relating to the operation of turbines (Lindsley, 2000; Ontario Power Generation, 1994) and generators (Canadian Nuclear Safety Commission, 2003) in nuclear power plants were used to investigate processes described at the Generalized Function level. Plant literature referred to in the part-whole analysis, as well as the part-whole models, were employed directly to describe the Physical Function and Physical Form levels. Process experts were consulted throughout to acquire Forsmark 3 plant-specific information.

The turbine system was examined at each part-whole level of detail yielding three separate AH models, which combined with the part-whole models formed a complete work domain model. At the part-whole system level of detail, the AH provides a black box overview (see Figure 10). In a complex system, there are generally multiple goals that constrain one another due to practical limitations and tradeoffs, e.g. the goal of generating electricity to specified levels is constrained by several safety factors such as maintaining safe reactor pressure and turbine speeds. Specific laws and principles described at the Abstract Function level regulate the above goals, which are in turn carried out by processes found at the Generalized Function level. As shown in Figure 10, the first and second laws of thermodynamics along with the Faraday-Lenz law underlie the goal of electricity generation. The processes of steam throttling and expansion at the Generalized Function level are associated with the first and second laws of thermodynamics. Likewise, the process of electromagnetic induction is associated with the Faraday-Lenz law. At the Physical Function level, equipment identified in the part-whole analysis such as turbines and generators are linked to the corresponding Generalized Function processes. The physical properties for each piece of equipment

(e.g. size, location, capacity) are recorded at the Physical Form level; for practical purposes, this level was omitted in the current phase of analysis. Plant literature and specifications were referred to as necessary to acquire Physical Form level information.

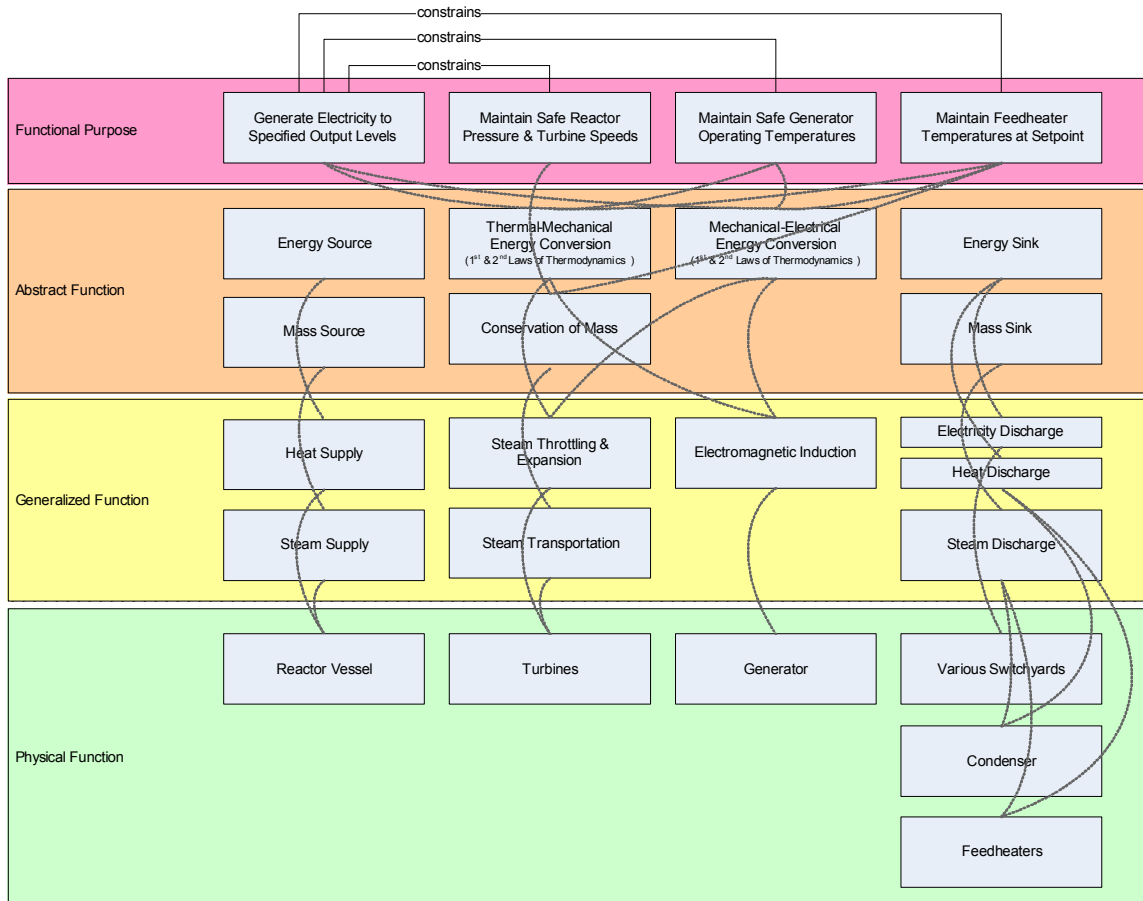

Figure 10: Abstraction Hierarchy at Part-Whole System Level

Similar models were constructed based on the part-whole subsystem and component levels. At the part-whole subsystem level of detail, the AH expands on the functional attributes of the black box system (see Figure 11). Specifically, the Abstract Function and Generalized Function levels include elements relating to the supporting subsystems identified in the part-whole analysis. For example, the steam reheat subsystem is responsible for mass separation (liquid-vapour) and transformation (saturated-superheated) abstract functions; this corresponds to moisture separation and steam reheating Generalized Functions. Causal (horizontal) links were included at the Abstract Function and Generalized Function level to emphasize process flow. At the

Physical Function level, the subsystems identified in the part-whole analysis are reiterated. Recall that elements from each level are connected to others above or below via means-end (vertical) links.

At the part-whole component level, an AH was developed for the main steam and steam reheat subsystems (421 and 422, Figure 12). Note that the subsystems were merged to provide better process flow continuity. Although many of the goals at the Functional Purpose level are similar to the ones found at the part-whole system and subsystem levels of detail, the elements at the Abstract Function and Generalized Function levels are associated directly with the individual components at the Physical Function level. For example, tanks in the steam reheat subsystem are treated as drain stores for other processes, which are associated with mass storage.

A major challenge encountered due to the modularisation of the secondary systems was consistency between each subsystem. In effect, specific outputs of the turbine secondary systems should be consistent with the inputs to the condenser or feedwater secondary systems. For example, the energy sink representing steam discharge in the turbine system should be shown as an energy source in the condenser system. The interactions between the systems were emphasized to avoid “losing” information during the design phase of the project. The AH models at the system (Figure 49 in Appendix C) part-whole level for the turbine, condenser, and feedwater secondary systems were in the end combined to aid the design of a large-screen overview information display. Again, it should be noted that the discussion of overview displays for the three secondary systems is beyond the scope of this thesis.

3.3 Information Display Design

3.3.1 Information Analysis

The information analysis stage attempts to bridge the gap between system analysis (i.e. models) and design (i.e. information displays). Unlike other design approaches, EID relies primarily on the AH models to determine what information needs to be included in the displays. The information is based solely on the known capabilities of the system

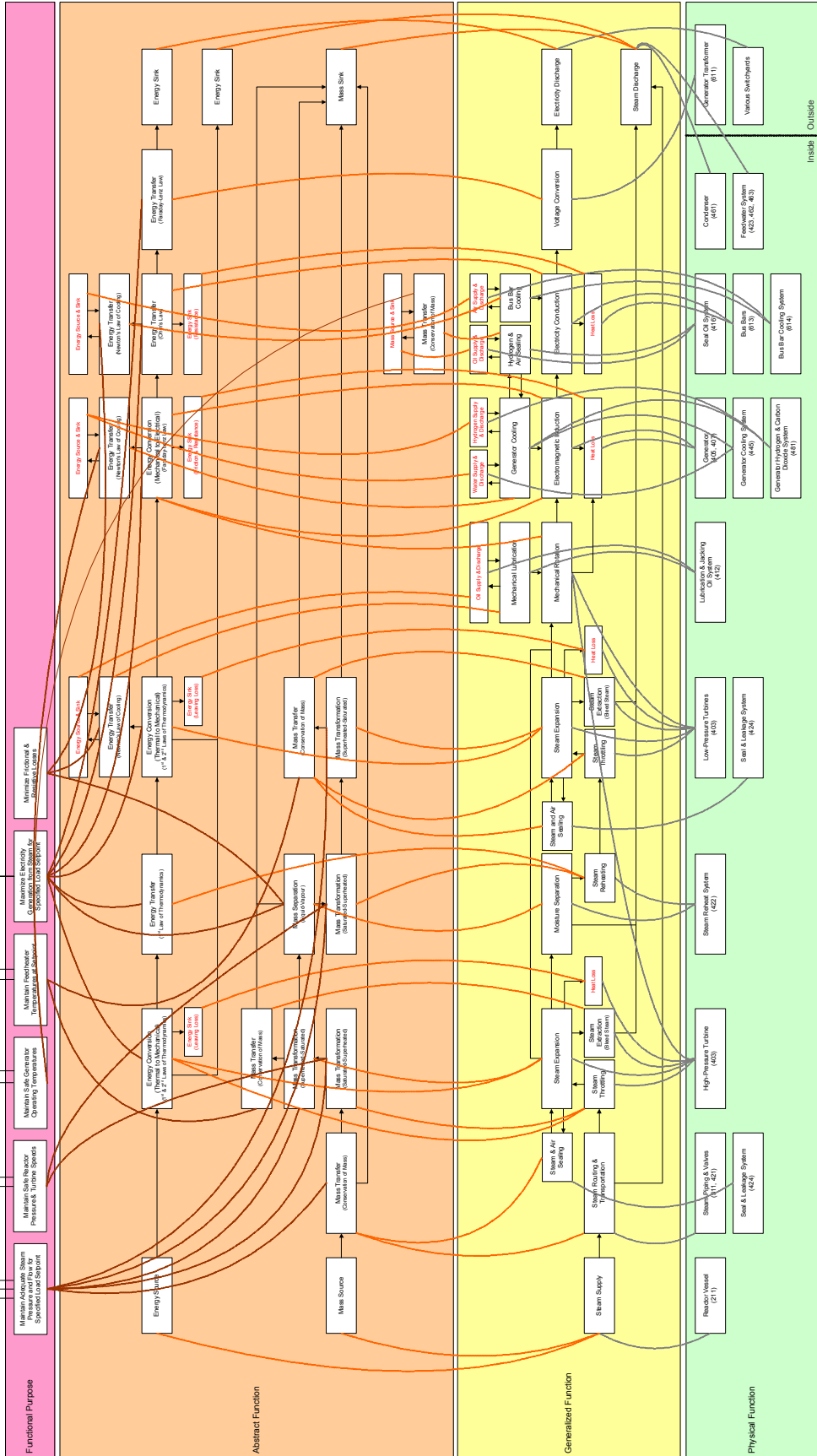

Figure 11: Abstraction Hierarchy at Part-Whole Subsystem Level

rather than on user experience or specific operating tasks. In a large complex system like a nuclear power plant, it is often not practical to gain information by asking operators what they would like to see on the human-machine interfaces (HMI). Suggestions tend to vary widely based on expertise, while some operators feel that there is no need to include more information. Furthermore, information based on task analyses does not necessarily support unanticipated events; tasks are known anticipated events. The EID framework concentrates on obtaining information that supports both anticipated and unanticipated events. However, it is possible to combine multiple design approaches to provide complementary information in the HMIs (Burns & Hajdukiewicz, 2004).

Information to be translated on to the EID information displays is obtained by extracting variables from the AH models developed in the previous phase (Burns & Hajdukiewicz, 2004). The variables are identified by asking how each element in the AH can be measured. For instance, the goal of generating electricity to a specified set point can be measured by real and reactive power output variables. Measures related to flow, balance, and conservation were extracted from elements at the Abstract Function level. Likewise, process related variables such as temperature and pressure were identified at the Generalized Function level. At the Physical Function level, equipment can be measured by examining its capacity and capability.

Table 1: Extracted Variable at the Abstract Function Level

Variable	Energy in from the reactor
Description	Specific enthalpy of steam leaving the reactor
Units	kJ/kg
Availability	Calculated: steam table lookup
Constraints	Max: ~2,772.1 kJ/kg Min: 0 kJ/kg Normal: ~2,742.1 kJ/kg
Relationships	Approximately equal to energy into high-pressure turbine

The information analysis phase also involves identifying information availability and constraints, which are key aspects in EID information displays. These attributes serve as design parameters for creating graphical elements and were recorded in tables for easy referencing (see Table 1 for an example entry, Table 19 and Table 20 in Appendix D for

all more complete entries). A variable can be measured via sensors or calculated from other variables, or is simply not available, in which case it cannot be designed into the displays. Like many existing nuclear power plants, energy cannot be measured through sensors. Instead, the value must be obtained through a steam table lookup using temperature or pressure values.

Two types of constraints exist for variables: single variable constraints and multivariate constraints. The range-limit of a particular variable (i.e. maximum and minimum values) is considered a single variable constraint. The relationships between multiple variables are considered multivariate constraints. Energy leaving the reactor is related to energy flowing into the high-pressure turbine in that the two are approximately equal (see Table 1). It is possible for one variable to be related to another through complex mathematical expressions as dictated by known physical models. Apparent power, for example, is equal to the hypotenuse of a right-angle triangle consisting of real and reactive power (see Figure 17). The relationship is known as the power triangle. The following section describes how the extracted variables and related properties were transformed into graphical forms.

3.3.2 Graphical Forms

The information analysis tables essentially provide design parameters for graphical visualisation, helping narrow the gap between analysis and design. Specifically, the constraints and relationships of the variables were incorporated into the graphical forms and organized in a manner that conformed to the skills, rules, knowledge (SRK) framework. The SRK framework describes three different types of behaviour or psychological processes present in operator information processing: skill-based, rule-based, and knowledge-based behaviour. For example, designing a graphic that shows the difference between two values rather than requiring the operator to perform the calculation mentally supports skill-based behaviour. In contrast, graphical forms representing variables can be arranged in a display based on the AH levels to support knowledge-based behaviour. Refer to Chapter 2 for a more thorough background description of the SRK framework. The displays went through several iterations based on

the need for visual consistency between the three secondary systems, feedback from the pilot study, and practical simulator limitations (i.e. implementation constraints).

To aid the design process, Burns and Hajdukiewicz (2004) have developed a “Visual Thesaurus” from which graphical forms can be modelled. Many of the generic graphical forms utilize advanced visualisation techniques such as emergent features, which were used to emphasize variable constraints and relationships. An emergent feature is essentially a global property linking a set of individual variables or attributes, which are not as evident if represented in isolation (Wickens & Hollands, 2000). The maximum and minimum limits should be apparent on a single variable with respect to the current value. Similarly, deviations in the expected relationship between multiple variables should be of high salience. Such visual features promote skill-based behaviour by reducing cognitive resources required for detecting important changes. The following subsections describe the design of graphical forms at the different levels of abstraction in the AH model.

3.3.2.1 Design at the Functional Purpose Level

Due to the complex relationships that exist between a number of variables, including time, the design phase focused largely on visualising multivariate constraints. Variables found at the Functional Purpose level related to the reactor pressure (Figures 13, 14, 15), turbine speeds (Figure 16), and generator output (Figure 17) were considered to be multiple variables. The goal of maintaining safe reactor pressure while generating electrical power to a specific set point involves all of the aforementioned variables.

Because the relationship between reactor pressure (Figure 13) and turbine control valve positions (Figures 14, 15) is too complex for calculation- or simulation-based design, the graphical forms were separated, but placed in close proximity to each other. As a result, it is possible for operators to rely on training and experience to determine whether the relationship holds via pattern recognition. The visualisation is intended to support both skill- and knowledge-based behaviour. Reactor pressure is shown over time (i.e. rate) based on changes in the turbine control valve positions and is constrained by specific maximum and minimum values. Alarms are triggered at these limits (shown as

H4 and L2 in Figure 13), but the trend over time provides operators with a visual indication of whether reactor pressure is increasing or decreasing towards these limits. It should be noted that if an alarm is triggered, the current value is highlighted based on existing severity colours (i.e. yellow, red) and operators are trained to consult written procedures. Accordingly, rule-based behaviour is not directly supported by the display.

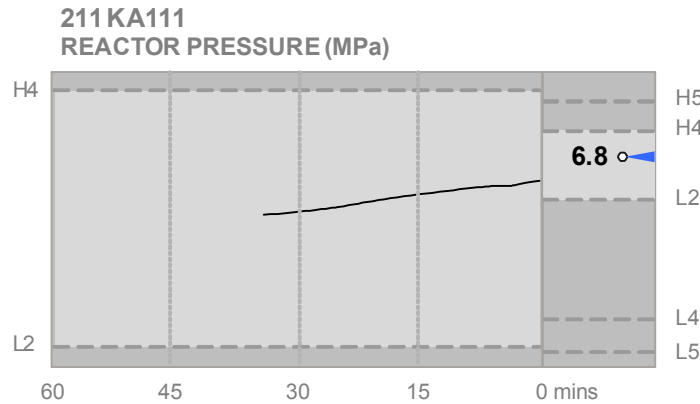

Figure 13: Reactor Pressure Graphic at the Functional Purpose Level

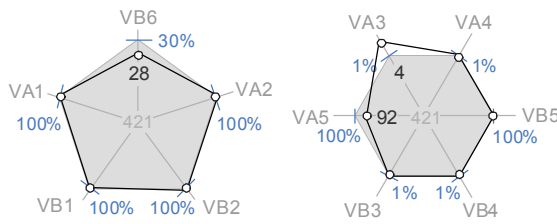

Figure 14: Valve Position Graphic (Polar Star) at the Functional Purpose Level

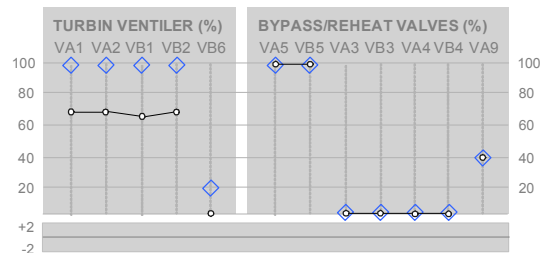

Figure 15: Valve Position Graphic (Grid) at the Functional Purpose Level

Although turbine control valve position is associated with reactor pressure, the graphical form representing the former includes many individual constraints. In particular, valve position set points established by the governor support system based on power generation requirements are shown in Figure 14 as ticks and in Figure 15 as blue diamonds. The current valve positions are specified by white dots, which will under normal conditions move towards the corresponding set points. The graphical form in Figure 14 is known as a polar star; when the current valve positions deviate from the set points, the outlined shape becomes distorted. The saliency of changes in the polar star

graphic supports skill-based behaviour and as a result enables operators to devote more cognitive resources to other tasks. Due to implementation restrictions with the current HMI design tool (Picasso), the polar star graphic was redesigned and replaced with the graphical form shown in Figure 15. Note that there are four primary high-pressure turbine control valves (VA1, VA2, VB1, VB2), which are connected via lines to indicate the variables' relationship, i.e. valve positions should be identical. The connecting lines are another example of an emergent feature. The governor support system is also responsible for sending the appropriate signals to the valves for opening and closing; the signals are represented by positive and negative bars located below the valve position grid. The signal sent to a particular valve should reflect the direction in which it is moving, e.g. a signal of -2 should close the target valve.

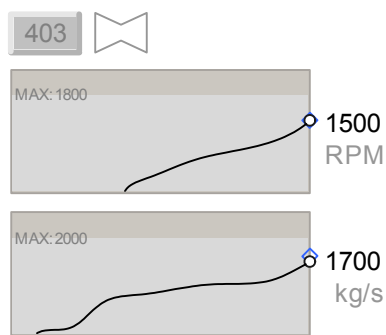

Figure 16: Turbine Speed Graphic at Functional Purpose Level

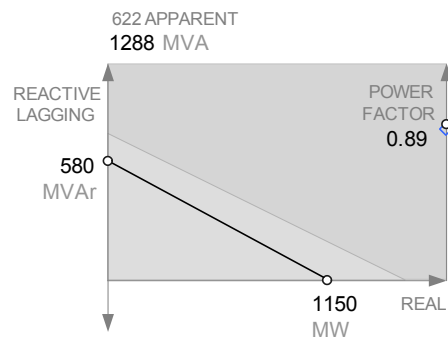

Figure 17: Generator Output Graphic at Functional Purpose Level

Turbine control valves, which regulate steam pressure and flow, directly control turbine speed (Figure 16) during generator run-up and while the system is under load or operating under normal conditions. In turn, turbine speed affects generator torque and as such increases or decreases electrical power output (Figure 17). Similar to the reactor pressure graphical form, turbine speed is displayed as a trend with maximum and minimum limits.

Since the dimensions of electrical power are related in a simple mathematical fashion, the graphical form is based on its common geometric representation known as the power triangle. Adopting familiar graphical forms effectively promotes knowledge-based behaviour. Variables visualized in Figure 17 include real power, reactive power,

apparent power, and power factor. Power generation is constrained by the capabilities of the generator and is shown in the graphical form as a shaded background triangle, i.e. the power triangle should remain within this background shape. In the event that reactive power becomes capacitive (negative), in which case reactive power is flowing into the turbine system, the power triangle flips vertically to increase saliency. Apparent or total power is a product of the voltage and current leaving the generator, but is typically calculated from real and reactive power values. Operators may need to individually adjust real and reactive power output based on consumer demands. Utility companies often base rates on both real and reactive power consumption. The efficiency of power consumption is determined by the power factor variable, which is calculated by observing the ratio between real power and apparent power.

3.3.2.2 Design at the Abstract Function Level

Variables extracted at the Abstract Function level are related to balances and flows in the system; mass and energy variables are of particular interest in the turbine system.

Although nuclear power plant operators do not traditionally refer to mass and energy flow information, the EID framework aims to present all relevant work environment constraints found in the underlying system. Doing so allows operators to monitor the system from a top-down perspective and identify out of bounds conditions even if the fault is unfamiliar and unanticipated (Vicente, 1999a). Faults in the system result from one or more violations in the constraints. In effect, the overall consequences of a low-level (equipment) fault are made apparent in EID information displays.

To achieve the goals specified at the Functional Purpose level, overall mass movement between systems must be balanced. According to the law of conservation of mass, the mass flow into a system must equal the mass flow out. The relationship was illustrated with mass balance bars as shown in Figure 18 and is accentuated by the emergent features located between the bars: a horizontal line and a bubble. The mass balance bars are divided in a manner to show flow destinations. When the system is operating within work environment constraints, the two bars are equal in height and the horizontal line is flat. Should mass flow become uneven, e.g. leakage, the horizontal line

will tilt and the bubble will slide upwards along the line. The bubble graphical element is analogous to a carpenter’s level, which provides a visual indication of the mass flow rate of change.

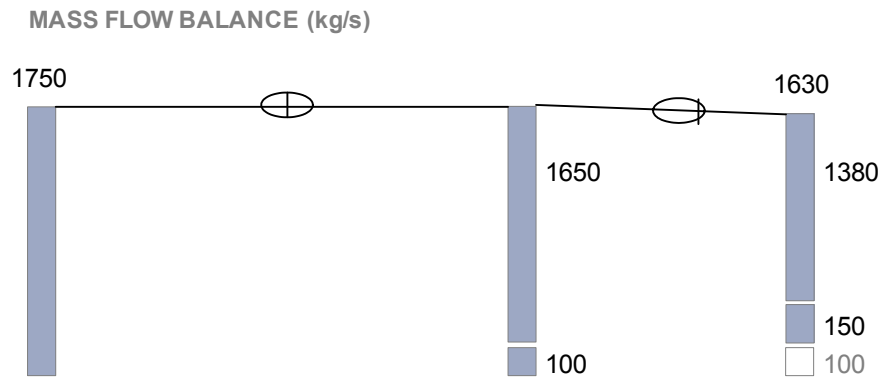

Figure 18: Mass Balance Graphic at Abstract Function Level

At the same time, it is vital that energy flow through the system remains within physical constraints as dictated by the first and second laws of thermodynamics. Steam energy is represented by enthalpy or heat content and varies across the turbine system based on the processes described at the Generalized Function level. Nuclear power plant control room operators are typically trained to use fundamental thermodynamic tools such as steam tables and Mollier diagrams to solve complex process related problems (Ontario Power Generation, 1988). However, such tools are often only available in hardcopy format and not integrated into the monitoring system. In applying the SRK framework, it is at times best to adapt existing visual representations of complex relationships to develop knowledge-based behaviour. The Mollier diagram in Figure 19 illustrates the expected changes in energy as steam flows through the system. The shape formed by the connecting lines offers a visualisation of the energy flow and more importantly a pattern that operators can recognise over time. Unfortunately, there are no practical means for measuring or calculating entropy (x-axis) in existing nuclear power plants. By adapting the Mollier diagram into a horizontal enthalpy profile, it was possible to retain the general shape and pattern of the flow (see Figure 20). Note that entropy is an ever-increasing value in a system and for the purposes of visualisation (i.e. not precise

calculations) it is reasonable to substitute the x-axis with a horizontal view of the turbine system.

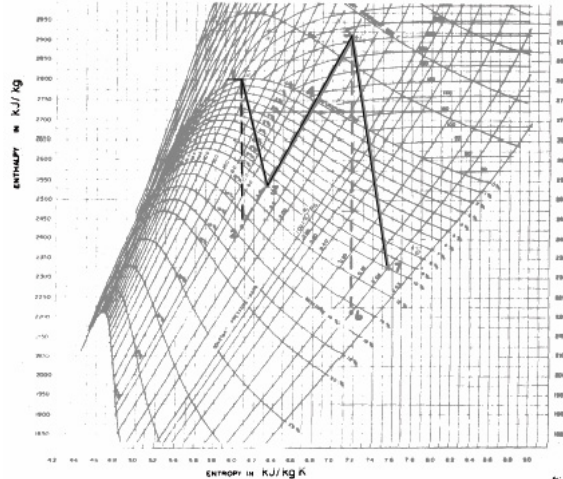

Figure 19: Mollier Diagram of Typical Energy Flow in Turbine System (Ontario Power Generation, 1988)

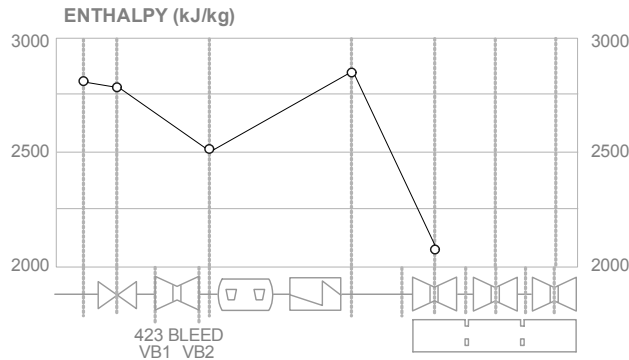

Figure 20: Energy Flow Profile at Abstract Function Level

3.3.2.3 Design at the Generalized Function Level

On the steam side of the turbine system, variables found at the Generalized Function level were associated with steam temperature and pressure. Similar to enthalpy at the Abstract Function level, temperature and pressure are related to one another through a sequence of processes. It was therefore possible to integrate horizontal temperature and pressure profiles (see Figure 21) with the enthalpy profile. Again, pattern recognition may be used by operators over time to detect changes in the system, but additional

graphical features were included since temperature and pressure constraints differ along the measurement points. Expected temperature and pressure values based on the current reactor load (i.e. electrical power generation set point) are represented with blue diamonds, which are consistent with the set point indicators in the valve position display. Current values, shown as white dots, are monitored to determine deviations from the set points. Alarm thresholds for each of the variables warn of approaching maximum or minimum limits via existing severity colours: yellow (low) and red (high).

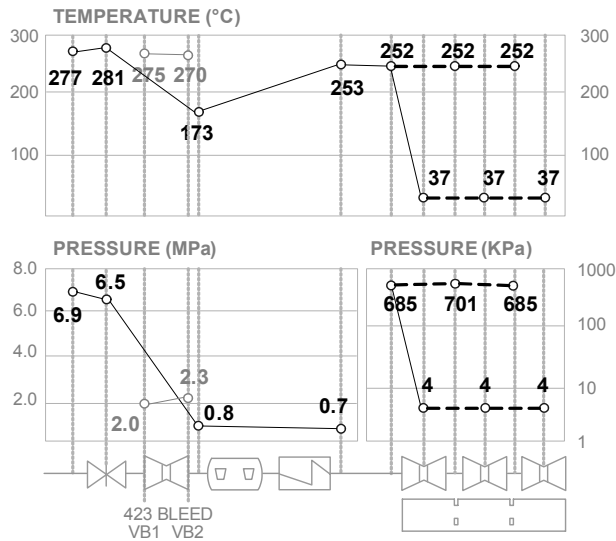

Figure 21: Temperature and Pressure Profiles at Abstract Function Level

On the electrical side of the turbine system, variables found at the Generalized Function level are related to the generation and transmission processes of electrical energy. The graphical form depicted in Figure 23 is intended to replace an indicator known as a synchroscope (see Figure 22) for the process of grid synchronisation. The breaker is closed to connect the generator and the grid when both sides have equal voltage magnitude, frequency, and phase. In a traditional synchroscope, operators are required to remember how each variable is mapped to the dial, e.g. position, direction, speed (for full details refer to Canadian Nuclear Safety Commission, 2003). To lessen the cognitive load on the operators during the synchronisation process, the differences between the variables were visualized. Voltages were portrayed as sinusoidal waves; when the generator-side sinusoidal wave (dark grey) matches the grid-side sinusoidal

wave (light grey), the system is synchronized. For saliency, the peaks of the waves were marked with white dots and blue diamonds, which were consistent with the other graphical forms designed for the system. Specific differences in the voltage magnitude, frequency, and phase were represented by trapezoidal shapes.

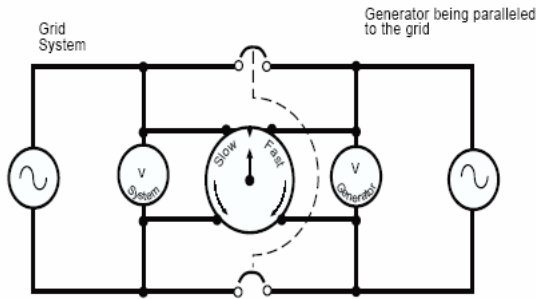

Figure 22: Traditional Sychroscope Indicator (Canadian Nuclear Safety Commission, 2003)

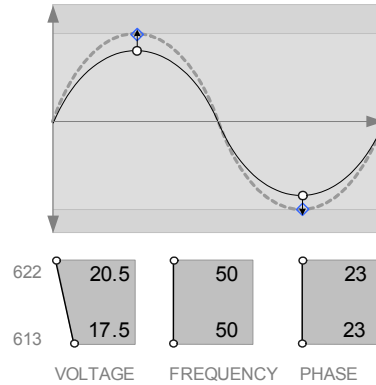

Figure 23: Grid Synchronisation Graphic at Generalized Function Level

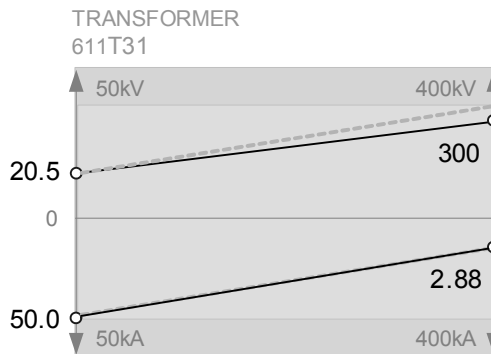

Figure 24: Voltage Conversion Graphic at Generalized Function Level

The voltage conversion process carried out by transformers is typically monitored through digital or independent values without reference to constraints. The variables involved in the process are related by a set transformer ratio value, which can be represented by a simple geometric shape (parallelogram) as shown in Figure 24. A step-up in voltage should result in a current reduction by the same amount based on the set transformer ratio. Voltage values are shown in the upper half of the graphical form, while amperage (current) values are shown in the lower half on a positive increasing vertical

scale. Note that the right vertical axis uses a logarithmic scale to account for the large step-up ratio. Again, the primary purpose of the graphic is to reduce the amount of mental calculations involved to determine whether the voltage and current values are within constraints.

3.3.2.4 Design at the Physical Function and Physical Form Levels

Equipment-relevant information such as capacity, size, and location are extracted from the Physical Function and Physical Form levels. Tanks identified in the part-whole decomposition analysis are constrained by maximum and minimum limits. Although the design of the displays underwent several iterations, the graphical forms characterising the tanks remained relatively constant (see Figure 25). The tank level traces behaved similarly to the reactor pressure trace (see Figure 13) described at the Functional Purpose level. The left side of the graphic displays the history of the water level in meters, but at a higher resolution, i.e. enlarged light grey portion of the right side. The right side of the graphic displays the current value of the variable as well as the alarm thresholds and capacity limits. Compact versions of the tank graphical forms were integrated into the mimic displays explained later in this subsection.

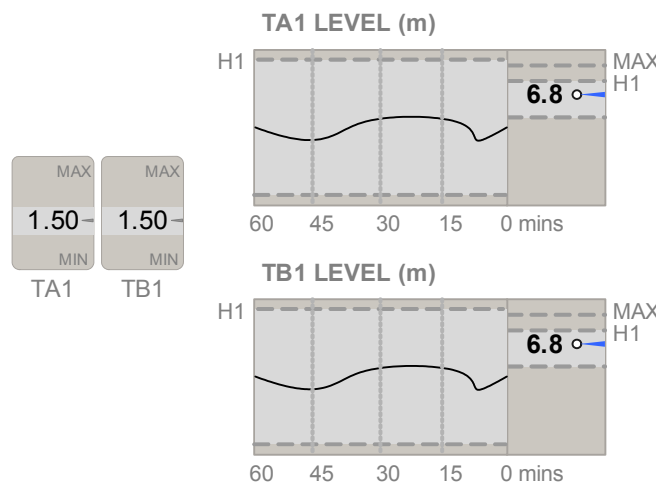

Figure 25: Tank Graphics at Physical Function Level

The turbine system consists of a high-pressure turbine and three low-pressure turbines, which contribute largely to the processes described at the Generalized Function

level, but are at the same time constrained by physical equipment limitations such as vibration described at the Physical Function level. The two vertical bars inside the turbine shape of the turbine vibration graphic (see Figure 26) are a visual indication of the maximum value; if the middle vertical black bar deviates or rotates too much, it will touch the two surrounding constraint bars. Under normal conditions, the middle bar is in the vertical position at or near the minimum value. Slight deviations to turbine vibration become apparent due to the two static constraint bars, which act as a reference and contribute to the graphic's emergent properties. It is important to note that some of the variables extracted at the Physical Function level are identical to others found at higher abstraction levels, e.g. valve positions, turbine speeds.

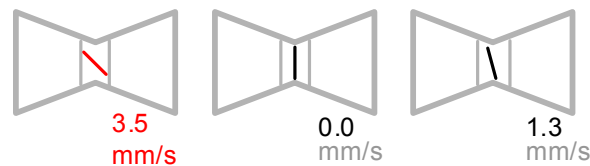

Figure 26: Turbine Vibration Graphic at Physical Function Level

As stated earlier, the AH analysis did not elaborate on the Physical Form details (equipment attributes, e.g. size, colour) found in plant literature for practical reasons. Much of the low-level information is available to operators in hardcopy format. Though it is not currently feasible to include such information in the simulator, the relative location of specific pieces of equipment can be approximated and visualized via mimic graphics. P&ID diagrams, part-whole models, and existing mimic displays (see Appendix A) were referenced and incorporated into the EID information displays; equipment was labelled accordingly. Some Physical Function graphics such as tanks and turbines were integrated into the mimic displays for conciseness. When operators interact with the mimic graphics, additional information regarding equipment state extracted at the Physical Function level becomes available. Operators may also remotely control certain pieces of equipment, in particular valves (e.g. open, close). However, all possible equipment actions were inherited from the existing mimic displays and were not examined in the EID analysis. The design of the EID information displays did not concentrate on controls, which were omitted from the system boundary.

3.3.3 Graphical Organisation

Graphical forms representing single and multiple variables were designed primarily in a manner to promote skill-based behaviour described in the SRK framework. In order to better support knowledge-based behaviour, the graphical forms designed in the above subsection were arranged based on the abstraction levels, i.e. embedding an AH representation of the system in the display (Vicente, 1999a; Burns, 2000). Variables derived at the Functional Purpose level such as reactor pressure and turbine control valve positions were placed in the upper portion of the display reflecting their actual positions in the hierarchy. Given that operators tend to visually scan items vertically from top to bottom in a supervisory control environment, it is also reasonable to arrange graphical elements representing the goals of the system near the top of the display (Wickens & Hollands, 2000). The balance, flow, and process variables were grouped by abstraction level and distributed throughout the mid-lower portion of the display. The mimic graphics were integrated with the higher abstraction graphics to facilitate means-ends visualisation. The integration of graphical forms from various levels has been shown to improve fault diagnosis times and accuracy (Burns, 2000). Equipment details at the Physical Form level including controls were made available on the left panel as a secondary display, e.g. valve information and controls appear on the left panel when a valve is selected in the main display.

The resulting EID information displays for the turbine secondary systems are shown in Figures 27 (main steam subsystem), 28 (steam reheat subsystem), and 29 (generator subsystem). The colours of the graphical forms were normalized across the three secondary systems to conform to the grey backdrop. Information displays utilising greyscale are known to improve salience of important graphical features (Burns & Hajdukiewicz, 2004). Graphical details such as line thickness, font type, and font size were also standardized for consistency. The displays were implemented using an in-house HMI design tool (Picasso) and tested in a pilot study. Many design changes were made

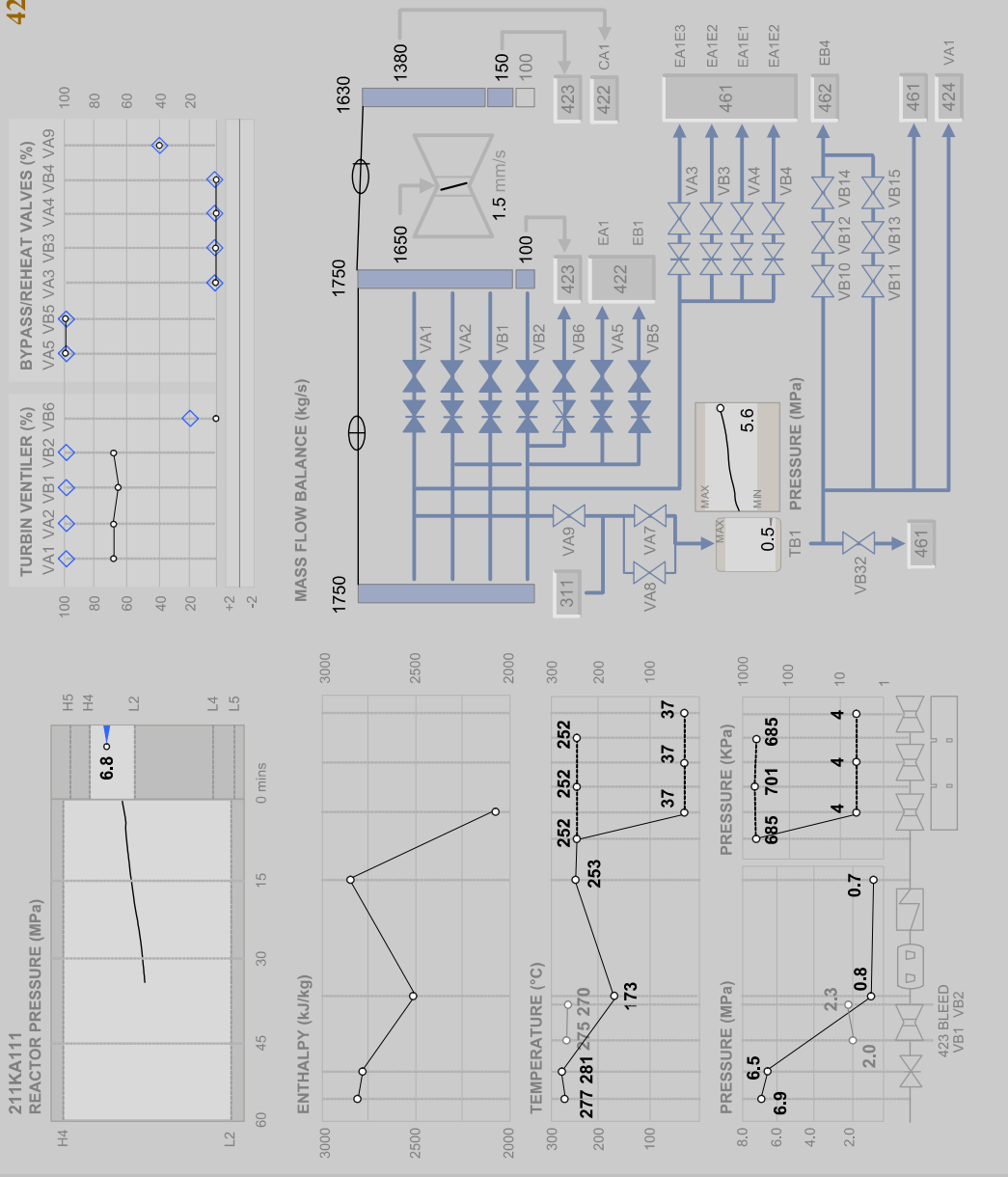

Figure 27: Main Steam Subsystem Display in the Turbine System

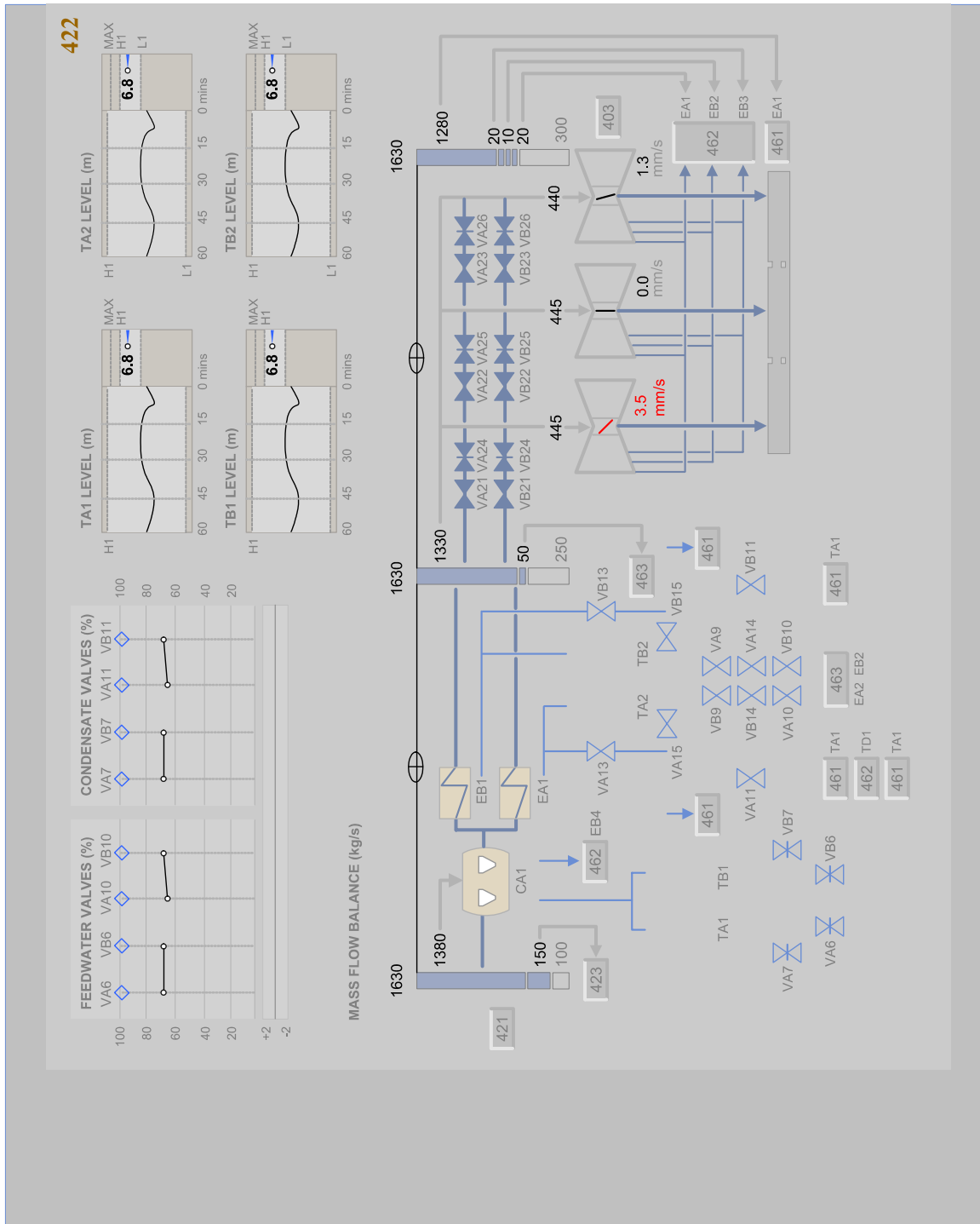

Figure 28: Steam Reheat Subsystem Display in the Turbine System

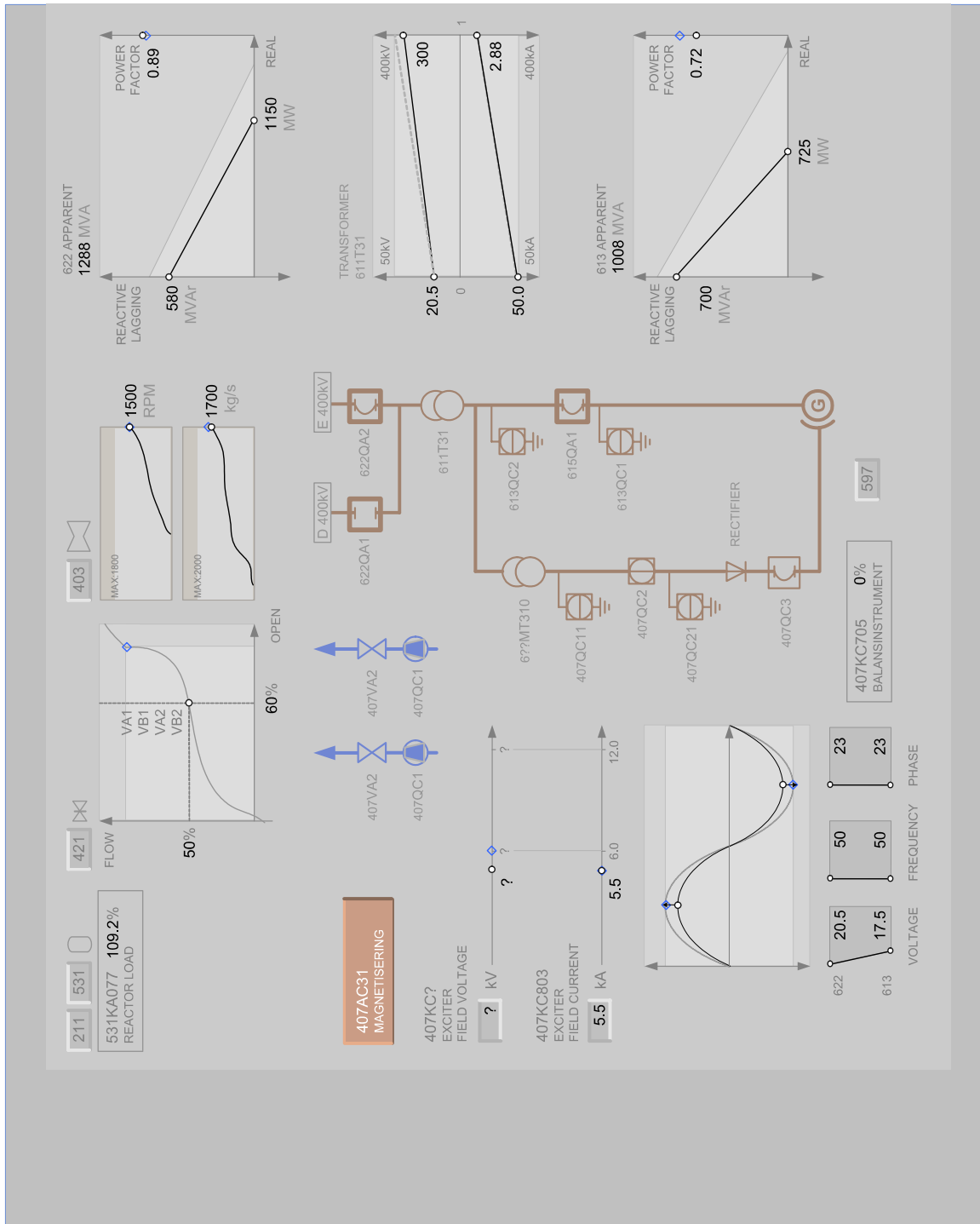

Figure 29: Generator Subsystem Display in the Turbine System

based on participant feedback as part of the iterative design process similar to other design approaches. The pre-pilot EID information displays for the turbine secondary systems are available for reference in Appendix E. The finalized post-pilot EID information displays for each of the secondary systems can be found in Appendix F; the displays were implemented in the HAMMLAB Forsmark 3 simulator and evaluated with trained operators as described in the following chapter.

Chapter 4

Methodology for Evaluating Ecological Interface Design and Situation Awareness

A comparative experiment was designed and subsequently conducted to evaluate the Ecological Interface Design (EID) information displays for the Forsmark 3 boiling water reactor nuclear power plant. Operator situation awareness (SA) and performance are of specific interest to the Halden Reactor Project (HRP). This thesis focuses primarily on measuring and comparing SA between the EID and existing mimic displays. Given the project's limited access to licensed operator participants from the Forsmark 3 plant, a number of experimental designs were examined via a power analysis for suitability. A pilot experiment was also carried out to verify the methodology. This chapter describes the experimental design used to test hypothesized effects based on prior research.

4.1 Participants

Participants for the experiment were recruited from the Forsmark 3 boiling water reactor nuclear power plant located in Sweden. The power plant licensee is a member of the Halden Reactor Project (HRP). A total of six ($n = 6$) licensed control room operating crews with roles ranging from supervision to reactor operation agreed to participate on a voluntary basis. Each crew consisted of one reactor operator (RO) and one turbine operator (TO). The study examines the role of the TO in particular, but crew is considered to be representative of a single working unit despite the absence of a shift supervisor (SS) found in a typical control room operating crew. Two additional operators were recruited for the pilot study. See Appendix I for complete materials concerning ethics, recruitment procedures, and scheduling.

4.2 Experimental Environment

As indicated in Chapter 2, the experiment was conducted at the Halden Man-Machine Laboratory (HAMMLAB). The HAMMLAB control room environment contains three workstations and a large-screen display as shown in Figure 30. The workstations transmit and receive data from one of three plant simulators: Forsmark 3, Fessenheim, and Oseberg Øst. The data is presented to the operators at each workstation through interfaces on 19" LCD panels. Navigation and interaction through the interfaces is done via keyboard and mouse. A typical control room experiment involves one reactor operator, one turbine operator, and one shift supervisor. In this particular experiment, the various interfaces and scenarios were evaluated with one reactor operator and one turbine operator. Each operator workstation is made up of 12 individual LCD panels. See Appendix H for complete details on screen set-up and organisation. The large-screen display in the middle of the room provides an overview of the plant for both operators. Located behind the control room environment shown in Figure 31 is an observation gallery from which the experimental team manages the simulator, scenarios, and data collection. Operator interactions with the interfaces are logged in the simulator while activities within the control room environment are audio and video recorded.

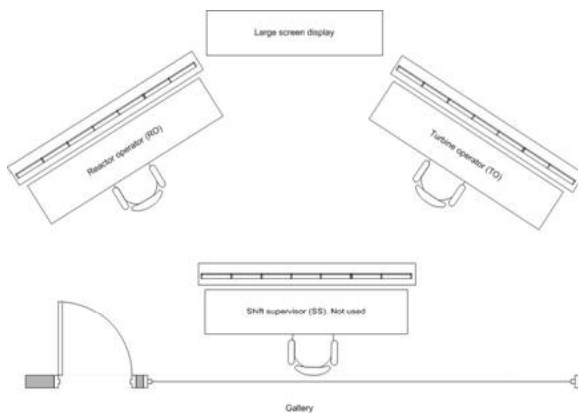

Figure 30: HAMMLAB Control Room Layout

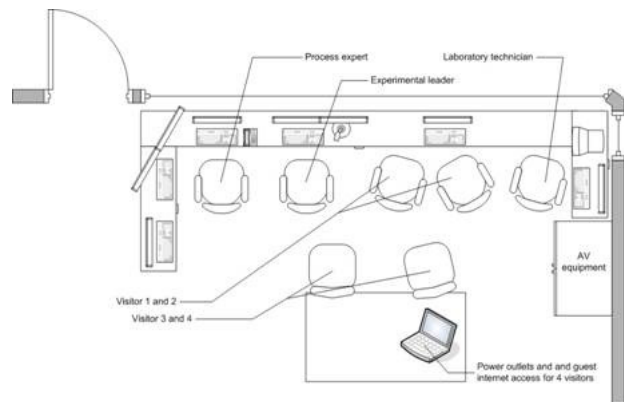

Figure 31: HAMMLAB Observation Gallery

The experimental team consisted of an experimental leader, a process expert, a laboratory technician, and a training team. The leader was responsible for overseeing the scenario progression, acting as a representative from plant management in order to

evaluate operator response, and administering the appropriate questionnaires. The process expert managed the simulator functions, acted as plant and engineering personnel, provided comments on the current state of the scenario. The laboratory technician handled all data recorded through the simulator, including questionnaires, and audio-visual equipment. See Section 4.6 for more details concerning experimental procedures such as training and run plan.

4.3 Experimental Design

To determine to what degree EID supports situation awareness, it is necessary to perform a comparative evaluation given that no industry benchmarks exist. In an ongoing man-machine systems project, the HRP is developing advanced displays primarily through a user-centred design (UCD) approach based on existing hardwired mimic displays in existing control rooms. Traditional mimic and advanced UCD displays for the Forsmark 3 nuclear power plant were evaluated alongside the EID information displays. In addition to examining operator situation awareness between the interfaces, potential differences from anticipated and unanticipated scenario types as well as scenario periods were investigated. Table 2 and 3 summarize the independent and dependent variables for this particular study.

The independent variables in this experiment were selected in order to investigate potential scenario effects on the different types of interfaces. Prior research suggests that EID information displays provide support for operator performance in unfamiliar and unanticipated scenarios (Vicente, 1999a). Furthermore, the EID approach directly supports fault detection and mitigation through visualisation techniques based on the SRK framework. The dependent variables include a variety of measures of interest of the HRP project as a whole. However, this thesis concentrates foremost on variables related to SA: SACRI, HOPE, and Self-Rated Bias. See Section 4.4 for hypotheses concerning the effects of interface type and scenario factors on operator SA.

A 3x2x2 within-subjects randomized block factorial (RBF-322) design, also known as a 3-way repeated measures design, was initially applied to the study. A within-subjects design was selected to control variances in factors such as learning between

operators. Furthermore, it allowed for limited (participant) resources to be employed in a manner that would yield conclusive results. See Section 4.5 for details concerning the power analysis conducted for this particular experimental design. A total of twelve (12) conditions were examined, i.e. crossing all independent variables. Because participants are evaluated for multiple conditions, it is important to counterbalance or randomize the presentation order. Counterbalancing prevents order effects such as learning or fatigue, which may confound the dependent measures. Given the small sample size of the study, it was not possible to perform complete counterbalancing via a repeated measures design in which participants are evaluated for all condition permutations. An incomplete balanced Latin square counterbalancing technique was employed to evenly distribute conditions among the participants; this approach compensates order and carry-over (sequential) effects.

Table 2: Independent Variables

Interface Type (A)	a ₁ : Ecological Interface Design (Appendix F) a ₂ : Advanced User Centred Design (Appendix A) a ₃ : Traditional Single Sensor-Single Indicator
Scenario Type (B)	b ₁ : Anticipated Scenario b ₂ : Unanticipated Scenario
Scenario Period (c)	c ₁ : Detection Phase c ₂ : Mitigation Phase

Table 3: Dependent Variables

SACRI	<ul style="list-style-type: none"> • Situation Awareness Control Room Inventory based on SAGAT and SDT (see Chapter 2) • Post-experiment scoring via simulator log comparison replaced with concurrent scoring performed by process expert during scenario breaks. • Modification avoids need to reconstruct events thus streamlining scoring process.
HOPE	<ul style="list-style-type: none"> • Halden Open Probe Elicitation (see Chapter 2)
OPAS	<ul style="list-style-type: none"> • Operator Performance Assessment System (Skraaning, 1998, 2003)
Self-Ratings	<ul style="list-style-type: none"> • Self-Rated Bias (Situation Awareness) • Self-Rated Task Complexity (Workload) • Self-Rated Operator Performance

In designing the Latin square, only the independent variables that have the potential to confound results through order effects were counterbalanced. Combinations of interface type and scenario type variables formed six conditions: a_1b_1 , a_1b_2 , a_2b_1 , a_2b_2 , a_3b_1 , and a_3b_2 . Scenario period was excluded from the Latin square design, as the detection phase always preceded the mitigation phase. The six conditions were systematically randomized in a 6x6 square made up of six crews and six scenario runs. In essence, each crew is assigned a different condition presentation order. See Table 8 in Section 4.6 for the resulting run plan. For each scenario type (anticipated, unanticipated), three different versions were designed and randomly distributed within the run plan. Table 4 below gives a general description of each scenario used in the experiment.

Table 4: Scenario Descriptions

Scenario Type	Version	Description
Anticipated (b_1)	1	Leak in intermediate super heater (422EA1) causes high-pressure steam to flow to low-pressure turbines.
	2	Malfunction in drain valve (463VA20) prevents water from draining to the condenser.
	3	Malfunction in level regulating valve (463VB21) causes excessive drain flow.
Unanticipated (b_2)	1	Turbine trip due to malfunction in drain valve (422VB6) with the generator still connected to the grid.
	2	Leak in condensate cleaning building (KRA332) due to malfunction in drain valve (332VB2).
	3	High seawater temperature causes an increase in pressure and temperature in the condenser.

4.4 Hypotheses

To test the overall main and interaction effects of the variables described above, the experiment employed non-directional hypotheses (Skraaning Jr., Nihlwing, Welch, & Veland, 2005a). However, directional expectations were examined post-experimentally through contrast analyses. It should be noted that this thesis concentrates mainly on the effects of interface type and scenario type. The effects of scenario period are not hypothesized, but discussed separately. Refer to Table 2 for designated treatment level symbols and Table 5 for a summary of the hypotheses in symbolic form.

Hypothesis for main effect of interface type (A): Results from existing empirical studies (Vicente, 2002) suggest performance advantages of EID information displays over traditional interfaces designed primarily through the Single Sensor-Single Indicator (SS-SI) approach (Goodstein, 1981). Comparisons of EID information displays to advanced interfaces designed with other progressive methodologies such as Task-Based and UCD have also yielded EID performance gains (Burns and Hajdukiewicz, 2004). Although there have been no prior studies examining the effects of the EID approach on operator SA, similar results are expected. *It is hypothesized that a significant difference exists between mean SA scores (m) in the different treatment levels. In particular, mean SA scores for the EID interface type will be significantly greater than mean SA scores for the Advanced UCD and Traditional SS-SI interface types.*

Hypothesis for main effect of scenario type (B): Investigations into past incidents in the process control domain have revealed that system safety is often compromised by operators' inability to adapt to new and unfamiliar situations (Vicente & Rasmussen, 1992). Such situations are also known as beyond-design-basis or unanticipated events; events that interfaces and training programs cannot be specifically designed to support. Again, although there have been no prior studies examining the effects of unanticipated events on operator SA, similar results are expected. *It is hypothesized that a significant difference exists between mean SA scores (m) in the different treatment levels. In particular, mean SA scores for anticipated scenarios will be significantly greater than mean SA scores for unanticipated scenarios.*

Hypothesis for interaction effect between interface type (A) and scenario type (B): EID information displays have been shown to improve operator performance in unanticipated events (Vicente, 1999a). The results have been replicated in a representative industrial environment, i.e. full-scope simulator study with professional participants (Jamieson, 2002). EID aims to support beyond-design-basis events by making information relevant to event detection and problem solving visible to the operator. *It is hypothesized that a significant difference exists between mean SA scores (m) for some treatment combination, i.e. A x B. Because within-design-basis or anticipated events are typically directly supported in process control systems, no significant difference in operator SA is expected between the interfaces. Given that the EID*

information displays are designed to directly support knowledge-based processing under all event types, it is hypothesized that the mean SA score is significantly higher. However, if the Advanced User Centred Design (UCD) information displays provide similar support for specific unanticipated events, the mean SA score will be comparable to that of the EID information displays and greater than that of the Traditional SS-SI information displays. Likewise, if the Advanced UCD information displays do not adequately support unanticipated events, the mean SA score will be significantly less than that of the EID information displays and equal to that of the Traditional SS-SI information displays.

Table 5: Summary of Hypotheses

Interface Type (A)	$H_0: m_{a1} = m_{a2} = m_{a3}$ $H_1: m_i \neq m_j$ for some i and j (non-directional) $H_1: m_{a1} > m_{a2} > m_{a3}$ (directional)
Scenario Type (B)	$H_0: m_{b1} = m_{b2}$ $H_1: m_{b1} \neq m_{b2}$ (non-directional) $H_1: m_{b1} > m_{b2}$ (directional)
Interface Type (A) x Scenario Type (B)	$H_0: m_{ij} - m_{i'j} - m_{ij'} - m_{i'j'} = 0$ for all treatment combinations $H_1: m_{ij} - m_{i'j} - m_{ij'} - m_{i'j'} \neq 0$ (non-directional) $H_1: m_{a1b1} = m_{a2b1} = m_{a3b1} > m_{a1b2} \geq m_{a2b2} \geq m_{a3b2}$ (directional)

4.5 Power Analysis

A power analysis was carried out by a team of experts (Skraaning Jr., Nihlwing, Welch, & Veland, 2005a) to estimate the probability that the proposed experimental design would produce statistically significant results. Specifically, power was estimated for the main effects of interface type (A), scenarios type (B), and scenario period (C) produced by the within-subjects RBF-322 design. Calculations were performed using the Power Analysis and Sample Size (PASS) software (Hintze, 1994). Parameters required and assumptions made for the analysis are described below.

Power is determined by several factors, namely: alpha (α) level, sample size (n), and effect size (f, ω^2). The levels of statistical significance are $\alpha = 0.05$ (moderate evidence against H_0) and $\alpha = 0.10$ (suggestive evidence against H_0). The p-value approach is employed with the convention indicated in Table 6. As previously noted, the hypotheses are assumed to be non-directional and thus two-tailed significance tests are

used. The population correlation coefficient among treatment combinations, i.e. degree of association between all treatments, is assumed to be $\rho = 0.25$ (moderate estimate) based on previous HAMMLAB studies. A sample size of $n = 6$ was used in the calculations, reflecting the limited number of participants. Power was estimated for three effect sizes or degree to which null hypothesis is false: medium ($f = 0.25$, $\omega^2 = 0.059$), typical ($f = 0.33$, $\omega^2 = 0.10$), and large ($f = 0.40$, $\omega^2 = 0.138$). In this case, f is a measure of difference and ω^2 is a measure of association. A medium effect size is characterized by differences noticeable through careful observation, while a large effect size is immediately apparent (Cohen, 1992). A typical effect size refers to experimental effects that are generally reported in the field of behavioural science (Rosenthal, Rosnow, & Rubin, 2000).

Table 6: P-Value Interpretations for Power Analysis

p-value	Interpretation
$p < 0.01$	Very strong evidence against H_0 .
$0.01 \leq p < 0.05$	Moderate evidence against H_0 .
$0.05 \leq p < 0.10$	Suggestive evidence against H_0 .
$p \geq 0.10$	Little or no evidence against H_0 .

Table 7: Power Estimates for RBF-322 (Skraaning Jr., Nihlwing, Welch, & Veland, 2005a)

RBF-322	Large Effects		Typical Effects		Medium Effects	
	$\alpha = 0.05$	$\alpha = 0.10$	$\alpha = 0.05$	$\alpha = 0.10$	$\alpha = 0.05$	$\alpha = 0.10$
Interface Type	<i>0.94</i>	<i>0.98</i>	<i>0.82</i>	<i>0.91</i>	0.51	0.72
Interface Type (GG-HF)	<i>0.91</i>	<i>0.97</i>	0.77	<i>0.89</i>	0.51	0.69
Interface Type (Multivariate)	0.67	<i>0.84</i>	0.51	0.70	0.32	0.50
Scenario Type	<i>0.94</i>	<i>0.99</i>	<i>0.84</i>	<i>0.94</i>	0.63	0.79
Scenario Period	<i>0.94</i>	<i>0.99</i>	<i>0.84</i>	<i>0.94</i>	0.63	0.79

The resulting power estimates are provided in Table 7. In general, an experimental design yields significant effects when power is estimated to be at least 0.80; these values are italicised. It can be concluded from Table 7 that the proposed RBF-322 experimental design with sample size of $n = 6$ has sufficient statistical power to reveal typical and large effects. For medium effects, there may be suggestive evidence against

H_0 given that the power estimates are close to 0.80. The Greenhouse-Geisser/Huynh-Feldt adjustment and multivariate approach to repeated measures were included for the interface type (A) treatment. However, the Greenhouse-Geisser/Huynh-Feldt adjustment is preferred over the multivariate approach in this case.

4.6 Procedure

Due to the nature of the experiment, i.e. involving human participants, the proposed study and recruitment process were first cleared by three separate ethics committees (one from each participating institution): Office of Research Ethics (University of Waterloo), Ethics Review Office (University of Toronto), and Human Studies Review Committee (IFE). Recruitment and scheduling materials submitted to the ethics boards are provided in Appendix I.

A total of six crews consisting of a reactor operator and a turbine operator were invited to participate in the study. The experiment was conducted over a span of three weeks, i.e. two crews per week. Each week comprised of three days of training and evaluation. A one-day training session at the start of the week was held to familiarize the operators with the HAMMLAB facilities, the Forsmark 3 simulator, and the information displays. A background demographics questionnaire was also distributed during the training session. Scenario trial sessions were held in the following two days of the week. Table 8 details the overall run plan of the experiment based on the design described in the preceding sections. Each crew was assigned to six different scenario-interface combinations, which were presented in random order. Refer to Table 2 for designated treatment combination symbols. Numbers shown in brackets represent the scenario version for the corresponding scenario type as described in Table 4. To prevent fatigue, each crew was limited to three scenarios per day. For a daily run down of activities, refer to Appendix I.

Following the measurement strategies outlined in existing SACRI and HOPE literature, questionnaires and probes were administered at random time intervals during each scenario. Specifically, two pauses are made per scenario during which the screens are blanked and the operators are asked to fill out a questionnaire, i.e. SACRI and self-

rating. The first pause is made sometime during the detection phase while the second pause is made after the mitigation phase. During the pause in the detection phase, operators answered 4 self-rating questions and between 9 to 12 SACRI queries. During the pause in the mitigation phase, operators answered 8 self-rating questions and 12 SACRI queries. Similar simulator pauses without screen blanking are made throughout the scenario during which the experimental leader probes an operator's SA through telephone conversation, i.e. HOPE. A total of four HOPE queries were made per scenario: (1) during detection phase, (2) immediately after detection phase, (3) during mitigation phase, and (4) immediately after mitigation phase. A debriefing session was held upon the completion of all scenarios to gather other potentially helpful information such as user satisfaction. Refer to Appendix J for a compilation of questionnaires used in the experiment. As previously mentioned, data relevant to the hypotheses were primarily collected through the simulator and audio-visual instruments. The analysis and results of the data are detailed in the following chapter.

Table 8: Experiment Run Plan (Skraaning Jr., Nihlwing, Welch, & Veland, 2005a)

	Run Order					
	1	2	3	4	5	6
Crew 1	a ₁ b ₁ (2)	a ₃ b ₂ (2)	a ₂ b ₂ (3)	a ₁ b ₂ (3)	a ₃ b ₁ (1)	a ₂ b ₁ (1)
Crew 2	a ₂ b ₁ (2)	a ₁ b ₁ (1)	a ₃ b ₂ (3)	a ₂ b ₂ (2)	a ₁ b ₂ (1)	a ₃ b ₁ (3)
Crew 3	a ₃ b ₁ (3)	a ₂ b ₁ (2)	a ₁ b ₁ (2)	a ₃ b ₂ (1)	a ₂ b ₂ (3)	a ₁ b ₂ (1)
Crew 4	a ₁ b ₂ (1)	a ₃ b ₁ (3)	a ₂ b ₁ (3)	a ₁ b ₁ (1)	a ₃ b ₂ (2)	a ₂ b ₂ (2)
Crew 5	a ₂ b ₂ (3)	a ₁ b ₂ (2)	a ₃ b ₁ (1)	a ₂ b ₁ (3)	a ₁ b ₁ (2)	a ₃ b ₂ (1)
Crew 6	a ₃ b ₂ (1)	a ₂ b ₂ (2)	a ₁ b ₂ (3)	a ₃ b ₁ (3)	a ₂ b ₁ (2)	a ₁ b ₁ (1)

Chapter 5

Data Analysis and Results

This chapter provides the results of the statistical analyses carried out on the data collected in the comparative experiment. Non-directional (two-tailed) tests were employed. Particular attention is given to data relevant to the proposed hypotheses described in Chapter 4, i.e. self-rating bias, Halden Open Probe Elicitation (HOPE), and Situation Awareness Control Room Inventory (SACRI). The preliminary results suggest that no significant differences in operator situation awareness (SA) exist between the three information displays. However, several interaction effects were found between the three independent variables. In particular, SACRI sensitivity scores for the different interfaces were found to depend on scenario type. The HOPE and SACRI measures also suggested differences in operator SA while proceeding from the detection phase to the mitigation phase. Analyses in this chapter were performed using SPSS.

5.1 Demographics

A total of six (6) licensed control room operating crews were recruited from the Forsmark 3 boiling water reactor plant in Sweden. A typical control room crew consists of one reactor operator (RO), one turbine operator (TO), and one shift supervisor (SS).

However, due to the Halden Reactor Project's limited access to qualified individuals, a SS was not included in the crews. The demographic details gathered from the background questionnaire of the twelve (12) participants are given in Table 5.1. Refer to Appendix I.B for a copy of the background questionnaire. Due to unforeseen circumstances, two (2) of the participants scheduled to act as reactor operators for the experiment were unable to attend. Replacing the absentees with participants from other crews was considered to be

the least intrusive option given that the complete removal of two crews from the experiment would alter the power of the results significantly. Specifically, participants 1 and 5 acted in place of participants 3 and 7 (shown in Table 9), respectively.

Table 9: Demographics Results

ID	Role	Current Position	HAMMLAB Experience	Age	Sex	Licenses / Years in Position		
						TO	RO	SS
1	RO	SS	0	59	M	N / 5	Y / 3	Y / 13
2	TO	TO / RO	1	53	M	Y / 10	Y / 5	N / 0
3	RO	SS	0	59	M	N / 5	Y / 3	Y / 13
4	TO	RO / Shift Eng.	3	44	M	N / 0	Y / 14	Y / 0
5	RO	SS	5	46	M	N / 2	Y / 14	Y / 9
6	TO	RO	0	38	M	N / 5	Y / 5	Y / 2
7	RO	SS	5	46	M	N / 0	Y / 14	Y / 9
8	TO	TO	2	37	M	Y / 3	N / 0	N / 0
9	RO	RO / SS	2	47	M	N / 5	Y / 10	Y / 2
10	TO	Other	0	48	M	N / 0	N / 0	N / 0
11	RO	RO / Shift Eng.	2	46	M	N / 15	Y / 8	Y / 3
12	TO	TO / RO	0	39	F	Y / 2.5	Y / 0.5	N / 0
Mean			1.50	45.7	9M, 1F	3 / 4.75	8 / 5.95	6 / 2.9
Standard Deviation			1.65	6.83		4.64	5.39	4.51

A majority of the operators have prior experience with the HAMMLAB simulator and facilities; overall average of 1.5 years of involvement with the HRP. The mean age of the participants was 45.7 with a standard deviation of 6.83. Of the ten (10) unique participants, less than half possessed a turbine operator license, while a majority held a reactor operator license. As per regulatory guidelines, licenses require continual renewal in order to be valid. Half of the operators are former turbine operators and no longer possess a valid turbine operator license. The mean number of years of experience in each of the positions relevant to the study: 4.75 (TO), 5.95 (RO), and 2.9 (SS). It should be noted that participant 10 has no prior official control room operating experience, but has extensive experience as a field operator and control room instructor.

5.2 Self-Rated Bias

A self-rating questionnaire was administered to the operators during the detection and mitigation phases in each scenario, i.e. during the same scenario breaks required for the SACRI measure. Similar to the HOPE measure, self-rated bias attempts to subjectively

assess SA. However, self-rated bias as applied in this study directly probes operator SA, whereas HOPE relies on expert evaluators to indirectly score SA based on operator response to open verbal queries. Refer to Appendix J for a copy of the self-rating bias questionnaire. Participants rate themselves on a scale of 1 to 5 for each question, of which two directly measure SA: (1) *I had a good overview of the process*, and (2) *I became aware of process deviations at an early stage*. The ratings from the two questions translate roughly to an overall SA score, where a score of 1 is representative of poor SA and 5 is of perfect SA. The following analysis exclusively examines the self-ratings extracted from the two SA-relevant questions by turbine operators.

Table 10: Self-Rated Bias Summary

	Interface Type			Scenario Type		Scenario Period	
	a ₁	a ₂	a ₃	b ₁	b ₂	c ₁	c ₂
Mean	3.287	3.318	3.089	3.254	3.208	3.340	3.123
Standard Deviation	0.5857	0.5793	0.7047	0.5554	0.6957	0.6385	0.6010
Maximum	4.25	4.00	4.50	4.25	4.50	4.50	4.00
Minimum	2.00	1.75	1.75	2.00	1.75	1.75	1.75

Table 11: Self-Rated Bias ANOVA

Effect	SS	df	Mean Square	F	p
Interface Type (A)	0.741	1.611	0.460	1.070	0.371
Scenario Type (B)	0.037	1	0.037	0.730	0.432
Scenario Period (C)	0.861	1	0.861	3.830	0.108
AxB	0.189	1.507	0.126	0.430	0.612
AxC	0.880	1.185	0.743	1.476	0.280
BxC	0.521	1	0.521	3.755	0.110
AxBxC	1.616	1.451	1.114	2.721	0.137

A summary of self-rated bias categorized by interface type (A), scenario type (B), and scenario period (C) is provided in Table 10 and Figure 32. An analysis was performed to determine the main effects of the three independent variables. The interaction effects among the independent variables were also examined. The results of a 3-way repeated measures analysis of variance (ANOVA) with Greenhouse-Geisser corrections where appropriate are shown in Table 11. Residual plots of the data indicate that the assumptions of constant variance among groups and normality in each combination hold. No significant main effects or interactions were found, $p > 0.10$ for all conditions. Self-rated bias appears to average around 3 (on a scale of 1 to 5) regardless of

treatment, which is representative of moderate operator SA. Essentially, there is no evidence that interface type (A), scenario type (B), and scenario period (C) have any effect on an operator’s self-rated bias, i.e. SA is neither improved nor degraded.

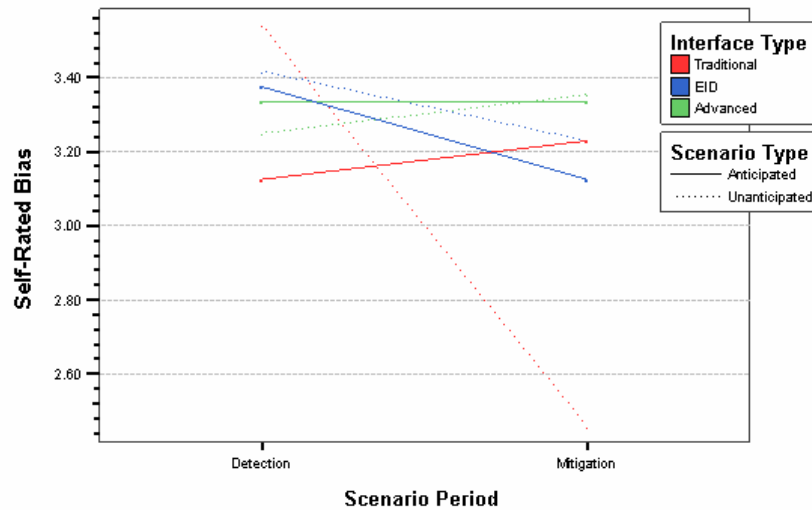

Figure 32: Mean Self-Rated Bias

5.3 Halden Open Probe Elicitation (HOPE)

As described previously in Chapter 2, the Halden Open Probe Elicitation (HOPE) measure assesses operator SA on a scale known as operator Level of Understanding (LoU). The LoU score for an operator is determined by an expert observer acting as a representative from plant management via a series of queries or open probes. Recall that the measure was administered by telephone. Refer to Appendix G for a description of the LoU scale and Appendix J for HOPE query timelines per scenario and condition probes. A total of four probes were made per scenario: (1) during detection phase, (2) immediately after detection phase, (3) during mitigation phase, and (4) immediately after mitigation phase. The exact span of time in between each probe depends on the scenario; however, the four probes always occur in succession.

A summary of turbine operator HOPE LoU scores categorized by interface type (A), scenario type (B), and scenario period (C) is provided in Table 12 and Figure 33. A maximum score of 3 (full understanding) and a minimum score of 1 (poor understanding)

was given for all variable levels. An analysis was performed to determine the main effects of the three variables as well as possible interaction effects. The results of a 3-way repeated measures ANOVA with Greenhouse-Geisser corrections where appropriate are shown in Table 13. Residual plots of the data show that the assumptions of constant variance among groups and normality in each combination hold.

Table 12: HOPE Level of Understanding Summary

	Interface Type			Scenario Type		Scenario Period			
	a ₁	a ₂	a ₃	b ₁	b ₂	1	2	3	4
Mean	1.380	1.210	1.350	1.320	1.310	0.670	1.220	1.780	1.580
Standard Deviation	1.003	0.922	1.082	0.976	1.030	0.986	1.124	0.722	0.770
Maximum	3	3	3	3	3	3	3	3	3
Minimum	0	0	0	0	0	0	0	0	0

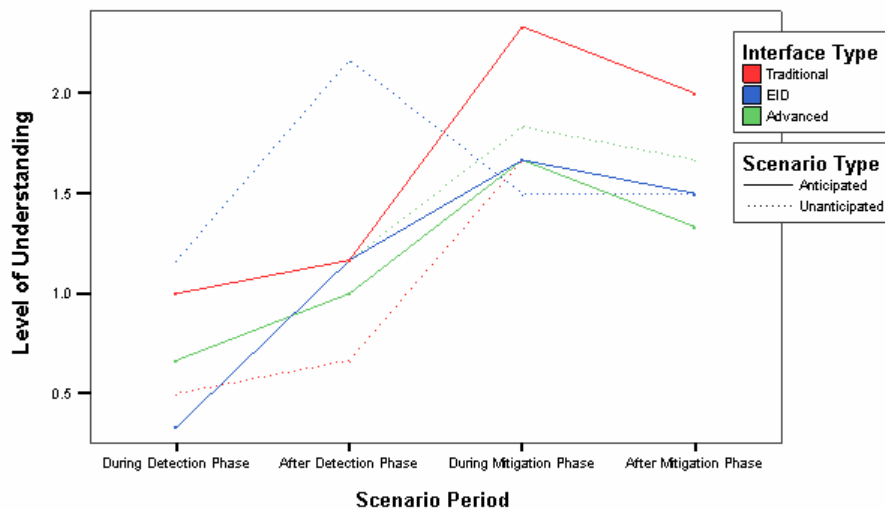

Figure 33: Mean HOPE Level of Understanding

No main effects or interactions were found for the interface type (A) and scenario type (B) conditions, $p > 0.10$ for all combinations. Operators under all interface and scenario type treatments yielded similar mean LoU scores of approximately 1.3 points (on a scale of 0 to 3), which corresponds to some understanding of the situation or SA. There is strong evidence that a difference in LoU scores exists over time, from the detection phase to the mitigation phase [$F(2.137, 10.686) = 10.91, p = 0.002$]. A general increase in the scores with a slight drop after the mitigation phase can be seen in Figure 33. A pre-planned polynomial contrast of scenario period (C) revealed a quadratic effect

over time [$F(1, 5) = 20.593, p = 0.006$]. The drop in LoU at the end of each scenario occurs in a consistent manner across all conditions. However, there was no evidence of interaction effects with time.

A separate analysis averaging the two detection phase scores (probes 1 and 2) and the two mitigation phase scores (probes 3 and 4) was conducted to determine if an overall difference in LoU existed between the two phases. Again, strong evidence was found indicating a significant increase in LoU scores when operators are proceeding from the detection phase to the mitigation phase. A general mean increase of 0.736 points was observed; it is often enough to raise an operator’s understanding of a situation by a level based on the HOPE LoU scale. In this case, an operator acquires some SA in the detection phase and gains a level of understanding equivalent to good SA in the mitigation phase.

Table 13: HOPE Level of Understanding ANOVA

Effect	SS	df	Mean Square	F	p
Interface Type (A)	0.792	2	0.396	0.397	0.682
Scenario Type (B)	0.007	1	0.007	0.031	0.867
Scenario Period (C)	25.74	2.137	12.05	10.91	<i>0.002</i>
AxB	5.681	1.095	5.186	1.530	0.271
AxC	4.986	2.608	1.912	1.210	0.340
BxC	0.910	1.316	0.691	0.435	0.586
AxBxC	2.986	1.936	1.543	1.923	0.198

5.4 Situation Awareness Control Room Inventory (SACRI)

The Situation Awareness Control Room Inventory (SACRI) measure attempts to directly assess SA based on operator accuracy in detecting deviations in the system. More specifically, a score is calculated using Signal Detection Theory (SDT). The number of hits, misses, false alarms, and correct rejections in each scenario are used to calculate sensitivity (A') and response bias ($R:S$). Refer to Appendix K for the corresponding formulae. Similar to the administration of the self-rated bias questionnaire, a SACRI inventory of queries was provided to operators at a random time during the detection phase as well as after the mitigation phase for each scenario. The queries are pre-selected

for each scenario, but presented in a random order. Operators are asked whether certain parameters (e.g. tank level, valve opening, steam pressure) are increasing, decreasing, or constant. A complete list of relevant parameters for each scenario is provided in Appendix J.

Table 14: SACRI Sensitivity (A') Summary

	Interface Type			Scenario Type		Scenario Period	
	a ₁	a ₂	a ₃	b ₁	b ₂	c ₁	c ₂
Mean	0.5914	0.7246	0.4856	0.6985	0.5025	0.7382	0.4728
Standard Deviation	0.5268	0.1917	0.5450	0.2257	0.5922	0.2002	0.5897
Maximum	1.00	1.00	0.97	0.95	1.00	1.00	1.00
Minimum	-0.96	0.29	-0.96	0.08	-0.96	0.29	-0.96

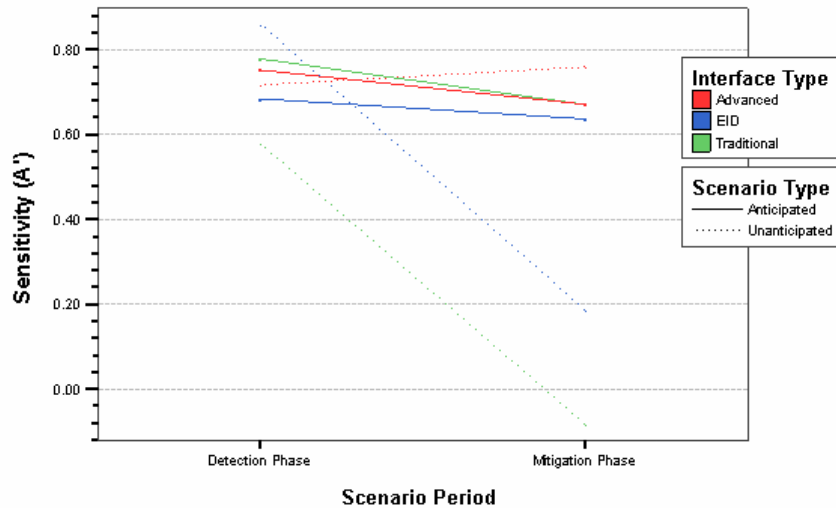

Figure 34: Mean SACRI Sensitivity (A') Scores

All answers were classified into one of four SDT categories by comparing to the actual parameter deviation as recorded by the process expert at the time of the break, i.e. not through similar log comparisons. Once the number of hits, misses, false alarms, and correct rejections were tallied, sensitivity and response bias were calculated. A summary of the scores is provided in Tables 14 and 15. The mean scores are plotted in Figures 34 and 35. An analysis was carried out to determine the main effects or interactions of interface type (A), scenario type (B), and scenario period (C). The results of a 3-way repeated measures ANOVA with Greenhouse-Geisser corrections where appropriate are shown in Table 14 for sensitivity and Table 15 for response bias. Residual plots of the

data show that the assumptions of constant variance among groups and normality in each combination hold.

Greater accuracy in detecting deviations in the process is indicated by higher A' scores; a score of $A' = 1$ is representative of perfect SA, while a score of $A' < 0.5$ is suggestive of poor SA resulting in decisions made no better than by chance. In applying the current SACRI measure, there is a possibility of undefined A' scores if the number of hits or correct rejections is zero. Although Hogg et al. (1995) have stated that undefined and negative scores will be limited in practice, no consistent guidelines were provided on how such scores are to be dealt with and interpreted. The current experiment produced a total of 13 undefined A' scores out of 72 trials or 816 queries. In a separate analysis (Skraaning Jr., 2006), it was determined that the removal of undefined data points could not be accommodated due to already limited experimental design. Treating false alarms as misses in the undefined conditions exacerbated the number of A' scores that cannot be interpreted. The transformation of accuracy based on number of correct answers to A' is considered to be valid when both are highly correlated (R close to 1), i.e. when all answers are classified as correct or incorrect, the resulting score of accuracy should be correlated with the transformed score of A' . Substituting the undefined A' scores with the lowest possible score of 0 resulted in a reduced correlation with the proportion correct, $R = 0.68$. Substituting the undefined A' score with the chance level score of 0.5 resulted in a better correlation with the proportion correct, $R = 0.82$. Accordingly, the latter modification was applied to the data. Further discussion on the theoretical shortcomings of SACRI is beyond the scope of this thesis.

Table 15: SACRI Response Bias (R:S) Summary

	Interface Type			Scenario Type		Scenario Period	
	a_1	a_2	a_3	b_1	b_2	c_1	c_2
Mean	0.9431	0.9954	0.7740	0.7753	1.0330	0.7741	1.0342
Standard Deviation	0.8308	0.5294	0.5522	0.3976	0.8150	0.6055	0.6746
Maximum	4.00	2.50	2.00	1.50	4.00	2.00	4.00
Minimum	0.00	0.22	0.00	0.00	0.00	0.00	0.00

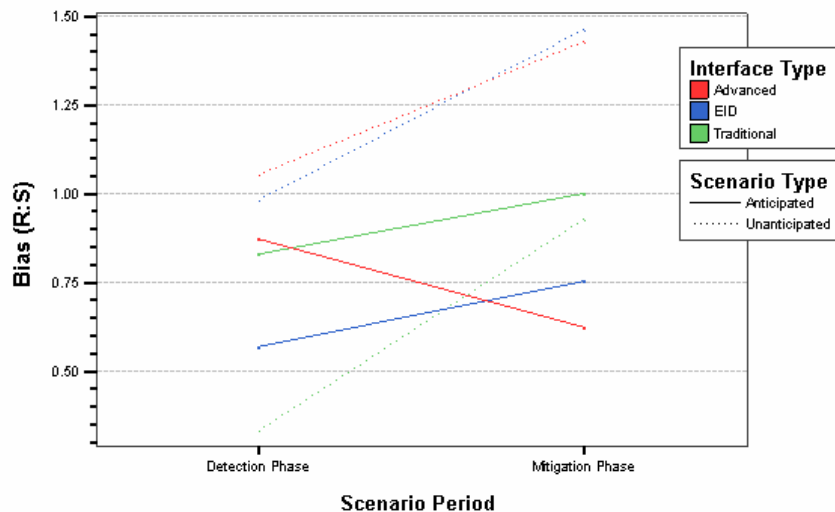

Figure 35: Mean SACRI Response Bias (R:S) Scores

The mean A' scores for the Advanced User Centred Design (UCD) and Ecological Interface Design (EID) information displays were found to be above 0.5. The Traditional Single Sensor-Single Indicator (SS-SI) yielded a mean A' score of just under 0.5. However, no main effects or interactions were observed for interface type (A), $p > 0.10$ for all conditions. Operator SA is neither improved nor degraded for the Advanced UCD and EID information displays in comparison to the Traditional SS-SI information displays. There is weak evidence of a difference in A' scores between anticipated and unanticipated scenarios [$F(1, 5) = 4.306, p = 0.093$]. A higher mean A' score was achieved by operators in the anticipated scenarios. A strong to moderate main effect was found for scenario period (C) in which operators achieved significantly higher A' scores during the detection phase vs. the mitigation phase [$F(1, 5) = 12.36, p = 0.017$]. The differences found in the two independent variables cannot, however, be explained without factoring in one another. A moderate interaction effect between scenario type (B) and scenario period (C) was observed [$F(1, 50) = 8.717, p = 0.032$] and can be seen in Figure 36 as a slope difference between the two lines. A simple effects post-hoc analysis on the two independent variables revealed that operators scored significantly lower in unanticipated scenarios during the mitigation phases of the scenarios [$F(1, 5) = 6.923, p = 0.046$]. Likewise, there is a weak to moderately significant drop in A' scores for

unanticipated scenarios going from the detection phase to the mitigation phase [$F(1, 5) = 5.870, p = 0.060$].

Table 16: SACRI Sensitivity (A') ANOVA

Effect	SS	df	Mean Square	F	p
Interface Type (A)	0.689	1.101	0.626	2.165	0.198
Scenario Type (B)	0.692	1	0.692	4.306	0.093
Scenario Period (C)	1.174	1	1.174	12.36	0.017
AxB	0.792	1.521	0.520	2.559	0.146
AxC	0.503	1.159	0.434	0.721	0.450
BxC	0.561	1	0.561	8.717	0.032
AxBxC	0.541	1.281	0.402	1.745	0.239

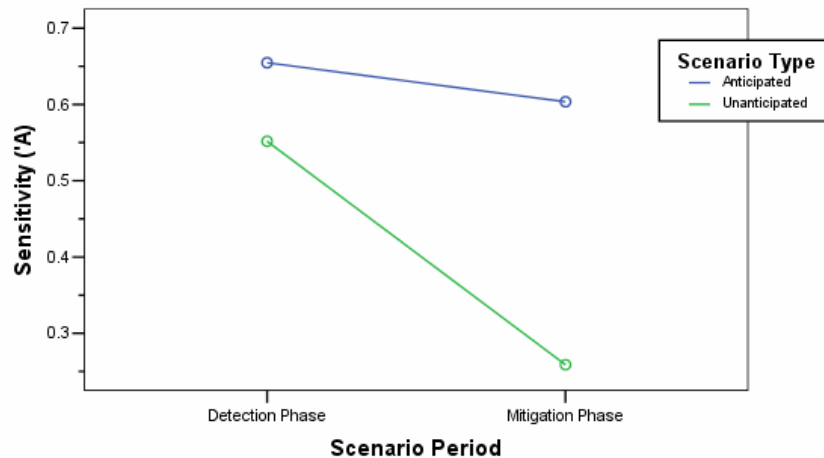

Figure 36: Scenario Type and Scenario Period A' Interaction Effect

R:S ratios were examined to provide further insight into the sensitivity results. The response bias measure describes the likelihood of an operator to overestimate or underestimate the consequences of a particular deviation depending on different factors, i.e. independent variables. A R:S ratio of 1.0 indicates no response bias, above 1.0 indicates overestimation, and below 1.0 indicates underestimation. Figure 35 suggests that operators are more likely to overestimate unanticipated events and underestimate anticipated events. In spite of this, the results of the ANOVA show no evidence of R:S ratio differences for interface type (A) and scenario type (B). There exists, however, a moderate interaction between the two variables as shown in Figure 35 [$F(1.979, 9.895) = 4.672, p = 0.038$]. A post-hoc simple effects analysis revealed differences in R:S ratios

between the three interface types in unanticipated scenarios [$F(1.927, 9.633) = 4.161, p = 0.051$]. Accordingly, a pair-wise comparison using the least significant difference approach was conducted on the R:S estimated marginal means. R:S ratios for both the Advanced UCD and EID information displays were found to be significantly different from the Traditional SS-SI information displays, $p \leq 0.05$. Operators using the Advanced UCD and EID information displays were inclined to overestimate deviations compared to the Traditional SS-SI information displays from which users underestimated. Furthermore, only the Advanced UCD information displays resulted in a difference in R:S ratios between anticipated and unanticipated scenarios [$F(1, 5) = 16.574, p = 0.01$]; greater overestimations were observed in unanticipated scenarios.

Although no evidence was found to indicate response bias differences for interface type (A) and scenario type (B) factors, the results indicate a moderate main effect for scenario period (C) [$F(1, 5) = 4.672, p = 0.038$]. Additionally, a weak interaction effect was observed between scenario type (B) and scenario period (C) [$F(1, 5) = 5.031, p = 0.075$], see Figure 38. A post-hoc simple effects analysis suggests a difference scenario type R:S ratios during the mitigation phase [$F(1, 5) = 7.307, p = 0.043$] in which there is a tendency for operators to overestimate in unanticipated scenarios and underestimate in anticipated scenarios. Likewise, there is a significant increase in the R:S ratio as the scenario proceeds from the detection phase to the mitigation phase for unanticipated scenarios [$F(1, 5) = 8.043, p = 0.036$]. No other interaction effects were found in the analysis. A complete discussion and interpretation of self-rated bias, HOPE, and SACRI results as they related to the hypotheses can be found in the following chapter.

Table 17: SACRI Response Bias (R:S) ANOVA

Effect	SS	df	Mean Square	F	p
Interface Type (A)	0.643	1.696	0.379	1.903	0.208
Scenario Type (B)	1.196	1	1.196	3.103	0.138
Scenario Period (C)	1.218	1	1.218	7.892	0.038
AxB	2.657	1.979	1.342	4.672	0.038
AxC	0.358	1.482	0.241	0.380	0.637
BxC	0.907	1	0.907	5.031	0.075
AxBxC	0.081	1.230	0.066	0.074	0.842

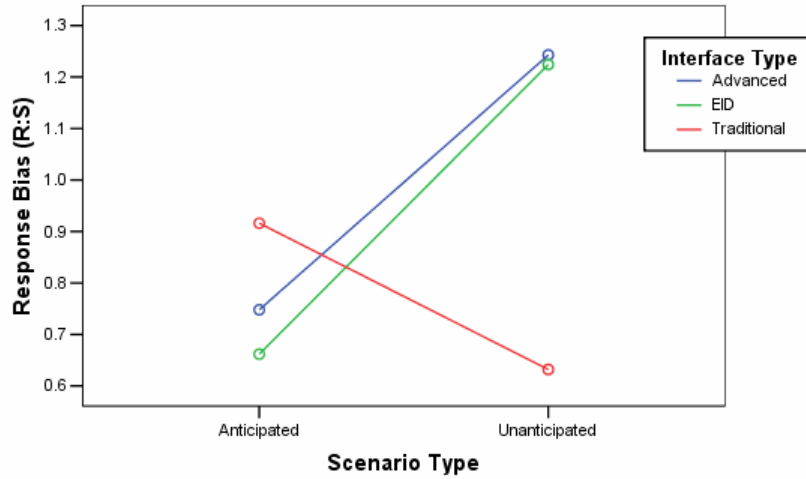

Figure 37: Interface Type and Scenario Type R:S Interaction Effect

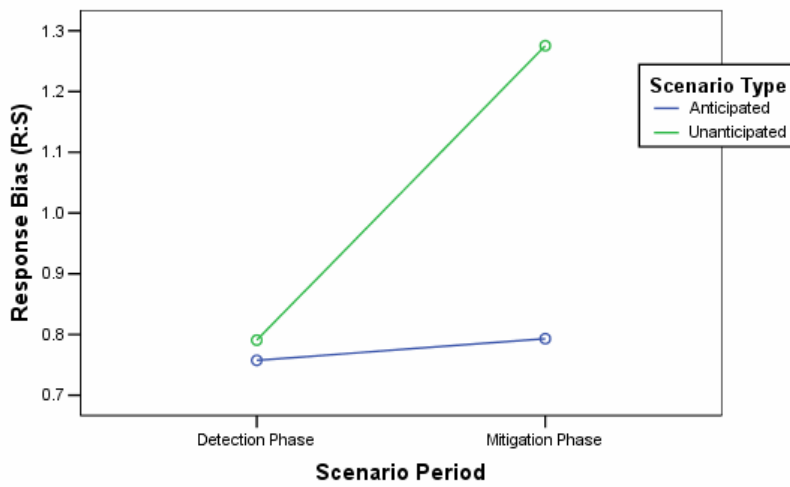

Figure 38: Scenario Type and Scenario Period R:S Interaction Effect

Chapter 6

Discussion

This chapter discusses the results of the data analysis presented in Chapter 5, its implications, and limitations. The directional and non-direction hypotheses stated in Chapter 4 are addressed. Situation awareness (SA) scores were measured using the self-rating bias, Halden Open Probe Elicitation (HOPE), and Situation Awareness Control Room Inventory (SACRI) approaches to provide better insight into actual operator SA. The preliminary results suggest that operator SA is not affected by differences in interface design alone. Other factors, namely scenario type and period, were found to have a greater effect on operator SA. A variety of potentially confounding issues and limitations may have contributed to the lack of sizable differences in the scores as hypothesized. Limiting factors in the experimental design including participant selection, training, and scenario design are examined. Technical complications encountered during the experiment are also identified and investigated for possible effects on the results.

6.1 Hypotheses Verification

Both directional and non-directional hypotheses were made for two of the main independent variables given evidence from prior research: interface type and scenario type. Although no speculations were made for the scenario period independent variable, the results will be discussed below. Note that unlike the SAGAT approach to measuring SA, the queries generated for the three dependent measures in no way incorporated the SA levels defined by Endsley (1995). In essence, the self-rated bias, HOPE, and SACRI measures are intended to describe overall SA, which includes all three levels. For example, the SACRI sensitivity score generally provides a measure of accuracy on the

detection and comprehension of elements in the environment, i.e. Level 1 and 2 SA, whereas the SACRI response bias score provides a measure of quality of operator projections and strategy selection, i.e. Level 3 SA. Accordingly, the SA scores were not parsed or examined by level.

6.1.1 Main Effect: Interface Type

It is hypothesized that a significant difference exists between the mean SA scores (m) of the turbine operators for the different interface types. In particular, the mean SA scores for the Ecological Interface Design (a_1) interface type will be significantly greater than the mean SA scores for the Advanced User Centred Design (a_2) and Traditional Single Sensor-Single Indicator (a_3) interface types.

$$H_0: m_{a1} = m_{a2} = m_{a3}$$

$$H_1: m_i \neq m_j \text{ for some } i \text{ and } j \text{ (non-directional)}$$

$$H_1: m_{a1} > m_{a2} > m_{a3} \text{ (directional)}$$

The evidence acquired from the experiment and data analysis was not sufficient to reject the null hypothesis (H_0). The mean SA scores between operators using the Ecological Interface Design (EID), Advanced User Centred Design (UCD), and Traditional Single Sensor-Single Indicator (SS-SI) information displays did not differ significantly from one another. The operators scored similarly on the self-rating bias measure with averages indicative of overall moderate SA; mean scores were found to be slightly above 3 on a scale of 1 to 5, where 1 is poor SA and 5 is perfect SA. Likewise, the operators scored approximately the same on the HOPE Level of Understanding (LoU) measure; however, mean scores fell between 1 (some understanding) and 2 (good understanding) on a scale of 0 to 3. As such, it can be reasoned that the operators are detecting some/most of the process deviations, reaching partly/mostly correct diagnoses, and carrying them out partly/mostly correct (see Appendix G). The mean SACRI sensitivity scores of the three interface types ranged approximately from 0.49 to 0.72 on a scale of 0 to 1, where 1 is representative of perfect SA; the scores did not differ significantly from one another and

suggested moderate to good operator SA. Additionally, the mean SACRI response bias scores indicate minor underestimation of deviating processes as the scores for each interface type were found to be slightly below 1.

In conclusion, the EID information displays did not improve or degrade operator SA in comparison to the Advanced UCD and Traditional SS-SI information displays in all scenario types and periods. The findings suggest that the expected benefits of the EID approach can be similarly achieved by the other two design methodologies when factors such as anticipated and unanticipated events are not differentiated. However, the effects of scenario type and period on operator SA for each interface type may be considerable. See Section 6.1.3 for a discussion on the interaction effects. Resource constraints, including limited training and lack of participants, may have, however, confounded the results. The expected outcome inferred from prior EID and SA research was not obtained. See Section 6.3 for details.

6.1.2 Main Effect: Scenario Type

It is hypothesized that a significant difference exists between the mean SA scores (m) of the turbine operators for the difference scenario types. In particular, the mean SA scores for anticipated scenarios (b_1) will be significantly greater than the mean SA scores for unanticipated scenarios (b_2).

$$H_0: m_{b1} = m_{b2}$$

$$H_1: m_{b1} \neq m_{b2} \text{ (non-directional)}$$

$$H_1: m_{b1} > m_{b2} \text{ (directional)}$$

The evidence acquired from the experiment and data analysis was not sufficient to reject the null hypothesis (H_0). The mean SA scores between anticipated and unanticipated scenarios did not differ significantly from one another. The mean self-rated bias scores were essentially the same for both scenario types; approximately 3.2 on a scale of 1 to 5, where 5 is representative of perfect SA. As well, no difference in HOPE LoU scores were found; both scenario types yielded scores of approximately 1.3 on a scale of 0 to 3, where

3 denotes full understanding of a situation (see Appendix G). While anticipated scenarios yielded slightly higher SACRI sensitivity scores, the evidence is weak and inconclusive: mean sensitivity scores of 0.70 in anticipated scenarios vs. 0.50 in unanticipated scenarios on a scale of 0 to 1, where 1 is representative of perfect SA. No significant differences were found in SACRI response bias scores, which indicates little to no underestimation of process deviations in both anticipated and unanticipated scenarios.

It can be concluded that operator SA remains relatively constant when unanticipated situations arise for all interface types and scenario periods, i.e. no improvement or degradation in comparison to anticipated events. Though generally thought to decrease the amount of cognitive resources available for achieving higher levels of SA, the unanticipated scenarios presented in the experiment did not yield the expected results. It is known that interfaces and training programs cannot be designed to support specific unanticipated events, i.e. events are not known ahead of time and cannot be incorporated into the design. As such, it is expected that the interface types will have an effect on operator SA depending on the type of event encountered. See Section 6.1.3 for a discussion on the interaction effects. Again, resource constraints and limitations with scenario design may have contributed to the lack of differences. In particular, it was observed that the outcome of several anticipated scenarios would have differed had there been a shift supervisor on the crew to coordinate standardized responses to known process deviations. See Section 6.3 for more details.

6.1.3 Interaction Effect: Interface Type and Scenario Type

It is hypothesized that a significant difference exists between the mean SA scores (m) of the turbine operators for some treatment combination of interface type and scenario type. No difference in the mean SA scores is expected between the interfaces for anticipated scenarios (b_1). Given that each design approach handles unanticipated scenarios (b_2) in a unique manner, a significant difference in the mean SA scores between the interfaces is expected. In particular, the mean SA scores for the EID information displays will be greater than or equal to the mean SA scores for the Advanced UCD information displays,

while the mean SA scores for the Traditional SS-SI information displays will be significantly lower.

$$H_0: m_{ij} - m_{i'j} - m_{ij'} - m_{i'j'} = 0 \text{ for all treatment combinations}$$

$$H_1: m_{ij} - m_{i'j} - m_{ij'} - m_{i'j'} \neq 0 \text{ (non-directional)}$$

$$H_1: m_{a1b1} = m_{a2b1} = m_{a3b1} > m_{a1b2} \geq m_{a2b2} \geq m_{a3b2} \text{ (directional)}$$

The evidence acquired from the experiment and data analysis was largely not sufficient to reject the null hypothesis (H_0), i.e. majority of the dependent measures did not result in significance. Under all interface type and scenario type treatment combinations, the operators scored similarly on self-rated bias and HOPE LoU; the three information displays yielded moderate to good operator SA under both anticipated and unanticipated scenarios. Although no interaction effect was found in the SACRI sensitivity scores, the SACRI response bias scores show that operators using EID and Advanced UCD information displays have a tendency to overestimate unanticipated process deviations in comparison to the Traditional SS-SI information displays. The SACRI results suggest that operators achieved less than ideal SA during unfamiliar events due to poor projection of deviating elements. However, the SACRI response bias differences alone do not provide adequate evidence to show that operators achieve better SA using certain interfaces under specific scenario types.

While the EID and Advanced UCD information displays did not improve overall operator SA over Traditional SS-SI information displays in unanticipated scenarios, operator ability to achieve ideal SA is affected. When examined alone, the EID and Advanced UCD information displays resulted in riskier projections and strategy selections, whereas the Traditional SS-SI information display motivated conservative decision making. It is possible that visual elements such as emergent features and historical trend plots in the non-traditional displays lead to looser projections. However, a more likely explanation is that training was limited, particularly in the use of advanced graphical features, some of which require more experience than time allowed. For example, the individual graphics in the EID information display such as the mass balances are intended to support skill-based behaviour including the perception of

process deviations. The graphics are organized in a manner to support knowledge-based behaviour that develops primarily over time through experience. The effect was perhaps not seen in the Traditional SS-SI information display due to similarities with the existing control room interfaces, which are generally approached in a conservative manner.

It was hypothesized that unanticipated events could be supported through the visualisation of work environment constraints. Prior research has shown that the detection of out-of-bounds conditions, which are not typically apparent in non-EID information displays, allows for better diagnosis of new and unfamiliar situations. The self-rated, HOPE LoU, and SACRI sensitivity scores acquired from the experiment did not confirm the hypothesis. As mentioned previously, the condensed training program is likely to have contributed to ineffective use of the advanced graphical features in the interfaces, i.e. not used to full potential. See Section 6.3 for more details on the possible limitations of the study. However, it can be concluded that operator SA is not degraded through the use of EID information displays despite minimal training, i.e. no worse than operator SA achieved in Traditional SS-SI information displays.

6.1.4 Main Effect: Scenario Period

For exploratory purposes, the data acquired in the experiment was examined for a main effect of scenario period. The data analysis on HOPE LoU and SACRI sensitivity scores revealed significant differences in operator SA while progressing from detection to mitigation phase in a scenario. No evidence of changes in mean SA scores was found from the self-rated bias measure. A quadratic trend was observed over time for the HOPE measure where the LoU scores increase going into the mitigation phase and slowly decrease towards the end of the scenario. The effect is not unexpected given that an operator's understanding of a situation increases as more information is acquired over time. A subsequent drop in HOPE LoU scores was nonetheless encountered during the mitigation phase. It is suspected that as the mitigation phase progresses, the operators are faced with an increasing number of events and information thus reducing the amount of cognitive resources available even further; operators are likely attempting to problem solve and detect new deviations at the same time. The effect is more clearly illustrated in

the SACRI sensitivity scores where a significant drop occurs in the mitigation phase. Operators averaged 0.74 during the detection phase and 0.47 at the end of the mitigation phase on a scale of 0 to 1, where 1 is representative of perfect SA. As well, operators were more likely to underestimate deviations in the detection phase vs. the mitigation phase. An overall increase was observed in the HOPE LoU scores despite the quadratic trend. The lack of a consistent effect indicates a possible limitation in the experiment and measurement.

Similar to the hypothesized interaction effects between interface type and scenario type, it can be expected that EID information displays improve operator SA in both the detection and mitigation phases. Specific visual elements such as blue diamond set points in the valve-positioning graphic are intended to provide operators with a skill-based mechanism to detect deviations, i.e. changes are readily perceived. The embedded abstraction hierarchy of the turbine systems aims to aid operator development of accurate mental models for problem solving. The Advanced UCD information displays attempt to improve change detection over time primarily through trend graphics, but theoretically lack components required to support knowledge-based behaviour. Accordingly, differences in operator SA are expected between the three interface types and scenario periods. However, contrary to the above assumptions, no evidence was found to indicate that such differences existed. Again, it is suspected that the results are constrained by the experimental design and measurement approaches, though it is likely that the features in the different interfaces affect the detection and mitigation phases equally, i.e. no interaction effect. See Section 6.3 for more details.

6.2 Contributions to Ecological Interface Design and Situation Awareness

As summarized in Chapter 1, this thesis aims to make several contributions to existing EID and SA literature. The development of EID information displays for the turbine secondary systems of the Forsmark 3 boiling water reactor power plant is thoroughly described in Chapter 3. The design process outlined in Burns and Hajdukiewicz (2004) was effectively adapted to the larger-scale system of interest in this study. A modularised

approach to the system analysis was made possible by careful division of the subsystems. All interactions such as material exchange between the subsystems were noted as such to prevent loss of information when the products, i.e. Work Domain Models, of each module were merged. The EID framework is shown in this study to be adequately flexible for large-scale complex systems consisting of subsystems; analysis and design can be carried out separately and in parallel to maximize resources.

The experimental design and evaluation of EID information displays in a next-generation simulated control room (HAMMLAB) with trained nuclear power plant operating crews is covered in Chapter 4. The experiment was carried out fully and successfully aside from some minor technical problems in the simulator. The current EID study is among one of the few conducted in a full-scope environment involving licensed operators. Given that the benefits of EID have been replicated in small laboratory studies, the data collected in this experiment provides results that are of higher ecological validity and representative of effects in actual control room environments. Recall that this thesis in particular examines the effects of EID on SA and not on performance, which prior research has focused on. At the same time, it is possible to confound the results by employing operators already familiar with the control condition, in this case the Traditional SS-SI information displays. Since the interfaces are currently still under evaluation, i.e. not implemented in the live Forsmark 3 control room, it is hoped that any past experience with HAMMLAB and the Traditional SS-SI information displays is negated through training. A little over half of the operators participated in past HAMMLAB studies.

Although insufficient evidence was found in the data analysis to suggest that the EID approach offered superior support for operator SA, the results provide a basis for forthcoming studies examining the effects of EID on SA. The EID information displays yielded comparable SA scores to the other interface types; in effect, EID support for operator SA was determined to be no better or worse than that provided by existing traditional control room interfaces. Without taking the limitations of the study into account, the findings supply further evidence of the fundamental differences between performance and SA. It has been shown in previous research that an increase in operator performance does not necessarily result in an increase SA (Endsley, Bolté, & Jones,

2003). The EID approach is expected to improve operator performance over the other existing design approaches as established in prior EID research (Vicente, 1999a). Nonetheless, it cannot be concluded that an equivalent increase in SA occurs along with an increase in performance. Limitations namely involving training and participant sampling appear to be contributing factors to the lack of differences in operator SA. It is possible that proper rule-based corrective actions were carried out as a result of experience in spite of minimal interface training, which is suspected to have led to non-ideal SA. Note that performance data collected via the Operator Performance Assessment System (OPAS) measure is currently being examined in a separate study.

Overall, operators developed moderate to good SA under all interface and scenario conditions; mean SA scores fell halfway between the points indicating poor SA and perfect SA. The resulting self-rated bias, HOPE LoU, and SACRI scores serve as absolute benchmarks for follow-up experiments utilising similar measures. Without an analysis to classify SA scores by level, it is not possible to determine precisely at which level improvement is needed. Because Level 3 SA is theorized to require Levels 1 and 2 SA, i.e. an operator cannot form accurate projections without the first two levels, it can be inferred that operators in the present study did not successfully achieve Level 3 SA. Though the EID information displays were expected to improve Levels 1 and 2 SA, the results obtained suggest potential effects from training and experience. Usability data collected during the experiment may be used to enhance certain elements in the interfaces, but improvements to operator SA appear to require changes beyond the interfaces themselves.

6.3 Limitations

A number of limitations related to the experimental design and the technical aspects of the simulating environment were identified in the study (no particular order):

- Participant experience: A wide range of experienced control room operators were recruited from the Forsmark 3 boiling water reactor nuclear power plant for the experiment. The demographic details of the participants are summarized in Table 9.

Though unlikely to have significantly influenced the SA results, it should be noted that some of the current reactor operators (RO) and shift supervisors (SS), i.e. former turbine operators (TO), were asked to perform the tasks of a TO. Because the present study focuses on the turbine systems to the plant, a greater number of present TO participants would have been preferable. Participation was open to all control room operators, no experience restrictions.

- Crew composition: As noted previously, a typical control room crew consists of one TO, one RO, and one SS. Due to the limited number of participants, the SS role was excluded from the study. Furthermore, the study focuses on the effects of different interfaces on TO SA alone as team SA is beyond the scope of this thesis. However, it was observed that the lack of a SS was detrimental to TO SA on several occasions, in which certain cross-system information such as that from the reactor side would have been relayed to the TO. The results are representative of SA acquired and developed through mainly the turbine side interfaces.
- Training: The lack of significant differences in operator SA between interfaces and scenario types is largely attributed to the limitations in training. Prior to the trials, the participants were familiarized with the HAMMLAB environment and trained to use the various interfaces. In total, the operators were given 7 hours of instruction. Although slightly more time was devoted to the EID information displays, it was not possible for participants to fully grasp and understand certain graphical elements designed for longer term use, e.g. patterns produced by trend graphs, balance displays. In addition, participants were provided with reference sheets as memory aids because of the overwhelming number of features found in each interface and in particular the EID information displays. Many of the visual elements intended to improve Levels 2 and 3 SA, e.g. mass balance bar connections to mimic graphics, were perhaps used less effectively than anticipated due to limited experience with the interface. Given that some of the participants had prior experience with the Traditional SS-SI and Advanced UCD information displays, as well as possible positive learning transfer from the existing control room interface, novice EID users

can be said to develop SA on par with slightly more experienced Traditional SS-SI and Advanced UCD users.

- SA measures: To provide a more extensive view of operator SA, three types of SA measures with a variety of different advantages and disadvantages were employed in the study; self-rated bias (subjective self), HOPE (subjective third-party), and SACRI (objective). A few assumptions are required to be made in order for the data collected from the above measures to adequately reflect operator SA. It is assumed that all the measures are sufficiently sensitive to differences in operator expertise, changes in process state, and changes to the interface. However, the self-rated bias and HOPE measures have not been previously tested to verify the assumptions. It is possible that the measures do not accurately quantify operator SA. Even with verification of the aforementioned assumptions, the underlying fundamentals of the SACRI measure were brought into question (Skraaning Jr., 2006). Again, an analysis of measurement limitations is beyond the scope of this thesis, but the issue should be considered.
- Data analysis and interpretation: Not considered a limitation, but a topic related to the above points on SA measures; varying results were obtained in a separate preliminary analysis (Skraaning Jr., Lau, Welch, Nihlwing, Andresen, Brevig, Veland, Jamieson, Burns, & Kwok, 2007; Welch, Braseth, Nihlwing, Skraaning Jr., Teigen, Veland, Lau, Jamieson, Burns, & Kwok, 2007) as a result of differences in the statistical approach and theoretical interpretation. Due to the SACRI measure limitations, a simple accuracy score was calculated with the collected query response data. A three-way interaction effect was found between the three variables for both accuracy and HOPE (scenario understanding) scores through a multivariate approach. The present study forgoes the use of a multivariate analysis due to small sample sizes. Additionally, the self-rated bias (metacognitive accuracy) scores included all queries, i.e. not specifically measuring SA. However, only a main effect of scenario type was revealed. The differences in the results provide an indication of how sensitive the data collected is due to the limitations explained in this section. While the present study does not separate SA by levels as described in Endsley (1995), an attempt was made

in the Appendix J analysis by interpreting the levels through the queries themselves rather than the related variables or information. In particular, it can be said that global variables in SACRI queries require lower level information found in Level 1 SA and as such are associated with Level 2 or higher SA. An alternate interpretation as assumed in Appendix J is that all queries probe perception, which in effect is Level 1 SA. An in-depth analysis of SA theory and measurement is beyond the scope of this thesis.

- Scenario design: The complexity of both the anticipated and unanticipated events is likely to have affected some of the scenario type results, performance data more so than SA data. Anticipated scenarios were designed to involve situations that are intended to be resolved through standard procedures. Unanticipated scenarios included a series of events that could not be diagnosed through traditional rule-based strategies. It was observed that the sequence of events in both types of scenarios was at times rendered more complex than expected due to operator interaction with the system. Actions performed by the operators resulted in new events affecting the development of the scenario and thus the corrective actions required for a resolution, e.g. an anticipated scenario becoming more difficult to handle through standard procedures. In general, the SA measurements are made in a manner relative to the present situation thus the effects are expected to be minimal.

- Simulator: Certain elements in the EID information displays were re-designed as a result of technical limitations in the simulator and interface design platform (Picasso). In particular, the polar star graphics representing valve positioning were replaced due to implementation difficulties involving the scaling of the graphics. As well, the lack of mass sensors in the turbine subsystems required that the values be calculated in the simulator, which were not always accurate due to sampling constraints. Some variables traditionally not included in control room interfaces were deemed essential in EID information displays, but could not be fully implemented. A few unexpected technical problems in the simulator were also encountered during the experiment, one

of which required a scenario restart. Any learning effects from the incident is not expected to have altered the results significantly as only one trial was affected.

The above list of limitations has influenced the data collected in the present study to varying degrees and should be taken into account when interpreting the results.

Additionally, a follow-up study addressing some of the issues may help in confirming or refuting the current results.

Chapter 7

Summary and Recommendations

This study demonstrates the effects of Ecological Interface Design (EID) information displays on operator situation awareness (SA) relative to existing human-machine interfaces (HMI) in control rooms. The preliminary results suggest that operators unfamiliar with EID information displays develop and maintain comparable levels of SA to operators using traditional forms of single sensor-single indicator (SS-SI) information displays. Operator SA remained relatively constant between anticipated and unanticipated scenarios, as well as throughout each scenario, from the detection phase to the mitigation phase. In all cases, operators achieved moderate to good SA, i.e. approximately halfway to perfect SA. With sufficient training and experience, operator SA is expected to benefit from the knowledge-based visual elements in the EID information displays. The following are recommendations for expanding the present study:

- Obtaining a sufficient number of licensed participants to field a complete control room operating crew consisting of one turbine operator (TO), one reactor operator (RO), and one shift supervisor (SS). Allows for better ecological validity and the option of examining team SA.
- Extending the training program in length as well as content to include practice scenario sessions that cover all visual elements in each interface. In essence, implementing a hands-on approach for practice to support the existing instructional elements of the training program.
- Until some of the fundamental issues with the Situation Awareness Control Room Inventory (SACRI) measure are resolved, it is advisable that the study utilises a more

established measure such as Situation Awareness Global Assessment Technique (SAGAT).

- Confirming that the EID information displays improve operator performance, i.e. examining the Operator Performance Assessment System (OPAS). Subsequently, investigating whether a correlation exists between operator performance and SA.

Although the results do not illustrate a significant immediate improvement to operator SA in the EID framework, the longer-term effects appear to be promising and should be explored in a follow-up study. Nonetheless, the overall findings establish the viability of the EID approach in large-scale complex process control systems and in next-generation control rooms.

References

Burns, C. M. (2000). Putting it all together: Improving display integration in ecological displays, *Human Factors*, 42, 226-241.

Burns, C. M., & Hajdukiewicz, J. R. (2004). *Ecological Interface Design*. Boca Raton, FL: CRC Press.

Canadian Nuclear Safety Commission. (2003). Volume 3: Electrical. In, Science & Reactor Fundamentals Training Course (CANTEACH Doc. # 20030801). Toronto, ON: CANTEACH Project.

Çengel, Y. A. (1997). *Introduction to Thermodynamics and Heat Transfer*. New York, NY: McGraw-Hill College.

Cohen, J. (1992). Quantitative methods in psychology: A power primer. *Psychological Bulletin*, 112 (1), 155-159.

Dinadis, N., & Vicente, K. J. (1996). Ecological interface design for a power plant feedwater subsystem. *IEEE Transactions on Nuclear Science*, 43, 266-277.

Dinadis, N., & Vicente, K. J. (1999). Designing functional visualizations for aircraft systems status displays. *International Journal of Aviation Psychology*, 9(3), 241-269.

Duez, P., & Vicente, K. J. (2005). Ecological interface design and computer network management: The effects of network size and fault frequency. *International Journal of Man-Machine Studies*, 63(6), 565-586.

Endsley, M. R. (1988). Design and evaluation for situation awareness enhancement. In, *Proceedings of the Human Factors Society 32nd Annual Meeting* (pp. 97-101). Santa Monica, CA: Human Factors Society.

Endsley, M. R. (1995). Toward a theory of situation awareness in dynamic systems. *Human Factors*, 37(1), 32-64.

Endsley, M. R. (2000). Theoretical underpinnings of situation awareness: a critical review. In M. R. Endsley and D. Garland (Eds), *Situation Awareness Analysis and Measurement Mahwah* (pp. 3-32), NJ: Lawrence Erlbaum Associates Inc.

Endsley, M. R., Bolté, B., & Jones, D. G. (2003). *Designing for situation awareness: An approach to human-centered design*. London: Taylor & Francis.

Endsley, M. R., & Garland, D. J. (2000). *Situation Awareness Analysis and Measurement*. Mahwah, NJ: Lawrence Erlbaum Associates.

Flach, John M., (1995). Situation Awareness: Proceed with Caution. *Human Factors*, 37(1), 149-157.

Garabet, A., & Burns, C.M. (2004). Collaboration with Ecological Interface Design. In, *Proceedings of the 48th Annual Meeting of the Human Factors and Ergonomics Society* (pp. 543-546). Santa Monica, CA: Human Factors and Ergonomics Society.

Gibson, J. J. (1979). *The ecological approach to visual perception*. Boston, MA: Houghton Mifflin.

Hajdukiewicz, J. R., Doyle, D. J., Milgram, P., Vicente, K. J., & Burns, C. M. (1998). A structured approach for patient monitoring in the operating room. In, *Proceedings of the Human Factors and Ergonomics Society 42nd Annual Meeting* (pp. 1038-1042). Santa Monica, CA: Human Factors and Ergonomics Society.

Halliday, D., Resnick, R., & Walker, J. (1996). *Fundamentals of Physics Extended*. 5th Edition. New York, NY: John Wiley & Sons.

Hintze, J. (1994). *NCSS and PASS. Number Cruncher Statistical Systems*. Kaysville, UT, www.ncss.com.

Ho, D., & Burns, C.M. (2003). Ecological Interface Design in Aviation Domains: Work Domain Analysis of Automated Collision Detection and Avoidance. In, *Proceedings of Human Factors and Ergonomics 47th Annual Meeting* (pp. 119-123). Santa Monica, CA: Human Factors and Ergonomics Society.

Hogg, D.N, Follesø, K., Strand-Volden, F., Torralba, B. (1995). Development of a situation awareness measure to evaluate advanced alarm systems in nuclear power plant control rooms, *Ergonomics*, 38(11), 2394–2413.

Itoh, J., Sakuma, A., & Monta, K. (1995). Ecological interface for supervisory control of BWR nuclear power plants. *Control Engineering Practice*, 3, 231-239.

Jamieson, G. A. (2002). Empirical Evaluation of an Industrial Application of Ecological Interface Design. In, *Proceedings of the 46th Annual Meeting of the Human Factors and Ergonomics Society* (pp. 536-540). Santa Monica, CA: Human Factors and Ergonomics Society.

Jones, D. G., & Endsley, M. R. (1996). Sources of situation awareness errors in aviation. *Aviation, Space, and Environmental Medicine*, 67(6), 507-512.

Kemeny J. G. (1979). *Report of the president's commission on the accident at Three Mile Island*. Washington DC: US Government Printing Office.

Kuo, J., & Burns, C. M. (2000). A work domain analysis for virtual private networks. In, *IEEE International Conference on Systems, Man, and Cybernetics* (pp. 1972-1977). Nashville, TN: IEEE.

Lau, N. (2006). *HAMBO EID Colour Scheme and Boundaries*. Unpublished manuscript.

Lindsley, D. (2000). *Power-Plant Control and Instrumentation: The Control of Boilers and HRSG Systems*. London, UK: Institution of Electrical Engineers.

Nadimian, R., & Burns, C.M. (2004). A visual display of flight time and distance. In, *Proceedings of the 48th Annual Meeting of the Human Factors and Ergonomics Society* (pp. 6-10). Santa Monica, CA: Human Factors and Ergonomics Society.

Mumaw, R. J., Roth, E. M., Vicente, K. J., & Burns, C. M. (2000). There is more to monitoring a nuclear power plant than meets the eye. *Human Factors*, 42(1), 36-55.

Ontario Power Generation. (1988). Nuclear Training Course: Course 225 (CANTEACH Doc. # 20043100-20043109). Toronto, ON: CANTEACH Project.

Ontario Power Generation. (1994). Nuclear Training Course: Course 234 (CANTEACH Doc. # 20042401). Toronto, ON: CANTEACH Project.

Pawlak, W. S., & Vicente, K. J. (1996). Inducing effective operator control through ecological interface design. *International Journal of Human-Computer Studies*, 44, 653 – 688.

Pew, R.W. (1995) . The state of situation awareness measurement: Circa 1995. In D. Garland & M. R. Endsley (Eds.), *Experimental Analysis and Measurement of Situation Awareness* (pp. 7-16). Mahwah, NJ: Lawrence Erlbaum Associates.

Rasmussen, J. (1983). Skills, rules, knowledge; signals, signs, and symbols, and other distinctions in human performance models. *IEEE Transactions on Systems, Man and Cybernetics*, 13, 257-266.

Rasmussen, J. (1985). The role of hierarchical knowledge representation in decision making and system management. *IEEE Transactions on Systems, Man and Cybernetics*, 15, 234-243.

Rasmussen, J. (1990). Mental models and the control of action in complex environments. In D. Ackermann, & M. J. Tauber (Eds.), *Mental Models and Human-Computer Interaction I* (pp.41-46). North-Holland: Elsevier Science Publishers.

- Rasmussen, J., & Vicente, K. J. (1989). Coping with human errors through system design: Implications for ecological interface design. *International Journal of Man-Machine Studies*, 31, 517-534.
- Rosenthal, R., Rosnow, R. L. & Rubin, D. B. (2000). *Contrasts and effect sizes in behavioral research*. UK: Cambridge University Press.
- Roth, E. M., Randall, J. M., & Stubler, W. F. (1993). Human Factors Evaluation Issues for Advanced Control Rooms: A Research Agenda. In, *IEEE Fifth Conference on Human Factors and Power Plants* (pp. 254-260). New York: IEEE.
- Skraaning Jr., G. (2005). *Untitled photograph*. Unpublished photograph.
- Skraaning Jr., G. (2006). *Situation Awareness Control Room Inventory (SACRI) Revisited*. Unpublished manuscript.
- Skraaning Jr., G., Lau, N., Welch, R., Nihlwing, C., Andresen, G., Brevig, L. H., Veland, Ø., Jamieson, G. A., Burns, C., & Kwok, J. (2007). *The Ecological Interface Design Experiment (2005)*. Internal report (HWR-833), Halden Reactor Project.
- Skraaning Jr., G., Nihlwing, C. G., Welch, R., & Veland, Ø. (2005a). *Halden Reactor Project: Ecological Interface Design Experimental Design Proposal*. Unpublished manuscript.
- Skraaning Jr., G., Nihlwing, C. G., Welch, R., & Veland, Ø. (2005b). *Halden Open Probe Elicitation (Draft)*. Unpublished manuscript.
- St-Cyr, O. (2006). Impact of Sensor Noise Magnitude on Emergent Features of Ecological Interface Design. In, *Proceedings of the Human Factors and Ergonomics Society 50th Annual Meeting* (pp. 319-323). Santa Monica, CA: Human Factors and Ergonomics Society.
- Vicente, K. J. (1991). *Supporting knowledge-based behavior through ecological interface design*. Unpublished doctoral dissertation, Department of Mechanical and Industrial Engineering, University of Illinois at Urbana-Champaign.
- Vicente, K. J. (1999a). Ecological interface design: Supporting operator adaptation, continuous learning, & distributed, collaborative work. In Lenca, P. (Ed.), *Proceedings of HCP 99, Human Centered Processes Conference, September 22-24* (pp. 93-97). Brest, France.
- Vicente, K. J. (1999b). *Cognitive work analysis: Toward safe, productive, and healthy computer-based work*. Mahwah, NJ: Lawrence Erlbaum Associates.
- Vicente, K. J. (2002). Ecological interface design: Progress and challenges. *Human Factors*, 44, 62-78.

Vicente, K. J. & Rasmussen, J. (1990). The ecology of human-machine systems II: Mediating "direct perception" in complex work domains. *Ecological Psychology*, 2, 207-249.

Vicente, K. J., & Rasmussen, J. (1992). Ecological interface design: Theoretical foundations. *IEEE Transactions on Systems, Man and Cybernetics*, 22, 589-606.

Waag, W.L. & Houck, M. R. (1994). Tools for assessing situational awareness in an operational fighter environment. *Aviation, Space and Environmental Medicine*, 65(5), A13-A19.

Watson, M., Russell, W. J., & Sanderson, P. (2000). Anaesthesia monitoring, alarm proliferation, and ecological interface design. *Australian Journal of Information Systems*, 7(2), 109-114.

Welch, R., Braseth, A. O., Nihlwing, C., Skraaning Jr., G., Teigen, A., Veland, Ø., Lau, N., Jamieson, G., Burns, C., & Kwok, J. (2007). *The 2005 Ecological Interface Design Process and the Resulting Displays*. Internal report (HWR-847), Halden Reactor Project.

Wickens, C. D., & Hollands, J. G. (2000). *Engineering Psychology and Human Performance (3rd ed.)*. Upper Saddle River, NJ: Prentice Hall.

Appendix A

Legends

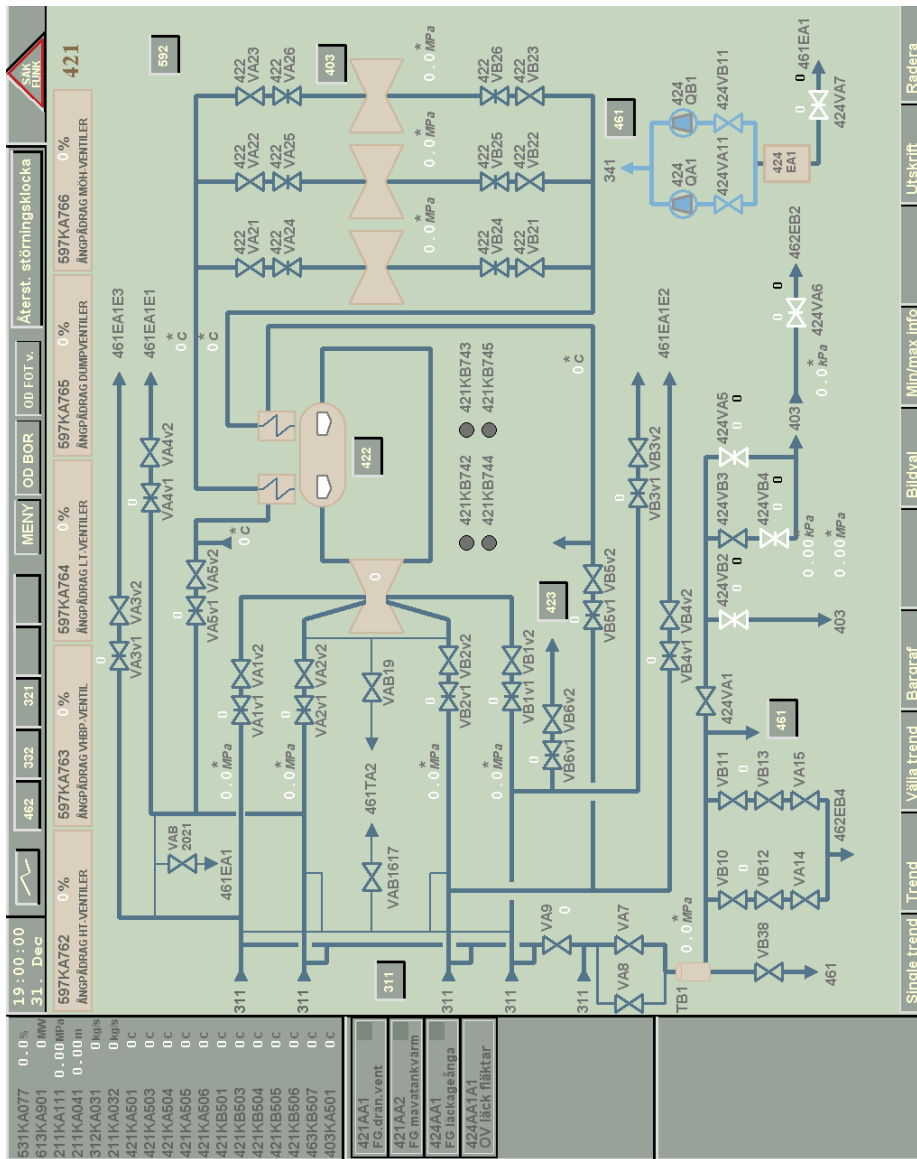

Figure 39: Mimic Display of Main Steam (421) Subsystem

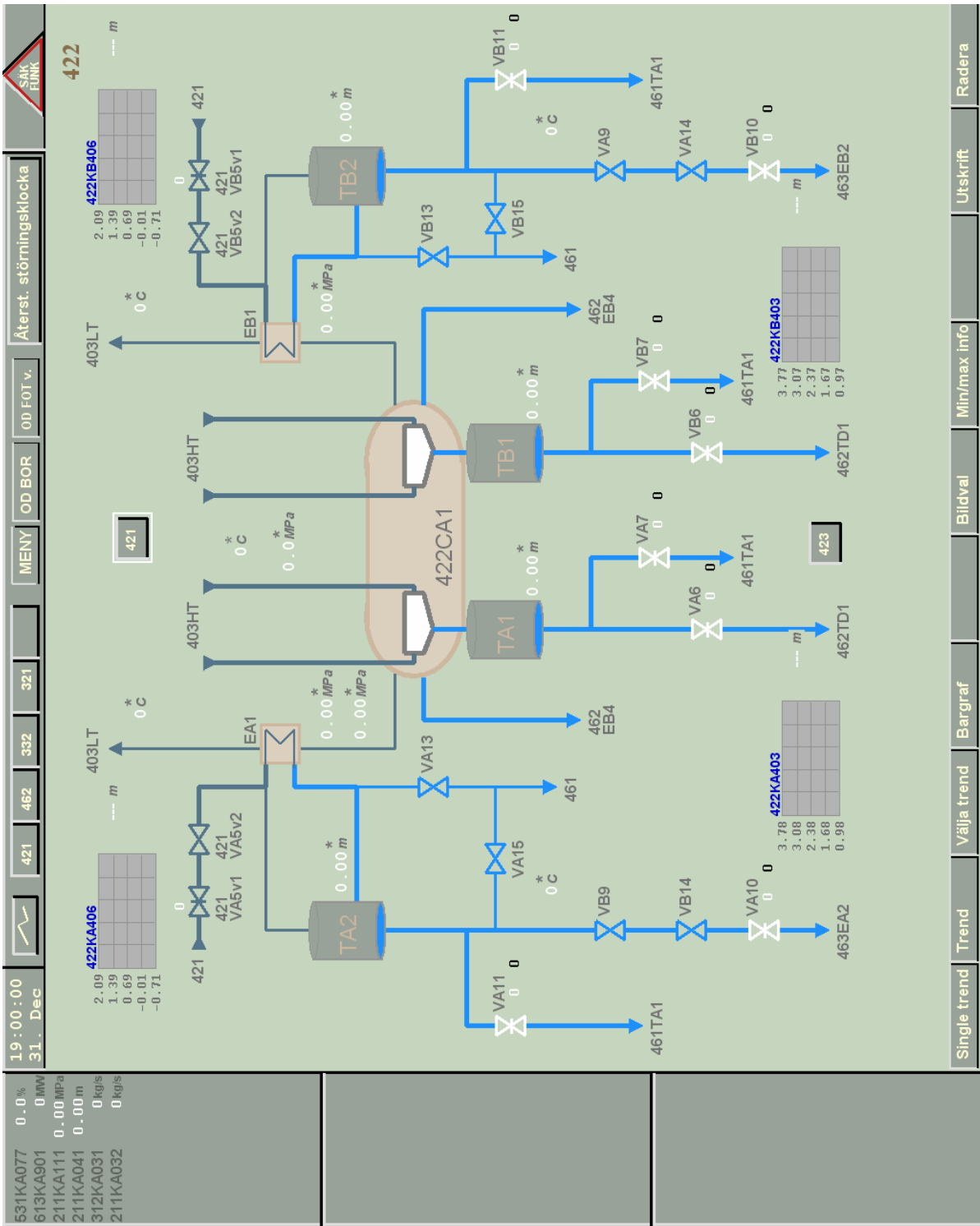

Figure 40: Mimic Display of Steam Reheat (422) Subsystem

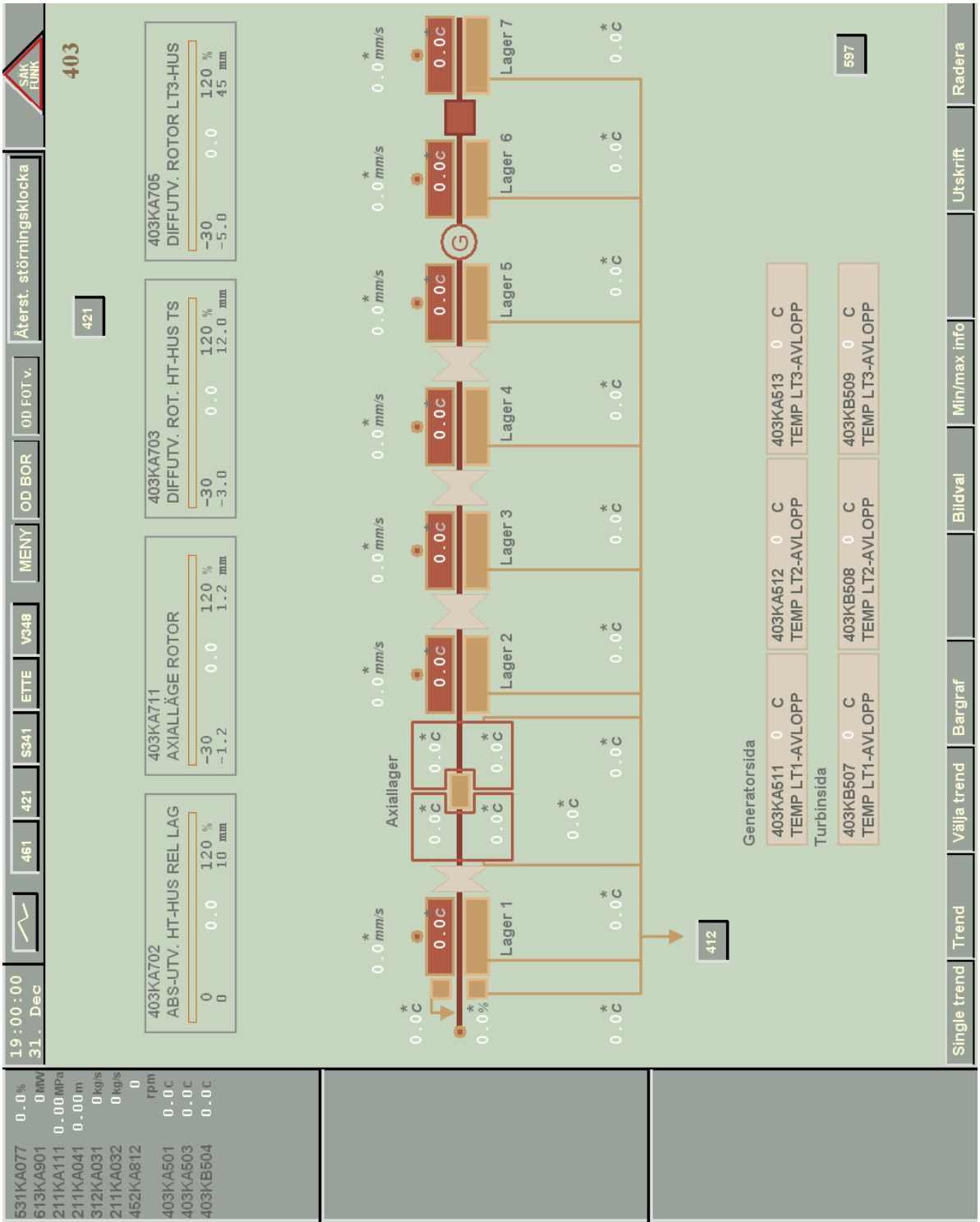

Figure 41: Mimic Display of Turbine (403) Components

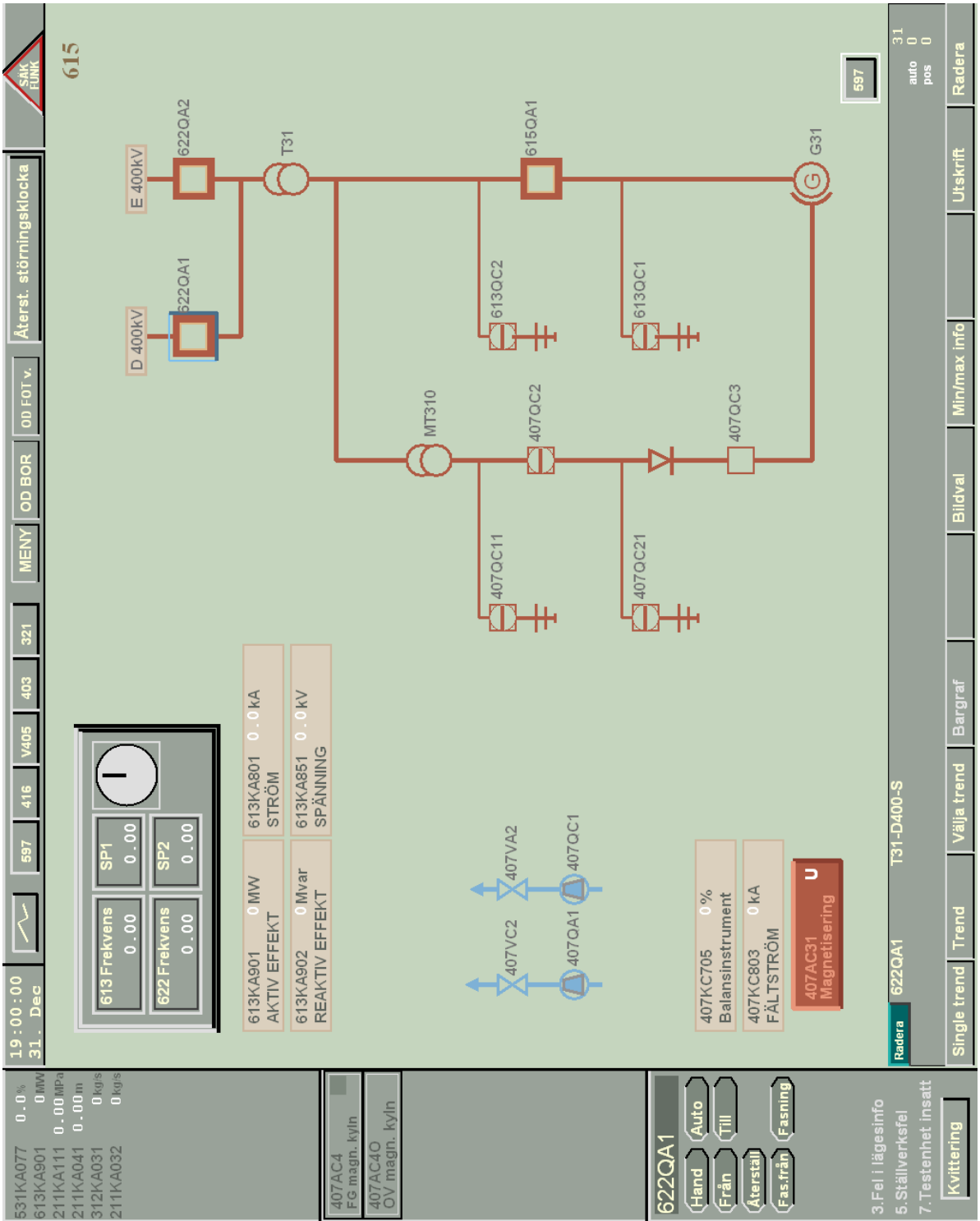

Figure 42: Mimic Display of Generator (615) Components

Appendix B

Diagram Legends

Table 18: System Number Legend

System Number	Description
211	Reactor Vessel
311	Steam Valves
403	Turbines
405	Generator
407	Magnetisation and Voltage Regulation System
412	Lubrication and Jacking Oil System
416	Seal Oil System
421	Main Steam System
422	Steam Reheat System
423	Steam Extraction System
424	Seal and Leakage Steam Leakage System
441	Main Cooling Water System
445	Generator Cooling System
452	Governing Oil System
461	Condenser and Vacuum System
462	Feedwater System

Steam		Electricity	
Exhaust Steam		Bypass	
Oil		Drain	
Condensate / Feedwater		Bleed	
Sea Water		Vacuum	
Radioactive Gases			
Non-Radioactive Gases			
Compressed Air			

Figure 43: Material Colour Legend (Adapted from Lau, 2006)

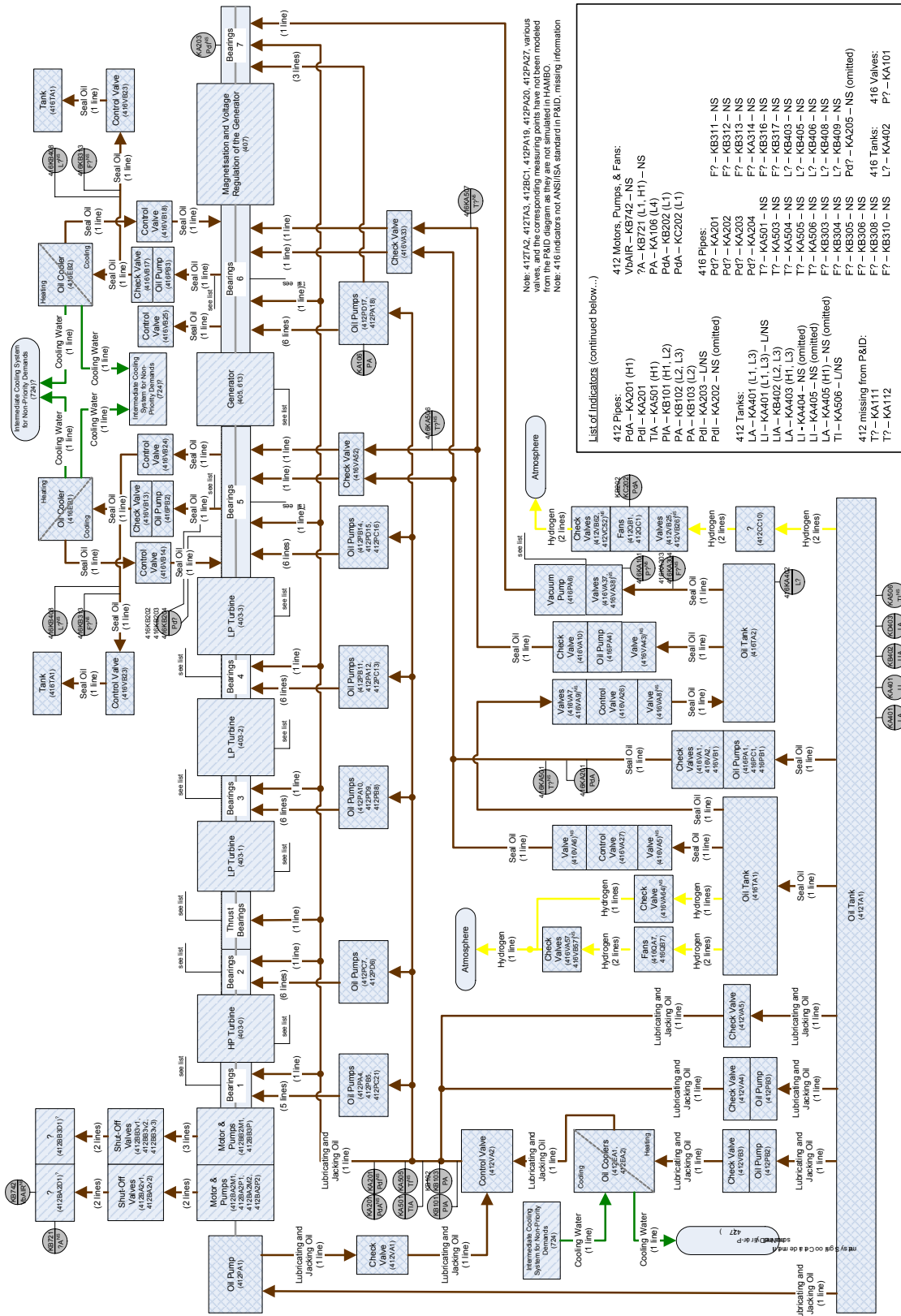

Figure 45: Part-Whole Model of the Lubrication and Jacking Oil, Seal Oil Subsystems

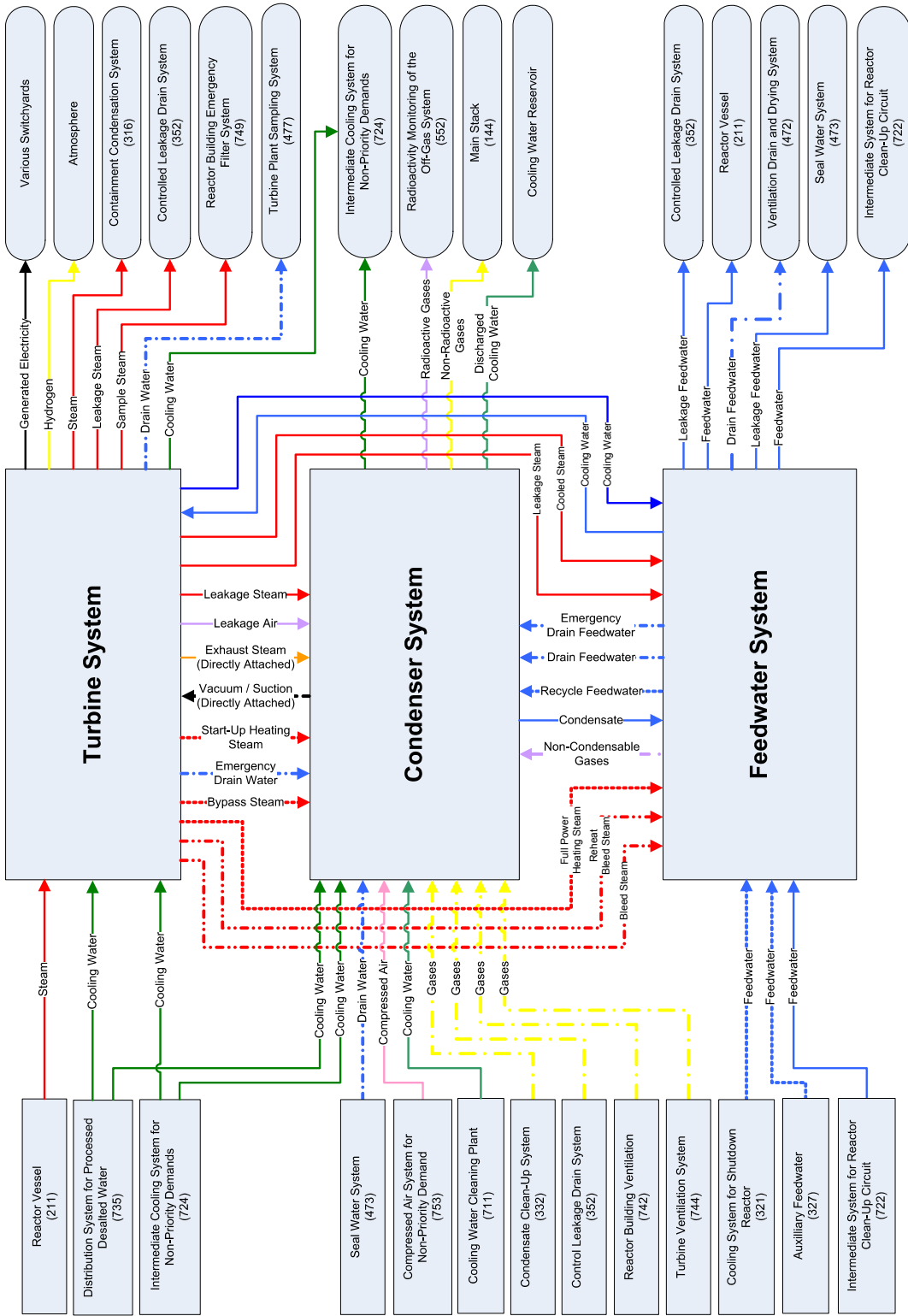

Figure 47: Part-Whole Model of the Secondary Systems at the System Level

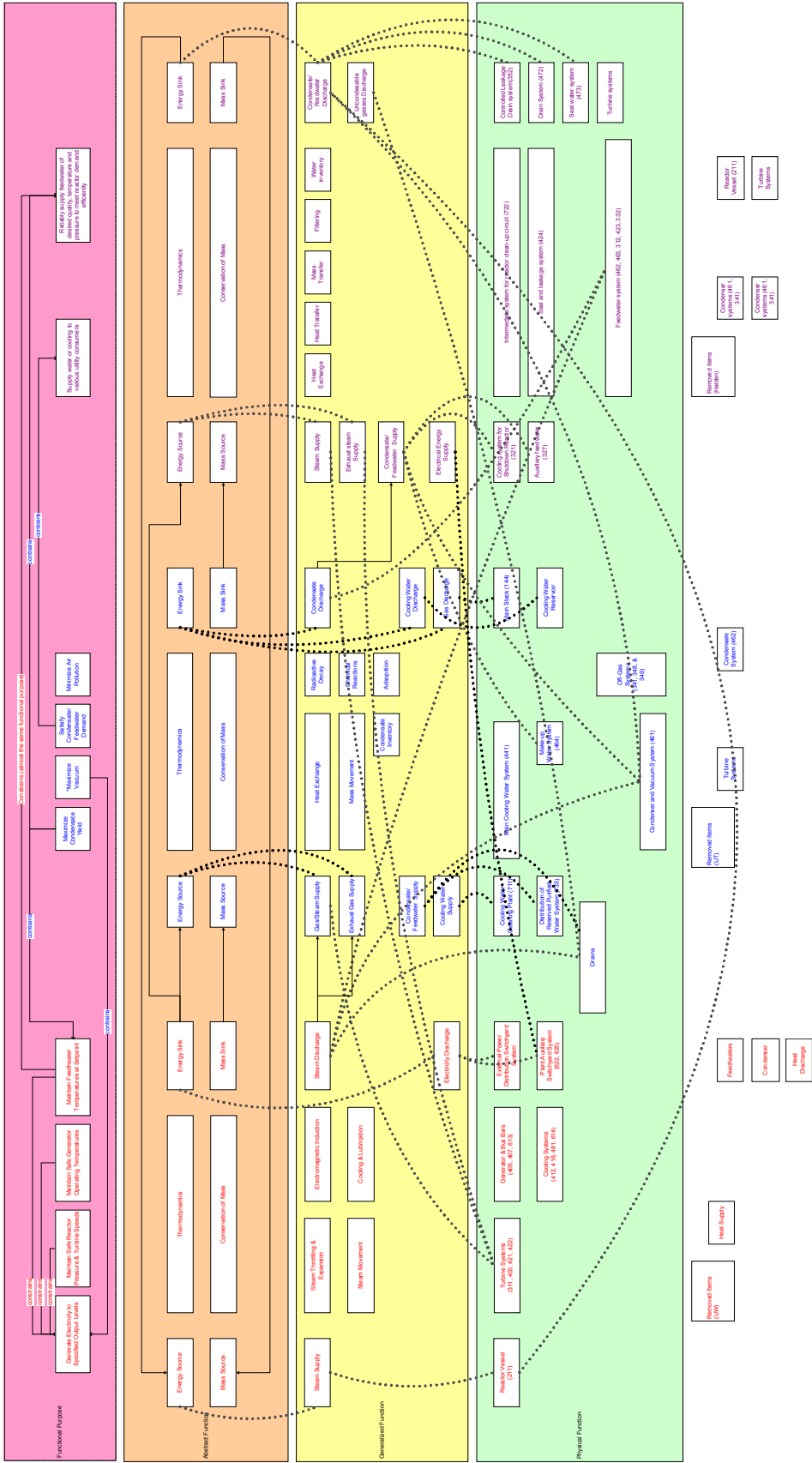

Figure 49: Abstraction Hierarchy of the Secondary Systems at the System Level (Adapted from Lau, 2006)

Appendix D

Information Analysis Tables

Table 19: Condensed Information Requirements for Turbine Secondary Systems at System Level

Variable	Units	Availability	Constraints	Relationships
Turbine load	%	Measured: 531KA077	Normal: 109% Minimum: 0% Maximum: 140%	Directly related to % open of turbine control / throttle valves (T-FP-2-002).
Turbine rotation speed	rpm	Measured: 452KA812, 452KA813, 452KA814	109% Load: 1,500 rpm Minimum: 0 rpm Maximum: 1,875 rpm L1 (452KA812): 1,490 rpm	
Turbine pressures	kPa, bar	Measured: 421KA101-102, 421KB101-102 (HP) Measured: 422KA109-111 (LP)	109% Load: 6.7 MPa (HP), 0.77 MPa (LP) Minimum: 0 MPa (HP) Maximum: 9 MPa (HP), 1 MPa (LP)	
Generator active power (after transformer)	MW	Measured: 689KA911	109% Load: - Minimum: 0 MW Maximum: 1,442 MW	
Generator active power (before transformer)	MW	Measured: 613KA901	109% Load: 1,294 MW Minimum: 0 MW Maximum: 1,442 MW	
Generator reactive power	MVAr	Measured: 613KA902	109% Load: - Minimum: -800 MVAr Maximum: 800 MVAr	
Generator temperature	°C	Measured 405KA590-601 Measured: 445KC502, 445KC504 (Indirectly)	Normal: - Minimum: 0°C Maximum: 100°C	
Feedwater temperature	°C	Measured 462KA506-507, 462KA513-514	109% Load: 215°C Minimum: 0°C Maximum: 100°C, 150°C	Feedwater temperature entering feedheaters affects bleed steam flow (T-AF-003).
Feedwater flow rate	kg/s	Measured: 312KA031	109% Load: 1,750 kg/s Minimum: 0 kg/s Maximum: 2,000 kg/s	Feedwater flow entering feedheaters affects bleed steam flow (T-AF-003).
Reactor pressure	kPa, bar	Measured: 211KA111, 211KB111, 211KC111, 211KD111	Minimum: 0 MPa Maximum: 10 MPa H4: 7.3 MPa L2: 6.0 MPa L4: 1.7 MPa L5: 1.2 MPa	
Mass flow rate in from reactor	kg/s	Not Available Measured: 312KA031 (Indirectly)	109% Load: 1,750 kg/s Minimum: 0 kg/s Maximum: 2,000 kg/s	
Mass flow rate out to condenser sink	kg/s	Calculated: (T-AF-1-001) - (T-AF-1-003)	109% Load: 1,750 kg/s Minimum: - Maximum: -	
Mass flow rate out to feedwater sink	kg/s	Calculated: [(T-AF-1-001 * [hf(T-FP-1-008) - hf(Feedheater Inlet)]) / hfg(T-GF-1-011)]	109% Load: - Minimum: - Maximum: -	Affected by feedwater temperature entering feedheaters (F-GF-1-7).
Energy in from reactor	kJ/kg	Calculated: Saturated steam table lookup with temperature and pressure (T-GF-1-001 and T-GF-1-002)	Normal: -2,772.1 kJ/kg Minimum: 0 kJ/kg Maximum: -2,742.1 kJ/kg	
Energy converted: thermal-mechanical	kJ/kg	Calculated: $h(\text{inlet}) - h(\text{outlet}) = hg(T-GF-1-006, T-GF-1-007) - h(T-GF-2-7, T-GF-2-7) @ 12\% \text{ moisture (HP)}$ Calculated: $hf(\text{inlet}) - hf(\text{outlet}) = hg(T-GF-1-006, T-GF-1-007) - h(T-GF-1-008, T-GF-1-009) @ 12\% \text{ moisture (LP)}$	109% Load: - Minimum: - Maximum: 205.83 kJ/kg (HP)	
Energy converted: mechanical-electrical	kJ/s	Measured: 613KA901	109% Load: 1,294,000 kJ/s Minimum: 0 kJ/s Maximum: 1,442,000 kJ/s	
Energy out to condenser sink	kJ/kg	Calculated: Saturated steam table lookup with temperature and pressure (T-GF-1-008, T-GF-1-009)	Normal: -2253.3 kJ/kg Minimum: 0°C Maximum: -2,778.1 kJ/kg	
Energy out to feedwater sink	kJ/kg	Measured: 423VB1, 423VB2 (HP) Calculated: Saturated steam table lookup with temperature and pressure (T-GF-1-010 and T-GF-1-011)	109% Load: -2,798.5 kJ/kg, -2,804.2 kJ/kg (HP) Minimum: 0°C Maximum: -2,803.4 kJ/kg	Should be equal to feedwater energy leaving feedheaters (F-GF-1-7).
Energy out to various switchyards	kJ/s	Measured: 613KA901	109% Load: 1,294,000 kJ/s Minimum: 0 kJ/s Maximum: 1,442,000 kJ/s	
Steam temperature from reactor	°C	Calculated: Saturated steam table lookup temperature at given pressure. (T-GF-1-002) Measured: 211KW560	Normal: 276.8°C Minimum: 0°C Maximum: 300°C	
Steam pressure from reactor	kPa, bar	Measured: 211KA111, 211KB111, 211KC111, 211KD111	Normal: 6.9 MPa Minimum: 0 MPa Maximum: 9 MPa H4: 7.3 MPa L2: 6.0 MPa L4: 1.7 MPa L5: 1.4 MPa	
Pressure difference across turbine control / throttle valves	kPa, bar	Calculated: (T-GF-1-002) - (T-GF-1-007)	Normal: Less than 5% of input pressure Minimum: 0 MPa Maximum: 9 MPa	

Pressure difference across turbines	kPa, bar	Calculated: (T-GF-1-006) - (T-GF-2-?) (HP) Calculated: (T-GF-1-?) - (T-GF-1-009) (LP)	Normal: ~5 MPa (HP), ~1 MPa (LP) Minimum: 0 MPa Maximum: 9 MPa	
Temperature difference across turbines	°C	Calculated: (T-GF-1-001) - (T-GF-2-?) (HP) Calculated: (T-GF-2-?) - (T-GF-008) (LP)	Normal: ~120°C (HP), ~200°C (LP) Minimum: 0°C Maximum: 300°C	
Turbine temperatures	°C	Measured: 421KA501, 421KB502 (HP) Measured: 422KA109-111 (LP)	Normal: 284°C (HP) Minimum: 0°C Maximum: 300°C	
Turbine pressures	kPa, bar	Measured: 421KA101-102, 421KB101-102 (HP) Measured: 422KA109-111 (LP)	109% Load: 6.7 MPa (HP), 0.77 MPa (LP) Minimum: 0 MPa (HP) Maximum: 9 MPa (HP), 1 MPa (LP)	
Steam exhaust temperature	°C	Calculated:	Normal: 80°C Minimum: 0°C Maximum: 90°C	
Steam exhaust pressure	kPa, bar	Measured: 461KA103-105	Normal: 0-15 kPa Minimum: 0 kPa Maximum: 100 kPa H6 = 90 kPa	
Steam bleed temperature	°C	Measured: 423KA501-502 (HP) Measured: 423KA506, 423KA509, 423KA512 (LP)	109% Load: 210°C, 233°C (HP) 109% Load: 80°C, 100°C, 185°C (LP) Minimum: 0°C Maximum: 300°C	
Steam bleed pressure	kPa, bar	Measured: 423KB101-102 (HP) Not Available (LP)	109% Load: - (HP) Minimum: 0 MPa Maximum: 3.5 MPa	Pressure changes in response to temperature change in feedheater shell (F-GF-1-?)
Cooling hydrogen temperature	°C	Not Available	Normal: - Minimum: 0°C Maximum: -°C	
Cooling hydrogen pressure	kPa, bar	Measured: 481KA101	Normal: - Minimum: 0 kPa Maximum: 1000 kPa H1: 620 kPa L1: 580 kPa L2: 350 kPa L3: 20 kPa	
Cooling water temperature	°C	Measured: 445KC501	Normal: - Minimum: 0°C Maximum: 100°C H1: 48°C L1: 30°C	
Cooling water pressure	kPa, bar	Measured: 445KC102	Normal: - Minimum: -100 kPa Maximum: 60 kPa H1: 60 kPa L1: 18 kPa	
Cooling water flow rate	kg/s	Measured: 445KC301-303	Normal: - Minimum: 0 kg/s Maximum: 65 kg/s	
Lubrication oil flow rate	kg/s	Not Available	Normal: - Minimum: 0 kg/s Maximum: - kg/s	
Generator temperature	°C	Measured 405KA590-601 Measured: 445KC502, 445KC504 (Indirectly)	Normal: - Minimum: 0°C Maximum: 100°C	
Generator output current	kA	Measured: 613KA801	109% Load: - Minimum: 0 kA Maximum: 50 kA	
Generator output voltage	kV	Measured: 613KA851	109% Load: 20.5 kV Minimum: 0 kV Maximum: 25 kV	
Auxiliary input current	kA	Measured: 641KA841-842	Normal: - Minimum: 0 kA Maximum: 25 kA	
Auxiliary input voltage	kV	Measured: 641KA891, 641KA893	Normal: - Minimum: 0 kA Maximum: 25 kA, 15 kA	
Turbine rotation speed	rpm	Measured: 452KA812, 452KA813, 452KA814	109% Load: 1,500 rpm Minimum: 0 rpm Maximum: 1,875 rpm L1 (452KA812): 1,490 rpm	
Turbine vibration	mm/s	Measured: 403KA707-710	Normal: - Minimum: 0 mm/s Maximum: 13.5 mm/s H1 = 2 mm/s H2 = 3 mm/s	
Generator vibration	mm/s	Measured: 405KA702-704	Normal: - Minimum: 0 mm/s Maximum: 13.5 mm/s H1 = 2 mm/s H2 = 3 mm/s	
Generator active power (after transformer)	MW	Measured: 689KA911	109% Load: - Minimum: 0 MW Maximum: 1,442 MW	
Generator active power (before transformer)	MW	Measured: 613KA901	109% Load: 1,294 MW Minimum: 0 MW Maximum: 1,442 MW	
Generator reactive power	MVA	Measured: 613KA902	109% Load: - Minimum: -800 MVA Maximum: 800 MVA	
Auxiliary power input	MW	Measured: 641KA901-902, 641KB901-902, 641KC901-902, 641KD901-902	Normal: - Minimum: 0 MW Maximum: 30 MW	
Generator capability	MW	Calculated: Derived on Generator Capability Curve from generator manufacturer.	109% Load: 1,294 MW Minimum: 0 MW Maximum: 1,442 MW	
Auxiliary power demand	MW	Measured: 641KA901-902, 641KB901-902, 641KC901-902, 641KD901-902	Normal: - Minimum: 0 MW Maximum: 30 MW	
External grid demand	MW	Setpoint given by supervisor.	Normal: 1,294 MW Minimum: 0 MW Maximum: 1,442 MW	
Cooling hydrogen storage level	m	Not Available	Normal: - m Minimum: 0 m Maximum: - m	
Cooling water storage level	m	Measured: 445KC401-403	Normal: - m Minimum: 0 m Maximum: 1.45 m	
Lubricating oil storage level	m	Not Available	Normal: - m Minimum: 0 m Maximum: - m	

Table 20: Condensed Information Requirements for Turbine Secondary Systems at Subsystem Level

Variable	Units	Availability	Constraints	Relationships
Turbine load	%	Measured: 531KA077	Normal: 109% Minimum: 0% Maximum: 140%	Directly related to % open of HP turbine control / throttle valves (T-FP-2-002).
Turbine control / throttle valve opening	%	Measured: 421VA1M, 421VA2M, 421VB1M, 421VB2M	Minimum: 0% Maximum: 100%	Depends directly on turbine load set point assuming governor control (T-FP-2-001). Affects steam flow through secondary system (T-AF-2-?) and reactor pressure.
Turbine bypass valve opening	%	Measured: 421VB6M	Minimum: 0% Maximum: 100%	Depends on turbine load set point assuming governor control (T-FP-2-001). Affects steam flow through secondary system (T-AF-2-?) and reactor pressure.
Turbine rotation speed	rpm	Measured: 452KA812, 452KA813, 452KA814	109% Load: 1,500 rpm Minimum: 0 rpm Maximum: 1,875 rpm L1 (452KA812): 1,490 rpm	Affected by % open of HP turbine control / throttle valves during ramp up.
Reactor pressure	kPa, bar	Measured: 211KA111, 211KB111, 211KC111, 211KD111	Minimum: 0 MPa Maximum: 10 MPa H4: 7.3 MPa L2: 6.0 MPa L4: 1.7 MPa L5: 1.2 MPa	Affected by % open of HP turbine control / throttle valves.
HP turbine pressure	kPa, bar	Measured: 421KA101-102, 421KB101-102 (HP)	109% Load: 6.7 MPa (HP) Minimum: 0 MPa (HP) Maximum: 9 MPa (HP)	Affected by % open of HP turbine control / throttle valves.
LP turbine pressure	kPa, bar	Measured: 422KA109-111 (LP)	109% Load: 0.77 MPa (LP) Minimum: 0 MPa (HP) Maximum: 1 MPa (LP)	Affected by % open of LP turbine control / throttle valves.
Mass flow rate through system	kg/s	Not Available Measured: 312KA031 (Indirectly)	109% Load: 1,750 kg/s Minimum: 0 kg/s Maximum: 2,000 kg/s	Affected by % open of HP turbine control / throttle valves.
Generator active power (after transformer)	MW	Measured: 689KA911	109% Load: - Minimum: 0 MW Maximum: 1,442 MW	
Generator active power (before transformer)	MW	Measured: 613KA901	109% Load: 1,294 MW Minimum: 0 MW Maximum: 1,442 MW	
Generator reactive power	MVA	Measured: 613KA902	109% Load: - Minimum: -800 MVA Maximum: 800 MVA	
Generator temperature	°C	Measured: 405KA590-601 Measured: 445KC502, 445KC504 (Indirectly)	Normal: - Minimum: 0°C Maximum: 100°C	
Shaft bearing temperature	°C	Measured: 403KA522, 403KA528, 403KA530, 403KA532, 403KA524, 403KA526, 403KA575, 403KA577, 405KA632, 405KA634, 405KA636	Minimum: 0°C Maximum: 150°C	
Feedwater temperature	°C	Measured: 462KA506-507, 462KA513-514	109% Load: 215°C Minimum: 0°C Maximum: 100°C, 150°C	Feedwater temperature entering feedheaters affects bleed steam flow (T-AF-003).
Feedwater flow	kg/s	Measured: 312KA031	109% Load: 1,750 kg/s Minimum: 0 kg/s Maximum: 2,000 kg/s	Feedwater flow entering feedheaters affects bleed steam flow (T-AF-003).
Mass flow rate in from reactor	kg/s	Not Available Measured: 312KA031 (Indirectly)	109% Load: 1,750 kg/s Minimum: 0 kg/s Maximum: 2,000 kg/s	Affected by % open of HP turbine control / throttle valves.
Mass turbine bypass to condenser sink steam flow rate	kg/s	Not Available	109% Load: - kg/s Minimum: 0 kg/s Maximum: - kg/s	Affected by % open of bypass valves: 421VA3-4, 421VB3-4.
Mass turbine bypass to feedwater sink steam flow rate	kg/s	Not Available	109% Load: - kg/s Minimum: 0 kg/s Maximum: - kg/s	Affected by % open of fine turbine control (bypass) valve: 421VB6.
Mass reheat steam flow rate.	kg/s	Not Available	109% Load: - kg/s Minimum: 0 kg/s Maximum: - kg/s	Affected by % open of reheat steam control valves: 421VA5, 421VB5.
Mass flow rate in to HP turbine	kg/s	Calculated: (T-AF-2-001) - (T-AF-2-002) - (T-AF-2-003) - (T-AF-2-004)	109% Load: 1,750 kg/s Minimum: 0 kg/s Maximum: 2,000 kg/s	Amount of steam admitted per unit time is affected by % open of turbine control / throttle valves, turbine bypass valve, and reheat steam control valve.
Mass flow rate out of HP turbine to reheaters.	kg/s	Calculated: (T-AF-2-004) + (T-AF-2-?)	109% Load: - Minimum: - Maximum: -	
Mass flow rate out of HP turbine to feedwater sink.	kg/s	Calculated: [T-AF-1-001 * [hf(T-FP-1-008) - hf(Feedheater Inlet)]] / hf(T-GF-1-011)	109% Load: - Minimum: - Maximum: -	Affected by feedwater temperature entering feedheaters (F-GF-1-?).
Mass flow rate out of HP turbine to seal and leakage system.	kg/s	Not Available	109% Load: - Minimum: - Maximum: -	
Mass flow rate out of reheaters to LP turbines.	kg/s	Calculated: (T-AF-2-010) + (T-AF-2-011) + (T-AF-2-012) - (T-AF-2-009)	109% Load: - Minimum: - Maximum: -	
Mass flow rate out of reheaters to drains.	kg/s	Not Available	109% Load: - Minimum: - Maximum: -	
Mass flow rate in to LP turbine 1	kg/s	Measured: New points in Integration Platform Calculated:	109% Load: - Minimum: - Maximum: -	Affected by % open of LP turbine control / throttle valves: 422VA24, 422VB24.
Mass flow rate in to LP turbine 2	kg/s	Measured: New points in Integration Platform Calculated:	109% Load: - Minimum: - Maximum: -	Affected by % open of LP turbine control / throttle valves: 422VA25, 422VB25.
Mass flow rate in to LP turbine 3	kg/s	Measured: New points in Integration Platform Calculated:	109% Load: - Minimum: - Maximum: -	Affected by % open of LP turbine control / throttle valves: 422VA26, 422VB26.
Mass flow rate out of LP turbine 1 to feedwater sink.	kg/s	Calculated: [T-AF-1-001 * [hf(T-FP-1-008) - hf(Feedheater Inlet)]] / hf(T-GF-1-011)	109% Load: - Minimum: - Maximum: -	Affected by feedwater temperature entering feedheaters (F-GF-1-?).
Mass flow rate out of LP turbine 2 to feedwater sink.	kg/s	Calculated: [T-AF-1-001 * [hf(T-FP-1-008) - hf(Feedheater Inlet)]] / hf(T-GF-1-011)	109% Load: - Minimum: - Maximum: -	Affected by feedwater temperature entering feedheaters (F-GF-1-?).
Mass flow rate out of LP turbine 3 to feedwater sink.	kg/s	Calculated: [T-AF-1-001 * [hf(T-FP-1-008) - hf(Feedheater Inlet)]] / hf(T-GF-1-011)	109% Load: - Minimum: - Maximum: -	Affected by feedwater temperature entering feedheaters (F-GF-1-?).
Mass flow rate out of LP turbines to condenser sink	kg/s	Calculated: (T-AF-1-001) - (T-AF-1-003)	109% Load: 1,750 kg/s Minimum: - Maximum: -	Affected by % open of HP/LP turbine control / throttle valves.
Mass flow rate out of LP turbines to seal and leakage system.	kg/s	Not Available	109% Load: - Minimum: - Maximum: -	
Steam enthalpy in from reactor	kJ/kg	Calculated: Saturated steam table lookup with temperature and pressure (T-GF-1-001 and T-GF-1-002)	Normal: ~2,772.1 kJ/kg Minimum: 0 kJ/kg Maximum: ~2,742.1 kJ/kg	
Turbine bypass to condenser sink steam enthalpy	kJ/kg	Measured: At bypass valves 421VA3-4, 421VB3-4	Normal: ~2,772.1 kJ/kg Minimum: 0 kJ/kg Maximum: ~2,742.1 kJ/kg	

Turbine bypass to feedwater sink steam enthalpy	KJ/kg	Measured: At turbine fine control (bypass) valve 421VB6	Normal: ~2,772.1 kJ/kg Minimum: 0 kJ/kg Maximum: ~2,742.1 kJ/kg
Reheat steam enthalpy	KJ/kg	Measured: At reheat steam control valves 421VA5, 421VB5	Normal: ~2,772.1 kJ/kg Minimum: 0 kJ/kg Maximum: ~2,742.1 kJ/kg
Steam enthalpy in to HP turbine	KJ/kg	Measured: At HP control / throttle valves 421VA1-2, 421VB1-2	Normal: ~2,772.1 kJ/kg Minimum: 0 kJ/kg Maximum: ~2,742.1 kJ/kg
HP turbine leaving loss	KJ/kg	Calculated:	Normal: - kJ/kg Minimum: - kJ/kg Maximum: - kJ/kg
Steam enthalpy out of HP turbine to reheaters	KJ/kg	Calculated: Saturated steam table lookup with temperature and pressure (T-GF-2-? and T-GF-2-?) @ 12% moisture rate.	Normal: - Minimum: 0 kJ/kg Maximum: ~2,742.1 kJ/kg
Steam enthalpy out of HP turbine to feedwater sink	KJ/kg	Measured: At block valves 423VB1-2, control valves 423VA31-32.	Normal: - Minimum: 0 kJ/kg Maximum: ~2,742.1 kJ/kg
Steam enthalpy out of HP turbine to seal and leakage system.	KJ/kg	Not Available	Normal: - Minimum: 0 kJ/kg Maximum: ~2,742.1 kJ/kg
Steam and water enthalpy out of reheaters to drains	KJ/kg	Not Available	Normal: - Minimum: 0 kJ/kg Maximum: ~2,742.1 kJ/kg
Steam enthalpy out of reheaters to LP turbine 1	KJ/kg	Measured: At control valve 422VA24, 422VB24	Normal: - Minimum: 0 kJ/kg Maximum: ~2,742.1 kJ/kg
Steam enthalpy out of reheaters to LP turbine 2	KJ/kg	Measured: At control valve 422VA25, 422VB25	Normal: - Minimum: 0 kJ/kg Maximum: ~2,742.1 kJ/kg
Steam enthalpy out of reheaters to LP turbine 3	KJ/kg	Measured: At control valve 422VA26, 422VB26	Normal: - Minimum: 0 kJ/kg Maximum: ~2,742.1 kJ/kg
LP turbine 1 leaving loss	KJ/kg	Calculated:	Normal: - kJ/kg Minimum: - kJ/kg Maximum: - kJ/kg
LP turbine 2 leaving loss	KJ/kg	Calculated:	Normal: - kJ/kg Minimum: - kJ/kg Maximum: - kJ/kg
LP turbine 3 leaving loss	KJ/kg	Calculated:	Normal: - kJ/kg Minimum: - kJ/kg Maximum: - kJ/kg
Steam enthalpy out of LP turbine 1 to feedwater sink	KJ/kg	Measured: New points in Integration Platform Calculated:	Normal: - Minimum: 0 kJ/kg Maximum: ~2,742.1 kJ/kg
Steam enthalpy out of LP turbine 2 to feedwater sink	KJ/kg	Measured: New points in Integration Platform Calculated:	Normal: - Minimum: 0 kJ/kg Maximum: ~2,742.1 kJ/kg
Steam enthalpy out of LP turbine 3 to feedwater sink	KJ/kg	Measured: New points in Integration Platform Calculated:	Normal: - Minimum: 0 kJ/kg Maximum: ~2,742.1 kJ/kg
Steam enthalpy out of LP turbines to condenser sink	KJ/kg	Calculated: $[(T-AF-2-029 + T-AF-2-030 + T-AF-2-031) / 3] - [(T-AF-2-032 + T-AF-2-033 + T-AF-2-034) / 3] - [(T-AF-2-035 + T-AF-2-036 + T-AF-2-037) / 3]$ - (thermal energy converted to electrical energy)	Normal: - Minimum: 0 kJ/kg Maximum: ~2,742.1 kJ/kg
Steam enthalpy out of LP turbines to seal and leakage system	KJ/kg	Not Available	Normal: - Minimum: 0 kJ/kg Maximum: ~2,742.1 kJ/kg
Rate of mechanical energy from HP turbine transferred to shaft	KJ/s	Calculated:	109% Load: - kJ/s Minimum: - kJ/s Maximum: - kJ/s
Rate of mechanical energy from LP turbines transferred to shaft	KJ/s	Calculated:	109% Load: - kJ/s Minimum: - kJ/s Maximum: - kJ/s
Rate of electrical energy generated from mechanical energy in shaft	KJ/s	Measured: 613KA901 Calculated:	109% Load: 1,294 kJ/s Minimum: 0 kJ/s Maximum: 1,442 kJ/s
Mass flow rate of oil to bearings from storage tank.	kg/s	Not Available	
Mass flow rate of oil to generator from storage tank	kg/s	Not Available	
Mass flow rate of cooling water to generator from storage tank	kg/s	Measured: 445KC301-303	Normal: - Minimum: 0 kg/s Maximum: 65 kg/s
Mass flow rate of cooling water to bus bars from storage tank	kg/s	Calculated:	
Mass flow rate from reactor to drains	kg/s	Calculated:	
Steam temperature from reactor	°C	Calculated: Saturated steam table lookup temperature at given pressure. (T-GF-1-002) Measured: 211KW560	Normal: 276.8°C Minimum: 0°C Maximum: 300°C
Steam pressure from reactor	kPa, bar	Measured: 211KA111, 211KB111, 211KC111, 211KD111	Normal: 6.9 MPa Minimum: 0 MPa Maximum: 9 MPa H4: 7.3 MPa L2: 6.0 MPa L4: 1.7 MPa L5: 1.4 MPa
Bypass to condenser sink steam temperature	°C	Measured: 421KA505-506, 421KB505-506	109% - °C Minimum: 0°C Maximum: 300°C
Bypass to condenser sink steam pressure	kPa, bar	Not Available	
Bypass to feedwater sink steam temperature	°C	Measured:	
Bypass to feedwater sink steam pressure	kPa, bar	Not Available	
Reheat steam temperature	°C		
Reheat steam pressure	kPa, bar		
Temperature of steam at HP turbine control / throttle valves	°C		
Pressure of steam at HP turbine control / throttle valves	kPa, bar		
Temperature of steam in to HP turbine	°C		
Pressure of steam in to HP turbine	kPa, bar		
Temperature of bleed steam from HP turbine to feedwater sink	°C		
Pressure of bleed steam from HP turbine to feedwater sink	kPa, bar		
Temperature of steam and water from reheaters to drains	°C		
Pressure of steam and water from reheaters to drains	kPa, bar		
Temperature of steam from HP turbine in to reheaters	°C	Measured: 422KA501	
Pressure of steam from HP turbine in to reheaters	kPa, bar	Measured: 422KA103	
Temperature of steam from reheaters to LP turbine 1	°C		

Pressure of steam from reheaters to LP turbine 1	kPa, bar				
Temperature of steam from reheaters to LP turbine 2	°C				
Pressure of steam from reheaters to LP turbine 2	kPa, bar				
Temperature of steam from reheaters to LP turbine 3	°C				
Pressure of steam from reheaters to LP turbine 3	kPa, bar				
Temperature of bleed steam from LP turbine 1 to feedwater sink	°C				
Pressure of bleed steam from LP turbine 1 to feedwater sink	kPa, bar				
Temperature of bleed steam from LP turbine 2 to feedwater sink	°C				
Pressure of bleed steam from LP turbine 2 to feedwater sink	kPa, bar				
Temperature of bleed steam from LP turbine 3 to feedwater sink	°C				
Pressure of bleed steam from LP turbine 3 to feedwater sink	kPa, bar				
Temperature of steam from LP turbines to condenser sink	°C	Calculated		Normal: 80°C Minimum: 0°C Maximum: 90°C	There is no measuring points directly on LP outlets.
Pressure of steam from LP turbines to condenser sink	kPa, bar	Measured: 461KA103-105		Normal: 0-15 kPa Minimum: 0 kPa Maximum: 100 kPa PS = 90 kPa	Measuring point is absolute pressure, i.e. value = atmospheric pressure - vacuum pressure. There is no measuring points directly on LP outlets.
Steam moisture in HP turbine	%	Not Available		Normal: - % Minimum: 0% Maximum: 13-14%	Excessive moisture degrades efficiency and lifespan of turbines, as well as reduces efficiency. Needs moisture separator and reheating to lower moisture from 10% to 1%.
Steam moisture in LP turbine 1	%	Not Available		Normal: 1% (LP) Minimum: 0% Maximum: 13-14%	Excessive moisture degrades efficiency and lifespan of turbines, as well as reduces efficiency. Needs moisture separator and reheating to lower moisture from 10% to 1%.
Steam moisture in LP turbine 2	%	Not Available		Normal: 1% (LP) Minimum: 0% Maximum: 13-14%	Excessive moisture degrades efficiency and lifespan of turbines, as well as reduces efficiency. Needs moisture separator and reheating to lower moisture from 10% to 1%.
Steam moisture in LP turbine 3	%	Not Available		Normal: 1% (LP) Minimum: 0% Maximum: 13-14%	Excessive moisture degrades efficiency and lifespan of turbines, as well as reduces efficiency. Needs moisture separator and reheating to lower moisture from 10% to 1%.
Cooling hydrogen temperature	°C	Not Available		Normal: 0°C Minimum: 0°C Maximum: -°C	
Cooling hydrogen pressure	kPa, bar	Measured: 481KA101		Normal: 0 kPa Minimum: 0 kPa Maximum: 1000 kPa H1: 620 kPa L1: 580 kPa L2: 350 kPa L3: 20 kPa	
Cooling water temperature	°C	Measured: 445KC501		Normal: - Minimum: 0°C Maximum: 100°C H1: 48°C L1: 39°C	Note: This measures temperature of water before generator / stator. Temperature of water flowing out of the generator / stator is measured by 445KC502-504.
Cooling water pressure	kPa, bar	Measured: 445KC102		Normal: - Minimum: -100 kPa Maximum: 60 kPa H1: 60 kPa L1: 15 kPa	Note: This measures pressure in water tank before being pumped into generator / stator.
Cooling water flow rate	kg/s	Measured: 445KC301-303		Normal: - Minimum: 0 kg/s Maximum: 65 kg/s	
Generator temperature	°C	Measured: 405KA590-601 Measured: 445KC502, 445KC504 (indirectly)		Normal: 0°C Maximum: 100°C	Heat removed from generator by the water in generator cooling system can indirectly measure temperature.
Generator output current	KA	Measured: 613KA801		100% Load: Minimum: 0 kA Maximum: 50 kA	
Generator output voltage	KV	Measured: 613KA851		100% Load: 20.5 kV Minimum: 0 kV Maximum: 25 kV	
Auxiliary input current	KA	Measured: 641KA841-842		Normal: Minimum: 0 kA Maximum: 25 kA	
Auxiliary input voltage	KV	Measured: 641KA891, 641KA893		Normal: Minimum: 0 kA Maximum: 25 kA, 15 kA	
Turbine control / Throttle valve opening	%	Measured: 421VA1M, 421VA2M, 421VB1M, 421VB2M		Minimum: 0% Maximum: 100%	Depends directly on turbine load set point assuming governor control (T-PP-2-001). Affects steam flow through secondary system (T-AF-2-7) and reactor pressure.
Turbine rotation speed	rpm	Measured: 452KA812, 452KA813, 452KA814		100% Load: 1,500 rpm Minimum: 0 rpm Maximum: 1,875 rpm L1 (452KA812): 1,490 rpm	
Turbine vibration	mm/s	Measured: 403KA707-710		Normal: Minimum: 0 mm/s Maximum: 13.5 mm/s H1 = 2 mm/s H2 = 3 mm/s	Excessive vibration may cause damage to the turbines, indicative of friction. Frequency data not simulated.
Generator vibration	mm/s	Measured: 405KA702-704		Normal: Minimum: 0 mm/s Maximum: 13.5 mm/s H1 = 2 mm/s H2 = 3 mm/s	Excessive vibration may cause damage to the generator, indicative of friction. Frequency data not simulated.
Generator active power (after transformer)	MW	Measured: 669KA911		100% Load: Minimum: 0 MW Maximum: 1,442 MW	Power measured after/on main transformer.
Generator active power (before transformer)	MW	Measured: 613KA901		100% Load: 1,294 MW Minimum: 0 MW Maximum: 1,442 MW	Primary variable used to monitor power generated vs. setpoint for a specific load. Power in bus bars after generator to transformers.
Generator reactive power	MVA	Measured: 613KA902		100% Load: Minimum: -800 MVA Maximum: 800 MVA	Power in bus bars after generator to transformers. Not simulated exactly in HAMB0.
Auxiliary power input	MW	Measured: 641KA901-902, 641KB901-902, 641KC901-902, 641KD901-902		Normal: Minimum: 0 MW Maximum: 30 MW	Must take internal power consumption into consideration when looking at overall efficiency of plant.
Generator capability	MW	Calculated: Derived on Generator Capability Curve from generator manufacturer.		100% Load: 1,294 MW Minimum: 0 MW Maximum: 1,442 MW	
Auxiliary power demand	MW	Measured: 641KA901-902, 641KB901-902, 641KC901-902, 641KD901-902		Normal: Minimum: 0 MW Maximum: 30 MW	
External grid demand	MW	Setpoint given by supervisor.		Normal: 1,284 MW Minimum: 0 MW Maximum: 1,442 MW	
Cooling hydrogen storage level	m	Not Available		Normal: - m Minimum: 0 m Maximum: - m	
Cooling water storage level	m	Measured: 445KC401-403		Normal: - m Minimum: 0 m Maximum: 1.45 m	
Lubricating oil storage level	m	Not Available		Normal: - m Minimum: 0 m Maximum: - m	

Appendix E

First Iteration of Ecological Interface Design

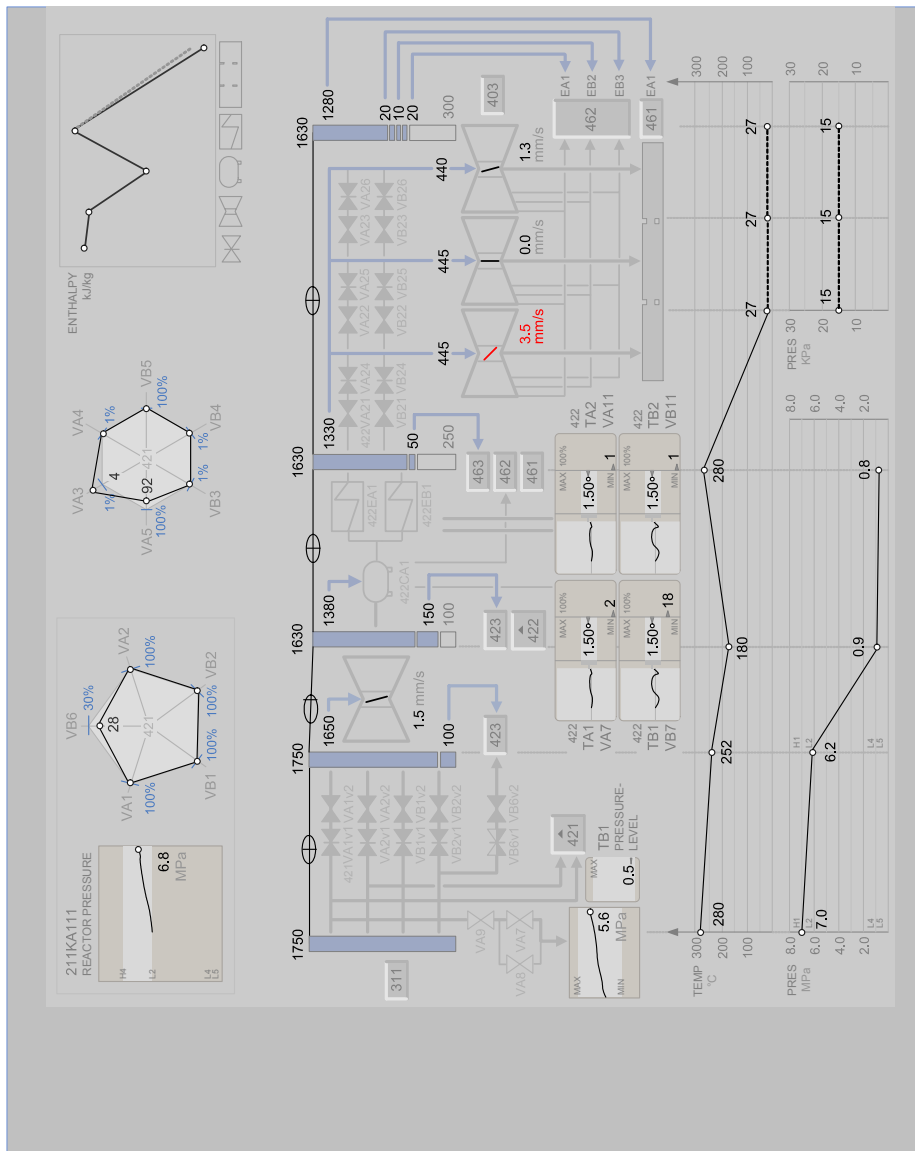

Figure 50: Steam Related Subsystems of Turbine Secondary Systems

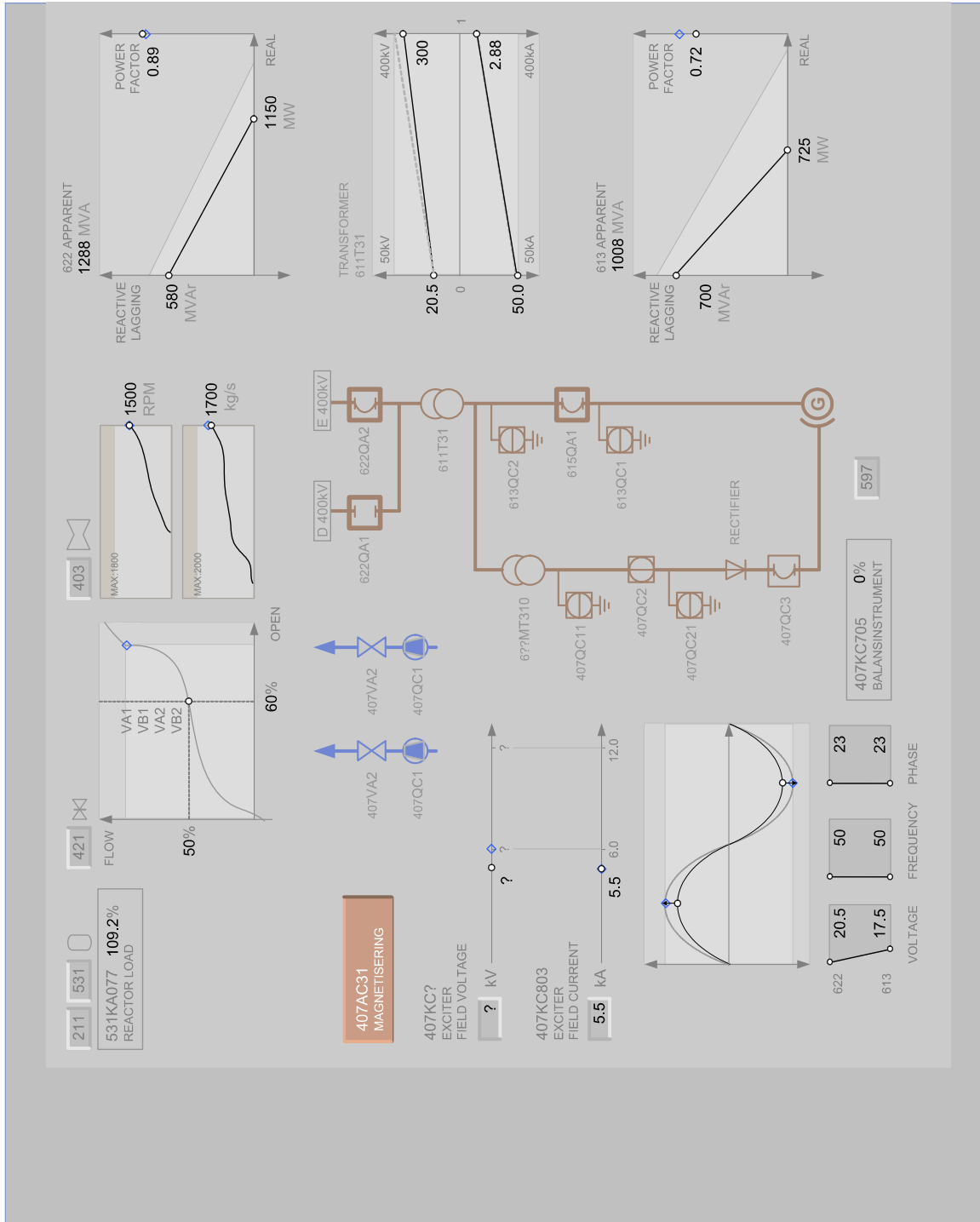

Figure 51: Electrical Related Subsystems of Turbine Secondary Systems

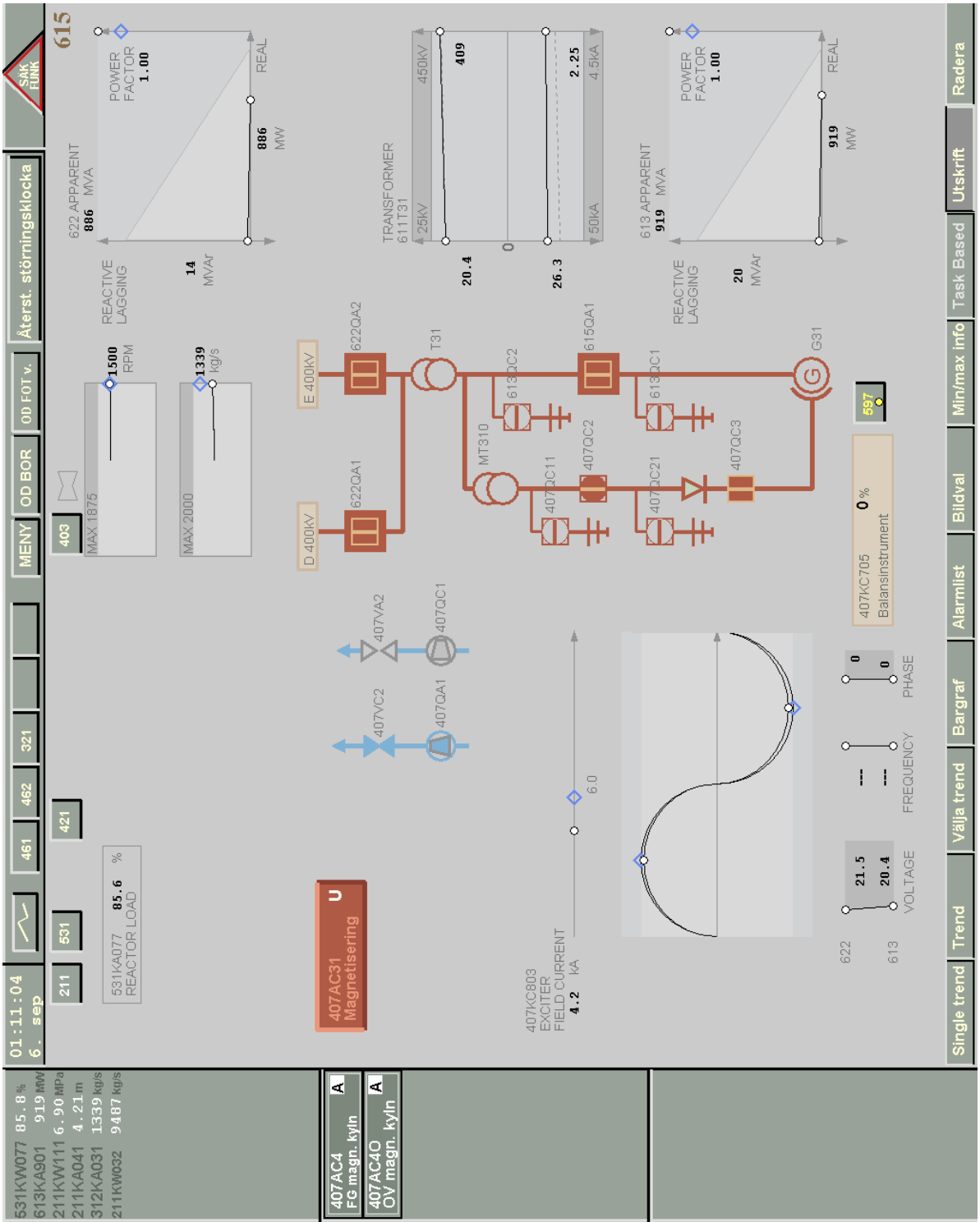

Figure 54: Screenshot of Generator Subsystem in Turbine Secondary Systems

Appendix G

HOPE: Level of Understanding (LoU) Scale

The following description of the LoU scale is reproduced from Skraaning Jr., Nihlwing, Welch, and Veland (2005b) for accessibility. The process expert scores the operator understanding of the process situation for each probe on a simple LoU scale:

- 3 Full understanding
- 2 Good understanding
- 1 Some understanding
- 0 Poor understanding

This scoring is done immediately when the operator has responded to the probe, and the simulator is running again after the mini-freeze. The scale should be interpreted in the following way:

Full understanding: Full understanding means that the operator has, (a) detected all process deviations that occurred before an alarm annunciation, (b) has reached a fully correct diagnosis, and/or (c) has a fully correct understanding behind the problem solving or execution of tasks.

Good understanding: Good understanding means that the operator has, (a) detected all process deviations that occurred, (b) has reached a mostly correct diagnosis, and/or (c) has a mostly correct understanding behind the problem solving or execution of tasks.

Some understanding: Some understanding means that the operator has, (a) detected some process deviations that occurred, (b) has reached a partly correct diagnosis, and/or (c) has a partly correct understanding behind the problem solving or execution of tasks.

Poor understanding: Poor understanding means that the operator has, (a) not detected the process deviations that occurred, or falsely detected process deviations that did not occur, (b) has not reached a diagnosis, or reached a wrong diagnosis, and/or (c) has no understanding, or an incorrect understanding behind the problem solving or execution of tasks. Thus, both ignorance and misunderstanding indicate poor LoU.

Note: It is virtually impossible to differentiate between ignorance and misunderstanding: Misunderstanding may sometimes lead to full understanding later in the scenario, i.e.

through learning by trial and error within the limits of the system's error tolerance. Ignorance, or lack of understanding, indicates a passive approach that may correctly leave everything to automation and emergency systems in certain situations. On the other hand, ignorance or misunderstanding can lead to severe economical/safety consequences at other times. It will therefore vary whether ignorance or misunderstanding indicates the poorest LoU, and the exact range order can typically not be revealed by short scenarios. Additionally, the semantic difference between ignorance and misunderstanding is not clear cut.

Appendix H

Screen Layouts

The following screen layout was proposed in Skraaning Jr., Welch, and Veland (2005) and implemented in the experiment:

Reactor Operator Side (Left)

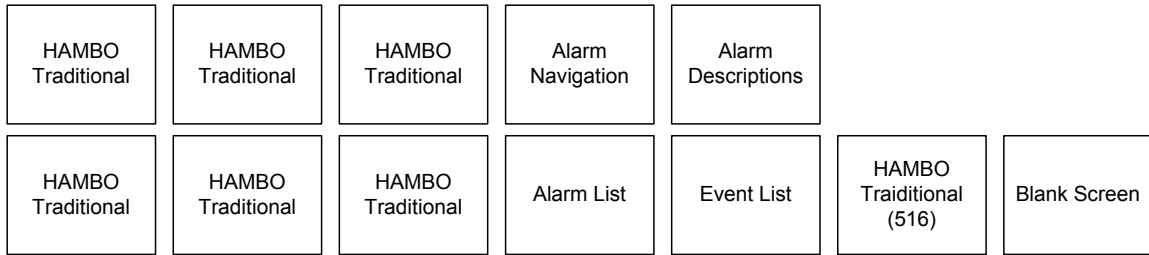

Turbine Operator Side (Right)



Figure 55: Experiment Screen Layouts

In the Traditional Single Sensor-Single Indicator condition, the EID displays (highlighted in blue) are replaced with the equivalent HAMBO Traditional displays. Likewise, in the Advanced User Centered Design condition, the HAMBO Traditional and EID displays were replaced by the equivalent Advanced HAMBO displays.



Figure 56: Screen Positioning in Control Room (Skraaning Jr., 2005)

Between the reactor operator and turbine operator sets of screens is a large-screen display of the overall plant processes. Note that a HAMBO version of the large-screen display was used for the EID condition. As well, the front-most row of screen is intended for a shift supervisor, excluded from the present experiment.

Appendix I

University of Waterloo Ethics Application

UNIVERSITY OF WATERLOO OFFICE OF RESEARCH ETHICS

APPLICATION FOR ETHICS REVIEW OF RESEARCH INVOLVING HUMAN PARTICIPANTS

A. GENERAL INFORMATION

1. **Title of Project:** Halden Reactor Project

2. **Principal Investigator**

Faculty [] Post-doctoral [] Administration []

Name	Department	Ext:	e-mail:
Greg A. Jamieson	Mechanical & Industrial Engineering (University of Toronto)		jamieson@mie.utoronto.ca

3. **Co-Investigator(s)**

Faculty [] Post-doctoral [] Administration []

Name	Department	Ext:	e-mail:
Greg A. Jamieson	Mechanical & Industrial Engineering (University of Toronto)		jamieson@mie.utoronto.ca

4. **Faculty Supervisor(s)** **Department** **Ext:** **e-mail:**

Catherine M. Burns	Systems Design Engineering	3903	
--------------------	----------------------------	------	--

c4burns@engmail.uwaterloo.ca

5. **Student Investigator(s)** **Department** **Ext:** **e-mail:**

Jordanna Kwok	Systems Design Engineering	4904	
---------------	----------------------------	------	--

j2kwok@engmail.uwaterloo.ca

Local Telephone Number: 519-589-8891

6. **Level of Project:**

Faculty Research [] Post-doctoral Research []

Thesis Research:

Ph.D. [] M.A. [] M.Acc. [] M.E.S. [] M.A.Sc. [X]
M.Math. [] M.Phil. [] M.Sc. [] Honours []

Non-thesis Course Projects: Undergraduate [] Graduate []
Specify course and number:

Administration []

Other, specify:

Research Project/Course Status:

New Project/Course [X] Renewal [] of ORE # _____ Pilot Research []

7. Funding Status:

Is this project currently funded? **Yes [X] No []**

If **Yes**, provide: Name of Sponsor NSERC Special Opportunities

Period of Funding: 2 Years

If **No**, is funding being sought? **Yes [] No []**

Name of Sponsor (s)

Period of Funding:

8. Is this research a multi-centre study? Yes [X] No []

If **Yes**, what other institutions are involved?

University of Toronto, Institute for Energy Technology (IFE) in Halden, Norway

9. Has this proposal been submitted to any other Research Ethics Board/Institutional Review Board? Yes [X] No []

If **Yes**, provide the name of the REB/IRB, date of ethics review, and decision.

Ethics Review Office (University of Toronto) – Approved on November 10, 2005 (see Appendix I.F)

Human Studies Review Committee (IFE) – Approved on April 15, 2005 (see Appendix I.E)

10. For Undergraduate and Graduate Thesis Research:

Has this proposal received approval of a Department Thesis Committee?

Yes [] No, approval pending [] No, not a departmental requirement [X]

If **Yes or Approval pending**, provide approval date:

11. a. Indicate the anticipated commencement date for this project: January 3, 2006

b. Indicate the anticipated completion date for this project: February 2, 2006

B. SUMMARY OF PROPOSED RESEARCH

1. Purpose and Rationale for Proposed Research

- a. Briefly describe the purpose (objectives) and rationale of the proposed project and include any hypothesis(es)/research questions to be investigated. Where available, include a copy of the research proposal.

Purpose: The Halden Reactor Project seeks to investigate the effects of human-machine interface (HMI) designs on nuclear power plant operator behaviour in relation to performance. Human performance has been cited as one of the foremost critical factors in nuclear power plant safety; thus, it is important to evaluate novel and innovative HMI design approaches for possible effects on performance. The main objective of the proposed study is to compare the effectiveness of two HMI design approaches (Ecological Interface Design vs. User-Centered Design) for two different types of events (anticipated vs. unanticipated).

Hypotheses: An interaction is expected between the two HMI design approaches and the two types of events in relation to the effectiveness of operator behaviours, i.e. performance. During anticipated events, no differences are expected in operator performance between the two HMI designs. During unanticipated events, degradation in operator performance is expected, but will be more pronounced in the User-Centered Design HMI than in the Ecological Interface Design HMI.

- b. In **LAY LANGUAGE**, provide a one paragraph (approximately 100 words) summary of the project including purpose, the anticipated potential benefits, and basic procedures used.

Nuclear power plants are monitored and controlled by operators in control rooms via human-machine interfaces (HMI). Nuclear power plant safety is affected operator performance, which is in turn enhanced or restricted by the design of the HMI. The proposed study is an international intends to evaluate a relatively new design methodology known as Ecological Interface Design (EID) in comparison to a more traditional User-Centered Design approach. It is one of many studies under the Halden Reactor Project, an international research program for the advancement of nuclear power technology. The results of the study will provide both HMI designers and users with valuable feedback on the two design approaches, in particular whether the EID methodology can be applied to improve operator performance. Participants will first be trained to use the HMIs on a plant simulator and will then operate through several scenarios containing anticipated and unanticipated events from which non-invasive measurements will be taken. Following the trials, a short interview will be given to probe overall experience.

2. Methodology/Procedures

- a. **Which of the following procedures will be used? Provide a copy of all materials to be used in this study.**

**Note: For studies that only use tissue/body fluid specimens from other sources, use ORE Form 101T*

Survey(s) or questionnaire(s) (mail-back) Are they standardized? All Some None

Survey(s) or questionnaire(s) (in person) Are they standardized? All Some None

Computer-administered task(s) or survey(s) Are they standardized? All Some None

Interview(s) (in person)

Interview(s) (by telephone)

Focus group(s)

Audiotaping

- [X] Videotaping
- [] Invasive physiological measurement
 - [] Venipuncture
 - [] Catheter insertions
 - [] Muscle biopsies
 - [] Other tissue samples Specify
 - [] Other Specify
 - [] Non-invasive physiological measurement
 - [] Exercise
 - [] Muscle stimulation
 - [] Electromyography
 - [] Heart rate
 - [] Blood pressure
 - [] Other (specify)
- [] Analysis of secondary data set (no involvement with human participants)
- [X] Unobtrusive observations
- Other (specify)

b. Provide a brief, sequential description of the procedures to be used in this study. For studies involving multiple procedures or sessions, use of a flow chart is recommended.

The study will be carried out on a plant simulator with which the participants have prior experience. During training sessions, participants are put into teams of four (4). During scenario trial sessions, participants are put into teams of two (2). Scenario teams will be participating either in the morning (08:00-14:00) or in the evening (15:00-21:00). During each scenario trial, participants will be asked a variety of questions to assess their knowledge of the situation as well as their performance. Following each scenario trial, a Task Complexity Questionnaire concerning mental workload will be administered (Appendix I.C). At the end of all scenario trials, the participants will be debriefed. The experiment will be conducted over a period of three (3) days for each scenario team:

Day 1:

1. Introduction (0.5 hours): Informed consent (Appendix I.A), demographic questionnaire (Appendix I.B), and opportunity for participant questions.
2. Training (3.0 hours): Participants will be trained in the operation of the HMI.
3. Lunch break (1.0 hours).
4. Training (3.0 hours): Participants will be trained in the operation of the HMI.

Day 2:

1. Training (1.0 hours): Participants (morning) will be trained in the operation of the HMI.
2. Break (0.15 hours).
3. Scenario 1 Trial (1.0 hours): The participants (morning) will complete the first scenario.
4. Break (0.15 hours).
5. Scenario 2 Trial (1.0 hours): The participants (morning) will complete the second scenario.
6. Lunch break (1.00 hours).
7. Scenario 3 Trial (1.0 hours): The participants (morning) will complete the third scenario.
8. Break (1.00 hours).

Other (specify): Potential participants will be recruited from Swedish nuclear power plant licensees.

- b. Describe the potential participants in this study including group affiliation, gender, age range and any other special characteristics. If only one gender is to be recruited, provide a justification for this.**

For the purpose of this project, participants will be professional, licensed, plant operators who are qualified to operate the control system being simulated in the study. Participants are employees of a Swedish power plant licensee who is a member of the Halden Reactor Project. The licensee and employees are well aware of the activities and research conducted by the Halden Reactor Project. Qualified operators are familiar with the operation of the simulator to be used in the study. No member of the target population will be excluded from the study by investigators.

- c. How many participants are expected to be involved in this study?** 12

4. Recruitment Process and Study Location

- a. From what source(s) will the potential participants be recruited?**

- UW undergraduate and/or graduate classes
- UW Psychology Research Experiences Group
- Other UW sources (specify):
- Local School Boards (ORE Form 102 must be completed)
- Kitchener-Waterloo Community
- Agencies
- Businesses, Industries, Professions
- Health care settings, nursing homes, correctional facilities, etc.

Other, specify (e.g. mailing lists): Swedish nuclear power plant licensee

- b. Identify who will recruit potential participants and describe the recruitment process.**

Provide a copy of any materials to be used for recruitment (e.g. posters(s), flyers, advertisement(s), letter(s), telephone and other verbal scripts).

Potential participants will be recruited on a voluntary basis by the Norwegian Institute for Energy Technology (IFE) and the licensee of Swedish nuclear power plants. The Division Head of Operation Centre at the IFE will send out a request for participants to a management representative responsible for production (contact personnel). The contact personnel will then forward the request verbally to the qualified plant operators who may in turn respond to participate in the study. The contact personnel is instructed to inform potential participants that participation is completely voluntary and their decision will not affect their job status or relationship with the nuclear power plant licensee. All participants will then be informed and eligible to participate. Please note that the recruitment materials are not available in English.

- c. Where will the study take place? If procedures involve direct contact with participants or occur in an off-campus setting, please ensure question D2 is completed.**

On campus Location

Off campus Location Institute for Energy Technology in Halden, Norway

5. Compensation of Participants

Will participants receive compensation (financial or otherwise) for participation?

Yes [] No [] If Yes, provide details:

Participants will be compensated in accordance with their employment contracts (through salary) with the licensee of the plants. All travel expenses associated with the study will be covered through the Halden Reactor Project. Individuals who elect not to participate will not be penalised in any way.

6. Feedback to Participants

Briefly describe the plans for provision of feedback and attach a copy of the feedback letter to be used. Wherever possible, written feedback should be provided to study participants including a statement of appreciation, details about the purpose and predictions of the study, contact information for the researchers, and the ethics review and clearance statement. Refer to the Checklist for Feedback Sheets on ORE web site:

<http://www.research.uwaterloo.ca/ethics/human/samples/checklistfeedback.htm>

Note: When available, a copy of an executive summary of the study outcomes also should be provided to participants.

Participants will be debriefed and given feedback upon completing the experiment. Please note that the feedback materials are not available in English.

C. POTENTIAL BENEFITS FROM THE STUDY

1. Identify and describe any known or anticipated direct benefits to the participants from their involvement in the project.

Participants will gain experience operating state-of-the-art Human-Machine Interfaces with meaningful event scenarios. Operating tasks in the study are very similar to normal training activities (i.e. additional training), which may lead to better understanding of the target system.

2. Identify and describe any known or anticipated benefits to the scientific community/society from this study.

Results from the project will allow for improvements to be made in the design of Human-Machine Interfaces (HMI) in nuclear power plants, which can lead to better safety and efficiency. It may also be possible to generalise the results for other control process industries such as petrochemical plants, refineries, and chemical manufacturers.

D. POTENTIAL RISKS TO PARTICIPANTS FROM THE STUDY

1. For each procedure used in this study, provide a description of any known or anticipated risks/stressors to the participants. Consider physiological, psychological, emotional, social, economic, etc. risks/stressors. A study-specific medical screening form must be included when physiological assessments are used and the associated risk(s) to participants is minimal or greater.

[] No known or anticipated risks
Explain why no risks are anticipated:

- Minimal risk
Description of risks:

Participants will be asked to perform monitoring and control tasks on a nuclear power plant simulator that is intended to replicate the operators' usual work environment. There is one anticipated risk: participants may become frustrated while performing some of the tasks. The frustration that may be experienced by the participants will be at the same level as that found in routine training exercises. That is, the scenarios performed in the experiment are similar to the scenarios found in the training exercises. This type of training is provided as a normal part of their job, which includes the handling of stressful situations. The risk is expected and should not be undue.

- Greater than minimal risk
Description of risks:

2. Describe the procedures or safeguards in place to protect the physical and psychological health of the participants in light of the risks/stresses identified in D1.

Each trial is to last no more than one (1) hour and each training session is to last no more than three (3) hours. Participants will be given breaks in between each trial or training session (see B2) and are free to end the study at any point. Investigators will emphasise that the purpose of the study is to assess the design of the Human-Machine Interfaces (HMI) and not the expertise of the operators in order to minimize the risk described in D1.

E. INFORMED CONSENT PROCESS

Refer to requirements for content under Elements for Information Letters and Consent Forms, including suggested wording:

<http://www.research.uwaterloo.ca/ethics/human/samples/ElementsInfoLtrConsentForm1.htm>

1. What process will be used to inform the potential participants about the study details and to obtain their consent for participation?

- Information letter with written consent form; provide a copy
 Information letter with verbal consent; provide a copy
 Information/cover letter; provide a copy

Other (specify):

Please see Appendix I.G.

2. If written consent cannot be obtained from the potential participants, provide a justification.

N/A

3. Does this study involve persons who cannot give their own consent (e.g. minors)?
Yes No

If **Yes**, provide a copy of the Information Letter and Permission Form to be used to obtain permission from those with legal authority to give it.

F. ANONYMITY OF PARTICIPANTS AND CONFIDENTIALITY OF DATA

1. Explain the procedures to be used to ensure anonymity of participants and confidentiality of data both during the research and in the release of the findings.

All participants will be assigned a non-descriptive alias, which will be used on personal information, performance data, and interview documents. Aliases will not be made available to other participants or to the participants' employers. Data will be combined and analysed in such a way that participants are not identified in the results.

For audio and video recordings, a stationary camera will be placed behind each participant such that the participant's face will be shielded. Head mounted cameras will also be used, which make it possible for other participants to be recorded. However, the intention of the audio and video recordings is to capture the participant's interaction with the Human-Machine Interface (HMI). All participants will be identified only by their alias in the recordings.

It should be noted that the audio and video recordings will be used in conjunction with other data collected throughout the experiment at the HRP and participating institutions. All participants will have the right to view their own data. All information provided by the participants will be considered confidential. Data will only be used for the purpose of the experiment described above and for no other purposes. Results of the study will be presented in internal HRP publications and international scientific journals such that participants cannot be identified in any way.

2. Describe the procedures for securing written records, questionnaires, video/audio tapes and electronic data, etc.

See Appendix I.D.

3. Indicate how long the data will be securely stored, the storage location, and the method to be used for final disposition of the data.

- Paper Records
 - Confidential shredding after _____ years
- Data will be retained indefinitely in a secure location
- Audio/Video Recordings
 - Erasing of audio/video tapes after _____ years
- Data will be retained indefinitely in a secure location
- Electronic Data
 - Erasing of electronic data after _____ years
- Data will be retained indefinitely in a secure location
- Other (provide details on type, retention period and final disposition, if applicable):

Specify storage location: See Appendix I.D.

4. Are there conditions under which anonymity of participants or confidentiality of data cannot be guaranteed? Yes No

If Yes, please provide details:

G. DECEPTION

Will this study involve the use of deception? Yes [] No [X]

If **Yes**, describe the deception(s) to be used in this study **AND** provide a justification for its use.

If **Yes**, outline the process to be used to debrief participants. Attach a copy of the written debriefing sheet and the materials used to obtain consent following debriefing.

Researchers must ensure that all supporting materials/documentation for their applications are submitted with the signed, hard copies of the ORE form 101/101A. Note that materials shown below in bold are normally required as part of the ORE application package. The inclusion of other materials depends on the specific type of projects.

* Researchers are advised to review the Sample Materials section of the ORE web site: http://www.research.uwaterloo.ca/ethics/human/informed_consent.asp

Please **check** below all appendices that are attached as part of your application package:

- [] **Recruitment Materials:** A copy of any poster(s), flyer(s), advertisement(s), letter(s), telephone or other verbal script(s) used to recruit/gain access to participants.
- [X] **Information Letter and Consent Form(s)*.** Used in studies involving interaction with participants (e.g. interviews, testing, etc.)
- [] **Information/Cover Letter(s)*.** Used in studies involving surveys or questionnaires.
- [] Parent Information Letter and Permission Form*. For studies involving minors.
- [] Medical Screening Form: Must be included for **all** physiological measurements involving greater than minimal risk and tailored for each study.
- [X] **Materials:** A copy of all survey(s), questionnaire(s), interview questions, interview themes/sample questions for open-ended interviews, focus group questions, or any standardized tests used to collect data.
- [] **Feedback letter ***
- [] Debriefing Letter: Required for all studies involving deception.
- [] Post-Debriefing Consent Form. Required for all studies involving deception.
- [X] Ethics Approval Certificate from other institution's Research Ethics Board. A copy is required for multi-centred research.
- [] ORE Form 102: To be submitted by applicants who wish access to students and/or teachers from the local school boards.
- [] Research Proposal: A copy should be appended for faculty, undergraduate or graduate research if available.
- [] Other:

NOTE: The submission of incomplete application packages will increase the duration of the ethics review process.

To avoid common errors/omissions, and to minimize the potential for required revisions, applicants should ensure that their application and attachments are consistent with the *Checklist For Ethics Review of Human Research Application*

<http://www.research.uwaterloo.ca/ethics/form101/checklist.asp>

Remember to print and sign the application and forward TWO copies of the application with all supporting materials to the Office of Research Ethics, NH 1024.

NOTE: The study may not begin until written notice of full ethics clearance has been received from the Office of Research Ethics.

--

INVESTIGATORS' AGREEMENT

I have read the Office of Research Ethics **Guidelines for Research with Human Participants** and agree to comply with the conditions outlined in the **Guidelines**. In the case of student research, as Faculty Supervisor, my signature indicates that I have read and approved the application and proposal, deem the project to be valid and worthwhile, and agree to provide the necessary supervision of the student.

Signature of Faculty Investigator

Date

Signature of Faculty Investigator/Supervisor

Date

Signature of Student Investigator

Date

Signature of Student Investigator

Date

FOR OFFICE OF RESEARCH ETHICS USE ONLY:

Susan E. Sykes, Ph.D., C. Psych.

Director, Office of Research Ethics

Or

Susanne Santi, M.Math.

Manager, Research Ethics

Date

Copyright © 2000-2002 Office of Research Ethics, University of Waterloo

Appendix I.A: Informed Consent/QA-F-202: Consent for participation in study of the Halden Reactor Project

 Institutt for energiteknikk OECD HALDEN REACTOR PROJECT	Page 1 of 5
--	-------------

Title Consent for participation in study of the Halden Reactor Project	
:	
Data file reference : exps\general\qa	Document ID : QA-F-202
No. of Enclosures : 1	Confidential grade : HRP Only
Issue No. : 3	Date : 2004-09-03

Purpose Ensure that all human participants in the experiments are well informed about the study they will participate in, and that they are informed about the rights and responsibility of each party during the experiment.

References QA-P-271 Human Participants Protection Procedure

Enclosure Consent for participation in study at the Halden Reactor Project (in English, Swedish and Norwegian)

	Name	Signature	Date
Prepared by :	Magnhild Kaarstad/ Gyrd Skraaning jr.		
Checked by :	Ann Britt Skjerve, Per Øivind Braarud		
Approved by :	Andreas Bye		



CONSENT FORM

HAMMLAB-EXPERIMENT	
DATE(S) FOR PARTICIPATION	

I I have received information concerning

- The purpose of the study and my role in the experiment.
- Procedures, equipment, and questionnaires/tests that will be used during the experiment.

II I know that

- All information obtained about me during the study will be treated confidentially, and stored safely.
- Video film with sound from the simulator control room will be recorded.
- I have the right to examine my own data.
- Collected data may be used for research purposes at HRP.
- The objective of the experiment is not to study the performance of identified, individual people, and the data gathered will not be stored or used in this way in future examination of the data.
- Experimental results will be reported in internal HRP-publications and international scientific journals.
- I have the right to withdraw from the study at any point, and without consequences, due to health, safety, private or other concerns.
- I am free to withdraw from the experiment immediately and refuse to sign this consent form without giving any reason for this.

III I volunteer to participate in the experiment

Place / date:.....

Name in block-letters:.....

Signature:.....

Experimenter:

Set a cross (X) in the box if the operator withdraws from the experiment

Suggest possible causes for the operator's decision:

SAMTYKKE-FORMULAR

HAMMLAB-EKSPERIMENT	
DATO(ER) FOR DELTAGELSE	

I Jeg er blitt informert om

- Studiets hensikt og min rolle i eksperimentet
- Prosedyrer, utstyr og spørreskjema/tester som benyttes under eksperimentet

II Jeg kjenner til at

- Alle opplysninger og all informasjon om meg som registreres under eksperimentet blir behandlet konfidensielt og oppbevares på en sikker måte
- Det blir tatt opp videofilm med lyd fra kontrollrommet
- Jeg har innsynsrett i egne data
- Alle data som samles inn under eksperimentet kan benyttes i forskningsøyemed ved HRP
- Studiets hensikt ikke er å undersøke individuelle prestasjoner utført av identifiserbare personer, og at innsamlede data heller ikke vil bli lagret eller anvendt på en slik måte i fremtidige dataanalyser
- Eksperimentelle resultater rapporteres i interne HRP-publikasjoner og vitenskapelige tidsskrifter
- Jeg har rett til å trekke meg fra eksperimentet av helsemessige, sikkerhetsmessige, private eller andre årsaker, når jeg måtte ønske det, og uten at dette får noen konsekvenser
- Jeg kan la være å skrive under dette samtykke-formularet og trekke meg ifra eksperimentet nå, uten å gi noen begrunnelse for dette

III Jeg deltar frivillig i eksperimentet

Sted / dato:.....

Navn (blokkbokstaver):.....

Signatur:.....

<p><u>Eksperimentator:</u></p> <p>Sett et kryss i ruten dersom operatøren velger å trekke seg fra eksperimentet <input type="checkbox"/></p> <p>Redegjør for mulige årsaker til at operatøren trekker seg her:</p>

SAMTYCKE-FORMULÄR

HAMMLAB-EXPERIMENT	
DATON(N) FÖR DELTAGANDE	

I Jag har blivit informerad om

- Avsikten med studien och min roll i experimentet
- Tillvägagångssätt, utrustning och frågeschema/tester som utnyttjas under experimentet

II Jag känner till att

- Alla upplysningar och all information om mig som registreras under experimentet blir behandlat konfidentiellt och förvaras säkert
- Det blir videofilmad med ljud från kontrollrummet
- Jag har insynsrätt i egna data
- All data som samlas in under experimentet kan utnyttjas i forskningssyfte vid HRP
- Studiens avsikt är inte att undersöka individuella prestationer utförda av identifierbara personer, och all insamlad data vill heller inte bli lagrad eller använd på et sådant sätt i framtidiga dataanalyser
- Experimentella resultat rapporteras i interna HRP-publikationer och vetenskapliga magasin
- Jag har rätt att dra mig från experimentet av hälsomässiga, säkerhetsmässiga, privata eller andra orsaker, när jag vill, och utan att detta får några konsekvenser
- Jag kan låta bli att signera detta samtycke-formuläret och dra mig från detta experimentet nu, utan att ge någon begrundning för detta

III Jag deltar frivilligt i experimentet

Plats / datum:.....

Namn (blockbokstäver):.....

Signatur:.....

<p><u>Eksperimentator:</u></p> <p>Sett et kryss i ruten dersom operatøren velger å trekke seg fra eksperimentet <input type="checkbox"/></p> <p>Redegjør for mulige årsaker til at operatøren trekker seg her:</p>

SUOSTUMUS OSALLISTUA HALDEN REACTOR PROJECTIN TUTKIMUKSEEN

HAMMLAB koe: **EXP-01**

Osallistumispäivä/päivät: _____

I Olen saanut seuraavat tiedot ennen tutkimusta:

- yleiskuva omasta osuudestani kokeen aikana.
- kuvauksen kokeessa käytettävistä ohjeista.

II Minua on informoitu:

- että, tutkimuksen aikana kaikkia minuun liittyviä tietoja tullaan käsittelemään luottamuksellisesti.
- että, kaikkia minua koskevia tutkimuksen aikana kerättäviä tietoja voidaan käyttää tutkimustarkoituksiin kuuden vuoden ajan (2 HRP-periodia), minkä jälkeen kaikki tiedot hävitetään.
- että kokeet kuvataan videolla ja että silmien liikkeet kokeen aikana tallennetaan.
- että tulokset julkaistaan sisäisissä raporteissa (HWR) ja tieteellisissä aikakauslehdissä.
- että, minulla on oikeus nähdä minua koskevat tiedot.
- että, minulla on oikeus vetäytyä tutkimuksesta ilman seuraamuksia terveyden, turvallisuuden tai yksityisasioiden takia.
- että voin olla allekirjoittamatta suostumuslomaketta ja että voin vetäytyä kokeesta ilman perustelua (*mikäli operaattori päättää vetäytyä kokeesta, merkitse rasti tähän ja selvitä mahdollisia syitä arkin toisella puolella*).

Minua on informoitu ja ymmärrän mikä on osuuteni tässä tutkimuksessa ja osallistun vapaaehtoisesti tutkimukseen.

Paikka / Aika : _____

Nimi painokirjaimin: _____

Allekirjoitus: _____

Appendix I.B: Demographics Questionnaire



DEMOGRAPHIC QUESTIONNAIRE

HAMMLAB-EXPERIMENT	
DATE(S) FOR PARTICIPATION	

Alias Identifier: _____

Role in this Experiment:

- Turbine operator:
- Reactor operator:
- Shift supervisor:

Personal Information

2. Age: _____ yrs.
3. Gender: Male _____ Female _____
4. Workplace: Forsmark3 _____ Oskarshamn3 _____

Formal Education

5. Describe your formal education?

6. Which licences do you currently have?
 - Turbine operator:
 - Reactor operator:
 - Shift supervisor:

7. How many years have you worked in the following positions:
 - Turbine operator: _____ yrs
 - Reactor operator: _____ yrs
 - Shift supervisor: _____ yrs

8. How many years have you worked in the following positions of nuclear power plants
 - Electrical maintenance: _____ yrs
 - Instrument maintenance: _____ yrs
 - Mechanical maintenance: _____ yrs
 - Instructor: _____ yrs
 - Field operator: _____ yrs
 - Shift Engineer: _____ yrs



9. What is your main/current position in your nuclear power plant? (Checked all that applies.)

- Turbine operator:
- Reactor operator:
- Shift supervisor:
- Electrical maintenance:
- Instrument maintenance:
- Mechanical maintenance:
- Instructor:
- Field operator:
- Shift engineer:

HAMMLAB & Experiment Experience

10. Which of the following years have you participated in HAMMLAB experiments? (Checked all that applies.)

- | | | | |
|--------|--------------------------|--------|--------------------------|
| • 1995 | <input type="checkbox"/> | • 1996 | <input type="checkbox"/> |
| • 1997 | <input type="checkbox"/> | • 1998 | <input type="checkbox"/> |
| • 1999 | <input type="checkbox"/> | • 2000 | <input type="checkbox"/> |
| • 2001 | <input type="checkbox"/> | • 2002 | <input type="checkbox"/> |
| • 2003 | <input type="checkbox"/> | • 2004 | <input type="checkbox"/> |
| • 2005 | <input type="checkbox"/> | | |

11. During the last 12 months, how many shifts have you been working in the same role as you will have in the experiments in HAMMLAB?

- Less than 30 shifts:
- Between 30 and 100 shifts:
- More than 100 shifts:

12. Have you been part of any experiment(s) not associated with HAMMLAB?

- Yes: Total participation time: _____ days
- No:

13. What is your attitude towards being part of experiments?

Negative 2 3 4 5 6 7 Positive

Operator Characteristics

14. In general, how would you characterise yourself in the operational situation?

Introvert 2 3 4 5 6 7 Extrovert



15. In general, to what extent do you plan ahead versus respond to the needs of operational situation as they occur?

Always respond to the needs as they occur
1 2 3 4 5 6 7
Always plan ahead

16. In general, do you consider your job to have more negative or positive elements?

Negative
1 2 3 4 5 6 7
Positive

17. Please indicate how you expect the answer the previous question in 1 year from now?

Negative
1 2 3 4 5 6 7
Positive

Computer experience

18. Please indicate how you expect the answer the previous question in 1 year from now?

Not familiar
1 2 3 4 5 6 7
Very familiar

19. How familiar are you with using the computer-mouse?

Not familiar
1 2 3 4 5 6 7
Very familiar

20. How often do you use computers at work?

- Several hours each day:
- A few hours each day:
- A few hours each week:
- A few hours each month:
- Never:

21. How often do you use computers at home?

- Several hours each day:
- A few hours each day:
- A few hours each week:
- A few hours each month:
- Very rare/Never:



Colleagues

30. It is common that operators support each other's performance?

Never
1 2 3 4 5 6 Always
7

31. In general, to what extent do you see your colleagues as competent?

Not at all
1 2 3 4 5 6 Extremely
competent
7

32. To what extent are there differences among your colleagues?

No variation
1 2 3 4 5 6 An extreme degree
of variation
7

33. In general, what is the balance between the help you get and the help you give to colleagues?

I give more
help
1 2 3 About the
same
4 5 6 I get more
help
7

34. To what extent does management encourage operators to help and support each other's work?

No
encouragement
1 2 3 4 5 6 Strong
encouragement
7

35. How much have you been working together in your team?

Not much
1 2 3 4 5 6 A lot
7

36. How would you characterise yourself as a team?

We typically work
on our own
1 2 3 4 5 6 We typically work
very closely together
7

37. How would you characterise the importance of teamwork when performing the 314 procedure?

Not important
1 2 3 4 5 6 Very important
7



38. How would you characterise the importance of teamwork when performing the 354 procedure?

Not important 1 2 3 4 5 6 Very important 7

39. How would you characterise the importance of teamwork when performing the 3020 procedure?

Not important 1 2 3 4 5 6 Very important 7

40. In general, to what extent do you as a team plan ahead – versus – respond to needs of the situation as they occur?

As they occur 1 2 3 4 5 6 Plan ahead 7

Operator Opinions

41. In case of operator incorrectly - as judged by management afterwards - disconnects automation, what is the likelihood that the operator will be sanctioned?

a) In situations where the 'error' did not cause any major disturbances:

The operators will always be sanctioned 1 2 3 4 5 6 The operators will never be sanctioned 7

b) In situations where the 'error' caused major disturbances:

The operators will always be sanctioned 1 2 3 4 5 6 The operators will never be sanctioned 7

42. When everything progresses as planned, how would you characterise the allocation of tasks between operators and automation?

Allocation is inadequate 1 2 3 4 5 6 Allocation is adequate 7



43. During the last year, to what extent have you found the allocation of tasks between operators and automation to be adequate?

Allocation is never adequate							Allocation is always adequate
1	2	3	4	5	6		7

Automation

44. In general, to what extent are the activities of the automatic system understandable to you?

They are never easy to understand							They are always easy to understand
1	2	3	4	5	6		7

45. During the last year, how many times have you been truly surprised by the activity performed by the automatic system? _____ times

46. In general, to what extent are you satisfied with the information you can obtain from the human-machine interface about activities of the automatic system (in Forsmark)?

Not at all							Completely
1	2	3	4	5	6		7

47. In general, to what extent do you understand the basis workings of the automatic system?

Not at all							Completely
1	2	3	4	5	6		7

48. What is your attitude towards increased automation in general?

Want less			Stay the same			Want more
1	2	3	4	5	6	7

Please describe why: _____

49. What is your attitude towards increased automation of procedures?

Want less			Stay the same			Want more
1	2	3	4	5	6	7

Please describe why: _____



Production & Safety

50. How would you describe your management's policy with regard to preserving the safety in your plant?

Not prioritized
1 2 3 4 5 6 Very highly prioritized
7

51. How would you describe your management's policy with regard to maintaining the production in your plant?

Not prioritized
1 2 3 4 5 6 Very highly prioritized
7

52. How important is it for you that you preserve safety in your plant?

Not important
1 2 3 4 5 6 Very important
7

53. How important is it for you that you maintain the production in your plant?

Not important
1 2 3 4 5 6 Very important
7

54. How often have you experienced a conflict between operating the process safely and maintaining the production?

Never
1 2 3 4 5 6 Very often
7

55. If you answered between 2 and 7 for the previous question, in what process conditions have you experienced this conflict most often? (Checked all that applies.)

- Normal operations:
- Start up:
- Ordinary disturbance:
- Emergency disturbance:
- Maintenance during operation:
- Outages:
- Planned shut down:
- Unplanned shut down:
- Other:

56. How often have you experienced that the management's expectations differ from your own judgement of what will be the best solution in a particular situation?

Never
1 2 3 4 5 6 Very often
7



57. If you answered between 2 and 7 for the previous question, in what process conditions have you experienced this conflict most often? (Checked all that applies.)

- Normal operations:
- Start up:
- Ordinary disturbance:
- Emergency disturbance:
- Maintenance during operation:
- Outages:
- Planned shut down:
- Unplanned shut down:
- Other:

Scenario experience

58. How familiar are you with the 314 (pressure relief) system?

Not familiar							Very familiar
1	2	3	4	5	6		7

59. How complex do you think the 314 (pressure relief) system is?

Very simple							Very complex
1	2	3	4	5	6		7

60. How often have you performed periodic tests on the 314 system (in training or in work)?

Never							A lot of times
1	2	3	4	5	6		7

61. How familiar are you with the 354 (control rod) system?

Not familiar							Very familiar
1	2	3	4	5	6		7

62. How complex do you think the 354 (control rod) system is?

Very simple							Very complex
1	2	3	4	5	6		7

63. How often have you performed periodic tests on 354 system (in training or in work)?

Seldom							Very often
1	2	3	4	5	6		7

64. How familiar are you with the 3020 (shutdown) procedure?

Not familiar							Very familiar
1	2	3	4	5	6		7



65. How complex do you think the 3020 procedure is to perform?

Very simple
1 2 3 4 5 6 Very complex
7

66. How often have you performed the 3020 procedure (in training or in work)?

Never
1 2 3 4 5 6 A lot of times
7

67. How would you categorise your own skill level regarding the above procedures/systems?

Not very skilled
1 2 3 4 5 6 Very skilled
7

68. In general, when performing the procedures above, to what extent do you worry about something going wrong?

Do not worry
1 2 3 4 5 6 Worry all the time
7

69. In general, do you find the above procedures stressful to perform?

Very stressful
1 2 3 4 5 6 Not at all stressful
7

Appendix I.C: Task Complexity Questionnaire

	Institutt for energiteknikk OECD HALDEN REACTOR PROJECT	Page 1 of 1
---	--	-------------

TASK COMPLEXITY QUESTIONNAIRE

HAMMLAB-EXPERIMENT	
DATE(S) FOR PARTICIPATION	

Instruction:

Please evaluate the current scenario by placing a mark on the rating scale for each question below. The rating scale ranges from very difficult (1) to easy (7) with medium difficulty (4) in the middle position. When using the rating scale, compare the current scenario with your experience so that:

1 = this scenario was comparable to some of the most difficult scenarios you have experienced

4 = this scenario was comparable to intermediate difficult scenarios

7 = this scenario was comparable to some of the easiest scenarios you have experienced

1. Unclear or ambiguous process picture, misleading or missing process indication:

Very difficult			Intermediate			Easy
1	2	3	4	5	6	7

2. Ambiguous, misleading or missing process feedback on process actions:

Very difficult			Intermediate			Easy
1	2	3	4	5	6	7

3. Sufficient time available to plan and very difficult:

Very difficult			Intermediate			Easy
1	2	3	4	5	6	7

4. Many simultaneous tasks (several disturbances, several process occurrences) making the individual tasks difficult to perform:

Very difficult			Intermediate			Easy
1	2	3	4	5	6	7

5. Collecting and using large amount of information required to do the work:

Very difficult			Intermediate			Easy
1	2	3	4	5	6	7

Appendix I.D: Table for management of experimental data in HAMMLAB

	Institutt for energiteknikk OECD HALDEN REACTOR PROJECT	Page 1 of 3
---	--	-------------

Title : Table for management of experimental data in HAMMLAB	
Data file reference : \exps\general\qa	Document ID : QA-P-272
No. of Enclosures : 1	Confidential grade : HRP Only
Issue No. : 1	Date : 1998-04-15

Purpose Ensure consistent management of experimental data by specifying storage, access and backup procedures for different data types.

Scope The data management system is valid for all Joint Programme and bilateral experiments performed in HAMMLAB.

Responsibility The principal investigator for each study is responsible for applying the data management system.

Enclosure Table for management of experimental data, constituting the data management system.

Date	Name	Signature
Prepared by :	Asgeir Drøivoldsmo/Gyrd Skraaning jr.	
Checked by :	Mark Green	
Approved by :	Kjell Haugset	



Document ID: QA-P-272	Issue No.: 1	Confidential grade : HRP Only	Page 2 of 3
-----------------------	--------------	-------------------------------	-------------

Table for management of experimental data

Data category	Example of data type	Primary storage (master copy)	Access	Backup storage	Access	Backup procedure
Audio/Video data	Eye movement videos	Locked file cabinet	2	Locked file cabinet, different building	1	Direct recording of backup tape for each experimental run.
Computer logs and trends	Overview videos	Locked file cabinet	2	Locked file cabinet, different building	1	Direct recording of backup tape. (optional)
	Variable logs	Restricted admission disk area	2	IFE tape storage	2	General IFE backup system + CD-ROM after experiment data collection
	Experiment logs	Restricted admission disk area	2	IFE tape storage	2	General IFE backup system + CD-ROM after experiment data collection
	Trend curves	Restricted admission disk area	2	IFE tape storage	2	General IFE backup system + CD-ROM after experiment data collection
Paper data	Questionnaires	Locked file cabinet	1	Locked file cabinet, different building	1	Daily during experiments
	Tests	Locked file cabinet	1	Locked file cabinet, different building	1	Daily during experiments
	Interviews	Locked file cabinet	1	Locked file cabinet, different building	1	Daily during experiments
Analysis files and reports.	Data matrices	Restricted admission disk area	2	IFE tape storage	2	General IFE backup, CD-ROM after experiment data analysis
	Data analyses files	Restricted admission disk area	2	IFE tape storage	2	General IFE backup, CD-ROM after experiment data analysis
	Plans and experimental keys	Restricted intranet server, restricted admission disk area	2	IFE tape storage	3	General IFE backup, CD-ROM after data collection.

Document ID: QA-P-272	Issue No.: 1	Confidential grade : HRP Only	Page 3 of 3
-----------------------	--------------	-------------------------------	-------------

DATA ACCESS CODES

1. Responsible person from experimental support.
2. People from the MMI section working with the actual experiment.
3. Other people involved in the experimental activities.
4. All users connected to the HRP internal data system.

When restoring data from backup, the principal investigator controls data access codes.

Document ID: QA-P-271	Issue No.: 2	Confidential grade : HRP Only	Page 2 of 5
-----------------------	--------------	-------------------------------	-------------

Human Studies Review Committee

General

Each research experiment, study, or testing of products that involve human participants must first be approved by the HRP Human Studies Review Committee. This Committee is appointed by the Project Manager of the HRP or his designee. The task of the HSRC is to evaluate the risks, benefits, and safeguards to the subjects health, safety, and right to privacy. The HSRC shall be guided by the principles set forth in this document.

The HSRC shall be composed of three (3) members with alternates designated for each, to ensure that the evaluation can be undertaken by persons independent of the study in question. The Committee shall have the authority to terminate or suspend ongoing research if it determines that such action is necessary to protect human participants.

Review Procedure

The Committee shall particularly review the following:

1. Appropriateness of the staff expertise and organisational resources for the proposed research activity.
2. Availability of adequate facilities for the proposed research.
3. Assurance that the participating staff has the qualification necessary for use of equipment and methods with significance for the human participants in the experiment.
4. Methods and equipment are used according to HRP ethical standards.
5. Participants have all necessary information for giving their informed consent (QA-F-202) to participate in the study, and that every participant gives an informed consent.
6. Decisions and requirements for modification will be conveyed to the principal investigator in writing.

The Principal Investigator's Responsibilities

The principal investigator is responsible for the ethical practice of all involved staff, collaborators, and assistants that take part in the study. The principal investigator (e.g. project leader) shall report the planned study to the Committee well before the study is to be done. The report should include:

- Appropriateness of the staff expertise and organisational resources for the proposed research activities.
- Assurance that the quality guidelines for equipment and methods involved in the study are satisfied.
- The procedure for getting informed consent from the participants in the study.
- Assurance that the duty to notify the Data Inspectorate in Norway (Datatilsynet) about the HAMMLAB studies is held,

Document ID: QA-P-271	Issue No.: 2	Confidential grade : HRP Only	Page 3 of 5
-----------------------	--------------	-------------------------------	-------------

"meldeplikt til Datatilsynet": Our studies require notification (meldeplikt), not duty to get official permission (konsesjonsplikt), since we deal with non-sensitive information. We have to send a new notification (melding) every third year. Check the date of the enclosed document, "bekreftelse på melding til Datatilsynet", in order to ensure that this matter is in order. If it will be older than three years during the time of the experiment, send new notification. See also the same enclosure to see how you can look at the notification itself, e.g., at <http://www.datatilsynet.no/oppslag/?vis=6742>

HRP Ethical Principles on Research Involving Human Participants

Research

Responsibilities Prior to conducting research, there should be entered an agreement with participants that clarifies the nature of the research and the responsibilities of each party.

Informed Consent to Research

The investigators inform participants of the nature of the research: they inform participants that they are free to participate or to decline to participate or to withdraw from the research, they explain the foreseeable consequences of declining or withdrawing ; they inform participants of significant factors that may be expected to influence their willingness to participate (such as risks, discomfort, adverse effects, or limitations on confidentiality); and they explain other aspects about which the prospective participants inquire.

Informed Consent in Research Filming or Recording

Investigators obtain informed consent from research participants prior to filming or recording the participants in any form, unless the research involves simply naturalistic observations in public places and it is not anticipated that the recording will be used in a manner that could cause personal identification or harm.

Sharing and Utilising Data

Investigators inform research participants of their anticipated sharing or further use of personally identifiable research data and of the possibility of unanticipated future uses.

Providing Participants With Information About the Study

Investigators provide a prompt opportunity for participants to obtain appropriate information about the nature, results, and conclusions of the research, and investigators attempt to correct any misconceptions that participants may have. If scientific or human values justify delaying or withholding this information, investigators take responsible measures to reduce the risk of harm.

Confidentiality

Information obtained about the research participants during the study is confidential. The participants identified shall not be revealed in the reports from the study.

Document ID: QA-P-271	Issue No.: 2	Confidential grade : HRP Only	Page 5 of 5
-----------------------	--------------	-------------------------------	-------------

From: Andreas Bye <Andreas.Bye@hrp.no>
To: postmester@hetti.datatilsynet.no
Subject: Vennligst bekreft melding til Datatilsynet: (#AIVZ0WbuLW5yKxRB#)
Date: Tue, 3 Dec 2002 11:43:07 +0100 (MET)

At 10:27 -0000, , 3 December 2002,
postmester@hetti.datatilsynet.no wrote:

| _____
| VENNLI GST BEKREFT MELDING TIL DATATILSYNET
|
| Datatilsynet mottok 03.12.2002 en melding med meldingsnummer: 6742
| med referanse til denne e-postadressen.
| Behandlingsansvarlig virksomhet er oppgitt til: Institutt for energiteknikk
|
| MELDINGEN MÅ BEKREFTES ELLER AVKREFTES
| DERSOM MELDINGEN IKKE BEKREFTES, BLIR DEN IKKE REGISTRERT
HOS DATATILSYNET
|
| Virksomheten må bekrefte meldingen. Det gjør du ved å returnere
| e-posten. Bruk svar-funksjonen til e-postleseren. Ikke endre noe i
| emnefeltet. Dersom meldingen er kommet til din e-postadresse ved en
| feil, ber vi deg avkrefte meldingen. Dette gjør du ved å returnere
| e-postmeldingen og skrive ordet 'avkreft' på første linje i
| svarbrevet. Ikke endre emnefeltet i dette tilfellet heller.
| _____
| MOTTATT MELDING I HENHOLD TIL PERSONOPPLYSNINGSLOVEN § 31
|
| MELDINGEN INNEBÆRER IKKE EN GODKJENNELSE
| Vi gjør oppmerksom på dette bare er en bekreftelse på at Datatilsynet
| har mottatt meldingen. Datatilsynet har ikke vurdert om behandlingen
| av personopplysninger tilfredsstill er kravene i
| personopplysningsloven. Den behandlingsansvarlige er selv ansvarlig
| for at disse kravene er oppfylt.
|
| NÅR KAN BEHANDLINGEN STARTE?
| Virksomheten kan sette i gang eller fortsette den meldte behandlingen
| når den har bekreftet denne e-postmeldingen.
|
| NY MELDING / ENDRINGSMELDING
| Datatilsynet gjør oppmerksom på at den behandlingsansvarlige må sende
| ny melding etter tre år, eller dersom behandlingen endres slik at den
| går ut over rammene til behandlingen som allerede er meldt. Ordlyden i
| bestemmelsen er som følger:
|
| "Ny melding må gis før behandling som går ut over den rammen for
| behandling som er angitt i medhold av § 32. Selv om det ikke har
| skjedd endringer, skal det gis ny melding tre år etter at forrige
| melding ble gitt." (Personopplysningsloven § 31 tredje ledd)
|
| Innholdet i meldingen skal være offentlig, i overensstemmelse med
| lovens krav. (Personopplysningsloven § 42 annet ledd nr 1.)
| Datatilsynet legger meldingene i en offentlig tilgjengelig
| database. Din melding finnes da på denne adressen:
| <http://www.datatilsynet.no/oppslag/?vis=6742>

Appendix I.F: University of Toronto Ethics Approval Certificate



UNIVERSITY OF TORONTO

Office of the Vice-President, Research and Associate Provost

Ethics Review Office

PROTOCOL REFERENCE #15870

November 10, 2005

Prof. G.A. Jamieson
Mechanical and Industrial Engineering
5 King's College Circle
Toronto, ON M5S 3G8

Mr. Nathan Lau
Mechanical and Industrial Engineering
5 King's College Circle
Toronto, ON M5S 3G8

Dear Prof. Jamieson and Mr. Lau:

Re: Your research protocol entitled "Prototyping and Evaluation of Ecological Interfaces in a Nuclear Power Plant"

ETHICS APPROVAL

Original Approval Date: November 10, 2005
Expiry Date: November 9, 2006

We are writing to advise you that a member of the Social Sciences and Humanities Research Ethics Board has granted approval to the above-named research study, for a period of **one year**, under the REB's expedited review process. Ongoing projects must be renewed prior to the expiry date.

The following consent documents (received November 7, 2005) have been approved for use in this study: Consent Form. Participants should receive a copy of their consent form.

During the course of the research, any significant deviations from the approved protocol (**that is, any deviation which would lead to an increase in risk or a decrease in benefit to participants**) and/or any unanticipated developments within the research should be brought to the attention of the Ethics Review Office.

Best wishes for the successful completion of your project.

Yours sincerely,

A handwritten signature in black ink, appearing to read 'Jenny Peto'.

Jenny Peto
Ethics Review Coordinator

xc: Ms. C. Kwan (Awards Administrator, Natural Sciences and Engineering)

**Full Ethics Clearance after provisional, no comments (ORE # 12691)
Tue, Dec 13, 2005 at 4:09 PM**

ORE Ethics Application System <OHRAC@uwaterloo.ca>
To: jamieson@mie.utoronto.ca, c4burns@engmail.uwaterloo.ca
Cc: j2kwok@engmail.uwaterloo.ca

Dear Researcher:

The recommended revisions/additional information requested in the initial ethics review of your ORE application:

Title: Halden Reactor Project
ORE #: 12691
Collaborator: Greg Jamieson (jamieson@mie.utoronto.ca)
Faculty Supervisor: Catherine M. Burns (c4burns@engmail.uwaterloo.ca)
Student Investigator: Jordanna Kwok (j2kwok@engmail.uwaterloo.ca)

have been reviewed and are considered acceptable. As a result, your application now has received full ethics clearance.

A signed copy of the Notification of Full Ethics Clearance will be sent to the Principal Investigator or Faculty Supervisor in the case of student research.

ADDITIONAL REVISIONS OR RESPONSES TO COMMENTS: N/A

Note 1: This clearance is valid for four years from the date shown on the certificate and a new application must be submitted for on-going projects continuing beyond four years.

Note 2: This project must be conducted according to the application description and revised materials for which ethics clearance have been granted. All subsequent modifications to the protocol must receive prior ethics clearance through our office and must not begin until notification has been received.

Note 3: Researchers must submit a Progress Report on Continuing Human Research Projects (ORE Form 105) annually for all ongoing research projects. In addition, researchers must submit a Form 105 at the conclusion of the project if it continues for less than a year.

Note 4: Any events related to the procedures used that adversely affect participants must be reported immediately to the ORE using ORE Form 106.

Best wishes for success with this study.

Susanne Santi, M. Math.,
Manager, Research Ethics
Office of Research Ethics
NH 1027
519.888.4567 x7163
ssanti@uwaterloo.ca

Appendix J

Experiment Materials

Abbreviated versions of the: (1) Self-Rated Bias Questionnaire, (2) HOPE Query Timelines and Probes, and (3) SACRI parameters, found in Skraaning , Nihlwing, Welch, & Veland (2005a) are included below for reference.

Self-Rated Bias Questionnaire

Part 1 - In this scenario period:

1. I had a good a overview of the process, 1 (Disagree) – 5 (Agree)
2. I made correct diagnoses, 1 (Disagree) – 5 (Agree)
3. I utilized the displays well, 1 (Disagree) – 5 (Agree)
4. I became aware of process deviations at an early stage, 1 (Disagree) – 5 (Agree)

Part 2 - In this scenario period:

1. I had a good a overview of the process, 1 (Disagree) – 5 (Agree)
2. I used my time efficiently, 1 (Disagree) – 5 (Agree)
3. I cooperated well with the rest of the shift team, 1 (Disagree) – 5 (Agree)
4. I made correct diagnoses, 1 (Disagree) – 5 (Agree)
5. My actions steered the process in the correct direction, 1 (Disagree) – 5 (Agree)
6. I utilized the displays well, 1 (Disagree) – 5 (Agree)
7. I became aware of process deviations at an early stage, 1 (Disagree) – 5 (Agree)
8. I performed the correct responses, 1 (Disagree) – 5 (Agree)

HOPE Query Timelines and Probes

Anticipated Scenario 1

No	Est. Time	Condition	Probes
1	~ 8 min	5 min after leakage initiated	<ul style="list-style-type: none">• Leakage from tube to shell in intermediate superheater, 422EA1

2	~ 10 min	Break Just before 313 PB2 pump stop	<ul style="list-style-type: none"> • Reduced temp on steam: temp diff 422KA504 and KB504 • Reduced drainage from, superheater: diff 422VA6 and VB6 • Increased drainage from LPH: Position of drainage valve 462VB29 increases • Increasing condensate flow to fw tank and increasing 462VA5 position
3	~ 18 min	1.30 min after alarm on diff	<ul style="list-style-type: none"> • Trip on one circulation pump • Send out FO • Reduce power to 90%, to restart pump • Handle leakage: decrease position of 421VA/B5 until temp diff 10 degrees
4	~ 40 min	End 7 min after 421 stuck	<ul style="list-style-type: none"> • Stuck steam valve to HP turbine • Halt power increase

Anticipated Scenario 2

No	Est. Time	Condition	Probes
1	~ 8 min	1.38 m Mf take effect at 220MW	<ul style="list-style-type: none"> • 463VA20, emergency drain valve does not open in HPH • Emergency drain valve 463VB19 does not open because of low power (<220 MW)
2	~ 10 min	Break Just before 1.72 m	<ul style="list-style-type: none"> • 423VB7 bleed valve cannot be closed because of mf; thus, level will increase and bypass cannot be prevented. • High level in HPH, 463K402 and auto bypass
3	~ 16 min	After VA5 closes	<ul style="list-style-type: none"> • Reset bypass when HPH level ok: VB7 does not open • Increase power and open 463VA20 • Increasing sea temp to pressure increasing in condenser • 462VA5 is closing and VB5 does not open; no flow to feedwater tank • TO has to regulate water level manually by controlling VB5 • Plant will trip because of low level in FW tank, if the operator does not succeed • RO: 314VB4 relief valve does not open and 314VA17 closed • RO: cooling water pump 713 PC1 trip
4	~ 24 min	End After VA4	<ul style="list-style-type: none"> • Min flow valve 463VA4 opens (FW pump PA1) • Reduced flow and decreasing reactor tank level

Anticipated Scenario 3

No	Est. Time	Condition	Probes
1	~ 4 min	1.57 in HPH (mf take effect at 440MW)	<ul style="list-style-type: none"> • HPH drain valve 463VB21 stuck 30% • Setpoint for 422VA10 regulating the level in 422TA2 is decreasing
2	~ 7 min	Break 1.70 in HPH or 0.74 in 422TA2	<ul style="list-style-type: none"> • Level in 422TA2 decreases
3	~ 15 min		<ul style="list-style-type: none"> • 422KA404, the measure regulating 422VA10 goes to max • 100% opening, high level alarm and 1/3 protection signal turbine • 422TA2 level will increase again and 422VA11 will regulate • Mf causes 463VA21 drain valve to close completely, bypass cannot be prevented

			<ul style="list-style-type: none"> Both problems (drifting measure and drain valve) should be reported and will be fixed Reset bypass, when FO completed Safe to continue running plant
4	~ 25 min	End After 441PD1 trip	<ul style="list-style-type: none"> RO: increasing temp in 722 and 321 pump trip Mf in 461VA6, 441PD1 seawater pump trips

Unanticipated Scenario 1

No	Est. Time	Condition	Probes
1	~ 6 min	2.78 in 422TB1	<ul style="list-style-type: none"> 422VB6 closing Water level 422TB1 increasing (normal level 2.5m) No alarm at 2.8m 422VB7 emergency valve does not open
2	~ 9 min	Break 3.15 in 422TB1 just before H2 (3.3m) and VB6 closes	
3	~ 15.30 min		<ul style="list-style-type: none"> Turbine trip One steam line remains open. 421VA1v1 Generator breaker will trip at 11MW
4	~ 20 min	End 10 min after 321 problem	<ul style="list-style-type: none"> Scram/maintenance/open generator breaker? RO: 422VB7, sprinkling valve starts to leak into drywell, flow from 322PB1 increasing and pressure and temperature decrease in drywell RO: 313pump speed increase and 321 PB1 trip

Unanticipated Scenario 2

No	Est. Time	Condition	Response
1	~ 5.40 min		<ul style="list-style-type: none"> Leak in KRA, increasing level in KRA building, decreasing level in condenser, changed position of positionen på 462VA5
2	~ 6.20 min	Break just before high level alarm in KRA	
3	~ 15 min	etter VA5 0.63 i rummet	<ul style="list-style-type: none"> RO: 313PC core cooling pump increased speed. RO should stop pump and report to FO Leakage in KRA increasing. Crews should decide to bypass The leakage will decrease but not completely: 332VB2 is stuck at 4%
4	~ 32 min	End	<ul style="list-style-type: none"> Low level alarm in condenser. 462VA5 closing, level in FW tank decreasing 462VB does not open and has to be controlled manually

Unanticipated Scenario 3

No	Est. Time	Condition	Response
1	~ 5 min	30% PB1	

2	~ 7 min	Break 10 sek. after pump trip. Before H2 (3.3m) and VB6 closes	<ul style="list-style-type: none"> • Seawater cooling pump decreases and trips • 461EA1.E2. Pressure in condenser increases • Flow will decrease and temp increase after PB1 pump • Seawater temp increases from 12 to 18C in five minutes • Increasing temp and pressure in condenser • RO has to reduce power
3	~ 18 min		<ul style="list-style-type: none"> • RO: 314 VC starts to leak • RO has to close 314VC6 and open VC5 • Pressure in condenser increase further and alarms from cooling system begins to get activated
4	~ 30 min	End 10 min after 321 problem	<ul style="list-style-type: none"> • Seawater temp increases to 25C • Bypass valve 4221VA3v1 opens due to mf • Condenser pressure increasing further. • The reactor will automatically decrease to 73%, if not already done by crew • RO: temp of cooling system increasing • Crew should shutdown the station; preferably manually

SACRI Parameters

Anticipated Scenario 1: After Detection Period

No	Item	Type
1	positionen på 422VA6	Specific
2	antalet i drift varande huvudkylvattenpumpar 441	Global
3	effekten, 613KA901	Specific
4	flödet från 462TD1	Specific
5	nivån i kondensorn 461KA40x	Global
6	temperaturen efter kondensatpumparna 462KA503	Global
7	ventilläget för 462VC19	Specific
8	nivån i 422TB1 422KB403	Global
9	temperaturen i gemensam ledning före HTFV, 463KB501	Global
10	trycket i kondensorn 461KA1xx	Global
11	positionen på ventil 462VA5	Specific
12	mavatempen efter HTFV 463KB507	Specific

Anticipated Scenario 1: After Mitigation Period

No	Item	Type
1	kondensatflödet 462KB301	Specific
2	trycket i kondensorn	Specific
3	turbinvarvtalet 452KA812	Global
4	positionen på 421VB1v1	Specific
5	positionen på 421VB2v1	Specific
6	temperaturen efter 422EA1 422KA504	Global
7	temperaturen i RI 583KX501	Specific RO
8	antalet stängda 421 ventiler	Global
9	effekten 613KA901	Global
10	tempdiffen mellan 422KA504 (efter 422EA1) och 422KB504 (efter EB1)	Specific
11	läget på 462VA/B35 (Dumptrum kylning)	Specific
12	antalet i drift varande mavapumpar 463PX1	Global

13	nivån i kondensorn 461KA40x	Global
14	trycket i reaktor tanken 211KW111	Global RO

Anticipated Scenario 2: After Detection Period

No	Item	Type
1	ventilläget för 462VC19	Specific
2	flödet från 462TD1 (462KD302)	Specific
3	positionen på 422VA6	Specific
4	nivån i 422TB1 422KB403	Global
5	antalet i drift varande huvudkylvattenpumpar 441	Global
6	kondensatflödet till mavatanken, 462KB301	Global
7	effekten 613KA901	Specific
8	turbinens lager vibrationer 403KA7xx	Global
9	temperaturen i gemensam ledning före HTFV, 463KB501	Global
10	positionen på ventil 462VA5	Specific
11	mavatempen efter HTFV 463KB507	Specific
12	antalet i drift varande kondensatpumpar 462Px1	Global

Anticipated Scenario 2: After Mitigation Period

No	Item	Type
1	vattennivån i 462TD1	Specific
2	antalet i drift varande HC-pumpar	Global RO
3	trycket i kondensorn	Specific
4	temperaturen i gemensam ledning före HTFV, 463KB501	Global
5	flödet till 341, 341KB301	Global
6	temperaturen efter kondensatpumparna 462KA503	Global
7	kondensatflödet till mavatanken, 462KB301	Global
8	effekten (613KC901)	Specific
9	antalet i drift varande kondensatpumpar 462Px1	Global
10	läget på 463VA4	Specific
11	flödet till 341 (341KB301)	Specific
12	kondensatflödet 462KB305	Specific
13	trycket i inneslutningen (583KC104)	Specific RO
14	trycket i kondensorn 461KA1xx	Global

Anticipated Scenario 3: After Detection Period

No	Item	Type
1	flödet från 462TD1 (462KD302)	Specific
2	nivån i MÖH dränagekäril 422TA2	Specific
3	nivån i kondensorn 461KA40x	Global
4	summa mavaföde 312KA031	Global
5	nivån i HTFV dränagekäril 463EA2	Specific
6	flödet till 341, 341KB301	Global
7	positionen på 463VA21	Specific
8	antalet stängda 421 ventiler	Global
9	positionen på nöddräneringsventil från HTFV EA1 463VB20	Specific
10	antalet i drift varande kondensatpumpar 462Px1	Global
11	positionen på nöddräneringsventilen från 422TA2, 422VA11	Specific

12	temperaturen på mava efter HTFV, 463KB507	Global
----	---	--------

Anticipated Scenario 3: After Mitigation Period

No	Item	Type
1	läget på Avsugningsventilen från 461EA1E1 441VA6	Specific
2	havsvattentemperaturen (441KA509)	Specific
3	flödet från 462TD1 (462KD302)	Specific
4	nivån i 422TB1 422KB403	Global
5	temperaturen efter 331EB2, EB3 (722KB503)	Specific RO
6	nivån i kondensorn 461KA40x	Global
7	antalet i drift varande huvudkylvattenpumpar 441	Global
8	temperaturen på 441KX511/512 (Temp. avg. kylv. srt. 1-6)	Specific
9	temperaturen efter HTFV (463KB507)	Specific
10	trycket i reaktor tanken 211KW111	Global RO
11	flödet till 341, 341KB301	Global
12	summa mavaflöde 312KA031	Global
13	kondensatflödet till mavatanken, 462KB301	Global
14	trycket i kondensorn (461KA105)	Specific

Unanticipated Scenario 1: After Detection Period

No	Item	Type
1	nivån i 422TB1	Specific
2	temperaturen på mava efter HTFV, 463KB507	Global
3	nivån i mavatanken 462KB402	Global
4	vattenflödet till 462TD1	Specific
5	antalet i drift varande kondensatpumpar 462Px1	Global
6	antalet stängda 421 ventiler	Global
7	flödet till 341, 341KB301	Global
8	flödet 341KB301?	Specific
9	antalet i drift varande huvudkylvattenpumpar 441	Global

Unanticipated Scenario 1: After Mitigation Period

No	Item	Type
1	varvtalet på turbinen, 452KA812	Specific
2	mavaflödet 463KB305	Specific
3	effekten 613KC901	Specific
4	trycket i kondensorn	Specific
5	antalet i drift varande huvudkylvattenpumpar 441	Global
6	effekten 613KA901	Global
7	positionen på 463VA4	Specific
8	turbinens lager vibrationer 403KA7xx	Global
9	turbinvarvtalet 452KA812	Global
10	temperaturen i gemensam ledning före HTFV, 463KB501	Global
11	temperaturen efter kondensatpumparna 462KA503	Global
12	reaktoreffekten 531KW077	Specific RO
13	antalet stängda ventiler i 321	Global RO
14	positionen på 462VA5	Specific

Unanticipated Scenario 2: After Detection Period

No	Item	Type
1	vattenflödet från kondensorn	Specific
2	vattenflödet till mavatanken	Specific
3	flödet till 341, 341KB301	Global
4	positionen på 462VA5	Specific
5	turbinvarvtalet 452KA812	Global
6	antalet i drift varande kondensatpumpar 462Px 1	Global
7	antalet stängda 421 ventiler	Global
8	temperaturen efter kondensatpumparna 462KA503	Global
9	kondensatflödet till mavatanken, 462KB301	Global

Unanticipated Scenario 2: After Mitigation Period

No	Item	Type
1	temperaturen efter kondensatpumparna 462KA503	Global
2	nivån i kondensorn	Specific
3	antalet i drift varande kondensatpumpar 462Px 1	Global
4	antalet i drift varande huvudkylvattenpumpar 441	Global
5	HC flödet	Specific RO
6	trycket i kondensorn	Specific
7	antalet 721 pumpar i drift	Global RO
8	flödet till 341, 341KB301	Global
9	positionen på 462VA5	Specific
10	kondensatflödet 462KB301	Specific
11	temperaturen i gemensam ledning före HTFV, 463KB501	Global
12	effekten 613KA901	Specific
13	nivån i mavatanken	Specific
14	temperaturen på mava efter HTFV, 463KB507	Global

Unanticipated Scenario 3: After Detection Period

No	Item	Type
1	turbinens oljetemperatur efter lager 403KA5xx	Global
2	temperaturen efter kondensatpumparna 462KA503	Global
3	dränageflödet till mavatanken, 462KD302	Global
4	temperaturen 462KA503, efter kondensatpumparna	Specific
5	nivån i kondensorn 461KA40x	Global
6	341KB101, tryck före TB1	Specific
7	antalet i drift varande 441 pumpar	Specific
8	effekten 613KA901	Specific
9	temperaturen i gemensam ledning före HTFV, 463KB501	Global
10	trycket i kondensorn	Specific
11	flödet 341KB301	Specific
12	antalet i drift varande mavapumpar 463PX1	Global

Unanticipated Scenario 3: After Mitigation Period

No	Item	Type
1	nivån i kondensorn 461KA40x	Global
2	dränageflödet till mavatanken, 462KD302	Global

3	temperaturen i RI 583KX501	Global RO
4	turbinvarvtalet 452KA812	Global
5	nivån i kondensorn	Specific
6	temperature efter 724 pumpar 724KB505	Specific
7	trycket i kondensorn	Specific
8	antalet i drift varande huvudkylvattenpumpar 441	Global
9	flödet till 341, 341KB301	Global
10	eleffekten 613KA901	Specific
11	nivån i 463EB1 463KA402	Specific
12	temperaturen i RI	Specific RO
13	kondensatflödet 462KB301	Specific
14	turbinens lager vibrationer 403KA7xx	Global

Global Parameters

1	antalet stängda 421 ventiler
2	turbinvarvtalet 452KA812
3	temperaturen efter 422EA1 422KA504
4	nivån i 422TB1 422KB403
5	turbinens lager vibrationer 403KA7xx
6	turbinens oljetemperatur efter lager 403KA5xx
7	trycket i kondensorn 461KA1xx
8	nivån i kondensorn 461KA40x
9	antalet i drift varande huvudkylvattenpumpar 441
10	flödet till 341, 341KB301
11	antalet i drift varande kondensatpumpar 462Px1
12	temperaturen efter kondensatpumparna 462KA503
13	kondensatflödet till mavatanken, 462KB301
14	dränageflödet till mavatanken, 462KD302
15	eleffekten 613KA901
16	temperaturen i gemensam ledning före HTFV, 463KB501
17	temperaturen på mava efter HTFV, 463KB507
18	antalet i drift varande mavapumpar 463PX1
19	summa mavaflöde 312KA031
20	nivån i mavatanken 462KB402

Appendix K

SACRI Sensitivity and Response Bias Formulae

Formulae originally derived in Hogg et al. (1995).

1-p1 p(correct acceptance): number of correct acceptances divided by total number of correct acceptances and false alarms.

p1 p(false alarm): number of false alarms divided by total number of correct acceptances and false alarms.

1-p2 p(hit): number of hits divided by total number of hits and misses.

p2 p(miss): number of misses divided by total number of hits and misses.

p0 p(deviation): i.e. total number of hits and misses divided by total number of questions.

q0 p(non-deviations): i.e. total number of correct acceptances and false alarms divided by the total number of questions.

A'

Non-parametric measure of operator's ability to discriminate stable parameters from those which are fluctuating.

$$A' = 1 - 0.25 \left(\frac{p1}{1 - p2} + \frac{p2}{1 - p1} \right)$$

R:S

Non-parametric measure of response bias.

$$R : S = \frac{q0 * p1 + p0(1 - p2)}{p0}$$