

Qualitative Studies of Nonlinear Hybrid Systems

by

Jun Liu

A thesis

presented to the University of Waterloo

in fulfilment of the

thesis requirement for the degree of

Doctor of Philosophy

in

Applied Mathematics

Waterloo, Ontario, Canada, 2010

©Jun Liu, 2010

Author's Declaration

I hereby declare that I am the sole author of this thesis. This is a true copy of the thesis, including any required final revisions, as accepted by my examiners.

I understand that my thesis may be made electronically available to the public.

Abstract

A hybrid system is a dynamical system that exhibits both continuous and discrete dynamic behavior. Hybrid systems arise in a wide variety of important applications in diverse areas, ranging from biology to computer science to air traffic dynamics. The interaction of continuous- and discrete-time dynamics in a hybrid system often leads to very rich dynamical behavior and phenomena that are not encountered in purely continuous- or discrete-time systems. Investigating the dynamical behavior of hybrid systems is of great theoretical and practical importance.

The objectives of this thesis are to develop the qualitative theory of nonlinear hybrid systems with impulses, time-delay, switching modes, and stochastic disturbances, to develop algorithms and perform analysis for hybrid systems with an emphasis on stability and control, and to apply the theory and methods to real-world application problems.

Switched nonlinear systems are formulated as a family of nonlinear differential equations, called subsystems, together with a switching signal that selects the continuous dynamics among the subsystems. Uniform stability is studied emphasizing the situation where both stable and unstable subsystems are present. Uniformity of stability refers to both the initial time and a family of switching signals. Stabilization of nonlinear systems via state-dependent switching signal is investigated. Based on assumptions on a convex linear combination of the nonlinear vector fields, a generalized minimal rule is proposed to generate stabilizing switching signals that are well-defined and do not exhibit chattering or Zeno behavior.

Impulsive switched systems are hybrid systems exhibiting both impulse and switching effects, and are mathematically formulated as a switched nonlinear system coupled with a sequence of nonlinear difference equations that act on the switched system at discrete times. Impulsive switching signals integrate both impulsive and switching laws that specify when and how impulses and switching occur. Invariance principles can be used to investigate asymptotic stability in the absence of a strict Lyapunov function. An invariance principle is established for impulsive switched systems under weak dwell-time signals. Applications of this invariance principle provide several asymptotic stability criteria. Input-to-state stability notions are formulated in terms of two different measures, which not only unify various stability notions under the stability theory in two measures, but also bridge this theory with the existent input/output theories for nonlinear systems. Input-to-state stability results

are obtained for impulsive switched systems under generalized dwell-time signals. Hybrid time-delay systems are hybrid systems with dependence on the past states of the systems. Switched delay systems and impulsive switched systems are special classes of hybrid time-delay systems. Both invariance property and input-to-state stability are extended to cover hybrid time-delay systems.

Stochastic hybrid systems are hybrid systems subject to random disturbances, and are formulated using stochastic differential equations. Focused on stochastic hybrid systems with time-delay, a fundamental theory regarding existence and uniqueness of solutions is established. Stabilization schemes for stochastic delay systems using state-dependent switching and stabilizing impulses are proposed, both emphasizing the situation where all the subsystems are unstable. Concerning general stochastic hybrid systems with time-delay, the Razumikhin technique and multiple Lyapunov functions are combined to obtain several Razumikhin-type theorems on both moment and almost sure stability of stochastic hybrid systems with time-delay.

Consensus problems in networked multi-agent systems and global convergence of artificial neural networks are related to qualitative studies of hybrid systems in the sense that dynamic switching, impulsive effects, communication time-delays, and random disturbances are ubiquitous in networked systems. Consensus protocols are proposed for reaching consensus among networked agents despite switching network topologies, communication time-delays, and measurement noises. Focused on neural networks with discontinuous neuron activation functions and mixed time-delays, sufficient conditions for existence and uniqueness of equilibrium and global convergence and stability are derived using both linear matrix inequalities and M-matrix type conditions.

Numerical examples and simulations are presented throughout this thesis to illustrate the theoretical results.

Acknowledgments

First and foremost, I want to express my sincere gratitude to both of my supervisors, Professor Xinzhi Liu and Professor Wei-Chau Xie, for their invaluable advice, kindest support, and constant encouragement throughout my graduate studies at the University of Waterloo.

I am grateful to Professor Sue Ann Campbell, Professor Zhong-Ping Jiang, Professor Daniel Miller, Professor David Siegel for serving as my committee members. Their valuable comments and suggestions are very important for improving the quality of this thesis. I also like to extend my appreciation to Professor Hans De Sterck and Professor Andrew Heunis, who together with Professor Sue Ann Campbell and Professor David Siegel, have taught me various aspects of applied mathematics, and to Ms. Helen Warren, for all the help and support she has given me over the past few years.

I like to thank all the friends I have met here at Waterloo, for their friendship and the many wonderful moments they have shared with me, and for their kind help and support during various stages of my stay here.

Financial support through the Ontario Graduate Scholarship, NSERC Canada Graduate Scholarship, University of Waterloo's President Scholarship, as well as other forms of support provided by our department, faculty, and university are gratefully acknowledged.

This thesis would not have been possible without the constant support and encouragement from my family. I dedicate this thesis to them with my deepest gratitude and love.

TO

My Parents, Wife, and Son

Table of Contents

List of Notations	XII
List of Figures	XV
1 Introduction	1
1.1 Hybrid Systems	1
1.1.1 Switched Systems	2
1.1.2 Impulsive Systems	5
1.2 Hybrid Systems with Time-Delay	8
1.3 Stochastic Hybrid Systems	10
1.4 Scope of The Thesis	12

P A R T I

Deterministic Hybrid Systems

2 Switched Nonlinear Systems	16
2.1 Mathematical Formulation	16
2.1.1 Remarks on the Existence and Uniqueness of Solutions	18
2.2 Discussions of Stability and Problem Formulation	19
2.3 Comparison Functions, Multiple Lyapunov Functions, and Derivatives	24
2.4 Uniform Stability of Switched Nonlinear Systems	25
2.4.1 Definitions of Uniform Stability	26
2.4.2 Uniform Stability	28
2.4.3 Uniform Asymptotic Stability	32
2.4.4 Uniform Exponential Stability	37

2.4.5	Uniform Stability of Switched Linear Systems	38
2.4.6	Examples	39
2.5	Switching Stabilization of Nonlinear Systems	45
2.5.1	Notions of (h_0, h) -Stability	47
2.5.2	(h_0, h) -Global Uniform Asymptotic Stabilization	47
2.5.3	(h_0, h) -Global Exponential Stabilization	57
2.5.4	Examples	59
2.6	Summary	72
3	Impulsive Switched Systems	74
3.1	Mathematical Formulation	74
3.1.1	Classes of Generalized Impulsive Switching Signals	76
3.2	Invariance Principles	78
3.2.1	Preliminaries Results	80
3.2.2	A Weak Invariance Principle	84
3.2.3	Stability Criteria	85
3.2.4	Examples	89
3.2.5	An Application to Hybrid Epidemic Dynamics	94
3.3	Input-to-State Stability	97
3.3.1	Definitions of (h_0, h) -Input-to-State Stability	97
3.3.2	Class- \mathcal{KL} estimates	99
3.3.3	Input-to-State Stability	104
3.3.4	Examples	108
3.4	Summary	112
4	Hybrid Systems with Time-Delay	113
4.1	Mathematical Formulation	113
4.1.1	Switched Delay Systems	113
4.1.2	General Hybrid Systems with Time-Delay	114
4.2	Invariance Principles for Switched Delay Systems	115

4.2.1	Preliminary Results	117
4.2.2	A Weak Invariance Principle	123
4.2.3	Stability Criteria	124
4.2.4	Instability	128
4.2.5	Extensions by Multiple Lyapunov-Razumikhin Functions	129
4.2.6	Examples	132
4.3	Input-to-State and Integral Input-to-State Stability	137
4.3.1	Preliminaries	139
4.3.2	Input-to-State Stability	141
4.3.3	Integral Input-to-State Stability	148
4.3.4	Examples	151
4.4	Summary	163

P A R T II

Stochastic Hybrid Systems

5	Stochastic Hybrid Systems with Time-Delay	166
5.1	Fundamental Theory	167
5.1.1	Mathematical Formulation	167
5.1.2	Existence and Uniqueness	169
5.2	Multiple Lyapunov Functions and Itô's Formula	181
5.3	Impulsive Stabilization of Stochastic Delay Systems	182
5.3.1	Mathematical Formulation	182
5.3.2	Moment Exponential Stability	183
5.3.3	Almost Sure Exponential Stability	187
5.3.4	Linear Systems	188
5.3.5	An Example	189
5.4	Switching Stabilization of Stochastic Delay Systems	189
5.4.1	Mathematical Formulation	191

5.4.2	Stabilization of Systems with Linear Drifts	193
5.4.3	Stabilization of Nonlinear Systems	200
5.4.4	Examples	203
5.5	Razumikhin-Type Theorems for Stochastic Hybrid Delay Systems	210
5.5.1	Preliminaries	210
5.5.2	Moment Exponential Stability: Average Dwell-Time Approach	211
5.5.3	Moment Exponential Stability: Impulsive Stabilization	215
5.5.4	Moment Exponential Stability: Combined Hybrid Strategy	219
5.5.5	Almost Sure Exponential Stability	223
5.5.6	Examples	228
5.6	Summary	236

P A R T III

Applications

6	Consensus in Dynamical Networks	240
6.1	Problem Formulation and Consensus Protocols	241
6.1.1	Network Topology	241
6.1.2	Consensus Protocols	242
6.1.3	Network Dynamics	243
6.1.4	Consensus Notions	244
6.2	A Gronwall-Bellman-Halanay Type Inequality	244
6.3	Consensus Results	245
6.3.1	Networks with Fixed Topology	245
6.3.2	Networks with Arbitrarily Switching Topology	249
6.3.3	Networks with Markovian Switching Topology	251
6.4	Simulation Results	251
6.5	Summary	253

7	Dynamics of Neural Networks	255
7.1	Neural Network Model and Preliminaries	257
7.1.1	A Lemma on Existence of Equilibrium Point	259
7.2	Global Stability and Convergence	261
7.2.1	Sufficient Conditions by LMIs	261
7.2.2	Sufficient Conditions by M-Matrix	267
7.3	Local Existence of Solutions	270
7.4	Examples	272
7.5	Summary	274
8	Conclusions and Future Research	276
	Bibliography	279
	Author's Publications	295

List of Notations

This following list aims to provide a quick reference for some mathematical notations used in this thesis. Other notations will be defined at their first appearance.

\mathcal{R}^n	the n -dimensional Euclidean space.
\mathcal{R}^+	the set of all nonnegative real numbers.
\mathcal{Z}	the set of all integers.
\mathcal{Z}^+	the set of all nonnegative integers.
$\mathcal{R}^{n \times m}$	the space of $n \times m$ real matrices.
$C(A; B)$	the set of all continuous functions from A to B , where $A \subset \mathcal{R}^n$ and $B \subset \mathcal{R}^m$.
$C^1(A; B)$	the set of all continuously differentiable functions from A to B .
C	brevity for $C([-r, 0]; \mathcal{R}^n)$, if $r > 0$ is known and fixed.
$C^{1,2}$	brevity for $C^{1,2}(\mathcal{R}^+ \times \mathcal{R}^n; \mathcal{R}^n)$, the set of all functions from $\mathcal{R} \times \mathcal{R}^n$ to \mathcal{R} that are continuously differentiable in the first variable and twice continuously differentiable in the second variable.
$\mathcal{PC}([a, b]; \mathcal{R}^n)$	the class of piecewise continuous functions from $[a, b]$ to \mathcal{R}^n .
$\mathcal{PC}([a, \infty); \mathcal{R}^n)$	all functions $\psi : [a, \infty) \rightarrow \mathcal{R}^n$ with $\psi _{[a,b]}$ (ψ restricted on $[a, b]$) in $\mathcal{PC}([a, b]; \mathcal{R}^n)$ for all $b > a$.
\mathcal{PC}	brevity for $\mathcal{PC}([-r, 0]; \mathcal{R}^n)$, if $r > 0$ is known and fixed.
$\mathcal{PC}[\Theta]$	a subspace of \mathcal{PC} , which contains functions that are continuous on $[-r, 0] \setminus \Theta$ and may have jump discontinuities at the set $\Theta \subset (-r, 0)$.
$ \cdot $	$ x = \sqrt{x_1^2 + x_2^2 + \dots + x_n^2}$ for a vector $x = (x_1, x_2, \dots, x_n)^T \in \mathcal{R}^n$; $ A = \sqrt{\text{trace}(A^T A)} = \sqrt{\sum_{i=1}^n \sum_{j=1}^m a_{ij} ^2}$ for a matrix $A \in \mathcal{R}^{n \times m}$.

$\ \cdot\ $	$\ A\ = \sqrt{\lambda_{\max}(A^T A)}$ for a matrix $A \in \mathcal{R}^{n \times m}$; $\ \phi\ = \sup_{-r \leq s \leq 0} \phi(s) $ for $\phi \in \mathcal{C}$ or \mathcal{PC} .
\mathcal{I}, \mathcal{J}	two index sets. Particularly, \mathcal{I} is used for switching, and \mathcal{J} for impulses.
σ	a switching signal from \mathcal{R}^+ to \mathcal{I} or an impulsive switching signal $\{(t_k, i_k, j_k)\}$, where $i_k \in \mathcal{I}, j_k \in \mathcal{J}, t_k < t_{k+1}$ for all $k \in \mathcal{Z}^+$ and $t_k \rightarrow \infty$ as $k \rightarrow \infty$.
\mathcal{S}	a certain class of (impulsive) switching signals.
Γ	the class of functions $\{h \in C(\mathcal{R}^+ \times \mathcal{R}^n; \mathcal{R}^+) : \inf_{(t,x)} h(t,x) = 0\}$.
(h_0, h)	a pair of two functions in Γ used as stability measures.
$\mathcal{S}_{\text{inf}}^i(\tau)$	the set of (impulsive switching) signals with dwell-time τ in the i th mode.
$\mathcal{S}_{\text{sup}}^i(\tau)$	the set of signals with reverse dwell-time τ in the i th mode.
$\mathcal{S}_{\text{sup}}^u(\tau)$	the set of signals with reverse dwell-time τ in the modes indexed by $\mathcal{I}_u \subset \mathcal{I}$.
$\mathcal{S}_{\mathbf{a}}^i(\tau, N_0)$	the set of signals with average dwell-time τ in the i th mode.
$\mathcal{S}_{\mathbf{ra}}^i(\tau, N_0)$	the set of signals with reverse average dwell-time τ in the i th mode.
$\mathcal{S}_{\text{weak}}^i(\tau, N_0)$	the set of signals with weak dwell-time τ in the i th mode.
$D^+ V_i(t, x)$	the upper right-hand derivative of V_i with respect to the i th mode of a system with switching modes.
$\dot{V}_i(t, x)$	the derivative of V_i with respect to the i th mode of a system with switching modes if V_i is differentiable.
$D^+ V_i(t, \phi)$	the upper right-hand derivative of a functional V_i with respect to the i th mode of a delay system with switching modes.
$D^+ V_i(t, \phi(0))$	the upper right-hand derivative of a function V_i with respect to the i th mode of a delay system with switching modes.

(Ω, \mathcal{F}, P)	a given complete probability space with $\{\mathcal{F}_t\}_{t \geq 0}$ as a filtration satisfying the usual conditions.
$W(t)$	an m -dimensional standard Wiener process defined on (Ω, \mathcal{F}, P) and adapted to $\{\mathcal{F}_t\}_{t \geq 0}$.
$E\{\cdot\}$	the mathematical expectation with respect to the probability measure P .
$\mathcal{L}_{\mathcal{F}_t}^p$	the family of all \mathcal{F}_t -measurable \mathcal{PC} -valued random variables ϕ such that $E\{\ \phi\ ^p\} < \infty$.
$\mathcal{L}_{\mathcal{F}_{t_0}}^b$	the family of \mathcal{PC} -valued random variables that are bounded and \mathcal{F}_t -measurable.
$\mathcal{L}^1([a, b]; \mathcal{R}^n)$	the space of all \mathcal{R}^n -valued \mathcal{F}_t -adapted processes $\{f(t)\}_{a \leq t \leq b}$ such that $\int_a^b f(t) dt < \infty$ almost surely (a.s.).
$\mathcal{L}^2([a, b]; \mathcal{R}^{n \times m})$	the space of all $\mathcal{R}^{n \times m}$ -valued \mathcal{F}_t -adapted processes $\{g(t)\}_{a \leq t \leq b}$ such that $\int_a^b g(t) ^2 dt < \infty$ a.s.
$\mathcal{L}V_i(t, \phi)$	a differential operator from $\mathcal{R} \times \mathcal{PC}$ to \mathcal{R} of a function V_i in $\mathcal{C}^{1,2}$, corresponding to the i th mode of a stochastic delay system with switching modes.
$a \vee b$	the maximum of two real numbers a and b .
$a \wedge b$	the minimum of two real numbers a and b .
$f \circ g$	the composite function defined by $(f \circ g)(x) = f(g(x))$.

List of Figures

1.1	A typical digital control system.	3
1.2	Vibration of a mass with an elastic support.	4
1.3	Switching control.	5
1.4	Impulsive synchronization.	7
1.5	An on/off water level control system.	8
1.6	Four modes of the water level control system.	9
2.1	Individual phase portraits for systems (2.2.1) and (2.2.2).	19
2.2	Phase portrait for the switched system given by (2.2.1) and (2.2.2).	20
2.3	Switching between stable systems.	21
2.4	Switching between unstable systems.	21
2.5	Simulation for Example 2.4.2 with switching signal (2.4.45) and initial condition $x(0)=[5 \ 5]$.	41
2.6	Simulation for Example 2.4.2 with switching signal (2.4.46) and initial condition $x(0)=[5 \ 5]$.	42
2.7	Simulation for Example 2.4.3 with switching signal (2.4.47) and initial condition $x(0)=[-5 \ 5]$.	43
2.8	Stabilized switching solutions with initial data $[5.5 \ 4.5]$ at $t_0 = 0$ for the switched system given by (2.5.10) and (2.5.11).	64
2.9	Stabilized switching solutions with initial data $[2 \ 2]$, $[-2 \ -2]$, $[-2 \ 1.5]$, and $[2 \ -1.5]$ at $t_0 = 0$ for the switched system given by (2.5.18) and (2.5.19).	66
2.10	Phase portraits for subsystems (2.5.22) (left) and (2.5.23) (right).	70

2.11	Stabilizing switching domains for the switched system given by (2.5.22) and (2.5.23).	70
2.12	Stabilized switching solutions with initial data $[5 \ 5]$, $[5 \ -5]$, $[-5 \ 5]$, and $[-5 \ -5]$ at $t_0 = 0$.	71
3.1	Numerical simulations for a switched SEIR model with and without pulse treatment.	96
4.1	Simulation results for Example 4.3.1.	154
4.2	Simulation results for Example 4.3.3.	160
4.3	Simulation results for Example 4.3.4.	161
4.4	Chaotic behavior of $x(t)$ in equation (4.3.30), with $a = -0.16$, $b = 0.4$, $c = 1.8$, $r = 4.8$, and $w(t) \equiv 0$.	162
5.1	Simulation results for Example 5.3.1: (a) impulsive stabilization of system (5.3.1) (multiple samples); (b) impulsive stabilization of system (5.3.1) (single sample); (c) system response without impulses (multiple samples); (d) system response without impulses (single sample).	190
5.2	The solution of the system switching between (5.4.22) and (5.4.23) according to the switching signal $\sigma(t)$. The time-delay is set to be $h = 0.0016$ and the initial data given by $x = [1 \ -1]^T$.	205
5.3	The Euclidian norm $ x $ and quadratic norm $\sqrt{x^T P x}$ versus the constructed switching signal $\sigma(t)$.	205
5.4	The solution of subsystem (5.4.22) without uncertainty and stochastic perturbation. The time-delay is set to be $r = 0.0005$ and the initial data given by $x = [0.01 \ 0.01]^T$.	206
5.5	The solution of subsystem (5.4.23) without uncertainty and stochastic perturbation. The time-delay is set to be $r = 0.0005$ and the initial data given by $x = [0.01 \ 0.01]^T$.	206
5.6	The solution of the system switching between (5.4.24) and (5.4.25) according to the switching signal $\sigma(t)$. The time-delay is set to be $h = 0.02$ and the initial data given by $x = [1 \ -1]^T$.	208

5.7	The Euclidian norm of x versus the constructed switching signal $\sigma(t)$. Note that in this case $P = I_2$ and the quadratic norm $\sqrt{x^T P x}$ coincides with the Euclidian norm.	208
5.8	The solution of subsystem (5.4.24) without uncertainty and stochastic perturbation. The time-delay is set to be $r = 0.02$ and the initial data given by $x = [0.01 \ 0.01]^T$.	209
5.9	The solution of subsystem (5.4.25) without uncertainty and stochastic perturbation. The time-delay is set to be $r = 0.02$ and the initial data given by $x = [0.01 \ 0.01]^T$.	209
5.10	Simulation results for Example 5.5.1.	233
5.11	Simulation results for Example 5.5.1.	234
5.12	Simulation results for Example 5.5.1.	235
6.1	Delayed measurements with additive noises.	243
6.2	Three different network topologies of 3-agents.	251
6.3	Simulation results for fixed topology \mathcal{G}_1 : the left figure shows results for $c(t) = 1/(t + 1)$ and $\tau = 0.499$; the right figure shows results for $c(t) = 1$ and $\tau = 0.499$.	252
6.4	Simulation results for a Markovian switching topology among $\{\mathcal{G}_1, \mathcal{G}_2, \mathcal{G}_3\}$ driven by the generator $\Gamma = [-0.5 \ 0.2 \ 0.3; 0.4 - 0.7 \ 0.3; 0.2 \ 0.55 - 0.75]$: the left figure shows results for $c(t) = 1/(t + 1)$ and $\tau = 0.111$; the right figure shows results for $c(t) = 1/(t + 1)^2$ and $\tau = 0.111$.	252
7.1	Simulation results for Example 7.4.1.	272
7.2	Simulation results for Example 7.4.2.	273
7.3	Simulation results for Example 7.4.2.	274

C H A P T E R

1

Introduction

1.1 Hybrid Systems

Due to their many important applications, hybrid systems are currently becoming a large and growing interdisciplinary area of research (see, e.g., [55], [142], [158] and references therein). A *hybrid system* is a dynamical system that exhibits both continuous and discrete dynamic behavior. Typical examples that involve hybrid characteristics of both continuous and discrete dynamics include

- *switched electrical circuits*, in which voltages and currents change continuously according to classical laws of electrical networks and also undergo abrupt changes due to switching on and off.
- *classical mechanics*, in which velocities of a multibody system change continuously according to Newton's second law but undergo instantaneous changes in velocity and momentum due to collisions.
- *biological systems*, in which continuous changes are maintained during normal operations and sudden changes occur due to impulsive stimuli. Further examples include seasonal harvesting in population dynamics [21], periodic treatment and/or vaccination in epidemic models ([114], [166]), and seasonality in ecosystems ([159], [166]), which all lead to interactions of discrete and continuous dynamics.
- *embedded systems*, in which digital software interacts with an analog environment. Particular examples include automotive electronics, ranging from simple software-

based automatic gear shifting to complex products such as autonomous cruise control systems [165].

- **communication systems**, in which each individual system changes continuously except that, at discrete times, state variables are sampled and sent from transmitter to the receiver to update the receiver's states ([87], [88], [89], [145], [191]). Therefore, communications here are achieved by sudden impulses.
- **complex networks**, in which each coupled dynamical system often evolves continuously, while the network topology can change abruptly due to reasons such as node and link failures/creations, packet-loss, and formation reconfiguration. Collective properties, such as consensus and synchronization, are largely affected by the changing network structures ([147], [148], [167]). In addition, many biological systems over a network communicate by sudden impulses, e.g., neuron firing, firefly flashing, or cricket chirping [167]. As the study of networks pervades all areas of science [167], it is no surprise that hybrid systems can find applications in a wide variety of disciplines.
- **control systems**, in which stabilizing hybrid controllers (continuous, switching, impulse, or a combination of these) can be designed to control a plant described by a nonlinear system. This type of control appears in a wide class of industrial applications, where logic controllers and microprocessors are programmed for automation. In these applications, discrete states are used to implement control logic to incorporate decision-making capabilities into the control system [55]. A typical digital control system is shown in Figure 1.1.

The interaction of continuous- and discrete-time dynamics in a hybrid system often leads to very rich dynamical behavior and phenomena that are not encountered in purely continuous- or discrete-time systems [55]. In the following, we further introduce two subclasses of hybrid systems, i.e., switched systems and impulsive systems, that are most commonly encountered in applications.

1.1.1 Switched Systems

A **switched system** is a hybrid dynamical system consisting of a family of continuous subsystems and a logic-based rule that actively selects the continuous dynamics. Switched systems are appropriate models for many systems encountered in practice that exhibit switching among several subsystems in a dynamically changing environment. Switched systems have found applications in control of mechanical systems, automotive industry,

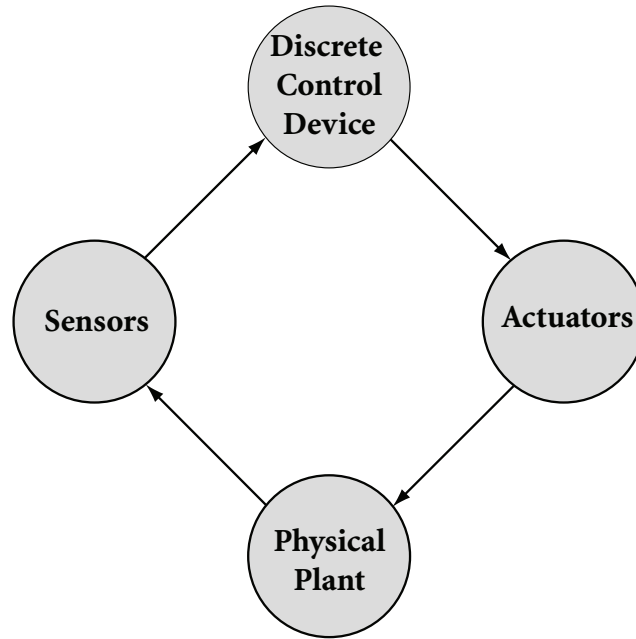

Figure 1.1 A typical digital control system.

aircraft and air traffic control, switching power converters, and many other fields (see, e.g., [106], [107], [142], [158], [161] and references therein).

Example 1.1.1 (Mass-Spring System) As a motivating example for switched systems, consider the vibration of a mass with an elastic support as shown in Figure 1.1.1. The mass is connected to a spring of stiffness K to the left and subjected to an external force $F(t)$. On the right, there is an elastic wall consisting of a spring of stiffness k and a dashpot damper with damping coefficient c . The equilibrium position of the system is denoted by the dashed line. Denote by x_1 the displacement of the mass with respect to the equilibrium position. According to the sign of x_1 , this mechanic system consists of two modes:

(i) **Mode 1:** for $x_1 \leq 0$,

$$\begin{aligned}\dot{x}_1 &= x_2, \\ \dot{x}_2 &= \frac{1}{M}[F(t) - Kx_1],\end{aligned}$$

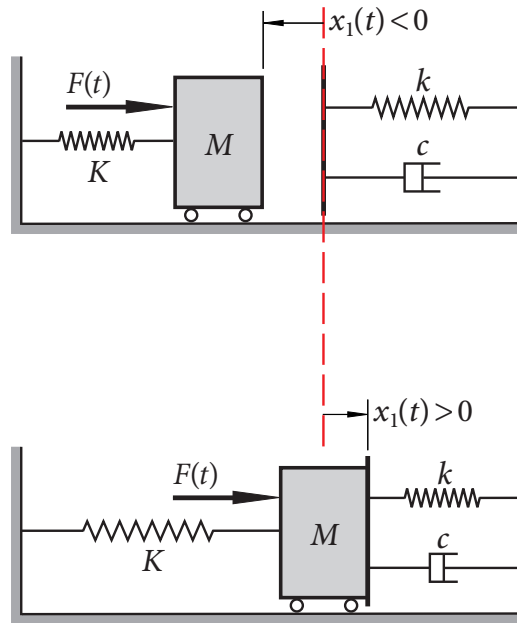

Figure 1.2 Vibration of a mass with an elastic support.

(ii) **Mode 2:** for $x_1 > 0$,

$$\dot{x}_1 = x_2,$$

$$\dot{x}_2 = \frac{1}{M}[F(t) - (K + k)x_1 - cx_2]. \quad \square$$

Example 1.1.2 (Temperature Control) As another motivating example of switched systems, consider the heating and cooling in a house controlled by a furnace and an air conditioner. A simple thermostat controls the temperature with set values of T_{\min} (lowest desired temperature) and T_{\max} (highest desired temperature) as follows. Let T denote the current temperature.

- (i) If $T_{\min} < T < T_{\max}$, both the furnace and air conditioner are kept off. The evolution of T is governed by $\dot{T} = f_1(T)$.
- (ii) If $T > T_{\max}$, the air conditioner is turned on and the furnace is off. The evolution of T is governed by $\dot{T} = f_2(T)$.
- (iii) If $T < T_{\min}$, the furnace is turned on and the air conditioner is off. The evolution of T is governed by $\dot{T} = f_3(T)$.

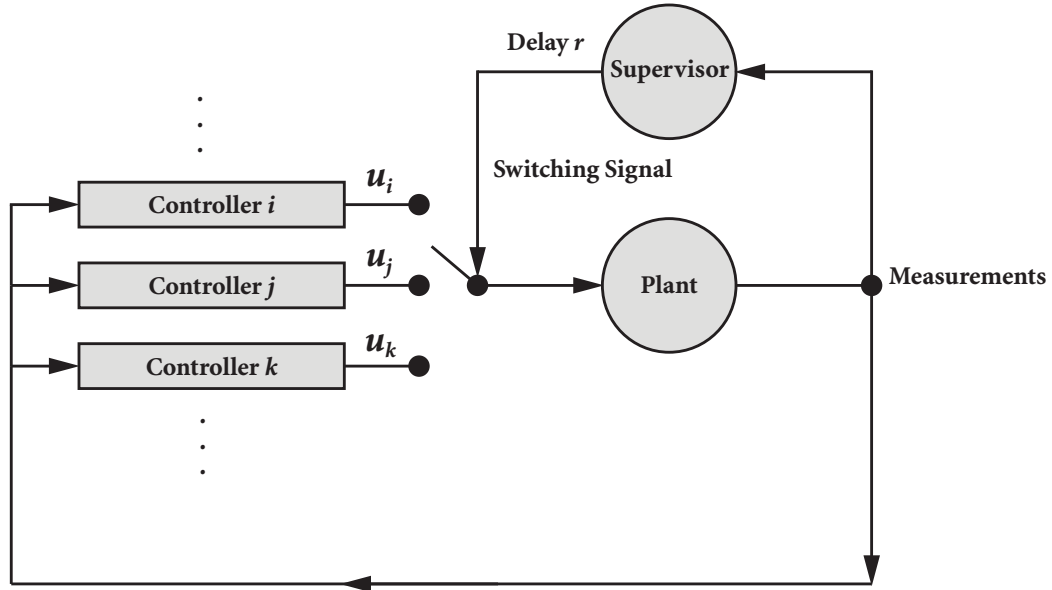

Figure 1.3 Switching control.

Therefore, the dynamics is described by a simple switched system with three different modes. \square

The above example can be generalized to a more general and practical setting.

Example 1.1.3 (Switching Control) Consider a nonlinear control system given by

$$\dot{x} = f(x) + g(x)u_i(x), \quad (1.1.1)$$

where $u_i(x)$ is the feedback control chosen from a family of functions $\{u_i : i \in \mathcal{I}\}$, where \mathcal{I} is an index set, and f and g are both nonlinear functions of x . The switching among the controllers can be autonomously driven by time or state or both, or be controlled by a “higher process” called a supervisor, as shown in Figure 1.3. Here we have assumed that the measurements are sent to the supervisor instantly and decision is made in a prompt sense so that there is no delay in the switching control process ($r = 0$ in Figure 1.3). System (1.1.1) describes a typical situation where switched systems arise from applications. \square

1.1.2 Impulsive Systems

Systems of impulsive differential equations or *impulsive systems* model real world processes that undergo abrupt changes (impulses) in the state at discrete times [97]. Particularly,

impulse control and stabilization as a powerful tool to achieve stability for dynamical systems that can be highly unstable, in the absence of impulses, has gained increasing popularity ([13], [119], [130], [160], [178], [193]) and found successful applications in a wide variety of areas, such as control systems ([10], [120]), control and synchronization of chaotic systems ([87], [88], [89], [122], [124], [123], [128], [191]), complex dynamical networks ([108], [200]), large-scale dynamical systems [192], secure communication ([87], [88], [191]), spacecraft maneuvers [31], population growth and biological systems ([112], [121]), neural networks ([116], [123]), ecosystems management [146], and pharmacokinetics [12].

Impulsive dynamical systems can be naturally viewed as a class of hybrid systems that consist of three elements: a continuous differential equation, which governs the continuous evolution of the system between impulses; a difference equation, which governs the way the system states are changed at impulse times; and an impulsive signal for determining the impulse times.

Example 1.1.4 (Impulsive Synchronization) Consider a cryptosystem based on impulsive synchronization between a drive system and a receiver system. Only samples of the drive system state at discrete times $t_k, k = 1, 2, \dots$, are transmitted to the receiver system through a public channel. We use $x(t)$ to denote the drive system state and $u(t)$ the receiver system state. The objective is to use the sequence of states $\{x(t_k) : k = 1, 2, \dots\}$ sampled from the drive system to update the receiver system according to

$$u(t_k) = u(t_k^-) - B_k [x(t_k) - u(t_k^-)], \quad k = 1, 2, \dots,$$

where each B_k is a constant matrix and $u(t_k^-)$ denotes the left limit of u at t_k , so that in the long term the receiver system and drive system are synchronized, i.e., the error $e(t) = x(t) - u(t)$ goes to 0 as $t \rightarrow \infty$. This procedure is illustrated in Figure 1.4. We have assumed that the sampled data are sent to the receiver instantly and there are no communication time-delays ($r_k = 0$ in Figure 1.4). Now suppose that the drive system is given by

$$\dot{x} = Ax + \Omega(x).$$

Then the receiver system subject to the same nonlinear dynamic and the impulsive synchronization scheme is given by

$$\begin{cases} \dot{u} = Au + \Omega(u), & (1.1.2a) \\ \Delta u = -B_k e(t_k^-). & (1.1.2b) \end{cases}$$

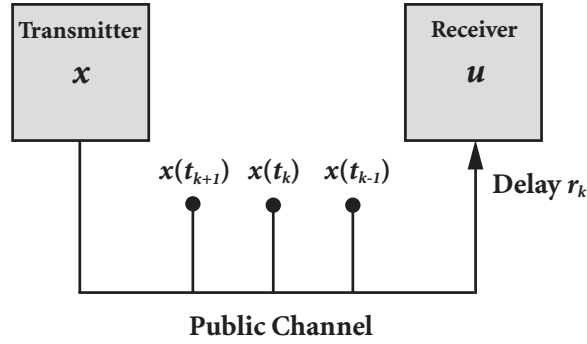

Figure 1.4 Impulsive synchronization.

Therefore, the error dynamics is given by

$$\begin{cases} \dot{e} = Ae + [\Omega(x) - \Omega(u)], & (1.1.3a) \\ \Delta e = B_k e(t_k^-). & (1.1.3b) \end{cases}$$

Both system (1.1.2) and system (1.1.3) are examples of impulsive systems. \square

Both as hybrid systems, impulsive systems and switched systems can be naturally combined to form a more comprehensive model, i.e., *impulsive switched systems*. As early as in 1984, switching and impulses were combined to provide control for a reflected diffusion [105]. Stability analysis of impulsive switched systems has received increasing attention in the past decade (see, e.g., [129], [185], [188], [189], [190]).

The following example shows a simple situation where both impulses and switching can be integrated in the same framework.

Example 1.1.5 (Water Level Control) Figure 1.5 shows a simple on/off water level monitor system. A sensor is used to measure the current level of the water tank, denoted by $y(t)$. Based on the current water level $y(t)$, a digital control device sends a signal $S(t)$ to control the pump:

- (i) if $y(t) \geq 10$, $S(t) = 0$ is sent to turn the pump off; and
- (ii) if $y(t) \leq 2$, $S(t) = 1$ is sent to turn the pump on.

Suppose that there are 2 seconds delay for the signal to reach the pump. We use $x(t)$ to denote the time elapsed since last signal. The dynamics of the system is shown in Figure 1.6,

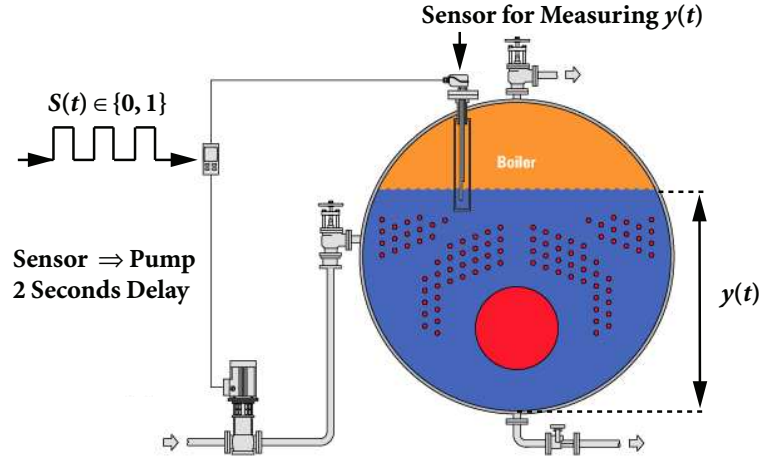

Figure 1.5 An on/off water level control system.

which has four different modes. The equations of dynamics are

$$\begin{cases} z' = f_\alpha(t, z), & \alpha \in \{1, 2, 3, 4\}, \\ \Delta z = g_\alpha(\tau_k, z), & k = 1, 2, \dots, \end{cases}$$

where $z = [x \ y]^T$, $\Delta z = z(\tau_k) - z(\tau_k^-)$, and

$$g_\alpha(\tau_k, z) = \begin{cases} \begin{pmatrix} 0 \\ 0 \end{pmatrix}, & \alpha = 1, 3, \\ \begin{pmatrix} -x(\tau_k^-) \\ 0 \end{pmatrix}, & \alpha = 2, 4, \end{cases}$$

where τ_k are the impulsive switching times and $z(\tau_k^-)$ denotes the left limit of z at τ_k . \square

1.2 Hybrid Systems with Time-Delay

Most of the hybrid models currently considered in the literature use ordinary differential equations (ODEs). These ODE-based models assume that the system under consideration is governed by a principle of causality, i.e., the future state of the system is independent of the past states and depends only on the present state. It is well-known that the principle of

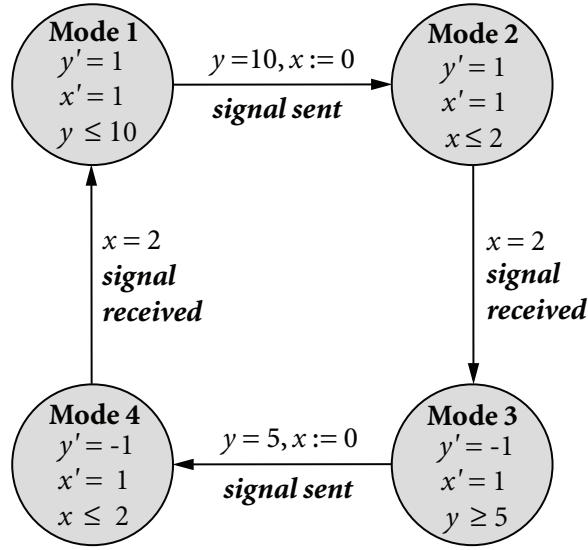

Figure 1.6 Four modes of the water level control system.

causality is usually only a first approximation to the real situation. In many applications, a more realistic model has to include some of the past states of the system, which leads to time-delay models using delay (retarded or functional) differential equations in the classical setting (see, e.g., [44], [45], [61], [62], [93], [94]) or its stochastic counterpart, stochastic delay (retarded or functional) differential equations (see, e.g., [93], [140], [143]).

Incorporating time delay in the hybrid models gives rise to *hybrid (time-)delay systems*. Two important classes of hybrid delay systems are *impulsive delay systems* and *switched delay systems*, both of which received increasing attention in recent years. The following are two examples of hybrid delay systems.

Example 1.2.1 (Delayed Feedback Control) If time-delay r is not 0 in Example 1.1.3, the dynamics of the switching control system is governed by

$$\dot{x} = f(x) + g(x)u_i(x(t - r)), \quad (1.2.1)$$

which is a switched system with a constant time-delay of size r . \square

Example 1.2.2 (Impulsive Synchronization with Delay) If time-delays r_k are not 0 in Example 1.1.4, then the dynamics of receiver system and the error dynamics is given by

$$\begin{cases} \dot{u} = Au + \Omega(u), & (1.2.2a) \\ \Delta u = -B_k e((t_k - r_k)^-), & (1.2.2b) \end{cases}$$

and

$$\begin{cases} \dot{e} = Ae + [\Omega(x) - \Omega(u)], & (1.2.3a) \\ \Delta e = B_k e((t_k - r_k)^-). & (1.2.3b) \end{cases}$$

which are both impulsive systems with various constant time-delays given by r_k , $k = 1, 2, \dots$. \square

Communication delays usually play a key role in the performance of a control system. Including time delay also makes a hybrid system infinite dimensional and hence its stability analysis more involved and challenging, which is in accordance with what has been observed in stability analysis of delay differential equations. Moreover, the combination of impulse and delay effects in impulsive delay systems gives rise to a myriad of problems when studying some basic properties of impulsive delay differential equations ([8], [9], [111]).

1.3 Stochastic Hybrid Systems

The theory of stochastic differential equations was originally developed by mathematicians as a tool for explicitly constructing the trajectories of diffusion processes with given drift and diffusion coefficients [80]. In the physical and engineering sciences, stochastic differential equations arise in a quite natural manner in systems with the so-called “white noise” effects [2]. For example, the investigation of various engineering systems subjected to parametric and external random excitation leads to stochastic differential equations [187]. Typical examples include buildings under earthquake and wind loads, ocean platforms subjected to wave-induced loads, vehicle running on a rough road, aircrafts in a turbulent stream. Stability of these systems are of practical importance.

Even though deterministic hybrid models can capture a wide range of behaviors encountered in practice, stochastic features are also very important, because of the uncertainties inherent in most applications and environmental noise ubiquitous in the real world. There has been increasing interest in *stochastic hybrid systems* due to their many applications in areas such as insurance pricing, power industry, flexible manufacturing, fault tolerant control, maneuvering aircraft, and communication networks (see, e.g., [16], [32], [137] and references therein). The theory of stochastic differential equations and stochastic processes provides necessary tools to formulate and study stochastic hybrid systems.

Example 1.3.1 (Stochastic Impulsive Control) Impulsive control has long been used in the control of stochastic systems [95] (see also [96]). Let (Ω, \mathcal{F}, P) be a complete probability space equipped with a filtration \mathcal{F}_t . In [95], an impulsive control is given by sequence of pair $\{(\xi_k, \tau_k) : k = 1, 2, \dots\}$, where τ_k is a sequence of $\{\mathcal{F}_t\}$ -stopping times with $\tau_k \leq \tau_{k+1} \rightarrow \infty$ as $k \rightarrow \infty$, and ξ_k is a sequence of random variables that are \mathcal{F}_{τ_k} -measurable. Consider an Itô process given by

$$dx(t) = b(x(t))dt + \sigma(x(t))dW(t), \quad (1.3.1)$$

where $W(t)$ is a standard Wiener process on (Ω, \mathcal{F}, P) . Applying the impulsive control $\{(\xi_k, \tau_k) : k = 1, 2, \dots\}$ to (1.3.1) gives

$$\begin{cases} dx(t) = b(x(t))dt + \sigma(x(t))dW(t), & t \neq \tau_k, \\ \Delta x(t) = D\xi_k, & t = \tau_k, \end{cases} \quad (1.3.2a)$$

$$(1.3.2b)$$

where D is a matrix, which is understood in the integral sense as

$$x(t) = x(0) + \int_0^t b(x(s))ds + \int_0^t \sigma(x(s))dW(s) + \sum_{0 \leq \tau_k \leq t} D\xi_k.$$

As pointed out in [96], compared with a continuous control, there is usually a positive cost for setting up an impulse control, and a cost associated with the magnitude of the control. Once a cost function (or functional) is specified and one is asked to minimize the cost of an impulse control, an optimal impulse control problem is proposed. \square

Example 1.3.2 (Stochastic Switched Systems) Consider the Lotka-Volterra equations for the population dynamics of two species in a random environment

$$\begin{cases} \dot{x}(t) = x(\alpha_i - \beta_i y) + \lambda_i dW_1(t), \\ \dot{y}(t) = -y(\gamma_i - \delta_i x) + \mu_i dW_2(t), \end{cases} \quad (1.3.3a)$$

$$(1.3.3b)$$

where $\alpha_i, \beta_i, \gamma_i$, and δ_i are parameters representing the interaction of the two species, and λ_i and μ_i are the noise intensities. Here the environmental noises are modeled with two independent scalar Wiener processes W_1 and W_2 . The changes in parameters are modeled by allowing them to switch among a family $\{(\alpha_i, \beta_i, \gamma_i, \delta_i, \lambda_i, \mu_i) : i \in \mathcal{I}\}$, driven by a time-dependent process $i(t)$ or by the state $(x(t), y(t))$ in the sense that $i = i(x(t), y(t))$ is a function of $(x(t), y(t))$.

This model is motivated by the fact that the growth rates and the carrying capacities of the species in an ecosystem, determined by the parameters $\alpha_i, \beta_i, \gamma_i$, and δ_i , are often

not only subject to environmental noises, but also to seasonal, regional, or other changes. These changes usually cannot be described by the traditional (deterministic or stochastic) Lotka-Volterra models. For instance, the growth rates of certain species can be higher in the rainy season than in the dry season; the carrying capacities can vary due to changes in nutrition and food resources. System (1.3.3) is understood in the Itô sense. \square

Stochastic hybrid systems can be formulated either by adding noise effects to a deterministic hybrid system or by adding hybrid effects, such as parameter switching and/or state jumps, to a continuous stochastic differential equation. The dynamical behavior of a stochastic hybrid system can be very different from its deterministic counterpart. Different notions of stability, such as almost sure (sample) stability and moment stability, arise in the stochastic setting.

As in the deterministic case, one of the major difficulties encountered in studying *stochastic hybrid systems with time-delay* is caused by a fundamental difference that impulse effects bring to the studies of delay differential equation, which is that, due to the impulse effects, solutions of impulsive delay differential equations are no longer continuous functions of the time and hence they have to be considered to be evolving in the space of piecewise continuous functions. This key difference causes a myriad of problems when studying some basic properties of impulsive delay differential equations as shown in [8], [9], and [111]. These problems naturally carry over to the stochastic setting and are part of the main issues to be addressed later in this thesis.

1.4 Scope of The Thesis

This thesis focuses on the qualitative studies of hybrid dynamical systems, emphasizing systems with nonlinear structures, time-delays, and stochastic disturbances. The thesis is divided into three parts, i.e., Part I: Deterministic Hybrid Systems, Part II: Stochastic Hybrid Systems, and Part III: Applications.

We begin by a systematic study of switched nonlinear systems in Chapter 2. Mathematical formulation is given for switched nonlinear systems, followed by a detailed discussions on stability. The main stability problems are then formulated and studied. Particularly, two important problems, i.e., uniform stability for switched nonlinear systems with both stable and unstable subsystems, and switching stabilization of a family of unstable nonlinear systems, are investigated.

Chapter 3 presents qualitative studies of impulsive switched systems. Impulsive switched systems are formulated and several classes of impulsive switching signals are presented. Under this formulation, an invariance principle is first established under weak dwell-time signals, and input-to-state stability properties are investigated, taking both impulsive and switching effects into account.

Chapter 4 studies hybrid systems with time-delay. Both switched delay systems and general hybrid systems with time-delay are investigated. An invariance principle is obtained for switched delay systems under weak dwell-time signals and input-to-state stability properties are investigated for general hybrid systems with time-delay. The results in this chapter partially extend the results in Chapter 3 to hybrid systems with time-delay.

Chapter 5 is the only chapter in Part II, which focuses on stochastic hybrid systems with time-delay. We begin by presenting a general mathematical formulation and establishing the fundamental theory regarding existence and uniqueness of solutions. Before presenting general stability theorems of stochastic hybrid systems with time-delay, we investigate two particular situations, in which impulses and switching are applied, respectively, to stabilize otherwise unstable switched delay systems. Then in a very general setting, we apply the Razumikhin method and multiple Lyapunov functions to obtain several Razumikhin-type theorems on both moment and almost sure stability of stochastic hybrid systems with time-delay.

Part III presents two application problems that are related to qualitative studies of hybrid dynamical systems. In Chapter 6, we investigate the consensus problem in networks of dynamical systems, in which stochastic noise, switching network topology, and communication time-delays are studied in the same framework and sufficient conditions for reaching consensus among networked agents are obtained. Chapter 7 presents a study of the dynamical behavior of delayed neural networks, in which we follow a recently developed model and focus on neural networks with discontinuous neuron activation functions and mixed time-delays. Sufficient conditions for existence and uniqueness of equilibrium and global convergence and stability are derived using both linear matrix inequalities and M-matrix type conditions.

Numerical examples and simulations are presented throughout this thesis to illustrate the theoretical results. Finally, Chapter 8 presents some conclusions and discusses some future research along the lines of this thesis.

P A R T I

Deterministic Hybrid Systems

C H A P T E R

2

Switched Nonlinear Systems

As introduced in Chapter 1, a switched system is a hybrid system consisting of a family of continuous subsystems and a logic-based rule that actively selects the continuous dynamics. Switched systems are appropriate models for many systems encountered in practice that exhibit switching between several subsystems, and have numerous applications in a variety of areas. In this chapter, we will focus on switched nonlinear systems and investigate some relevant stability issues.

2.1 Mathematical Formulation

Switched systems can be mathematically understood as differential equations with discontinuous righthand sides, which are well studied in the monograph [48]. However, one has to get familiar with concepts such as Carathéodory differential equations and differential inclusions to understand the results in [48], which would complicate the study and applications. Here we prefer a more straightforward approach, which regards a switched system as a family of continuous-time systems, together with a switching rule that chooses an active subsystem from the family at every instant of time [107].

In this sense, a general nonautonomous *switched nonlinear system* can be described by

$$\dot{x}(t) = f_{\sigma}(t, x(t)), \quad t \geq t_0, \quad (2.1.1)$$

where σ , called a *switching signal*, is a function defined on $\mathcal{R}^+ \times \mathcal{R}^n$ and valued in an index set \mathcal{I} . The role of a switching signal is to select the right-hand side of (2.1.1) from a parameterized family of nonlinear vector fields $\{f_i : i \in \mathcal{I}\}$, where $f_i : \mathcal{R}^+ \times \mathcal{R}^n \rightarrow \mathcal{R}^n$,

depending on evolution of time t and state x . The time instants at which σ changes its value are called **switching times** of this particular switching signal. If explicitly considered, the switching times (together with the initial time t_0) are always denoted by $\{t_k : k \in \mathcal{Z}^+\}$, where $t_k < t_{k+1}$ for all $k \in \mathcal{Z}^+$ and \mathcal{Z}^+ denotes the set of all nonnegative integers.

The arbitrary nature of the switching signal σ causes difficulties in the study of (2.1.1). We formulate two particular types of switching signals that have been most studied in the literature.

- **Time-dependent switching:** σ is a function of the time t alone, i.e., σ is a function from \mathcal{R}^+ to \mathcal{I} . A typical example is that σ is a piecewise constant function from \mathcal{R}^+ to \mathcal{I} .
- **State-dependent switching:** σ is a function of the state x alone, i.e., σ is a function (possibly multi-valued) from \mathcal{R}^n to \mathcal{I} . A typical example is when the space is partitioned into a finite or infinite number of regions by means of a family of switching surfaces. In each of these regions, a single subsystem is activated and the system changes mode when crossing a switching surface.

However, even if we know that σ is solely time-dependent or state-dependent, there are some extreme cases which may complicate the study of (2.1.1). In the case of time-dependent switching, a common problem is caused by the so-called **Zeno behavior** when the switching instants have a finite accumulation point [107]. In the case of state-dependent switching, a **sliding mode** occurs when the vector fields on both sides of a switching surface are pointing toward this surface [107]. This difficulty can be overcome by introducing the concept of differential inclusions [48]. However, we are not going to pursue this approach for reasons explained earlier. In what follows, we will propose reasonable assumptions to rule out these singularities and focus our attention on the stability analysis of switched systems. Moreover, note that it is actually difficult to make a formal distinction between state-dependent and time-dependent switching, since every possible trajectory of the system with state-dependent switching is also a solution of the system with time-dependent switching for a suitably defined switching signal.

System (2.1.1) is more general than the autonomous switched system

$$\dot{x} = f_\sigma(x), \quad t \geq 0.$$

Moreover, under time-dependent switching, a key distinction between system (2.1.1) and the nonautonomous (time-varying) system

$$\dot{x} = g(t, x), \quad t \geq t_0, \quad (2.1.2)$$

where $g(t, x) = f_{\sigma(t)}(t, x)$, $t \geq t_0$, is that one typically associates a family of admissible switching signals \mathcal{S} to (2.1.1) and studies the properties of solutions to (2.1.1) as σ ranges over \mathcal{S} . Of particular interest are the properties that remain uniform with respect to all σ over \mathcal{S} , which have been well-studied in [69] for switched linear systems. This distinction is based on the fact that solutions to a switched system such as (2.1.1) are parameterized by a set of initial conditions as well as a set of admissible switching signals \mathcal{S} in which σ is assumed to lie, which is in contrast with a time-varying system such as (2.1.2), whose solutions are parameterized solely by a set of initial conditions. This observation poses important questions related to the uniformity of properties, such as stability, boundedness, and convergence, as σ ranges over \mathcal{S} . Even if system (2.1.1) is linear, it has been shown in [69] that uniformity of these properties is not easily obtained; under certain conditions, a smaller set of admissible switching signals \mathcal{S} has to be specified to guarantee the uniformity of asymptotic properties [69]. Clearly, when a single time-dependent switching signal σ is specified, (2.1.1) and (2.1.2) represent exactly the same object. Another important distinction between a switched system and a time-varying system is that the switching signal in a switched system can be chosen by some “higher process” such as a controller, computer, or human operator, which results in switching control for a family of systems [20].

2.1.1 Remarks on the Existence and Uniqueness of Solutions

The existence and uniqueness of solutions of system (2.1.1) with initial condition $x(t_0) = x_0 \in \mathcal{R}^n$ is almost trivial in the time-dependent switching case, since it follows from the fundamental theory of ordinary differential equations (ODEs) plus a *method of steps*, i.e., we can solve the initial value problem for the current switching interval $[t_k, t_{k+1}]$ and use the value of $x(t_{k+1})$ as an initial value to formulate and solve the initial value problem on the next switching interval $[t_{k+1}, t_{k+2}]$, and so on. Conditions on the vector fields, such as continuity in t and Lipschitz continuity in x that guarantee existence and uniqueness for ODEs, can be carried over to this case. A general assumption is that each f_i in (2.1.1) is locally Lipschitz in its second variable and continuous in the first. However, uniqueness of

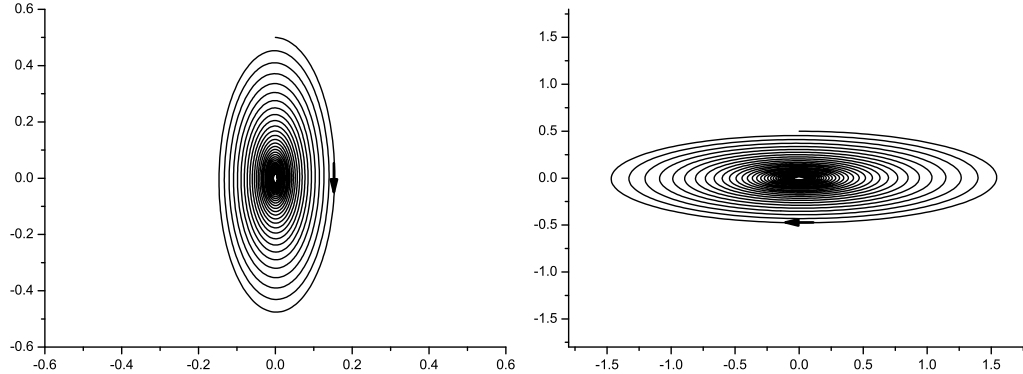

Figure 2.1 Individual phase portraits for systems (2.2.1) and (2.2.2).

solutions is not essential while developing the stability theory for systems such as (2.1.1), which is in accordance with similar remarks for nonlinear systems without switching [60]. Even without this uniqueness assumption, we may still show that all possible solutions will converge to a *unique* equilibrium point (trivial solution) if stability is concerned, and the uniqueness of the trivial solution is usually implied by stability (i.e., $x(t_0) = 0$ implies $x(t) \equiv 0$ for all $t \geq t_0$).

In contrast to the fundamental theory, the stability analysis of switched systems is not a trivial one, as we shall show in what follows.

2.2 Discussions of Stability and Problem Formulation

The challenge to analyze the stability of switched systems lies partly in the fact that even if the individual systems are stable, the switched system might be unstable, which is well illustrated in the following example.

Example 2.2.1 Consider a switched system with two subsystems:

$$\dot{x}(t) = \begin{bmatrix} -0.1 & 1 \\ -10 & -0.1 \end{bmatrix} x(t) \quad (2.2.1)$$

and

$$\dot{x}(t) = \begin{bmatrix} -0.1 & 10 \\ -1 & -0.1 \end{bmatrix} x(t). \quad (2.2.2)$$

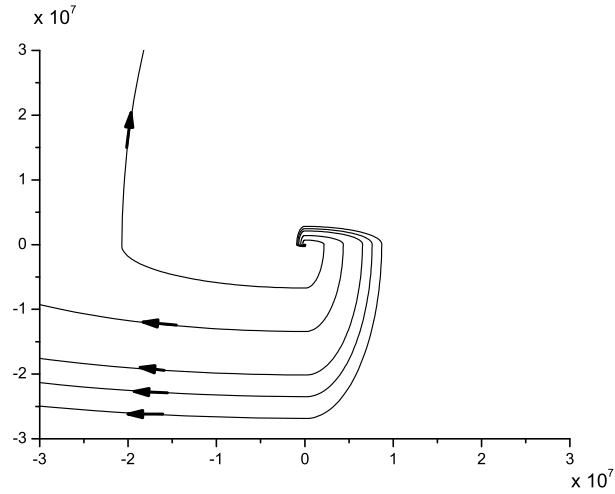

Figure 2.2 Phase portrait for the switched system given by (2.2.1) and (2.2.2).

Specify a state-dependent switching signal $\sigma : \mathcal{R}^2 \rightarrow \{1, 2\}$ by letting $\sigma((x_1, x_2)) = 1$ if $x_1 x_2 \leq 0$ and $\sigma((x_1, x_2)) = 2$ if $x_1 x_2 > 0$, i.e., when $x_1 x_2 \leq 0$, system (2.2.1) is activated, and, when $x_1 x_2 > 0$, system (2.2.2) is activated. While the individual subsystems (2.2.1) and (2.2.2) are both stable, the switched system given by them is unstable, as shown in Figures 2.1 and 2.2. \square

The idea behind Example 2.2.1 is well illustrated in Figure 2.3, where a system switching between two stable subsystems is shown to be unstable. Similarly, a system switching between two unstable subsystems could be stable, as shown in Figure 2.4. Based on these observations, the following can be concluded:

- ✦ Unconstrained switching can destabilize a switched system even if all the individual subsystems are stable.
- ✦ It is possible to stabilize a switched system by means of suitably constrained switching or designed switching even if all individual subsystems are unstable.

As one can imagine, when all the subsystems are stable, if we can make the switched systems stay in each of its stable subsystems for as long as possible, the possibility becomes large that the resulted switched system will be stable. This is the basic idea of stability of switched systems under slow switching and motivates the definitions of *dwell-time* and

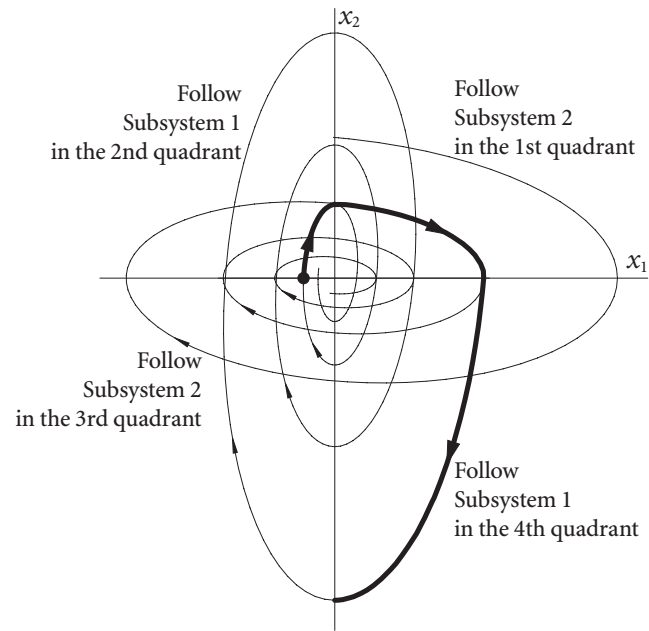

Figure 2.3 Switching between stable systems.

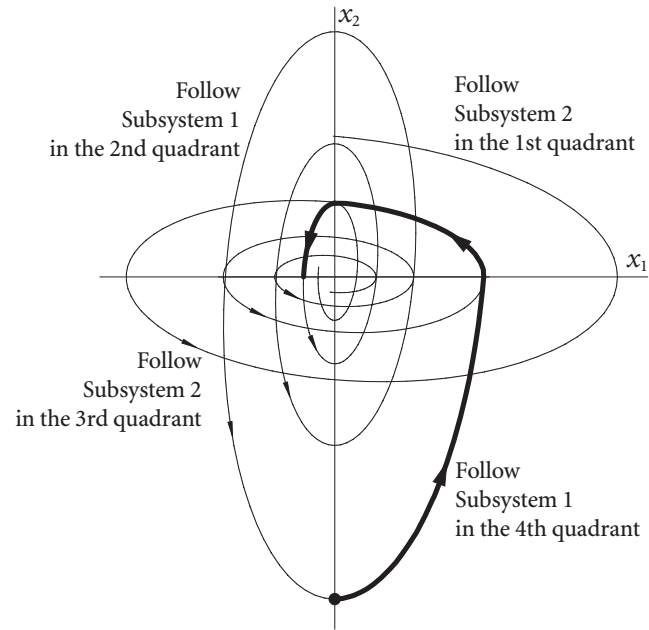

Figure 2.4 Switching between unstable systems.

average dwell-time [107]. However, this requires stability of all subsystems. When this is not the case, we are faced with the problem of finding a switching signal to stabilize the switched systems. Note that when there exists at least one stable subsystem, this problem is trivial since we can let the system dwell in the subsystem forever. However, this also assumes that we can arbitrarily choose our switching signal. If this can not be done, e.g., although some of the unstable subsystems are undesirable, they have to be activated for a certain amount of time to make the model practical. In this case, we still face a nontrivial problem. The last case is when all the subsystems are unstable, we have to design a switching rule to stabilize the switched systems. This also turns out to be a nontrivial matter. Thus one can approach the stability analysis of system (2.1.1) in the following three directions.

- I. Find conditions that guarantee stability of system (2.1.1) under arbitrary switching.
- II. Specify classes of switching signals under which system (2.1.1), with the presence of both stable and unstable subsystems, is uniformly stable.
- III. Design a particular switching signal to stabilize system (2.1.1) if none of its subsystems are stable.

We shall elaborate these three approaches in the following.

I. Stability under Arbitrary Switching

Lyapunov's second method has a direct extension which provides a basic tool for studying stability of the switched system (2.1.1). This extension requires the existence of a single Lyapunov function whose derivative along solutions of all subsystems of (2.1.1) satisfies suitable differential inequalities. This is known as the *common Lyapunov function* approach [107]. Following this approach, all the classical Lyapunov stability theorems can be extended to provide stability criteria for switched systems and the stability holds under arbitrary switching. We are not going to elaborate on this approach since it is essentially the same as the stability theory of ordinary differential equations.

II. Stability under Slow or Constrained Switching

Since different subsystems of a switched system may have very different structures, the differential inequalities imposed by a common Lyapunov function for all subsystems can become very restrictive. In such cases, a common Lyapunov function is usually hard to find or simply does not exist. A remedy for this is to introduce a useful tool called the *multiple*

Lyapunov functions method. Stability analysis of deterministic switched systems using multiple Lyapunov functions first appeared in [150] and has evolved over a series of articles (see, e.g., [20], [34], [74], [150]; see also [161] for a recent survey and references therein). It is well known that a switched system is stable if all individual subsystems are stable and the switching is sufficiently slow, so as to allow the transient effects to dissipate after each switch. To characterize slow switching, notions of dwell-time and average dwell-time have been proposed [107].

Dwell-Time Switching. Given $\tau > 0$, a switching signal is said to have *dwell-time* τ if

$$\inf \{t_{k+1} - t_k : k \in \mathcal{Z}^+\} \geq \tau. \quad (2.2.3)$$

The set of switching signals with dwell-time τ is denoted by $\mathcal{S}_{\text{inf}}(\tau)$. \square

Stability can be proved if all subsystems are stable and the switching signals have sufficiently large dwell-time. It turns out that specifying a dwell-time condition may be too restrictive since the (exponential) stability is an asymptotic property. We may allow the possibility of switching fast at some time and then compensating for it by switching sufficiently slowly later. The concept of average dwell-time from [68] serves this purpose.

Average Dwell-Time Switching. Given $\tau > 0$ and $N_0 > 0$, let $\mathcal{S}_a(\tau, N_0)$ denote the set of switching signals satisfying

$$N_\sigma(T, t) \leq N_0 + \frac{T - t}{\tau}, \quad \forall T \geq t \geq t_0, \quad (2.2.4)$$

where $N_\sigma(T, t)$ is the number of switching times of σ between t and T . This set of switching signals are said to have *average dwell-time* τ and chatter bound N_0 . \square

Clearly, $\mathcal{S}_{\text{inf}}(\tau) \subset \mathcal{S}_a(\tau, 1)$. Moreover, both dwell-time and average dwell-time switching signals have the properties of *finite switches in finite time*, i.e., have only a finite number of switching times within any bounded time interval. All switching signals with finite switches in finite time are denoted by \mathcal{S}_0 . It is shown in [68] that, if all the subsystems are stable, an autonomous switched system is stable under switching signals in $\mathcal{S}_a(\tau, N_0)$ for sufficiently large τ .

We shall pursue this approach later in Section 2.4 of this chapter in a broader sense that not all the subsystems have to be stable.

III. Stability under Designed Switching

There is another trend in the stability analysis of switched systems, i.e., one can choose a specified state-dependent switching signal to stabilize a family of systems with certain properties. In [182], Wick *et al.* considered a switched system consisting of two individual systems

$$\dot{x}(t) = A_1x(t) \quad \text{and} \quad \dot{x}(t) = A_2x(t),$$

where A_1 and A_2 are assumed to have a Hurwitz linear convex combination $\alpha A_1 + (1 - \alpha)A_2$ with $0 < \alpha < 1$. Under this assumption, they proved that a state-dependent switching rule can be constructed to stabilize the system.

We will elaborate this approach and extend it to the stability analysis of fully nonlinear switched systems in Section 2.5 of this chapter.

2.3 Comparison Functions, Multiple Lyapunov Functions, and Derivatives

Comparison functions, commonly known as class \mathcal{K} and class \mathcal{KL} functions, have been proved very useful in deriving uniform stability as well as input-to-state stability for nonlinear systems [90]. We introduce these two classes for the use in this and subsequent chapters.

Definition 2.3.1 A function $\alpha : \mathcal{R}^+ \rightarrow \mathcal{R}^+$ is said to be of **class \mathcal{K}** and we write $\alpha \in \mathcal{K}$, if α is continuous, strictly increasing, and $\alpha(0) = 0$. If $\alpha \in \mathcal{K}$ also satisfies $\alpha(t) \rightarrow \infty$ as $t \rightarrow \infty$, we say that α is of **class \mathcal{K}_∞** and write $\alpha \in \mathcal{K}_\infty$. A function $\beta : \mathcal{R}^+ \times \mathcal{R}^+ \rightarrow \mathcal{R}^+$ is said to be of **class \mathcal{KL}** and we write $\beta \in \mathcal{KL}$, if $\beta(\cdot, t)$ is of class \mathcal{K} for each $t \in \mathcal{R}^+$ and $\beta(r, t)$ decreases to 0 as $t \rightarrow \infty$ for each fixed $r \in \mathcal{R}^+$. \square

As mentioned in Section 2.2, the method of multiple Lyapunov functions provides a powerful tool for stability analysis of switched systems. By a family of multiple Lyapunov functions candidates, we mean a family of functions $\{V_i : i \in \mathcal{I}\}$. The classical Lyapunov stability analysis requires computing the derivative of a Lyapunov function candidate along the trajectories of the system under investigation. As for a switched system, we have to compute this derivative along the trajectories of each subsystems. We consider two cases.

Continuously Differentiable Lyapunov Functions. If $f_i \in C^1(\mathcal{R}^+ \times \mathcal{R}^n; \mathcal{R}^+)$, we define

$$\dot{V}_i(t, x) = \frac{\partial V_i}{\partial t}(t, x) + \frac{\partial V_i}{\partial x}(t, x) \cdot f_i(t, x) = \frac{\partial V_i}{\partial t}(t, x) + \sum_{d=1}^n \frac{\partial V_i}{\partial x_d}(t, x) f_{id}(t, x), \quad (2.3.1)$$

where \cdot means dot product in \mathcal{R}^n and $f_{id}(t, x)$ denotes the d th component of $f_i(t, x)$. \square

Locally Lipschitzian Lyapunov functions. If $f_i \in C(\mathcal{R}^+ \times \mathcal{R}^n; \mathcal{R}^+)$ and f_i is locally Lipschitz continuous in the second variable, we define

$$D^+ V_i(t, x) = \limsup_{h \rightarrow 0^+} \frac{1}{h} [V_i(t + h, x + hf_i(t, x)) - V_i(t, x)]. \quad (2.3.2)$$

Lipschitz continuity of f_i in x is needed to prove relation (2.3.3) below. \square

Remark 2.3.1 If there happens to be a common Lyapunov function V , equations (2.3.1) and (2.3.2) are understood as $V_i = V$ for all $i \in \mathcal{I}$ on the right-hand sides. \square

It is clear that, in either case, $\dot{V}_i(t, x)$ and $D^+ V_i(t, x)$ are dependent on the equation of the i th subsystem. Hence, $\dot{V}_i(t, x)$ and $D^+ V_i(t, x)$ will be different for different subsystems. The intuitive idea behind the Lyapunov stability analysis is that if $\dot{V}_i(t, x)$ or $D^+ V_i(t, x)$ is negative, then $V_i(t, x(t))$ will decrease along the solutions of the i th subsystem of (2.1.1), since both (2.3.1) and (2.3.2) yield the following relation

$$\dot{V}_i(t, x) = D^+ V_i(t, x) = \limsup_{h \rightarrow 0^+} \frac{1}{h} [V_i(t + h, x(t + h)) - V_i(t, x)], \quad (2.3.3)$$

where $x(t)$ is a solution of the i th subsystem of (2.1.1) on a small interval $[t, t + h]$ with $x(t) = x$. A proof for relation (2.3.3) is standard in the Lyapunov stability theory for ODEs (see, e.g., [197]).

2.4 Uniform Stability of Switched Nonlinear Systems

This section will be devoted to study the uniform stability, uniform asymptotic stability, and uniform exponential stability for nonautonomous switched nonlinear systems, where uniformity refers not only to the multiple solutions that one obtains as the switching signal ranges over a given admissible set, but also to the stability and convergence in the usual sense.

As mentioned in Section 2.2, several Lyapunov-like theorems are available for switched systems by employing multiple Lyapunov functions (see, e.g., [20], [41], [150], [152], [196]).

Particularly, the recent work of [104] investigated uniform asymptotic stability for general nonlinear and time-varying switched systems. The results are particularly useful in the sense that a generalized version of the celebrated Krasovskii-LaSalle theorem for general nonlinear and time-varying switched systems has been proposed. However, all of these results deal with only the case when all the subsystems of (2.1.1) are stable, which is often not the case in many practical hybrid control systems. For example, if one wants to control a hybrid system, it might be difficult and expensive to stabilize each of the subsystems. Therefore some control strategy can be taken to ensure stability of the switching control system by achieving a balance between the activation of the stable subsystems and unstable subsystems. This kind of balance condition will be the main issues to be addressed in this section for a general class of nonautonomous switched nonlinear subsystems.

The results in this section are partially inspired by the work of [199] on linear switched systems with both stable and unstable systems, as well as by the work of [69] on uniform stability of switched linear systems.

The remainder of this section is organized as follows. In Section 2.4.1, necessary notations and preliminaries are given so as to formulate the main problem. Uniform stability is discussed in Section 2.4.2, uniform asymptotic stability in Section 2.4.3, uniform exponential stability in Section 2.4.4, and stability of linear switched systems in Section 2.4.5. Several numerical examples are presented in Section 2.4.6.

2.4.1 Definitions of Uniform Stability

In this section, we focus exclusively on time-dependent switching signals¹. Let \mathcal{S}_0 denote the set of all (time-dependent) switching signals that are piecewise constant, continuous from the right, and have only a finite number of discontinuities over any finite time interval. To emphasize a set $\mathcal{S} \subset \mathcal{S}_0$ of switching signals, system (2.1.1) can be written as

$$\dot{x} = f_{\sigma}(t, x), \quad \sigma \in \mathcal{S}, \quad t \geq t_0. \quad (2.4.1)$$

A solution to the switched system (2.4.1) can then be interpreted as a pair (x, σ) such that $\sigma \in \mathcal{S}$ and $x : [t_0, \infty) \rightarrow \mathcal{R}^n$ solves the following time-varying system

$$\dot{x} = f_{\sigma(t)}(t, x), \quad t \geq t_0. \quad (2.4.2)$$

¹State-dependent switching signals can also be covered if the signals can be interpreted as time-dependent signals of the classes defined in this Section.

We will consider the case when system (2.4.1) has both stable and unstable subsystems. For this purpose, the index set \mathcal{I} is divided into two subsets \mathcal{I}_s and \mathcal{I}_u , where \mathcal{I}_s is used to index the stable subsystems and \mathcal{I}_u the unstable ones. With this partition of the index set, we can now introduce different sets of admissible switching signals which will be considered in this section. For any $\delta > 0$, let $\mathcal{S}_{\text{sup}}^u(\delta)$ denote the following

$$\mathcal{S}_{\text{sup}}^u(\delta) = \left\{ \sigma \in \mathcal{S}_0 : \sup_{\sigma(t_k) \in \mathcal{I}_u} (t_{k+1} - t_k) \leq \delta \right\}.$$

The idea behind defining $\mathcal{S}_{\text{sup}}^u(\delta)$ is that the switched system is not supposed to dwell on its unstable subsystems for overly long. To achieve a balance between the activation of unstable subsystems and stable subsystems, denote by $\pi_s(t)$ the total activation time of the stable subsystems and $\pi_u(t)$ the total activation time of the unstable subsystems on the time interval $[t_0, t]$. Clearly, to guarantee the switched system to be stable, the unstable subsystems are not supposed to be activated for very long compared to the stable subsystems. For this purpose, for some $r \geq 0$ and $T \geq t_0$, the set $\mathcal{S}(r, T)$ is defined as

$$\mathcal{S}(r, T) = \left\{ \sigma \in \mathcal{S}_0 : \frac{\pi_u(t)}{\pi_s(t)} \leq r, \forall t \geq T \right\}.$$

Moreover, for $\tau > 0$ and $N_0 > 0$, let $\mathcal{S}_a(\tau, N_0)$ denote the switching signals with average dwell-time τ and chatter bound N_0 as defined by (2.2.4).

Assume that $f_i(t, 0) \equiv 0$, for all $t \geq t_0$ and $i \in \mathcal{I}$, so that (2.4.1) has a trivial solution for all σ . Given a set of admissible switching signals \mathcal{S} , uniform stability for (2.4.1) over \mathcal{S} is defined as follows.

Definition 2.4.1 The switched system (2.4.1) is said to be **uniformly stable** (US) over \mathcal{S} if, given any $\varepsilon > 0$, there exists some $\rho = \rho(\varepsilon) > 0$, independent of t_0 and $\sigma \in \mathcal{S}$, such that $\|x(t_0)\| < \rho$ implies $\|x(t)\| < \varepsilon$, for (x, σ) with $\sigma \in \mathcal{S}$ that solves (2.4.1). \square

Definition 2.4.2 The switched system (2.4.1) is said to be **globally uniformly asymptotically stable** (GUAS) over \mathcal{S} if it is uniformly stable over \mathcal{S} and, for each pair of $\varepsilon > 0$ and $\eta > 0$, there exists some $T = T(\varepsilon, \eta)$, independent of t_0 and $\sigma \in \mathcal{S}$, such that $\|x(t_0)\| < \eta$ implies $\|x(t)\| < \varepsilon$, $\forall t \geq t_0 + T$, for (x, σ) with $\sigma \in \mathcal{S}$ that solves (2.4.1). \square

Definition 2.4.3 The switched system (2.4.1) is said to be **globally uniformly exponentially stable** (GUES) over \mathcal{S} if, given any $\varepsilon > 0$, there exist positive constants C and ε , independent

of t_0 and $\sigma \in \mathcal{S}$, such that

$$\|x(t)\| \leq C \|x(t_0)\| e^{-\varepsilon(t-t_0)}, \quad t \geq t_0,$$

for (x, σ) with $\sigma \in \mathcal{S}$ that solves (2.4.1). \square

The main problems studied in this section are to seek sufficient conditions such that system (2.4.1) is uniformly stable, uniformly asymptotically stable, and uniformly exponentially stable over a certain set of admissible switching signals. Note that we will only consider global stability to make the results easier to present. The global results can be easily adapted to obtain local ones.

We will assume in this chapter that the Lyapunov functions are continuously differentiable. Similar results can be easily proved by employing locally Lipschitzian Lyapunov functions and Dini derivatives [98] as defined by (2.3.2).

2.4.2 Uniform Stability

Consider $\{V_i : i \in \mathcal{I}\}$ as a candidate family of multiple Lyapunov functions. We stipulate the following assumption on the evolution of V_i over switching times, which is the same as that adopted in [20]. This assumption involves a set \mathcal{S} of admissible switching signals.

Assumption 2.4.1 Let (x, σ) be a pair with $\sigma \in \mathcal{S}$ that solves (2.4.1). For each $i \in \mathcal{I}$ and every pair of switching times $t_k < t_l$ such that $\sigma(t_k) = \sigma(t_l) = i$, we have

$$V_i(t_l, x(t_l)) \leq V_i(t_k, x(t_k)). \quad \square$$

Theorem 2.4.1 Suppose \mathcal{I} is a finite index set and there exist a family of continuous differentiable functions $\{V_i : i \in \mathcal{I}\}$ and functions $u, v \in \mathcal{K}$ such that

$$u(\|x\|) \leq V_i(t, x) \leq v(\|x\|), \quad \forall i \in \mathcal{I},$$

holds for all $t \geq t_0$ and $x \in \mathcal{R}^n$. Moreover,

$$\dot{V}_i(t, x) \leq \mu V_i(t, x), \quad \forall i \in \mathcal{I}_u,$$

and

$$\dot{V}_i(t, x) \leq 0, \quad \forall i \in \mathcal{I}_s,$$

hold for some $\mu \geq 0$, all $t \geq t_0$ and $x \in \mathcal{R}^n$. If, in addition, Assumption 2.4.1 holds over \mathcal{S} and $\mathcal{S} \subset \mathcal{S}_{\text{sup}}^u(\delta)$ for some $\delta > 0$, then system (2.4.1) is uniformly stable over \mathcal{S} .

Proof. Let N denote the cardinality of \mathcal{I} . Given any $\varepsilon > 0$, we can define positive numbers $\rho_1, \rho_2, \dots, \rho_N$ in the following manner. Denote $\rho_0 = \varepsilon$. Recursively, $\rho_j < \rho_{j-1}$ is found such that

$$v(\rho_j)e^{\mu\delta} < u(\rho_{j-1}) \quad (2.4.3)$$

for $j = 1, 2, \dots, N$. We claim that choosing $\rho = \rho_N$ shows uniform stability of (2.4.1). Clearly, this ρ is independent of t_0 and any particular choice of σ . It suffices to show that $\|x(t_0)\| < \rho$ implies $\|x(t)\| < \varepsilon$, where x together with some $\sigma \in \mathcal{S}$ solves (2.4.1).

Assume $\|x(t_0)\| \leq \rho$. We claim that

$$\|x(t)\| < \rho_{N-n}, \quad t \geq t_0, \quad (2.4.4)$$

where $n = n(t)$ is the number of subsystems that have been activated up to time t (not counting multiplicity). This claim would imply stability, since $\rho_i \leq \varepsilon$ for $0 \leq i \leq N$ and, clearly, n only takes values from 1 to N .

Proof of the Claim. The claim can be shown by induction. Bear in mind that $n(t)$ is a nondecreasing right-continuous function, which takes integer value from 1 to N . We complete the proof in three steps.

(i) We first show it holds for all t such that $n(t) = 1$, that is for $t \in [t_0, t_1)$, where t_1 is the first switching time for σ (if such a switching time does not exist, i.e., the switched system dwells on one subsystem forever, then let $t_1 = \infty$). Depending on whether the first subsystem activated is in \mathcal{I}_s or \mathcal{I}_u , two cases are discussed. If $\sigma(t_0) \in \mathcal{I}_s$, then conditions on $V_i, i \in \mathcal{I}_s$, imply that $V_{\sigma(t_0)}(t, x(t))$ is nonincreasing on $[t_0, t_1)$. It follows that

$$\begin{aligned} u(\|x(t)\|) &\leq V_{\sigma(t_0)}(t, x(t)) \leq V_{\sigma(t_0)}(t_0, x(t_0)) \leq v(\|x(t_0)\|) \\ &\leq v(\rho) < u(\rho_{N-1}), \quad \forall t \in [t_0, t_1), \end{aligned} \quad (2.4.5)$$

where the last inequality is given by (2.4.3). If $\sigma(t_0) \in \mathcal{I}_u$, then conditions on $V_i, i \in \mathcal{I}_u$, imply that

$$\dot{V}_{\sigma(t_0)}(t, x(t)) \leq \mu V_{\sigma(t_0)}(t, x(t)), \quad \forall t \in [t_0, t_1).$$

It follows that

$$V_{\sigma(t_0)}(t, x(t)) \leq V_{\sigma(t_0)}(t_0, x(t_0))e^{\mu(t-t_0)}, \quad \forall t \in [t_0, t_1).$$

Since $\sigma \in \mathcal{S} \subset \mathcal{S}_{\text{sup}}^u(\delta)$, we have $t_1 - t_0 \leq \delta$ and the previous inequality implies

$$V_{\sigma(t_0)}(t, x(t)) \leq V_{\sigma(t_0)}(t_0, x(t_0))e^{\mu\delta}, \quad \forall t \in [t_0, t_1].$$

Conditions on $V_i, i \in \mathcal{I}$, further imply that, $\forall t \in [t_0, t_1)$,

$$\begin{aligned} u(\|x(t)\|) &\leq V_{\sigma(t_0)}(t, x(t)) \leq V_{\sigma(t_0)}(t_0, x(t_0))e^{\mu\delta} \\ &\leq v(\|x(t_0)\|)e^{\mu\delta} \leq v(\rho)e^{\mu\delta} < u(\rho_{N-1}), \end{aligned} \quad (2.4.6)$$

where the last inequality is still given by (2.4.3). Now either (2.4.5) or (2.4.6) implies $\|x(t)\| < \rho_{N-1}$ for $t \in [t_0, t_1)$. The claim is shown for all t such that $n(t) = 1$.

(ii) Now assume that the claim is proved for all t such that $n(t) \leq k$, where $k \leq N$. If $k = N$, then the claim is already proved since $n(t) \leq N$ for all $t \geq t_0$. If $k \leq N - 1$ and $n(t) \leq k$ for all $t \geq t_0$, then the claim is also proved. Thus we can assume $k \leq N - 1$ and there exists a switching time t_m of σ such that $n(t_m) = k + 1$, i.e., some subsystem that is not activated before is now activated at $t = t_m$ for the first time.

(iii) We proceed to show that $\|x(t)\| < \rho_{N-k-1}$ for all t such that $n(t) = k + 1$. Assume the next switching time beyond t_m is t_{m+1} ; if t_{m+1} does not exist, take $t_{m+1} = \infty$. Then $n(t) \equiv k + 1$ on $[t_m, t_{m+1})$. We want to show $\|x(t)\| < \rho_{N-k-1}$ for $t \in [t_m, t_{m+1})$. Since for $t < t_m$, we have $\|x(t)\| < \rho_{N-k}$ by the inductive assumption, it follows that $\|x(t_m)\| \leq \rho_{N-k}$ by continuity. We can use the same argument as we did on $[t_0, t_1)$. Then (2.4.5) and (2.4.6) become

$$\begin{aligned} u(\|x(t)\|) &\leq V_{\sigma(t_m)}(t, x(t)) \leq V_{\sigma(t_m)}(t_m, x(t_m)) \\ &\leq v(\|x(t_m)\|) \leq v(\rho_{N-k}) \\ &< u(\rho_{N-k-1}), \quad \forall t \in [t_m, t_{m+1}), \end{aligned} \quad (2.4.7)$$

and

$$\begin{aligned} u(\|x(t)\|) &\leq V_{\sigma(t_m)}(t, x(t)) \leq V_{\sigma(t_m)}(t_m, x(t_m))e^{\mu\delta} \\ &\leq v(\|x(t_m)\|)e^{\mu\delta} \leq v(\rho_{N-k})e^{\mu\delta} \\ &< u(\rho_{N-k-1}), \quad \forall t \in [t_m, t_{m+1}), \end{aligned} \quad (2.4.8)$$

both of which imply $\|x(t)\| < \rho_{N-k-1}$ for $t \in [t_m, t_{m+1})$. If $n(t_{m+1}) = k + 2$, then we have already shown $\|x(t)\| < \rho_{N-k-1}$ for all t such that $n(t) = k + 1$; if $n(t)$ remains $k + 1$ on

$[t_{m+1}, t_{m+2})$, where t_{m+2} is the next switching time beyond t_{m+1} , then some subsystem, say the i th one, activated once before is activated again at $t = t_{m+1}$. Let $t_{m'} < t_{m+1}$ be the first switching time such that $\sigma(t_{m'}) = \sigma(t_{m+1}) = i$. Then since, $n(t) \leq k$ for $t < t_{m'}$, it follows that

$$\|x(t_{m'})\| \leq \rho_{N-k}, \quad (2.4.9)$$

by the inductive assumption and continuity of $x(t)$. Now by Assumption 2.4.1, we have

$$V_{\sigma(t_{m+1})}(t_{m+1}, x(t_{m+1})) \leq V_{\sigma(t_{m'})}(t_{m'}, x(t_{m'})). \quad (2.4.10)$$

Applying the same argument on $[t_{m+1}, t_{m+2})$ as we did on $[t_0, t_1)$ and by virtue of (2.4.9) and (2.4.10), we have, analogous to (2.4.5) and (2.4.6), either

$$\begin{aligned} u(\|x(t)\|) &\leq V_{\sigma(t_{m+1})}(t, x(t)) \leq V_{\sigma(t_{m+1})}(t_{m+1}, x(t_{m+1})) \\ &\leq V_{\sigma(t_{m'})}(t_{m'}, x(t_{m'})) \leq v(\|x(t_{m'})\|) \leq v(\rho_{N-k}) \\ &< u(\rho_{N-k-1}), \quad \forall t \in [t_{m+1}, t_{m+2}), \end{aligned} \quad (2.4.11)$$

or

$$\begin{aligned} u(\|x(t)\|) &\leq V_{\sigma(t_{m+1})}(t, x(t)) \leq V_{\sigma(t_{m+1})}(t_{m+1}, x(t_{m+1})) \\ &\leq V_{\sigma(t_{m'})}(t_{m'}, x(t_{m'}))e^{\mu\delta} \leq v(\|x(t_{m'})\|)e^{\mu\delta} \\ &\leq v(\rho_{N-k})e^{\mu\delta} \\ &< u(\rho_{N-k-1}), \quad \forall t \in [t_{m+1}, t_{m+2}). \end{aligned} \quad (2.4.12)$$

In either case, it follows that $\|x(t)\| < \rho_{N-k-1}$ for $t \in [t_{m+1}, t_{m+2})$. This argument can be repeated until some switching time $t_{m''}$ is found such that $n(t_{m''}) = k + 2$. If no such $t_{m''}$ exists, then $n(t) \leq k + 1$ for all $t \geq t_0$, and (2.4.11) and (2.4.12) can show $\|x(t)\| < \rho_{N-k-1}$ for all t such that $n(t) = k + 1$. By induction, $\|x(t)\| < \rho_{N-k}$ for all t such that $n(t) = k$, where $1 \leq k \leq N$. The claim of (2.4.4) is now proved and uniform stability of (2.4.1) follows. \square

Remark 2.4.1 Based on the proof of Theorem 2.4.1, it can be seen that Assumption 2.4.1 can actually be replaced by the following weaker one: for each $i \in \mathcal{I}$ and every pair of switching times $t_i < t_j$ such that $\sigma(t_i) = \sigma(t_j) = i$ and t_i is the first time the i th subsystem is activated, we have

$$V_i(t_j, x(t_j)) \leq V_i(t_i, x(t_i)). \quad (2.4.13)$$

\square

Remark 2.4.2 As a special case when $\mathcal{I}_u = \emptyset$, i.e., there exist no unstable subsystems, and system (2.4.1) is autonomous, Theorem 2.4.1 reduces to Theorem 2.3 in [20]. Even in this special case, if one considers the built-in “uniformity” notion and the weaker assumption (2.4.13), Theorem 2.4.1 is a slight improvement over the results in [20]. \square

Remark 2.4.3 However, it should definitely be noted that Assumption 2.4.1, even in its weaker form (2.4.13), remains quite strong an assumption in the case when unstable subsystems are present. In applications, for the assumption to hold, we usually need a certain decay rate of the stable subsystems and require that the stable subsystems are activated for a sufficient amount of time while the unstable systems are only activated for an allowable amount of time. This will be addressed in further details shortly when we discuss the asymptotic stability of system (2.4.1) in Section (2.4.3), where Assumption 2.4.1 is absent and only a certain balance of the total activation time of stable subsystems and unstable subsystems is required. \square

Remark 2.4.4 As mentioned in [20] and [69], in hybrid control systems, the switching signal σ is often generated by a supervisory logic (“higher process”) that guarantees, by construction, that assumptions such as Assumption 2.4.1 or (2.4.13) hold. \square

2.4.3 Uniform Asymptotic Stability

The following lemma is useful to prove asymptotic stability. To present the lemma, some more notations are in order. Let $\mathcal{U}(t)$ be a piecewise continuous function on $[t_0, T]$ with t_1, t_2, \dots, t_N as discontinuities. Assume $\mathcal{U}(t)$ is right-continuous over these discontinuities. Let $\mathcal{I}_\mu(T)$ and $\mathcal{I}_\lambda(T)$ be two collections of intervals such that $\mathcal{I}_\mu(T) \cap \mathcal{I}_\lambda(T) = \emptyset$ and

$$\mathcal{I}_\mu(T) \cup \mathcal{I}_\lambda(T) = \mathcal{I}(T) = \{[t_0, t], [t_1, t_2], \dots, [t_N, T]\}.$$

Denote

$$\pi_\mu(T) = \sum_{I \in \mathcal{I}_\mu} |I|,$$

and

$$\pi_\lambda(T) = \sum_{I \in \mathcal{I}_\lambda} |I|,$$

where $|I|$ denotes the length of interval I . It is easy to see that $\pi_\mu(T)$ and $\pi_\lambda(T)$ are both continuous in T . Moreover, the trivial identity $\pi_\mu(T) + \pi_\lambda(T) = T - t_0$ holds. By $\mathcal{U}(t^-)$ we mean $\lim_{s \rightarrow t^-} \mathcal{U}(s)$.

Lemma 2.4.1 *If $\mathcal{U}(t)$ satisfies*

$$\dot{\mathcal{U}}(t) \leq \mu \mathcal{U}(t), \quad \forall t \in I \in \mathcal{I}_\mu(T),$$

$$\dot{\mathcal{U}}(t) \leq -\lambda \mathcal{U}(t), \quad \forall t \in I \in \mathcal{I}_\lambda(T),$$

for some $\mu, \lambda \geq 0$, and

$$\mathcal{U}(t_i) \leq \rho \mathcal{U}(t_i^-), \quad 1 \leq i \leq N, \quad (2.4.14)$$

for some $\rho \geq 0$, then

$$\mathcal{U}(T) \leq \mathcal{U}(t_0) \rho^N e^{\mu \pi_\mu(T) - \lambda \pi_\lambda(T)}. \quad (2.4.15)$$

Proof. We show (2.4.15) by induction. If $N = 0$, then clearly either $\mathcal{I}_\mu(T) = \emptyset$ or $\mathcal{I}_\lambda(T) = \emptyset$. Assuming $\mathcal{I}_\lambda(T) = \emptyset$, we have

$$\dot{\mathcal{U}}(t) \leq \mu \mathcal{U}(t), \quad \forall t \in [t_0, T],$$

which immediately gives

$$\mathcal{U}(T) \leq \mathcal{U}(t_0) e^{\mu(T-t_0)}. \quad (2.4.16)$$

In light of the fact that $\pi_\mu(T) = T - t_0$ and $\pi_\lambda(T) = 0$, (2.4.16) proves (2.4.15) for $N = 0$. The proof for the case $\mathcal{I}_\mu(T) = \emptyset$ is exactly the same.

Now we assume (2.4.15) is true for $N = k$. We proceed to show that (2.4.16) holds for $N = k + 1$. For any $t \in [t_k, t_{k+1})$, the inductive assumption actually implies

$$\mathcal{U}(t) \leq \mathcal{U}(t_0) \rho^k e^{\mu \pi_\mu(t) - \lambda \pi_\lambda(t)}. \quad (2.4.17)$$

Letting $t \rightarrow t_{k+1}^-$, (2.4.17) gives

$$\mathcal{U}(t_{k+1}^-) \leq \mathcal{U}(t_0) \rho^k e^{\mu \pi_\mu(t_{k+1}) - \lambda \pi_\lambda(t_{k+1})}. \quad (2.4.18)$$

By (2.4.14) and (2.4.18), we have

$$\mathcal{U}(t_{k+1}) \leq \mathcal{U}(t_0) \rho^{k+1} e^{\mu \pi_\mu(t_{k+1}) - \lambda \pi_\lambda(t_{k+1})}. \quad (2.4.19)$$

Now consider the interval $[t_{k+1}, T]$. Assume $[t_{k+1}, T] \in I_\mu(T)$ first. Then we have

$$\dot{\mathcal{U}}(t) \leq \mu \mathcal{U}(t), \quad \forall t \in [t_{k+1}, T],$$

which immediately shows

$$\mathcal{U}(T) \leq \mathcal{U}(t_{k+1}) e^{\mu(T-t_{k+1})}. \quad (2.4.20)$$

In light of the fact, implied by $[t_{k+1}, T] \in I_\mu(T)$, that $\pi_\mu(T) = \pi_\mu(t_{k+1}) + (T - t_{k+1})$ and $\pi_\lambda(T) = \pi_\lambda(t_{k+1})$, (2.4.15) for $N = k + 1$ follows from (2.4.19) and (2.4.20). By induction, (2.4.15) holds for all N and the proof is complete. \square

Theorem 2.4.2 *Suppose there exist a family of continuous differentiable functions $\{V_i : i \in \mathcal{I}\}$ and functions $u, v \in \mathcal{K}_\infty$ such that*

$$u(\|x\|) \leq V_i(t, x) \leq v(\|x\|), \quad \forall i \in \mathcal{I}, \quad (2.4.21)$$

holds for all $t \geq t_0$ and $x \in \mathcal{R}^n$. Moreover, for some $\mu \geq 0$ and $\lambda > 0$,

$$\dot{V}_i(t, x) \leq \mu V_i(t, x), \quad \forall i \in \mathcal{I}_u,$$

$$\dot{V}_i(t, x) \leq -\lambda V_i(t, x), \quad \forall i \in \mathcal{I}_s,$$

for all $t \geq t_0$ and $x \in \mathcal{R}^n$, and

$$V_i(t, x) \leq \rho V_j(t, x), \quad \forall i, j \in \mathcal{I}, \quad (2.4.22)$$

for some $\rho \geq 1$, all $t \geq t_0$ and $x \in \mathcal{R}^n$. Then system (2.4.1) is globally uniformly asymptotically stable over \mathcal{S} , provided that $\mathcal{S} \subset \mathcal{S}(r, T) \cap \mathcal{S}_a(\tau, N_0)$ for some $T \geq t_0$ with

$$\frac{\ln \rho}{\tau} + \frac{\mu r - \lambda}{1 + r} < 0. \quad (2.4.23)$$

Proof. Given $\sigma \in \mathcal{S}$, consider $V_{\sigma(t)}(t, x)$ as a candidate for multiple Lyapunov functions. Let

$$\mathcal{U}(t) = V_{\sigma(t)}(t, x(t)),$$

where (x, σ) is a solution to (2.4.1). Then $\mathcal{U}(t)$ is a piecewise continuous function on $[t_0, \infty)$. We proceed to give an estimate for $\mathcal{U}(t)$ on $[t_0, \infty)$.

First, we consider $\mathcal{U}(t)$ on $[t_0, T]$. Let t_1, t_2, \dots, t_{n_0} be the switching times on $[t_0, t]$ with $t \in [t_0, T]$. Since $\sigma \in \mathcal{S}_a(\tau, N_0)$,

$$n_0 \leq N_0 + \frac{t - t_0}{\tau} \leq N_0 + \frac{T}{\tau} = c.$$

Although this upper bound c of n_0 depends on τ , T , and N_0 , it is independent of a particular choice of σ . Put $t_{N+1} = t$ and define

$$\mathcal{I}_\mu(t) = \bigcup_{\sigma(t_i) \in \mathcal{I}_u} \{[t_i, t_{i+1}]\},$$

and

$$\mathcal{I}_\lambda(t) = \bigcup_{\sigma(t_i) \in \mathcal{I}_s} \{[t_i, t_{i+1}]\}.$$

Then

$$\pi_u(t) = \pi_\mu(t), \quad \pi_s(t) = \pi_\lambda(t).$$

Since $\mathcal{U}(t)$ satisfies all the assumptions of Lemma 2.4.1, we can apply Lemma 2.4.1 and obtain

$$\begin{aligned} \mathcal{U}(t) &\leq \mathcal{U}(t_0) \rho^{n_0} e^{\mu\pi_s(t) - \lambda\pi_u(t)} \\ &\leq \mathcal{U}(t_0) \rho^c e^{\mu\pi_s(t) + \mu\pi_u(t)} \\ &\leq \mathcal{U}(t_0) \rho^c e^{\mu(t-t_0)} \\ &\leq \mathcal{U}(t_0) \rho^c e^{\mu T}, \quad \forall t \in [t_0, T], \end{aligned} \tag{2.4.24}$$

where we have used the fact that $\mu \geq 0 \geq \lambda$ and $\pi_s(t) + \pi_u(t) = t - t_0$.

Second, we consider $\mathcal{U}(t)$ on $[T, \infty)$. Let t_1, t_2, \dots, t_N be the switching times on $[t_0, t]$ with $t \in [T, \infty)$. Since $\sigma \in \mathcal{S}_a(\tau, N_0)$, we have

$$N \leq N_0 + \frac{t - t_0}{\tau}.$$

Moreover, $\sigma \in \mathcal{S}(r, T)$ gives

$$\pi_u(t) \leq r\pi_s(t),$$

which together with the identity $\pi_s(t) + \pi_u(t) = t - t_0$ yields

$$\pi_s(t) \geq \frac{t - t_0}{1 + r}.$$

Then by Lemma 2.4.1 and (2.4.23), we have

$$\begin{aligned} \mathcal{U}(t) &\leq \mathcal{U}(t_0) \rho^N e^{\mu\pi_u(t) - \lambda\pi_s(t)} \\ &\leq \mathcal{U}(t_0) \rho^{N_0 + \frac{t-t_0}{\tau}} e^{(\mu r - \lambda)\pi_s(t)} \\ &\leq \mathcal{U}(t_0) \rho^{N_0} e^{\frac{t-t_0}{\tau} \ln \rho + (\mu r - \lambda) \frac{t-t_0}{1+r}} \\ &\leq \mathcal{U}(t_0) \rho^{N_0} e^{\left(\frac{\ln \rho}{\tau} + \frac{\mu r - \lambda}{1+r}\right)(t-t_0)}, \quad \forall t \in [T, \infty). \end{aligned} \tag{2.4.25}$$

Based on (2.4.24) and (2.4.25), we can now show uniform asymptotic stability of (2.4.1) by definition. We first show uniform stability. Given any $\varepsilon > 0$, choose $\delta > 0$ such that

$$v(\delta)\rho^c e^{\mu T} < u(\varepsilon). \quad (2.4.26)$$

Then inequality (2.4.21), together with (2.4.24) and (2.4.25), gives

$$u(\|x(t)\|) \leq v(\|x(t_0)\|)\rho^c e^{\mu T}, \quad \forall t \in [t_0, \infty), \quad (2.4.27)$$

where $N_0 \leq c, \mu T \geq 0$, and (2.4.23) has been used. Now if $\|x(t_0)\| < \delta$, then, by (2.4.26) and (2.4.27), we have

$$u(\|x(t)\|) < v(\|\delta\|)\rho^c e^{\mu T} < u(\varepsilon), \quad \forall t \in [t_0, \infty),$$

which shows $\|x(t)\| < \varepsilon$ for all $t \geq t_0$. Since δ is independent of σ and t_0 , this proves uniform stability.

We can now show uniform convergence. Given any pair of $\varepsilon > 0$ and $\eta > 0$, and assuming $\|x(t_0)\| \leq \eta$, the estimate (2.4.27) and the fact that $u(r) \rightarrow \infty$ as $r \rightarrow \infty$ show that $x(t)$ is bounded for all $t \geq t_0$. This guarantees the global existence of solutions with a given σ . Now from (2.4.21) and (2.4.25), we have

$$u(\|x(t)\|) < v(\eta)\rho^{N_0} e^{\left(\frac{\ln \rho}{\tau} + \frac{\mu r - \lambda}{1+r}\right)(t-t_0)}, \quad \forall t \in [T, \infty). \quad (2.4.28)$$

Clearly, by (2.4.23), inequality (2.4.28) implies that there exists some T_0 , depending on ε and η , but independent of t_0 and σ , such that

$$u(\|x(t)\|) < v(\eta)\rho^{N_0} e^{\left(\frac{\ln \rho}{\tau} + \frac{\mu r - \lambda}{1+r}\right)(t-t_0)} < u(\varepsilon), \quad \forall t \geq t_0 + T_0,$$

which implies

$$\|x(t)\| < \varepsilon, \quad \forall t \geq t_0 + T_0,$$

as required. The proof is complete. \square

Remark 2.4.5 As a special case when there are no unstable subsystems present, we have $\mathcal{I}_s = \mathcal{I}$ and therefore $\mathcal{S}_a(\tau, N_0) \subset \mathcal{S}(r, T)$ for $r = 0$. Then (2.4.23) becomes $\tau > \frac{\ln \rho}{\lambda}$ and Theorem 2.4.2 gives the same results as [34, Theorem 2.12]. \square

Remark 2.4.6 When one employs a single common Lyapunov function, then (2.4.22) is trivially satisfied with $\rho = 1$. Since $\rho = 1$, the estimate (2.4.28) becomes

$$u(\|x(t)\|) < v(\eta)e^{\frac{\mu r - \lambda}{1+r}(t-t_0)}.$$

Therefore, (2.4.23) reduces to

$$\mu r - \lambda < 0. \quad (2.4.29)$$

Moreover, since no average dwell-time conditions are imposed, system (2.4.1) is GUAS over $\mathcal{S} \subset \mathcal{S}(r, T)$, provided that (2.4.29) holds. \square

2.4.4 Uniform Exponential Stability

Theorem 2.4.3 *Suppose there exist a family of continuous differentiable functions $\{V_i : i \in \mathcal{I}\}$ and positive constants c_1, c_2 such that*

$$c_1 \|x\|^2 \leq V_i(t, x) \leq c_2 \|x\|^2, \quad \forall i \in \mathcal{I}, \quad (2.4.30)$$

holds for all $t \geq t_0$ and $x \in \mathcal{R}^n$. Moreover, for some $\mu \geq 0$ and $\lambda > 0$,

$$\dot{V}_i(t, x) \leq \mu V_i(t, x), \quad \forall i \in \mathcal{I}_u, \quad (2.4.31)$$

$$\dot{V}_i(t, x) \leq -\lambda V_i(t, x), \quad \forall i \in \mathcal{I}_s, \quad (2.4.32)$$

for all $t \geq t_0$ and $x \in \mathcal{R}^n$, and

$$V_i(t, x) \leq \rho V_j(t, x), \quad \forall i, j \in \mathcal{I}, \quad (2.4.33)$$

for some $\rho \geq 1$, all $t \geq t_0$ and $x \in \mathcal{R}^n$. Then system (2.4.1) is globally uniformly exponentially stable over \mathcal{S} , provided that $\mathcal{S} \subset \mathcal{S}(r, T) \cap \mathcal{S}_a(\tau, N_0)$ for some $T \geq t_0$ with

$$\frac{\ln \rho}{\tau} + \frac{\mu r - \lambda}{1 + r} < 0. \quad (2.4.34)$$

Proof. In the proof for Theorem 2.4.2, two estimates are obtained as

$$\mathcal{U}(t) \leq \mathcal{U}(t_0) \rho^c e^{\mu T}, \quad \forall t \in [t_0, T], \quad (2.4.35)$$

and

$$\mathcal{U}(t) \leq \mathcal{U}(t_0) \rho^{N_0} e^{\left(\frac{\ln \rho}{\tau} + \frac{\mu r - \lambda}{1 + r}\right)(t - t_0)}, \quad \forall t \in [T, \infty), \quad (2.4.36)$$

where $N_0 \leq c$ and c is independent of t_0 and σ , and

$$\mathcal{U}(t) = V_{\sigma(t)}(t, x(t)).$$

Putting

$$\frac{\ln \rho}{\tau} + \frac{\mu r - \lambda}{1 + r} = -\varepsilon,$$

then ε is positive and independent of t_0 and σ . We claim that

$$\mathcal{U}(t) \leq C_0 \mathcal{U}(t_0) e^{-\varepsilon(t-t_0)}, \quad \forall t \geq t_0, \quad (2.4.37)$$

with

$$C_0 = \rho^c e^{(\mu+\varepsilon)T}.$$

Actually, on $[t_0, T]$, (2.4.35) shows

$$\begin{aligned} \mathcal{U}(t) &\leq \mathcal{U}(t_0) \rho^c e^{\mu T} \leq \rho^c e^{(\mu+\varepsilon)T} \mathcal{U}(t_0) e^{-\varepsilon T} \\ &\leq C_0 \mathcal{U}(t_0) e^{-\varepsilon(t-t_0)}. \end{aligned} \quad (2.4.38)$$

Moreover, on $[T, \infty)$, (2.4.36) immediately gives

$$\mathcal{U}(t) \leq \mathcal{U}(t_0) \rho^{N_0} e^{-\varepsilon(t-t_0)} \leq C_0 \mathcal{U}(t_0) e^{-\varepsilon(t-t_0)},$$

since $\rho^{N_0} \leq C_0$. Now (2.4.37) together with (2.4.30) gives

$$\begin{aligned} \|x(t)\| &\leq \sqrt{\frac{c_2}{c_1} C_0} \|x(t_0)\| e^{-\frac{1}{2}\varepsilon(t-t_0)} \\ &= C \|x(t_0)\| e^{-\frac{1}{2}\varepsilon(t-t_0)}, \quad \forall t \geq t_0, \end{aligned} \quad (2.4.39)$$

where $C = \sqrt{\frac{c_2}{c_1} C_0}$ is independent of t_0 and σ . It follows from (2.4.39) that (2.4.1) is GUES over $\mathcal{S} \subset \mathcal{S}(r, T) \cap \mathcal{S}_a(\tau, N_0)$. \square

Remark 2.4.7 According to (2.4.39), when the assumptions of Theorem 2.4.3 are satisfied, then the switched system has an exponential decay rate of no less than $\frac{\varepsilon}{2}$, where

$$\varepsilon = \frac{1}{2} \left(\frac{\ln \rho}{\tau} + \frac{\mu r - \lambda}{1 + r} \right).$$

2.4.5 Uniform Stability of Switched Linear Systems

Now let us consider the case when (2.4.1) is linear, i.e., the switched system

$$\dot{x} = A_\sigma x, \quad \sigma \in \mathcal{S}, \quad t \geq 0, \quad (2.4.40)$$

where $\sigma : [0, \infty) \rightarrow \mathcal{I}$ is the switching signal. The family $\{A_i : i \in \mathcal{I}\}$ of $n \times n$ matrices consists of a subfamily of Hurwitz stable subsystems $\{A_i : i \in \mathcal{I}_s\}$ and a subfamily of

Hurwitz unstable subsystems $\{A_i : i \in \mathcal{I}_u\}$. Assume that there exist a family of positive definite symmetric matrices $\{Q_i : i \in \mathcal{I}\}$ such that

$$A_i^T Q_i + Q_i A_i \leq -\lambda Q_i, \quad \forall i \in \mathcal{I}_s, \quad (2.4.41)$$

and

$$A_i^T Q_i + Q_i A_i \leq \mu Q_i, \quad \forall i \in \mathcal{I}_u, \quad (2.4.42)$$

for some $\lambda > 0$ and $\mu \geq 0$. Moreover, there exists some constant $\rho \geq 1$ such that

$$Q_i \leq \rho Q_j, \quad \forall i, j \in \mathcal{I}. \quad (2.4.43)$$

The following theorem can be seen as a corollary of Theorem 2.4.3.

Theorem 2.4.4 *System (2.4.40) is globally uniformly exponentially stable over \mathcal{S} , provided that $\mathcal{S} \subset \mathcal{S}(r, T) \cap \mathcal{S}_a(\tau, N_0)$ for some $T \geq t_0$ with*

$$\frac{\ln \rho}{\tau} + \frac{\mu r - \lambda}{1 + r} < 0. \quad (2.4.44)$$

Proof. Define $V_i(x) = x^T Q_i x$. It is easy to see that the family $\{V_i : i \in \mathcal{I}\}$ satisfies all the assumptions of Theorem 2.4.3. Actually, (2.4.41), (2.4.42), and (2.4.43) imply (2.4.31), (2.4.32), and (2.4.33), respectively. GUES of (2.4.40) is guaranteed by Theorem 2.4.3. \square

Remark 2.4.8 Theorem 2.4.4 can be easily applied by an LMIs (linear matrix inequalities) based approach. Suppose we have in mind a desired average dwell-time τ and a minimal ratio of activation time of the unstable subsystems r , we can start from (2.4.44) and let μ, λ, ρ be any numbers such that (2.4.44) is satisfied. Then we can seek solutions of the LMIs (2.4.41), (2.4.42), and (2.4.43). If such solutions exist, then we can claim exponential stability of the switched system under the desired switching signals. \square

2.4.6 Examples

Example 2.4.1 Consider the switched system (2.4.1) with $\mathcal{I} = \{1, 2\}$ and

$$f_1(t, x) = x \sin^2 t, \quad f_2(t, x) = -xt.$$

Stability Analysis. Construct a common Lyapunov function $V = \frac{1}{2}x^2$. Then

$$\dot{V}_1(x) = x^2 \sin^2 t \leq 2V(x),$$

and

$$\dot{V}_2(x) = -x^2 t \leq 0.$$

By Theorem 2.4.1, the system will be uniformly stable on any \mathcal{S} such that $\mathcal{S} \subset \mathcal{S}_{\text{sup}}^u(\delta)$ for some $\delta > 0$ and Assumption 2.4.1 or (2.4.13) holds. \square

Example 2.4.2 Consider the switched system (2.4.1) with $\mathcal{I} = \{1, 2\}$ and

$$f_1(t, x) = \begin{Bmatrix} -x_1 + x_2^3 \\ -x_2 - x_1 x_2^2 \end{Bmatrix}, \quad f_2(t, x) = \begin{Bmatrix} 2x_1 + x_1 x_2 \\ 2x_2 - x_1^2 \end{Bmatrix}.$$

Stability Analysis. Choose $V(x) = x_1^2 + x_2^2$ as a common Lyapunov function candidate. Then

$$\begin{aligned} \dot{V}_1(x) &= 2x_1 \dot{x}_1 + 2x_2 \dot{x}_2 = 2x_1(-x_1 + x_2^3) + 2x_2(-x_2 - x_1 x_2^2) \\ &= -2V(x), \end{aligned}$$

and

$$\begin{aligned} \dot{V}_2(x) &= 2x_1 \dot{x}_1 + 2x_2 \dot{x}_2 = 2x_1(2x_1 + x_1 x_2) + 2x_2(2x_2 - x_1^2) \\ &= 4V(x), \end{aligned}$$

One can choose $\mu = 4$ and $\lambda = 2$ and apply Theorem 2.4.2. According to Theorem 2.4.3 and Remark 2.4.6, system (2.4.1) is uniformly exponentially stable over $\mathcal{S} \subset \mathcal{S}(r, T)$ for any $T \geq t_0$ provided that $r < \frac{1}{2}$.

Simulation. (i) In order that system (2.4.1) is stable, we can activate subsystem 1 and subsystem 2 for time periods of 2.1 and 0.9, respectively, e.g., we can choose the following switching signal

$$\sigma_1(t) = \begin{cases} 1, & t \in [3k, 3k + 2.1), k \in \mathbb{Z}^+, \\ 2, & t \in [3k + 2.1, 3k + 3), k \in \mathbb{Z}^+. \end{cases} \quad (2.4.45)$$

Figure 2.5 shows the simulation results for this particular switching signal.

(ii) To show our results are tight, define the following switching signal

$$\sigma_2(t) = \begin{cases} 1, & t \in [3k, 3k + 2), k \in \mathbb{Z}^+, \\ 2, & t \in [3k + 2, 3k + 3), k \in \mathbb{Z}^+. \end{cases} \quad (2.4.46)$$

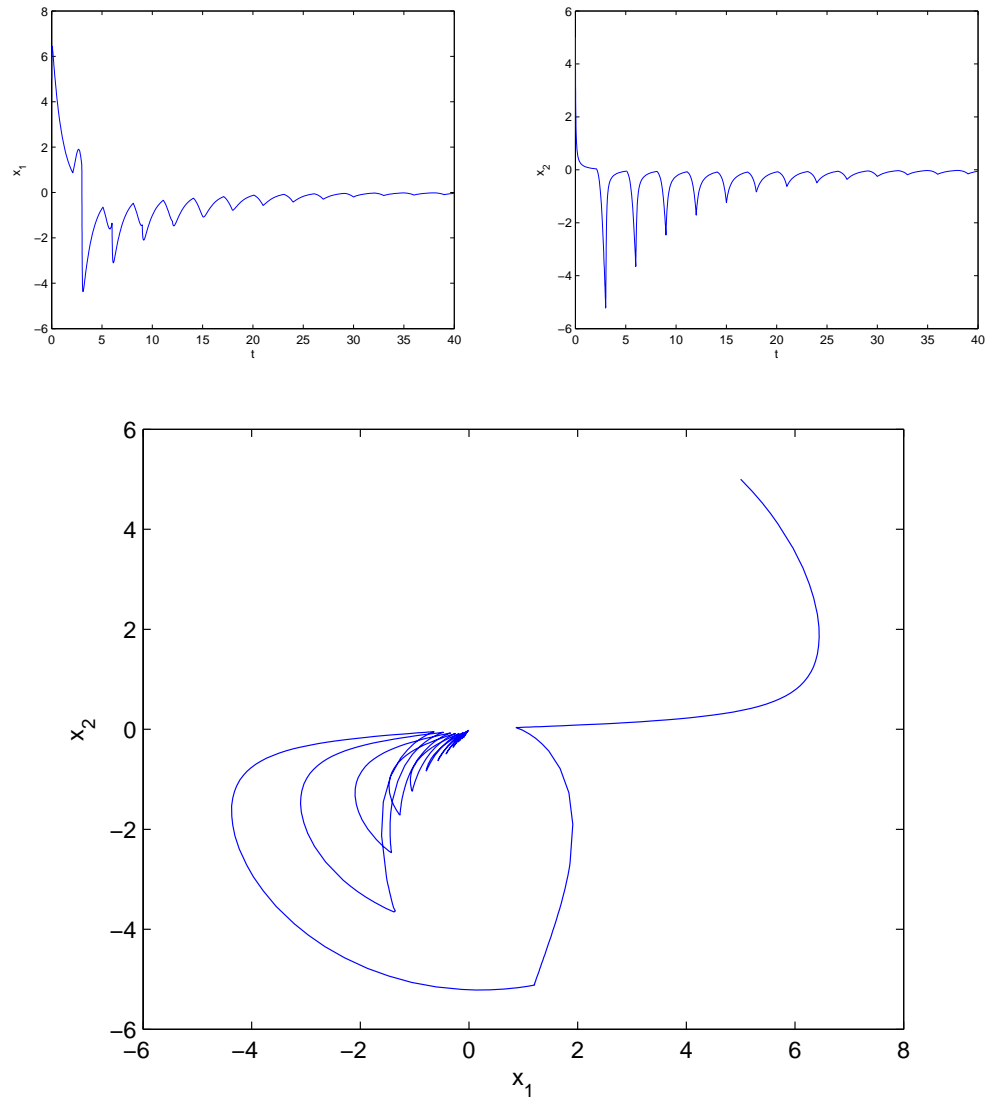

Figure 2.5 Simulation for Example 2.4.2 with switching signal (2.4.45) and initial condition $x(0)=[5 \ 5]$.

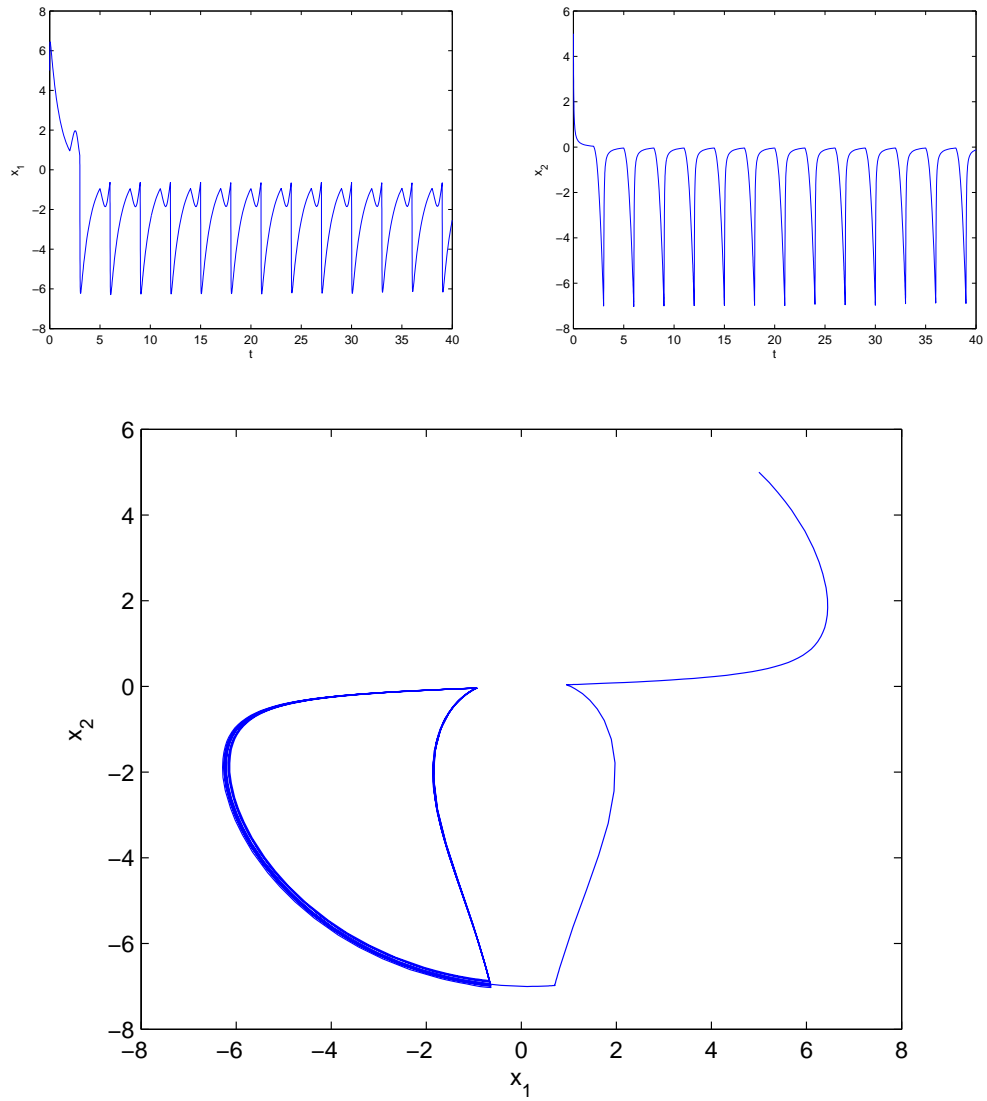

Figure 2.6 Simulation for Example 2.4.2 with switching signal (2.4.46) and initial condition $x(0)=[5 \ 5]$.

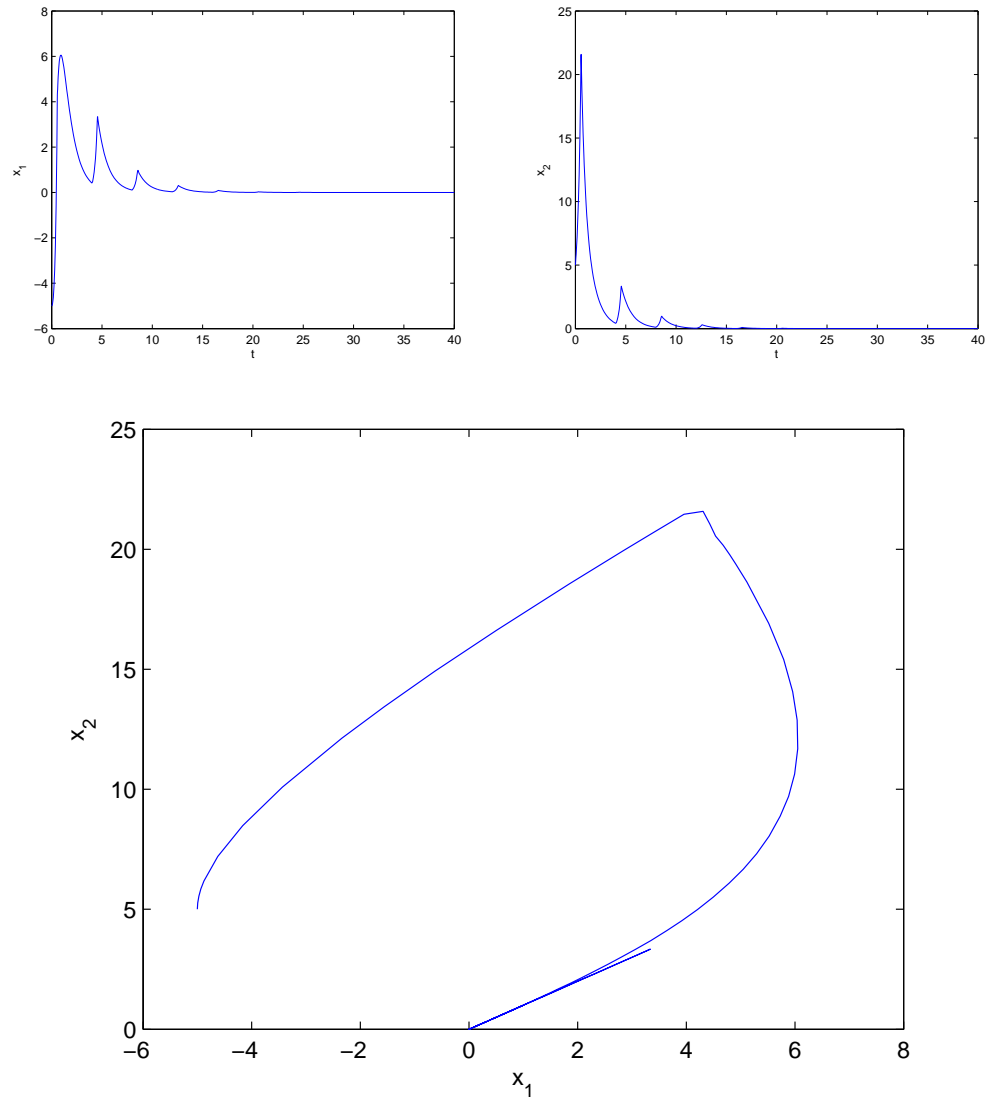

Figure 2.7 Simulation for Example 2.4.3 with switching signal (2.4.47) and initial condition $x(0)=[-5 \ 5]$.

Simulation results given in Figure 2.6 indicate that the switched system is no longer asymptotically stable under the switching law σ_2 , which is nevertheless in $\mathcal{S}(\frac{1}{2}, T)$ for all T . \square

Example 2.4.3 [199] Consider the switched system (2.4.40) with $\mathcal{I} = \{1, 2\}$ and

$$A_1 = \begin{bmatrix} 2 & 2 \\ 1 & 3 \end{bmatrix}, \quad A_2 = \begin{bmatrix} -2 & 1 \\ 1 & -2 \end{bmatrix},$$

where A_1 is unstable while A_2 is stable.

An LMI Approach. According to Remark 2.4.8, we may solve the LMIs (2.4.41), (2.4.42), and (2.4.43) directly when ρ, μ , and λ are preset. Now with $\tau = 2$ and $r = \frac{1}{8}$, we can set

$$\rho = 2, \quad \mu = 8, \quad \lambda = 2,$$

such that (2.4.44) is satisfied as

$$\frac{\ln \rho}{\tau} + \frac{\mu r - \lambda}{1 + r} = -0.5423 < 0.$$

Solving (2.4.41), (2.4.42), and (2.4.43) gives

$$Q_1 = \begin{bmatrix} 272.0306 & 85.0468 \\ 85.0468 & 178.5387 \end{bmatrix},$$

and

$$Q_2 = \begin{bmatrix} 225.9363 & 53.2988 \\ 53.2988 & 225.9363 \end{bmatrix}.$$

Therefore, by Theorem 2.4.4, the switching system is uniformly exponentially stable over $\mathcal{S} \subset \mathcal{S}_a(2, N_0) \cap \mathcal{S}(\frac{1}{8}, T)$ for any $N_0 > 0$ and $T_0 \geq 0$. Moreover, according to Remark 2.4.7, the exponential decay rate of the system is guaranteed to be no less than $\frac{0.5423}{2} = 0.2712$. In [199], it has been shown that, when choosing $\tau = 2.5, r = \frac{1}{9}$, the decay rate is 0.25. Therefore even with a smaller average dwell-time and a longer total activation time of the unstable subsystem, the decay rate of the switched system guaranteed by our results is still greater than that in [199]. This shows that, even as a very special case, there is a slight improvement of our results over the ones in [199], at least in this particular numerical example.

Simulation. In order that system (2.4.40) is stable, we can activate subsystem 1 and

subsystem 2 for time periods of 0.45 and 3.85, respectively, e.g., we can choose the following switching signal

$$\sigma_3(t) = \begin{cases} 1, & t \in [4k, 4k + 0.57), k \in \mathbb{Z}^+, \\ 2, & t \in [4k + 0.57, 4k + 4), k \in \mathbb{Z}^+, \end{cases} \quad (2.4.47)$$

such that $\sigma_3 \in \mathcal{S}_a(2, N_0) \cap \mathcal{S}(\frac{1}{8}, T)$ when N_0 and T are sufficiently large. Figure 2.7 shows the simulation results for this particular switching signal, which verify the predicted exponential stability. \square

2.5 Switching Stabilization of Nonlinear Systems

In [106] and [161], some basic problems related to the stability issues of switched systems are surveyed, among which we note, in particular, the problem of constructing stabilizing switching rules for a family of unstable systems. In [182] (see also [183]), the following problem is addressed:

Given two linear system $x' = A_1x$ and $x' = A_2x$, where A_1 and A_2 are not Hurwitz in that they both have some eigenvalues in the right half plane, determine if there exists a switching rule such that the resulting switched system is stable.

It is established in [182] that, if there exists a Hurwitz convex linear combination of A_1 and A_2 , i.e., there exists some $\alpha \in [0, 1)$ such that $\alpha A_1 + (1 - \alpha)A_2$ is Hurwitz, then a stabilizing switching rule does exist. This result can be easily generalized to the case of a switched system with finitely many subsystems. Namely, consider a family of linear systems with coefficient matrices A_1, A_2, \dots, A_N and assume there exists a Hurwitz convex linear combination of these matrices, i.e., there exist real numbers $\alpha_i \in (0, 1)$ with $\sum_{i=1}^N \alpha_i = 1$ such that $\sum_{i=1}^N \alpha_i A_i$ is Hurwitz. Then a stabilizing switching rule can also be constructed. The idea of proof involves constructing a common quadratic Lyapunov function and the stability obtained is actually quadratic stability. In [168], time-dependent fast periodic switching rules are constructed for families of linear systems, based on a more direct approach analyzing the state transition matrix.

Later, the work of [182] is extended in [181], by using piecewise quadratic Lyapunov functions as opposed to quadratic Lyapunov functions. It is also extended in [6] to the cases when there exists a convex combination of A_1 and A_2 with the property that all of its eigenvalues have nonpositive real parts and any eigenvalues on the imaginary axis are simple.

All the results above, however, rely on the existence of a quadratic Lyapunov function and only apply to switched linear systems. It is natural to ask if similar results can be obtained for switched nonlinear systems. We aim to address this problem in this section. The main results will deal with general switched nonlinear systems. Under a suitably modified assumption on the property of a convex linear combination of the nonlinear vector fields, it is shown that a state-dependent switching rule can be constructed so that the resulting switched system is asymptotically stable. It is formally proved that the stabilizing switching signal, which is generated to stabilize the family of individually unstable subsystems, does not exhibit chattering. Moreover, we can further prove that Zeno behavior can be prevented by introducing a generalized rule to generate stabilizing switching signals. It should be mentioned that, in the recent paper [5], the authors also investigate the stabilization of nonlinear systems using discontinuous feedback, corresponding to switching stabilization to be considered in the section. Their results can be applied to general families of nonlinear systems. A key difference between the results in [5] and the results to be presented in this section is that their results deal with solutions in the Krasowski sense and a switching signal is only required to be measurable, whereas we focus on classical solutions and require that the stabilizing switching signals are piecewise constant and well-defined in the classical sense.

Since the concept of stability in terms of two measures provides a unified notion for Lyapunov stability, partial stability, orbital stability, and stability of an invariant set of nonlinear systems ([100], [118]), it would be desirable that we can formulate the stability results in terms of two measures. It is worth noting that this notion has been adopted in the framework of switched systems in [34].

The rest of this chapter is organized as follows. In Section 2.5.1, necessary notations and definitions are given, including the (h_0, h) -stability notion for switched systems. The main results are presented in Sections 2.5.2 and 2.5.3. Both the minimal rule and generalized rule are introduced, and two types of stabilizing switchings are proposed, both based on a partition of the time-state space. A sequence of propositions are presented to establish some important properties of both the minimal rule and the generalized rule. Particularly, it is shown that the switching signals constructed do not exhibit chattering, and, under the general rule, Zeno behavior is also excluded. The main theorems then show that the resulting switched system is indeed (h_0, h) -globally uniformly asymptotically stable and (h_0, h) -globally uniformly exponentially stable, respectively. Applications of the main

theorems are shown by several examples in Section 2.5.4, where the simulation results are also presented to both illustrate and verify the stability analysis. Particularly, following Example 2.5.1, an in-depth discussion on the comparison between a minimal switching solution and a generalized rule switching is presented. Finally, this chapter is summarized by Section 2.6.

2.5.1 Notions of (h_0, h) -Stability

We introduce the following special class of functions

$$\Gamma = \left\{ h \in C(\mathcal{R}^+ \times \mathcal{R}^n; \mathcal{R}^+) : \inf_{(t,x)} h(t,x) = 0 \right\}.$$

Let $h_0, h \in \Gamma$ and $x(t) = x(t; t_0, x_0)$ denote a solution of system (2.1.1) under a particularly designed switching signal σ and with initial condition $x(t_0) = x_0$. We define uniform stability, global uniform asymptotic stability and global exponential stability in terms of two measures for the switched system (2.1.1) under this particular switching signal. Other stability notions in terms of two measures can be defined similarly based on those given in [100].

Definition 2.5.1 The switched system (2.1.1) is said to be

- (\mathcal{S}_1) (h_0, h) -**uniformly stable** if, for each $\varepsilon > 0$, there exists a $\delta(\varepsilon) > 0$ such that $h_0(t_0, x_0) < \delta$ implies that $h(t, x(t)) < \varepsilon$ for all $t \geq t_0$;
- (\mathcal{S}_2) (h_0, h) -**globally uniformly asymptotically stable** if (\mathcal{S}_1) is satisfied and, for each $\rho > 0$ and each $\varepsilon > 0$, there exists $T = T(\rho, \varepsilon) > 0$ such that $h_0(t_0, x_0) < \rho$ implies that $h(t, x(t)) < \varepsilon$ for all $t \geq t_0 + T$;
- (\mathcal{S}_3) (h_0, h) -**globally uniformly exponentially stable** if there exist positive constants K and λ , independent of t_0 and x_0 , such that

$$h(t, x(t)) \leq K h_0(t_0, x_0) e^{-\lambda(t-t_0)},$$

for all $t \geq t_0$. □

2.5.2 (h_0, h) -Global Uniform Asymptotic Stabilization

The following assumption plays an important role in the construction of a stabilizing switching rule.

Assumption 2.5.1 Suppose that the index set \mathcal{I} is finite and given by $\{1, 2, \dots, N\}$. There exists a convex linear combination of $\{f_i : i \in \mathcal{I}\}$, i.e.,

$$f_\alpha = \sum_{i=1}^N \alpha_i f_i,$$

with $\alpha_i \in [0, 1)$ and $\sum_{i=1}^N \alpha_i = 1$, a function $V \in C^1[\mathcal{R}^+ \times \mathcal{R}^n; \mathcal{R}^+]$, and functions $h_0, h \in \Gamma, a, b \in \mathcal{K}_\infty, c \in \mathcal{K}$ such that

$$a(h(t, x)) \leq V(t, x) \leq b(h_0(t, x)), \quad \forall (t, x) \in \mathcal{R}^+ \times \mathcal{R}^n, \quad (2.5.1a)$$

$$\frac{\partial V}{\partial t}(t, x) + \frac{\partial V}{\partial x}(t, x) \cdot f_\alpha(t, x) \leq -c(h_0(t, x)), \quad \forall (t, x) \in \mathcal{R}^+ \times \mathcal{R}^n. \quad (2.5.1b)$$

In addition, V satisfies the following:

- (i) a solution that satisfies any of the subsystems of (2.1.1) with $(t_0, x(t_0)) \in \Gamma_0 = \{(t, x) \in \mathcal{R}^+ \times \mathcal{R}^n : V(t, x) = 0\}$ will stay in Γ_0 for all $t \geq t_0$; and
- (ii) the set

$$U(\varepsilon, \rho, [t_0, T]) = \{(t, x) \in [t_0, T] \times \mathcal{R}^n : \varepsilon \leq V(t, x) \leq \rho\},$$

where $0 < \varepsilon \leq \rho < \infty$ and $0 \leq t_0 < T < \infty$, is bounded. \square

Remark 2.5.1 Inequality (2.5.1a) states that the function V is h -positive definite, h -radially unbounded, and h_0 -decreasing. Inequality (2.5.1b), inspired by the well-known results in [182], [181], [183] for linear systems, essentially proposes an assumption on the nonlinear vector fields $\{f_i : i \in I\}$ in terms of a smooth Lyapunov function for a linear convex combination of the nonlinear vector fields. Part (i) of the additional conditions says that the set Γ_0 is positively invariant with respect to each of the subsystems. In particular, if $h_0 = h = |x|$, this corresponds to that the trivial solution $x = 0$ is the unique solution for each of the subsystems in (2.1.1) on $[t_0, \infty)$ with $x(t_0) = 0$. In part (ii), boundedness of the set $U(\varepsilon, \rho, [t_0, T])$ is very easy to check and usually follows from radially unboundedness of the function V . Moreover, continuity of V and boundedness of the set $U(\varepsilon, \rho, [t_0, T])$ implies that it is compact, a key property to be used later. \square

Based on this assumption, we proceed to construct a switching signal. Define

$$\Omega_i = \left\{ (t, x) \in \mathcal{R}^+ \times \mathcal{R}^n : \dot{V}_i(t, x) \leq -c(h_0(t, x)) \right\},$$

where the function $\dot{V}_i(t, x)$ is defined by (2.3.1) (see Remark 2.3.1). A switching signal will be constructed based on this partition of the time-state space. The idea of hysteresis-based switching [107] is important here to prevent chattering and maintain the property that the switching signal function $\sigma(t)$ has only a finite number of discontinuities on every bounded time interval. To define the hysteresis switching, the regions Ω_i are enlarged so that they can have some overlaps near the boundaries. Define Ω'_i as

$$\Omega'_i = \left\{ (t, x) \in \mathcal{R}^+ \times \mathcal{R}^n : \dot{V}_i(t, x) \leq -\frac{1}{\zeta} c(h_0(t, x)) \right\},$$

where $\zeta > 1$ can be arbitrarily chosen. A switching signal σ can be constructed by the following *minimal rule*.

(R₁) Starting from some $t = t_0$, if $V(t_0, x_0) = 0$, let $\sigma(t) \equiv i_0$ for all $t \geq t_0$, where $i_0 \in I$ can be arbitrarily chosen. If $V(t_0, x_0) \neq 0$, let

$$\sigma(t_0) = \arg \min_i \dot{V}_i(t_0, x(t_0)),$$

where \arg denotes the value of the argument i such that the minimal is attained;

(R₂) Maintain $\sigma = i$ as long as $(t, x(t)) \in \Omega'_i$ and $\sigma(t^-) = i$;

(R₃) Once $(t_1, x(t_1))$ hits the boundary $\partial\Omega'_i$ of Ω'_i for some t_1 , let $t_0 = t_1$ and start over according to (R₁).

To guarantee that the switching is well-defined, we first show that $\{\Omega_i\}$ forms a covering of the time-state space.

Proposition 2.5.1 *If Assumption 2.5.1 holds, then $\cup_{i=1}^N \Omega_i = \mathcal{R}^+ \times \mathcal{R}^n$.*

Proof. Suppose $\cup_{i=1}^N \Omega_i \neq \mathcal{R}^+ \times \mathcal{R}^n$, i.e., there exists a pair $(t, x) \in \mathcal{R}^+ \times \mathcal{R}^n$ such that $(t, x) \notin \cup_{i=1}^N \Omega_i$. By the definition of Ω_i , this implies

$$\dot{V}_i(t, x) = \frac{\partial V}{\partial t}(t, x) + \frac{\partial V}{\partial x}(t, x) \cdot f_i(t, x) > -c(h_0(t, x)).$$

It follows that

$$\begin{aligned}
\frac{\partial V}{\partial t}(t, x) + \frac{\partial V}{\partial x}(t, x) \cdot f_\alpha(t, x) &= \frac{\partial V}{\partial t}(t, x) \sum_{i=1}^N \alpha_i + \frac{\partial V}{\partial x}(t, x) \cdot \sum_{i=1}^N \alpha_i f_i(t, x) \\
&= \sum_{i=1}^N \alpha_i \left[\frac{\partial V}{\partial t}(t, x) + \frac{\partial V}{\partial x}(t, x) \cdot f_i(t, x) \right] \\
&> \sum_{i=1}^N \alpha_i [-c(h_0(t, x))] \\
&= -c(h_0(t, x)), \tag{2.5.2}
\end{aligned}$$

where the coefficients α_i are from Assumption 2.5.1. Since (2.5.2) contradicts inequality (2.5.1b) in Assumption 2.5.1, one must have $\cup_{i=1}^N \Omega_i = \mathcal{R}^+ \times \mathcal{R}^n$ if Assumption 2.5.1 holds. This completes the proof. \square

The following proposition, as an immediate consequence of Assumption 2.5.1, plays an important role in the sequel. Denote

$$\Gamma_i = \left\{ (t, x) \in \mathcal{R}^+ \times \mathcal{R}^n : \arg \min_i \dot{V}_i(t, x) = i \right\}, \quad i \in I.$$

Clearly, each Γ_i is a closed set and $\cup_{i \in I} \Gamma_i = \mathcal{R}^+ \times \mathcal{R}^n$.

Proposition 2.5.2 *Under Assumptions 2.5.1, the set $\partial\Omega'_i \cap \Gamma_j \cap \partial\Omega'_j \cap U(\varepsilon, \rho, [t_0, T])$ is empty for all $i, j \in I$, $0 < \varepsilon \leq \rho < \infty$, and $0 \leq t_0 < T < \infty$.*

Proof. It suffices to show that $\partial\Omega'_i \cap U(\varepsilon, \rho, [t_0, T])$ and $\Gamma_i \cap U(\varepsilon, \rho, [t_0, T])$ are disjoint for all $i \in I$. Suppose this is not true and let (t^*, x^*) be an element in both $\partial\Omega'_i \cap U(\varepsilon, \rho, [t_0, T])$ and $\Gamma_i \cap U(\varepsilon, \rho, [t_0, T])$. It is clear that $V(t^*, x^*) > 0$ and hence $c(h_0(t^*, x^*)) > 0$. Note that $(t^*, x^*) \in \partial\Omega'_i$ implies

$$\dot{V}_i(t^*, x^*) = -\frac{1}{\zeta} c(h_0(t^*, x^*)),$$

and $(t^*, x^*) \in \Gamma_i$ implies

$$\dot{V}_i(t^*, x^*) \geq \dot{V}_j(t^*, x^*), \quad \forall j \in I.$$

It follows that

$$\dot{V}_i(t^*, x^*) \geq -\frac{1}{\zeta} c(h_0(t^*, x^*)), \quad \forall j \in I,$$

which in turn implies that

$$\frac{\partial V}{\partial t}(t^*, x^*) + \frac{\partial V}{\partial x}(t^*, x^*) \cdot f_\alpha(t^*, x^*) \geq -\frac{1}{\zeta} c(h_0(t^*, x^*)) > -c(h_0(t^*, x^*)),$$

where $c(h_0(t^*, x^*)) > 0$, which contradicts Assumption 2.5.1. \square

The following proposition formally confirms that no chattering occurs in a switching signal σ constructed according to the minimal rule (\mathbf{R}_1) – (\mathbf{R}_3) .

Proposition 2.5.3 *Under Assumption 2.5.1, a switching signal σ constructed according to the minimal rule (\mathbf{R}_1) – (\mathbf{R}_3) obeys the following:*

- (i) *Let t^* be a switching time of σ . There exists a positive constant ε , which may depend on $(t^*, x(t^*))$, such that no switching occurs within $[t^*, t^* + \varepsilon)$;*
- (ii) *The switching signal σ has a positive dwell-time as long as*

$$(t, x(t)) \in U(\varepsilon, \rho, [t_0, T]),$$

where $U(\varepsilon, \rho, [t_0, T])$ is from Assumption 2.5.1, i.e., there exists a constant $\delta > 0$, which may depend on the set $U(\varepsilon, \rho, [t_0, T])$, such that any two switching times of σ on $[t_0, T]$ is separated by at least δ unit of time;

- (iii) *Given $t' \geq t \geq t_0$, we have $V(t', x(t')) \leq V(t, x(t)) \leq V(t_0, x(t_0))$.*

Proof. (i) Note that t^* being a switching time of σ implies $(t^*, x(t^*)) \in \partial\Omega'_i$ for some $i \in I$. If $V(t^*, x(t^*)) = 0$, the conclusion is true, since it is defined by the minimal rule that $\sigma(t) \equiv i_0$ for some fixed $i_0 \in I$ and all $t \geq t^*$. Now suppose $V(t^*, x(t^*)) \neq 0$ and $(t^*, x(t^*)) \in \partial\Omega'_i$. It is clear that we can choose a set $U(\varepsilon, \rho, [t_0, T])$ such that $(t^*, x(t^*)) \in U(\varepsilon, \rho, [t_0, T])$. Moreover, the minimal rule chooses the next mode to be j by letting $\sigma(t^*) = j$, where

$$j = \arg \min_i \dot{V}_i(t^*, x(t^*)),$$

i.e., $(t^*, x(t^*)) \in \Gamma_j$. Proposition 2.5.2 says that $(t^*, x(t^*)) \notin \partial\Omega'_j$. Therefore, it takes a positive amount of time for $(t, x(t))$ to reach Ω'_j and for the next switching to take place.

(ii) Let t^* be a switching time of σ , which implies that $(t^*, x(t^*)) \in \partial\Omega'_i$ for some $i \in I$. As shown in part (i), the next mode $j, j \neq i$, is determined by the minimal rule such that $(t^*, x(t^*)) \in \Gamma_j$, and the next switching time is when $(t, x(t)) \in \partial\Omega'_j$ occurs. According to

Proposition 2.5.2, $\partial\Omega'_i \cap \Gamma_j$ and $\partial\Omega'_j$ are disjoint within $U(\varepsilon, \rho, [t_0, T])$, and $U(\varepsilon, \rho, [t_0, T])$ is compact by Assumption 2.5.1. Therefore, as long as $(t, x(t))$ remains in $U(\varepsilon, \rho, [t_0, T])$, it takes a minimal time for $(t, x(t))$ to travel from $\partial\Omega'_i \cap \Gamma_j$ to $\partial\Omega'_j$, considering that $\partial\Omega'_i \cap \Gamma_j$ and $\partial\Omega'_j$ are both closed sets and disjoint in $U(\varepsilon, \rho, [t_0, T])$, and that each element of the vector fields $\{f_i : i \in I\}$ is continuous and hence bounded on the compact set $U(\varepsilon, \rho, [t_0, T])$. Note that each $\partial\Omega'_i$ can be finitely partitioned as $\partial\Omega'_i = \cup_{j \in I} (\partial\Omega'_i \cap \Gamma_j)$ and the index set I is finite. It follows that a positive dwell-time exists if $(t, x(t))$ remains in $U(\varepsilon, \rho, [t_0, T])$.

(iii) Differentiating $V(t, x(t))$ with respect to t gives

$$\frac{dV}{dt}(t, x(t)) = \frac{\partial V}{\partial t}(t, x(t)) + \frac{\partial V}{\partial x}(t, x(t)) \cdot f_{\sigma(t)}(t, x(t)).$$

According to the construction of σ , one has

$$\frac{dV}{dt}(t, x(t)) \leq -\frac{1}{\zeta} c(h_0(t, x(t))) \leq 0, \quad (2.5.3)$$

which implies that $V(t, x(t))$ is nonincreasing for $t \geq t_0$. The proof is complete. \square

Although Proposition 2.5.3 shows that a switching signal generated by the minimal rule (\mathbf{R}_1) – (\mathbf{R}_3) has no chattering, the minimal rule alone cannot exclude the possibility of **Zeno behavior**, i.e., the switched system undergoes an infinite number of switchings within a finite interval of time. To guarantee that no Zeno behavior occurs, based on the minimal rule (\mathbf{R}_1) – (\mathbf{R}_3) , we further propose a **generalized rule**. Define

$$\mathcal{D}_k = \left\{ (t, x) \in \mathcal{R}^+ \times \mathcal{R}^n : 2^k < V(t, x) \leq 2^{k+1} \right\}, \quad k \in \mathcal{Z},$$

where V is from Assumption 2.5.1 and \mathcal{Z} denotes the set of all integers. A switching signal can be constructed by the following generalized rule. Let $\tau > 0$ be an arbitrary positive real number.

- (GR₁) Starting from some $t = t_0$, if $V(t_0, x_0) = 0$, let $\sigma(t) \equiv i_0$ for all $t \geq t_0$, where $i_0 \in I$ can be arbitrarily chosen. If $V(t_0, x_0) \neq 0$ and $(t_0, x_0) \in \mathcal{D}_{k_0}$ for some $k_0 \in \mathcal{Z}$, maintain the minimal rule (\mathbf{R}_1) – (\mathbf{R}_3) until $(t_1, x(t_1)) \in \overline{\mathcal{D}_{k_0-2}}$ for some t_1 and proceed to (GR₂);
- (GR₂) If $t_1 - t_0 \geq \tau$, let $t_1 = t_0$ and start over according to (GR₁). If $t_1 - t_0 < \tau$, maintain σ unchanged until $t_2 - t_0 \geq \tau$ or $(t_2, x(t_2)) \in \overline{\mathcal{D}_{k_0}}$ for some t_2 , whichever occurs first. If $t_2 - t_0 \geq \tau$ occurs first, let $t_0 = t_2$ and start over according to (GR₁). If $(t_2, x(t_2)) \in \overline{\mathcal{D}_{k_0}}$ occurs first, proceed to (GR₃);

(GR₃) Maintain the minimal rule (R₁)–(R₃) until $(t_3, x(t_3)) \in \overline{\mathcal{D}_{k_0-2}}$ for some t_3 . Let $t_1 = t_3$ and proceed according to (GR₂).

We call it a *cycle* of the generalized rule (GR₁)–(GR₃) and, unambiguously, a cycle of a switching signal generated by (GR₁)–(GR₃), once we start over according to (GR₁). Each cycle consists of two portions of time: a portion spent while the minimal rule (R₁)–(R₃) is engaged, which we call the *minimal rule time*, and the other spent without the minimal rule engaged, which we call the *wandering time*. The positive constant τ is called the (*minimal*) *cycle time*. We observe the following crucial properties of the generalized rule.

Proposition 2.5.4 *Under Assumption 2.5.1, a switching signal constructed according to the generalized rule (GR₁)–(GR₃) obeys the following:*

- (i) *The switching signal is well-defined;*
- (ii) *Let t_0 be the starting time of any cycle. We have $V(t, x(t)) \leq V(t_0, x(t_0))$ for all $t \geq t_0$;*
- (iii) *Let $t_0 < t'_0 < t''_0$ be the starting times of any three consecutive cycles. We have*

$$V(t''_0, x(t''_0)) \leq \frac{1}{2} V(t_0, x(t_0));$$

- (iv) *Each cycle lasts for at least τ unit of time. If a cycle contains an interval of the form $[t' - \tau, t' + T]$ with some $T > 0$ (i.e., the duration of this cycle is strictly greater than τ), then the minimal is maintained on the interval $[t', t' + T]$. Moreover, picking any $t^* \in [t', t' + T]$, we have $V(t, x(t)) \leq V(t^*, x(t^*))$ for all $t \geq t^*$.*

Proof. (i) Note that each cycle lasts for at least τ unit of time. Fix any finite interval of the form $[T_1, T_2] \subset \mathcal{R}^+$. We have to show that at most finitely many switchings can occur during this interval. Since there are only a finite number of cycles contained in $[T_1, T_2]$, it suffices to show that each cycle in $[T_1, T_2]$ contains at most finitely many switching times. Let $[\tau_1, \tau_2]$ denote such a cycle, where τ_2 is either the end of this cycle or T_2 (the end of the finite interval considered). Without loss of generality, suppose $V(\tau_1, x(\tau_1)) \neq 0$ and $(\tau_1, x(\tau_1)) \in \mathcal{D}_{k_0}$ for some $k_0 \in \mathcal{Z}$ (the trivial case $V(\tau_1, x(\tau_1)) = 0$ would imply that $[\tau_1, \tau_2]$ is continuously spent as minimal rule time and there is no switching). Note that, during $[\tau_1, \tau_2]$, the minimal rule is engaged only when $(t, x(t)) \in \overline{\mathcal{D}_{k_0-1} \cup \mathcal{D}_{k_0}}$, where $k_0 \in \mathcal{Z}$ is fixed for each cycle, which implies that the minimal rule time of this cycle is spent (not

necessarily continuously) in $U(2^{k_0-1}, 2^{k_0+1}, [\tau_1, \tau_2])$. According to Proposition 2.5.3 (ii), only a finite number of switchings can occur during the minimal rule time in $[\tau_1, \tau_2]$. In addition, note that there is no switching during wandering time. The only possibility to have infinitely many switchings during $[\tau_1, \tau_2]$ is switching back and forth between the wandering time and minimal rule time infinitely many times. However, note that the wandering time starts from $(t, x(t)) \in \overline{\mathcal{D}_{k_0-2}}$ and ends when either the minimal cycle time τ is achieved or $(t, x(t)) \in \overline{\mathcal{D}_{k_0}}$. In the former case, the cycle also ends. In the latter case, since k_0 is fixed, it can be shown that it takes a minimal amount of time for $(t, x(t))$ to travel from $\overline{\mathcal{D}_{k_0-2}}$ to $\overline{\mathcal{D}_{k_0}}$. Therefore, the end point τ_2 is reached through a finite number of switching out from the wandering time. It has been shown that it is impossible to have infinitely many switchings during $[\tau_1, \tau_2]$, and so is it during $[T_1, T_2]$, an arbitrarily fixed finite subinterval of \mathcal{R}^+ . The proof of part (i) is complete.

(ii)–(iv) The proof follows from the construction of a switching signal according to the generalized rule (GR₁)–(GR₃) and the monotonicity property of the minimal rule shown in Proposition 2.5.3 (iii). The proof is complete. \square

The above proposition first confirms that a switching signal generated by the generalized rule (GR₁)–(GR₃) is actually well-defined, and then establishes some important monotonicity properties of generalized rule for later use.

Remark 2.5.2 The intuitive idea behind the generalized rule (GR₁)–(GR₃) is to prevent $V(t, x(t))$ from converging to 0 through an infinite number of switching within a finite interval of time. The minimal rule is maintained if $V(t, x(t))$ is converging to 0 “not too fast”, which in this case means not faster than a certain exponential decay. If $V(t, x(t))$ is decreasing too fast, the minimal rule time is succeeded by a portion of “wandering time” in which the switching signal is maintained constant without engaging the minimal rule. During the wandering time, it is expected that $V(t, x(t))$ would rise, since each of the subsystem is assumed to be unstable. Therefore, the simple monotonicity property of the minimal rule, as shown in Proposition 2.5.3, can be violated. Nevertheless, we can establish certain monotonicity properties of the generalized rule, as shown in the above proposition. \square

Remark 2.5.3 The problem whether a state-dependent switching rule based on a partition of the state space is actually well-defined and can be converted to a piecewise time-dependent signal is difficult. Very few results are available on this topic. In [33], the author

investigates systems with finite valued discontinuous feedbacks and gives some necessary conditions to cause Zeno phenomenon in the finite valued feedback laws. Our generalized rule (\mathbf{GR}_1) – (\mathbf{GR}_3) not only considers the partition of the time-state space, but also takes advantage of the properties of the Lyapunov function V . As shown in Propositions 2.5.3 and 2.5.4, both chattering and Zeno phenomenon are prevented under the generalized rule. Therefore, the switching signals constructed and the resulting switched systems are well-defined in the classical sense. It should also be pointed out that the generalized rule (\mathbf{GR}_1) – (\mathbf{GR}_3) introduces a dependence on the time (due to the minimal cycle time), while the minimal rule (\mathbf{R}_1) – (\mathbf{R}_3) is purely state-dependent (although with memory due to the hysteresis switching). \square

Before stating the main theorem, we make the following remark regarding the existence of solution by the boundedness of $h(t, x(t))$ in future time.

Remark 2.5.4 In the classical Lyapunov stability theorems, the existence of every solution in the future time is guaranteed by the fact that the theorem conditions imply solutions are bounded in the future and hence exist globally. A similar thing can be said for (h_0, h) -stability analysis, i.e., the boundedness of $h(t, x(t))$ implies future existence of the solution $x(t)$. For example, $h(t, x) = |\dot{q}|$, where $x^T = (q, \dot{q})$; and $h(t, x) = d(x(t), A)$, where A is a compact invariant set and $d(\cdot)$ is the distance function. Thus we assume that, if $h(t, x(t))$ is bounded for all $t \geq t_0$, then the solution $x(t)$ exists for all $t \geq t_0$. \square

Theorem 2.5.1 *If Assumption 2.5.1 holds, then the switched system (2.1.1) is (h_0, h) -globally uniformly asymptotically stable*

- (i) *under the switching signal σ constructed according to (\mathbf{R}_1) – (\mathbf{R}_3) , with the possibility that σ has a finite accumulation point t^* for its switching times, and $x(t) = 0$ for all $t \geq t^*$;*
- (ii) *under the switching signal σ constructed according to (\mathbf{GR}_1) – (\mathbf{GR}_3) , and σ is well-defined.*

Proof. (i) Since V in Assumption 2.5.1 is h -positive definite, h -radially unbounded, and h_0 -decreasing, there exist functions $u, v \in \mathcal{K}_\infty$ such that

$$u(h(t, x)) \leq V(t, x) \leq v(h_0(t, x)), \quad \forall (t, x) \in \mathcal{R}^+ \times \mathcal{R}^n. \quad (2.5.4)$$

Given $\varepsilon > 0$ and $t_0 \geq 0$, choose $\delta = \delta(\varepsilon)$ independent of t_0 and sufficiently small such that $v(\delta) < u(\varepsilon)$. We proceed to show that every solution $x(t; t_0, x_0)$ of (2.1.1) with $h_0(t_0, x_0) < \delta$

verifies

$$h(t, x(t)) < \varepsilon, \quad t \geq t_0. \quad (2.5.5)$$

According to Proposition 2.5.3 (iii) and (2.5.4), one has

$$u(h(t, x(t))) \leq V(t, x(t)) \leq V(t_0, x_0) \leq v(h_0(t_0, x_0)) < v(\delta) < u(\varepsilon), \quad (2.5.6)$$

for all $t \geq t_0$. Since $u \in \mathcal{K}_\infty$, (2.5.5) is verified and (h_0, h) -uniform stability follows. We proceed to show (h_0, h) -global attraction. Still let $\varepsilon > 0$ and t_0 be arbitrarily fixed. Choose $\delta = \delta(\varepsilon)$ independent of $t_0 \geq 0$ and sufficiently small such that $v(\delta) < u(\varepsilon)$. For an arbitrarily fixed $\rho > 0$, let $T(\rho, \varepsilon) = \zeta v(\rho)/c(\delta) + 1$ and $x(t; t_0, x_0)$ be an arbitrary solution with $h_0(t_0, x_0) < \rho$. Since $u \in \mathcal{K}_\infty$, one can choose η large such that $u(\eta) > v(\rho)$. Then, by (2.5.4), one has

$$u(h(t, x(t))) \leq V(t, x(t)) \leq V(t_0, x_0) \leq v(h_0(t_0, x_0)) < v(\rho) < u(\eta),$$

for all $t \geq t_0$, which implies $h(t, x(t))$ is bounded in the future and hence, by the assumption in Remark 2.5.4, $x(t)$ exists for all $t \geq t_0$.

Claim. There exists $t^* \in [t_0, t_0 + T]$ such that $h_0(t^*, x(t^*)) < \delta$.

Proof of the Claim. Suppose the claim is not true. Then $h_0(t, x(t)) \geq \delta$ for all $t \in [t_0, t_0 + T]$. It follows, from (2.5.4) and (2.5.3), that

$$0 \leq V(T, x(T)) \leq V(t_0, x_0) - \frac{1}{\zeta} \int_{t_0}^{t_0+T} c(h_0(s, x(s))) ds \leq v(\rho) - \frac{c(\delta)T}{\zeta} < 0,$$

which is a contradiction and the claim is proved.

Since $\delta > 0$ is the same (h_0, h) -stability constant as above, it follows from (2.5.6) that $h(t, x(t)) < \varepsilon$ for all $t \geq t^*$ and hence for $t \geq t_0 + T$. This completes the proof for part (i).

(ii) The proof of part (ii) is based on that of part (i). The proof for (h_0, h) -uniform stability remains the same, since the estimate (2.5.6) remains valid in view of Proposition 2.5.4 (iii). To show (h_0, h) -global attraction, let $\varepsilon > 0$, t_0, δ, ρ, T , and $x(t; t_0, x_0)$ be the same as in the proof of part (i).

We aim to show that there exists some $T' > 0$, independent of t_0 , such that $h(t, x(t)) < \varepsilon$ for all $t \geq t_0 + T'$. It is clear that there exists a positive integer k_0 such that $2^{-k_0} v(\rho) < u(\varepsilon)$. We choose $T' = (2k_0 + 1)(T + \tau)$ and show that $h(t, x(t)) < \varepsilon$ for all $t \geq t_0 + T'$. Suppose there are more than $2k_0 + 1$ cycles of the generalized rule between t_0 and $t_0 + T'$. Then (iii)

of Proposition 2.5.4 implies that

$$V(t, x(t)) \leq V(t^*, x(t^*)) \leq 2^{-k_0} V(t_0, x_0) \leq 2^{-k_0} v(\rho) < u(\varepsilon),$$

for all $t \geq t_0 + T' \geq t^*$, where t^* is the starting time of the $(2k_0 + 1)$ -th cycle, which in turn implies that $h(t, x(t)) < \varepsilon$ for all $t \geq t_0 + T'$. Suppose there are at most $2k_0$ cycles of the generalized rule between t_0 and $t_0 + T'$. Then there must exist at least one cycle lasting at least time $T + \tau$. By Proposition 2.5.4 (ii), during this cycle, at least time T is spent continuously on the minimal rule (\mathbf{R}_1) – (\mathbf{R}_3) , say on some interval $[t', t' + T] \subset [t_0, t_0 + T']$. Following how we proved the claim in part (i), we can show that there exists $t^* \in [t', t' + T]$ such that $h_0(t^*, x(t^*)) < \delta$. It follows from Proposition 2.5.4 (ii) that

$$V(t, x(t)) \leq V(t^*, x(t^*)) \leq v(h_0(t^*, x(t^*))) \leq v(\delta) < u(\varepsilon),$$

for all $t \geq t_0 + T' \geq t^*$, which implies that $h(t, x(t)) < \varepsilon$ for all $t \geq t_0 + T'$. The proof is complete. \square

2.5.3 (h_0, h) -Global Exponential Stabilization

In this subsection, we propose a stronger version of Assumption 2.5.1, and show that, under this stronger assumption, we can construct an exponentially stabilizing switching signal for system (2.1.1), based on the minimal rule (\mathbf{R}_1) – (\mathbf{R}_3) and generalized rule (\mathbf{GR}_1) – (\mathbf{GR}_3) .

Assumption 2.5.2 Assumption 2.5.1 is satisfied with \mathcal{K}_∞ -functions $a(s) = c_1 s^p$, $b(s) = c_2 s^p$, and $c(s) = c_3 s^p$, where c_1, c_2, c_3 , and p are positive constants. \square

The corresponding partitions of the time-state space are replaced by

$$\Delta_i = \left\{ (t, x) \in \mathcal{R}^+ \times \mathcal{R}^n : \dot{V}_i(t, x) \leq -c_3 h_0^p(t, x) \right\},$$

and

$$\Delta'_i = \left\{ (t, x) \in \mathcal{R}^+ \times \mathcal{R}^n : \dot{V}_i(t, x) \leq -\frac{c_3}{\zeta} h_0^p(t, x) \right\},$$

where $\zeta > 1$ can be arbitrarily chosen. The minimal rule (\mathbf{R}_1) – (\mathbf{R}_3) and the generalized rule (\mathbf{GR}_1) – (\mathbf{GR}_3) can now be employed to construct a switching signal.

The following theorem is similar to Theorem 2.5.1, except that now we have (h_0, h) -globally uniformly exponentially stability, which is a more desirable stability property in many applications.

Theorem 2.5.2 *If Assumption 2.5.2 holds, the switched system (2.1.1) is (h_0, h) -globally uniformly exponentially stable*

- (i) *under the switching signal σ constructed according to (\mathbf{R}_1) – (\mathbf{R}_3) , with the possibility that σ has a finite accumulation point t^* for its switching times, and $x(t) = 0$ for all $t \geq t^*$;*
- (ii) *under the switching signal σ constructed according to (\mathbf{GR}_1) – (\mathbf{GR}_3) , and σ is well-defined.*

Proof. (i) Assumption 2.5.2 says that

$$c_1 h^p(t, x) \leq V(t, x) \leq c_2 h_0^p(t, x), \quad \forall (t, x) \in \mathcal{R}^+ \times \mathcal{R}^n, \quad (2.5.7)$$

and

$$\frac{dV}{dt}(t, x) = \frac{\partial V}{\partial t}(t, x) + \frac{\partial V}{\partial x}(t, x) \cdot f_\alpha(t, x), \quad \forall (t, x) \in \mathcal{R}^+ \times \mathcal{R}^n,$$

which, according to the construction of σ , implies that

$$\begin{aligned} \frac{dV}{dt}(t, x(t)) &= \frac{\partial V}{\partial t}(t, x(t)) + \frac{\partial V}{\partial x}(t, x(t)) \cdot f_{\sigma(t)}(t, x(t)) \\ &\leq -\frac{c_3}{\zeta} h_0^p(t, x) \leq -\frac{c_3}{\zeta c_2} V(t, x(t)), \quad \forall t \geq t_0. \end{aligned}$$

Therefore,

$$V(t, x(t)) \leq V(t_0, x_0) e^{-\frac{c_3}{\zeta c_2}(t-t_0)}, \quad \forall t \geq t_0, \quad (2.5.8)$$

and

$$h(t, x(t)) \leq \left(\frac{c_2}{c_1}\right)^{1/p} h_0(t_0, x_0) e^{-\frac{c_3}{\zeta c_2 p}(t-t_0)}, \quad \forall t \geq t_0,$$

i.e., system (2.1.1) is (h_0, h) -globally uniformly exponentially stable.

(ii) Note that (2.5.8) gives an estimate of $V(t, x(t))$ in terms of an exponential decay. We show that under the assumption of the theorem, each nontrivial cycle (by which we mean a cycle starting with $V(t_0, x(t_0)) \neq 0$) of the generalized rule has an upper bound. Suppose there exists a nontrivial cycle with its duration strictly greater than τ and this cycle contains an interval of the form $[t' - \tau, t' + T]$, where $T > 0$. According to Proposition 2.5.4 (iv), on $[t', t' + T]$, the minimal rule is engaged. Similar to the argument in part (i), we can show

$$V(t' + T, x(t' + T)) \leq V(t', x(t')) e^{-\frac{c_3}{\zeta c_2} T}. \quad (2.5.9)$$

Moreover, during the minimal rule time, we have $(t, x(t)) \in \overline{\mathcal{D}_{k_0-1} \cup \mathcal{D}_{k_0}}$, and the cycle would end once $(t, x(t))$ hits the boundary of \mathcal{D}_{k_0-2} (since the minimal cycle time is already

achieved). Therefore, we must have in the same time

$$V(t', x(t')) \leq 2^{k_0+1}, \quad V(t' + T, x(t' + T)) \geq 2^{k_0-1},$$

which, according to (2.5.9), implies that

$$T \leq \frac{\zeta c_2 \ln 2}{c_3},$$

which further implies that a cycle lasts for at most $\hat{\tau} = \tau + \frac{\zeta c_2 \ln 2}{c_3}$ unit of time. Recall that Proposition 2.5.4 (iii) shows the value of $V(t, x(t))$ decreases at least by half every two cycles. We claim that

$$V(t, x(t)) \leq MV(t_0, x_0)e^{-\mu(t-t_0)}, \quad \forall t \geq t_0,$$

where $\mu = \frac{\ln 2}{2\hat{\tau}}$ and $M = e^{2\mu\hat{\tau}}$ are positive constants independent of t_0 and x_0 . We denote the consecutive nontrivial cycles by I_1, I_2, \dots , and $\tau_1 = t_0, \tau_2, \dots$ are the corresponding starting times. On I_1 and I_2 , we clearly have, from Proposition 2.5.4 (ii),

$$V(t, x(t)) \leq V(t_0, x_0) \leq MV(t_0, x_0)e^{-\mu(t-t_0)}.$$

It follows from Proposition 2.5.4 (ii) and (iii) that, on I_3 and I_4 , we have

$$\begin{aligned} V(t, x(t)) &\leq V(\tau_3, x(\tau_3)) \leq \frac{1}{2} V(t_0, x_0) \leq \frac{1}{2} MV(t_0, x_0)e^{-\mu(\tau_3-t_0)} \\ &\leq \frac{1}{2} e^{2\mu\hat{\tau}} MV(t_0, x_0)e^{-\mu(t-t_0)} = MV(t_0, x_0)e^{-\mu(t-t_0)}. \end{aligned}$$

This procedure can be carried on for all subsequent nontrivial cycles. The proof can be completed by induction. Note that, if there exists a subsequent trivial cycle, i.e., $V(t, x(t))$ becomes 0 in a finite time, it follows from the minimal rule and Assumption 2.5.2 that $V(t, x(t))$ stays 0 for all future time, and therefore the claim still holds. \square

2.5.4 Examples

We shall discuss a few examples in this subsection to illustrate our results obtained previously in this section.

The purpose of the following example is to show that the minimal rule can exhibit Zeno behavior, while the generalized rule can avoid it.

Example 2.5.1 Consider two subsystems given by

$$x' = f_1(t, x) = \begin{Bmatrix} -2x_1^{\frac{1}{3}} \\ x_2^{\frac{1}{3}} \end{Bmatrix}, \quad (2.5.10)$$

and

$$x' = f_2(t, x) = \begin{Bmatrix} x_1^{\frac{1}{3}} \\ -2x_2^{\frac{1}{3}} \end{Bmatrix}. \quad (2.5.11)$$

Both subsystems are decoupled and admit explicit solutions. However, since both subsystems have non-Lipschitz vector fields for $x_1 = 0$ and $x_2 = 0$, solutions are not unique for both subsystems. Particularly, the solution for subsystem (2.5.10) with initial condition $x(t_0) = x_0$, where $x_0 = [x_{10} \ x_{20}]$, is given by

$$x_1^{\frac{2}{3}} = \begin{cases} 0, & t \geq t_0 + \frac{3}{4}x_{10}^{\frac{2}{3}}, \\ x_{10}^{\frac{2}{3}} - \frac{4}{3}(t - t_0), & t_0 \leq t < t_0 + \frac{3}{4}x_{10}^{\frac{2}{3}}, \end{cases}$$

$$x_2^{\frac{2}{3}} = \begin{cases} \begin{cases} 0, & t \geq t_0, \quad x_{20} = 0, \\ \frac{2}{3}(t - t_0), & t \geq t_0, \quad x_{20} \neq 0, \end{cases} \\ x_{20}^{\frac{2}{3}} + \frac{2}{3}(t - t_0), & t \geq t_0, \quad x_{20} \neq 0, \end{cases}$$

and the solution for subsystem (2.5.11) with the same initial condition is given by

$$x_1^{\frac{2}{3}} = \begin{cases} \begin{cases} 0, & t \geq t_0, \quad x_{10} = 0, \\ \frac{2}{3}(t - t_0), & t \geq t_0, \quad x_{10} \neq 0, \end{cases} \\ x_{10}^{\frac{2}{3}} + \frac{2}{3}(t - t_0), & t \geq t_0, \quad x_{10} \neq 0, \end{cases}$$

$$x_2^{\frac{2}{3}} = \begin{cases} 0, & t \geq t_0 + \frac{3}{4}x_{20}^{\frac{2}{3}}, \\ x_{20}^{\frac{2}{3}} - \frac{4}{3}(t - t_0), & t_0 \leq t < t_0 + \frac{3}{4}x_{20}^{\frac{2}{3}}. \end{cases}$$

Therefore, subsystem (2.5.10) admits multiple solutions when $x_{20} = 0$ and subsystem (2.5.11) admits multiple solutions when $x_{10} = 0$.

It is clear that, for both subsystems, one of the components of a nontrivial solution goes to infinity and the other goes to 0 in finite time. Therefore, both subsystems are unstable. To apply the switching stabilization method, one can let

$$f(t, x) = \frac{1}{2}f_1(t, x) + \frac{1}{2}f_2(t, x) = -\frac{1}{2} \begin{Bmatrix} x_1^{\frac{1}{3}} \\ x_2^{\frac{1}{3}} \end{Bmatrix}$$

and $V(t, x) = x_1^2 + x_2^2$. Then

$$\frac{\partial V}{\partial x}(t, x) \cdot f(t, x) = -x_1^{\frac{4}{3}} - x_2^{\frac{4}{3}} \leq -V^{\frac{2}{3}}(t, x),$$

for all $(t, x) \in \mathcal{R}^+ \times \mathcal{R}^n$, and the set Γ_0 in Assumption 2.5.1 is given by $\Gamma_0 = \mathcal{R}^+ \times \{0\}$. Following the explicit solutions, **solutions for (2.5.10) and (2.5.11), starting from $(t_0, 0)$, may leave the origin through the x_2 -axis ($x_1 = 0$) and the x_1 -axis ($x_2 = 0$)**, respectively. Therefore, item (i) of Assumption 2.5.1 does not hold. Nevertheless, in the following, we can still apply the switching stabilization scheme to show that a switching solution will converge to the origin, by following the minimal rule and the generalized rule. Moreover, we will discuss the differences between the minimal rule and the generalized rule.

We choose $h_0 = h = |x|$, $a(s) = b(s) = s^2$, and $c(s) = s^{\frac{4}{3}}$, where $s > 0$. With $\zeta = 2$, one can define

$$\begin{aligned}\Omega'_1 &= \{(t, x) \in \mathcal{R}^+ \times \mathcal{R}^n : \frac{\partial V}{\partial x}(t, x) \cdot f_1(t, x) \leq -\frac{1}{2}|x|^{\frac{4}{3}}\} \\ &= \{(t, x) \in \mathcal{R}^+ \times \mathcal{R}^n : -8x_1^{\frac{4}{3}} + 4x_2^{\frac{4}{3}} + |x|^{\frac{4}{3}} \leq 0\} \\ &= \{(t, x) \in \mathcal{R}^+ \times \mathcal{R}^n : |x_2| \leq c|x_1|\},\end{aligned}$$

and

$$\begin{aligned}\Omega'_2 &= \{(t, x) \in \mathcal{R}^+ \times \mathcal{R}^n : \frac{\partial V}{\partial x}(t, x) \cdot f_2(t, x) \leq -\frac{1}{2}|x|^{\frac{4}{3}}\} \\ &= \{(t, x) \in \mathcal{R}^+ \times \mathcal{R}^n : 4x_1^{\frac{4}{3}} - 8x_2^{\frac{4}{3}} + |x|^{\frac{4}{3}} \leq 0\} \\ &= \{(t, x) \in \mathcal{R}^+ \times \mathcal{R}^n : |x_1| \leq c|x_2|\},\end{aligned}$$

where $c = 1.3548\dots > 1$ is a root of the equation $4c^{4/3} + (1 + c^2)^{2/3} - 8 = 0$. A switching signal can now be constructed by the minimal rule (\mathbf{R}_1) – (\mathbf{R}_3) and the generalized rule (\mathbf{GR}_1) – (\mathbf{GR}_3) .

Discussion. In the following, we discuss in more detail how the minimal rule and the generalized rule make a switching solution converge to the origin in this particular example.

First, we show that a switching signal constructed using the minimal rule actually exhibits Zeno behavior as a solution converges to the origin. It is easy to check that the minimal rule implies that

$$\frac{dV(t, x(t))}{dt} \leq -\frac{1}{2}V^{\frac{2}{3}}(t, x(t)). \quad (2.5.12)$$

We suppose that $V(t_0, x_0) \neq 0$ (i.e., we consider a solution starting away from the origin). Integrating the differential inequality (2.5.12) gives

$$V^{\frac{1}{3}}(t, x(t)) \leq V^{\frac{1}{3}}(t_0, x_0) - \frac{1}{6}(t - t_0), \quad t \geq t_0, \quad (2.5.13)$$

as long as $V(t, x(t)) \neq 0$, which shows that $V(t, x(t))$ becomes 0 in finite time (so does $|x|$). Moreover, based on the explicit solutions, we know that a solution of subsystem (2.5.10) approaches the x_2 -axis and a solution of subsystem (2.5.11) approaches the x_1 -axis, both in finite time. In neither case can the solution converge to the origin, provided that the solution does not start from a point not on the axes. Note that Ω'_1 does not contain the x_2 -axis except the origin and Ω'_2 does not contain the x_1 -axis except the origin. Following the minimal rule, a nontrivial solution eventually enters the common region $\Omega'_1 \cap \Omega'_2$ and remains in the region for all future time. Therefore, in order that a solution converges to the origin in finite time, as implied by (2.5.13), a switching solution has to switch between the two subsystems infinitely many times in a finite time (i.e., exhibits Zeno behavior).

Second, we can show that, in this example, **a switching solution generated by the generalized rule may still enjoy the property of converging to the origin in finite time**, while we know from Proposition 2.5.4 that the generalized rule can avoid Zeno behavior.

During the minimal rule time, inequality (2.5.13) shows that, if $V(t_0, x(t_0))$ is sufficiently small, where t_0 is the starting time of any cycle with $(t_0, x(t_0)) \in \mathcal{D}_{k_0}$ for some $k_0 \in \mathcal{Z}$, $V(t, x(t))$ would decrease faster than any given exponential rate and therefore it takes less than τ unit of time for $V(t, x(t))$ to reach the boundary of \mathcal{D}_{k_0-2} . Therefore, by the generalized rule, following a portion of minimal rule time, there must be a portion of wandering time, the starting time of which is denoted by t_1 . Without loss of generality, suppose that $x_1(t_1, x(t_1)) \neq 0$, $x_2(t_1, x(t_1)) \neq 0$, and $\sigma(t_1) = 1$, i.e., the first mode is maintained during this portion of wandering time. The wandering time ends only if $\tau - (t_1 - t_0)$ unit of time has elapsed or $V(t, x(t))$, starting from $V(t_1, x(t_1)) = 2^{k_0-1}$, reaches \mathcal{D}_{k_0} , i.e., $V(t_2, x(t_2)) = 2^{k_0}$ for some $t_2 > t_1$, whichever occurs first. If $|x_1(t_1, x(t_1))|$ is sufficiently small, we claim that

Claim. $(t, x(t))$ will hit the x_2 -axis first before $V(t, x(t))$ increases to 2^{k_0} .

Proof of the Claim. For sufficiently small $|x_1(t_1, x(t_1))|$, the explicit solution of (2.5.10) implies that it will not take $\tau - (t_1 - t_0)$ unit of time for $x_1(t, x(t))$ to become 0. Moreover, it can be easily computed that, once $x_1(\bar{t}, x(\bar{t}))$ becomes 0 for some $\bar{t} > t_1$,

$$V(\bar{t}, x(\bar{t})) = \left\{ x_2^{\frac{2}{3}}(t_1, x(t_1)) + \frac{1}{2} x_1^{\frac{2}{3}}(t_1, x(t_1)) \right\}^3, \quad (2.5.14)$$

while

$$V(t_1, x(t_1)) = x_2^2(t_1, x(t_1)) + x_1^2(t_1, x(t_1)) = 2^{k_0-1}. \quad (2.5.15)$$

Following (2.5.10), we have

$$\frac{dV(t, x(t))}{dt} = -4x_1^{\frac{4}{3}}(t, x(t)) + 2x_2^{\frac{4}{3}}(t, x(t)), \quad t \in (t_1, \bar{t}),$$

which shows that the dynamic of $V(t, x(t))$ during the interval $[t_1, \bar{t}]$ is characterized by a possible initial decrease and a subsequent increase in the value of $V(t, x(t))$. Particularly, we know that the maximum of $V(t, x(t))$ during the interval $[t_1, \bar{t}]$ is attained either at $t = t_1$ or $t = \bar{t}$. Therefore, if we can check

$$V(\bar{t}, x(\bar{t})) < 2V(t_1, x(t_1)) = 2^{k_0}, \quad (2.5.16)$$

then the claim must be true. In view of (2.5.14) and (2.5.15), inequality (2.5.16) would follow from

$$(a + \frac{1}{2}b)^3 < 2a^3 + 2b^3, \quad a > 0, \quad b > 0, \quad (2.5.17)$$

which can be easily proved using Young's inequality about products². Therefore, (2.5.17) implies that (2.5.16) is true and the claim is proved.

The following dynamics of the switched system by the generalized rule *follows two possibilities*. While $V(t, x(t))$ continues to rise until it hits 2^{k_0} , the minimal rule will be activated and the solution will continue in the second mode. Since the solution is now on the x_2 -axis ($x_1 = 0$), the explicit solutions of the second subsystem (2.5.11) can either stay on the x_2 -axis and follow the second mode for all future time (as simulated in Figure 2.8), or it can exit the x_2 -axis by following $x_1(t) = \pm[\frac{2}{3}(t - t^*)]^{\frac{3}{2}}$, where t^* is the time of exit. In the former case, we can see from the explicit solutions that x_2 converges to 0 in finite time (hence $\mathbf{x}(t)$ *converges to the origin in finite time*). In the latter case, eventually the solution will hit the boundary of Ω'_2 and the first mode will be activated either immediately or after a portion of wandering time. The solution will go on according to the generalized rule. While the trajectories may behave differently depending on whether or not they would exit the axes, the proof of Theorem 2.5.2 still guarantees that the solutions converge to the origin.

Simulation. In Figure 2.8, typical switching solutions with the same initial condition are shown. Both the minimal rule switching and generalized rule switchings with different cycle times are plotted. It can be observed that, in this particular example, generalized rule switchings can lead to convergence of the solution to the origin in finite time, by exiting the

²Applying Young's inequality, $xy \leq x^p/p + y^q/q$, where $x \geq 0$, $y \geq 0$, $1/p + 1/q = 1$ with $p > 0$ and $q > 0$, to the products $(a^2)(3b/2)$ and $(a)(3b^2/4)$, one can prove (2.5.17).

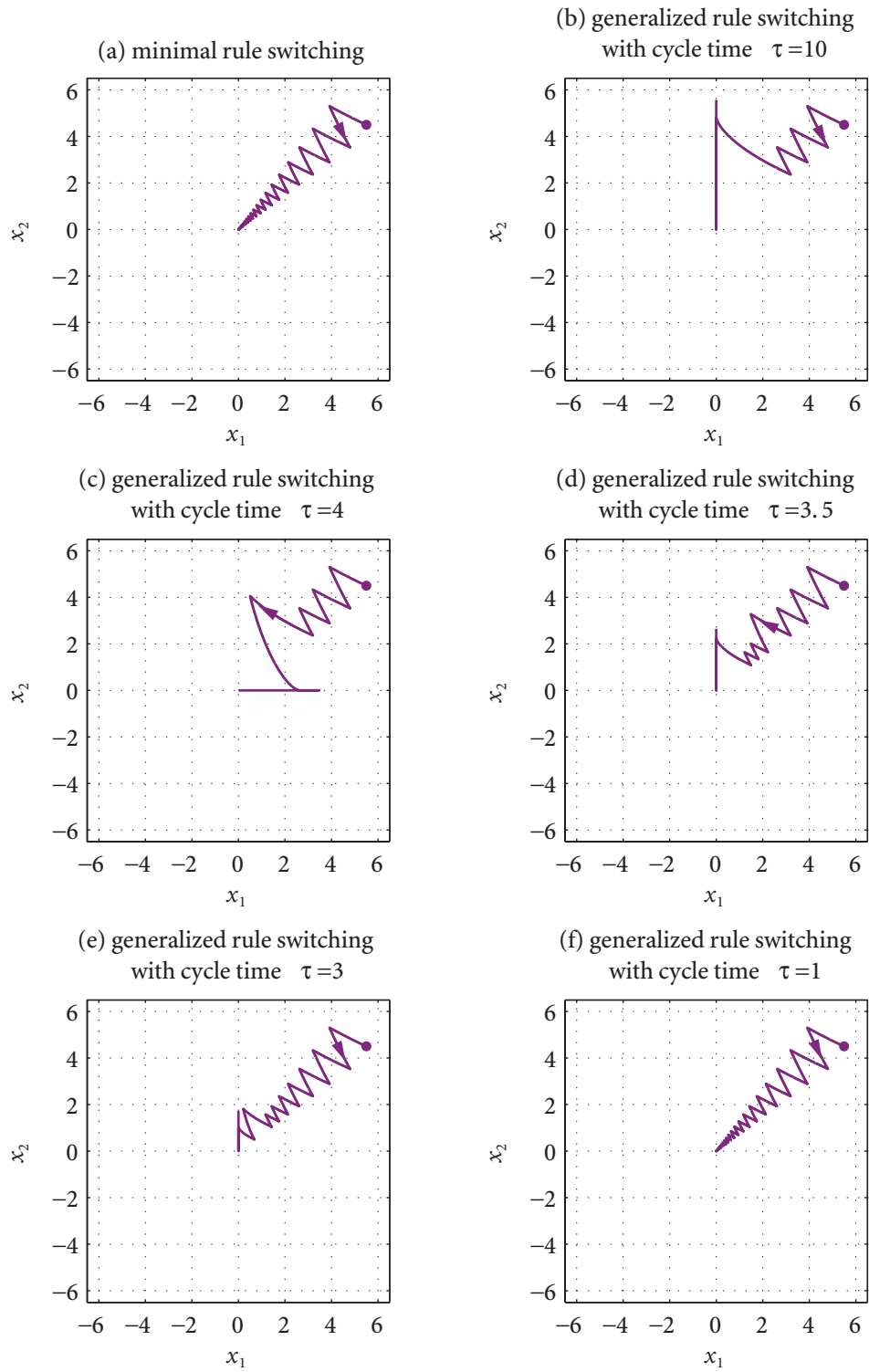

Figure 2.8 Stabilized switching solutions with initial data $[5.5 \ 4.5]$ at $t_0 = 0$ for the switched system given by (2.5.10) and (2.5.11).

minimal rule switching and converging to one of the axes first, after only a finite number of switchings. As discussed above, the simulations only show the trajectories that stay on the axes once they enter them. \square

Remark 2.5.5 As pointed out in Remark 2.5.1, under the special case of $h_0 = h = |x|$, the positive invariance of the set Γ_0 imposed by Assumption 2.5.1 translates to that the trivial solution $x = 0$ is the unique solution for each of the subsystems on $[t_0, \infty)$ with $x(t_0) = 0$. This is certainly *not* the case for this particular example. Nevertheless, by focusing on only convergence of solutions to the origin, we present this example to show that the minimal rule can exhibit Zeno behavior in some cases, and the generalized rule can be used to avoid this. \square

Remark 2.5.6 As shown in Figure 2.8, if we choose the minimal cycle time τ sufficiently small, switching solutions generated by the minimal rule (\mathbf{R}_1) – (\mathbf{R}_3) and the generalized rule (\mathbf{GR}_1) – (\mathbf{GR}_3) are indistinguishable from a finite precision simulation. Therefore, in the following examples, simulations are performed for the minimal rule switchings only. \square

Example 2.5.2 (Lyapunov Stability) Consider two subsystems given by

$$x' = f_1(t, x) = \begin{Bmatrix} 2x_1 + 2x_2^3 \\ -2x_2 + x_1x_2^2 \end{Bmatrix}, \quad (2.5.18)$$

and

$$x' = f_2(t, x) = \begin{Bmatrix} -3x_1 - x_2^3 \\ x_2 - 2x_1x_2^2 \end{Bmatrix}. \quad (2.5.19)$$

By linearization near the origin, it can be shown that both subsystems are locally unstable. To apply the switching stabilization method, one can let

$$f(t, x) = \frac{1}{2}f_1(t, x) + \frac{1}{2}f_2(t, x) = \frac{1}{2} \begin{Bmatrix} -x_1 + x_2^3 \\ -x_2 - x_1x_2^2 \end{Bmatrix}$$

and $V(t, x) = x_1^2 + x_2^2$. Then

$$\frac{\partial V}{\partial x}(t, x) \cdot f(t, x) = -x_1^2 - x_2^2 = -V(t, x),$$

for all $(t, x) \in \mathcal{R}^+ \times \mathcal{R}^n$, and the set Γ_0 in Assumption 2.5.1 is given by $\Gamma_0 = \mathcal{R}^+ \times \{0\}$. A solution for either (2.5.18) or (2.5.19), starting from $(t_0, 0)$, certainly stays 0 for all $t \geq t_0$. It

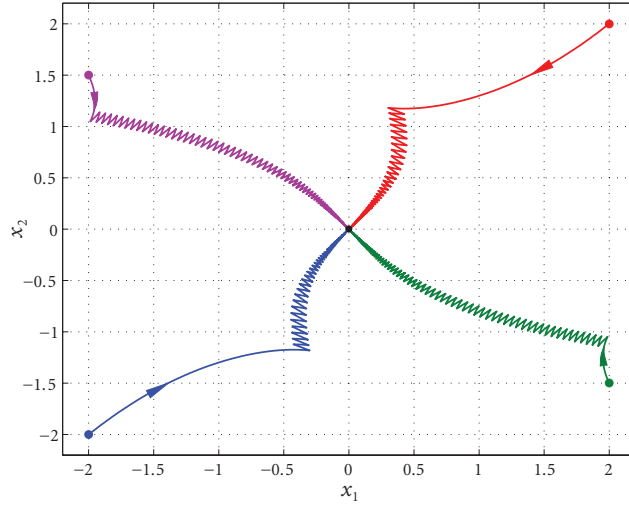

Figure 2.9 Stabilized switching solutions with initial data $[2 \ 2]$, $[-2 \ -2]$, $[-2 \ 1.5]$, and $[2 \ -1.5]$ at $t_0 = 0$ for the switched system given by (2.5.18) and (2.5.19).

is easy to see that Assumption 2.5.2 is satisfied with $h_0 = h = |x|$, $c_1 = c_2 = c_3 = 1$, and $p = 2$. By choosing $\zeta = 2$, one can define

$$\begin{aligned} \Delta'_1 &= \{(t, x) \in \mathcal{R}^+ \times \mathcal{R}^n : \frac{\partial V}{\partial x}(t, x) \cdot f_1(t, x) \leq -\frac{1}{2} |x|^2\} \\ &= \{(t, x) \in \mathcal{R}^+ \times \mathcal{R}^n : 9x_1^2 - 7x_2^2 + 12x_1x_2^3 \leq 0\}, \end{aligned}$$

and

$$\begin{aligned} \Delta'_2 &= \{(t, x) \in \mathcal{R}^+ \times \mathcal{R}^n : \frac{\partial V}{\partial x}(t, x) \cdot f_2(t, x) \leq -\frac{1}{2} |x|^2\} \\ &= \{(t, x) \in \mathcal{R}^+ \times \mathcal{R}^n : -11x_1^2 + 5x_2^2 - 12x_1x_2^3 \leq 0\}. \end{aligned}$$

A switching signal can now be constructed by the minimal rule (\mathbf{R}_1) – (\mathbf{R}_3) and the generalized rule (\mathbf{GR}_1) – (\mathbf{GR}_3) . Theorem 2.5.2 then guarantees the resulting switched system is (h_0, h) -globally uniformly exponentially stable. Since h_0 and h are both chosen to be $|x|$, the (h_0, h) -stability concluded here is actually equivalent to Lyapunov stability.

Simulation. Typical switching solutions with various initial conditions are shown in Figure 2.9. It is observed that the switching solutions converge to the origin as expected. \square

Example 2.5.3 (Partial Stability) Consider two subsystems given by

$$x' = f_1(t, x) = \begin{Bmatrix} -3x_1 + x_2 \\ x_2 \end{Bmatrix}, \quad (2.5.20)$$

and

$$x' = f_2(t, x) = \begin{Bmatrix} 2x_1 - x_2 + x_1x_2e^{-t} \\ -x_1^2 - x_2e^t \end{Bmatrix}. \quad (2.5.21)$$

By linearization near the origin, it can be shown that both subsystems are locally unstable. To apply the switching stabilization method, one can let

$$f(t, x) = \frac{1}{2}f_1(t, x) + \frac{1}{2}f_2(t, x) = \frac{1}{2} \begin{Bmatrix} -x_1 + x_1x_2e^{-t} \\ x_2 - x_1^2 - x_2e^t \end{Bmatrix}$$

and $V(t, x) = x_1^2 + x_2^2e^{-t}$. Then

$$\frac{\partial V}{\partial t}(t, x) + \frac{\partial V}{\partial x}(t, x) \cdot f(t, x) = -x_1^2 - x_2^2,$$

for all $(t, x) \in \mathcal{R}^+ \times \mathcal{R}^n$, and the set Γ_0 in Assumption 2.5.1 is given by $\Gamma_0 = \mathcal{R}^+ \times \{0\}$. A solution for either of the two subsystems (2.5.20) and (2.5.21), starting from $(t_0, 0)$, certainly stays 0 for all $t \geq t_0$. It is easy to see that Assumption 2.5.2 is satisfied with $h_0 = |x|$, $h = |x_1|$, $p = 2$, and $c_1 = c_2 = c_3 = 1$. By choosing $\zeta = 2$, one can define

$$\begin{aligned} \Delta'_1 &= \left\{ (t, x) \in \mathcal{R}^+ \times \mathcal{R}^n : \frac{\partial V}{\partial t}(t, x) + \frac{\partial V}{\partial x}(t, x) \cdot f_1(t, x) \leq -\frac{1}{2}|x|^2 \right\} \\ &= \left\{ (t, x) \in \mathcal{R}^+ \times \mathcal{R}^n : -11x_1^2 + x_2^2 + 2x_2^2e^{-t} + 4x_1x_2 \leq 0 \right\}, \end{aligned}$$

and

$$\begin{aligned} \Delta'_2 &= \left\{ (t, x) \in \mathcal{R}^+ \times \mathcal{R}^n : \frac{\partial V}{\partial t}(t, x) + \frac{\partial V}{\partial x}(t, x) \cdot f_2(t, x) \leq -\frac{1}{2}|x|^2 \right\} \\ &= \left\{ (t, x) \in \mathcal{R}^+ \times \mathcal{R}^n : 9x_1^2 - 3x_2^2 - 2x_2^2e^{-t} - 4x_1x_2 \leq 0 \right\}. \end{aligned}$$

A switching signal can now be constructed by the minimal rule (\mathbf{R}_1) – (\mathbf{R}_3) and the generalized rule (\mathbf{GR}_1) – (\mathbf{GR}_3) . Theorem 2.5.2 then guarantees the resulting switched system is (h_0, h) -globally uniformly exponentially stable. Since $h_0 = |x|$ and $h = |x_1|$, the (h_0, h) -stability concluded here is equivalent to partial stability of the first component. \square

Example 2.5.4 (Orbital Stability) Consider two subsystems given by

$$x' = f_1(t, x) = \begin{cases} -x_2 + 3(1 - x_1^2 - x_2^2)x_1 \\ x_1 - (1 - x_1^2 - x_2^2)x_2 \end{cases}, \quad (2.5.22)$$

and

$$x' = f_2(t, x) = \begin{cases} -x_2 - (1 - x_1^2 - x_2^2)x_1 \\ x_1 + 3(1 - x_1^2 - x_2^2)x_2 \end{cases}. \quad (2.5.23)$$

It is easy to see that $x = 0$ is a trivial solution for both subsystems. Moreover, $x = (\cos t, \sin t)$ is a periodic solution for both subsystems. By linearization near the origin, it can be shown that both subsystems are locally unstable. To apply the stabilization method to study the periodic solution, one can let

$$f(t, x) = \frac{1}{2}f_1(t, x) + \frac{1}{2}f_2(t, x) = \begin{cases} -x_2 + (1 - x_1^2 - x_2^2)x_1 \\ x_1 + (1 - x_1^2 - x_2^2)x_2 \end{cases}$$

and $V(t, x) = (1 - x_1^2 - x_2^2)^2$. Then

$$\frac{\partial V}{\partial x}(t, x) \cdot f(t, x) = -4(1 - x_1^2 - x_2^2)^2(x_1^2 + x_2^2), \quad (2.5.24)$$

for all $(t, x) \in \mathcal{R}^+ \times \mathcal{R}^n$, and the set Γ_0 in Assumption 2.5.1 is given by $\Gamma_0 = \mathcal{R}^+ \times \{(x_1, x_2) : x_1^2 + x_2^2 = 1\}$. A solution for either of the two subsystems (2.5.22) and (2.5.23), starting from (t_0, x_0) with $x_{10}^2 + x_{20}^2 = 1$, will stay in Γ_0 for all $t \geq t_0$. To see this, we observe that $x = (\cos t, \sin t)$ is a periodic solution for both subsystems and it is unique with respect any initial condition on Γ_0 (the argument is that both vector fields are locally Lipschitz in x). If one chooses $h_0 = h = |1 - x_1^2 - x_2^2|$, then (h_0, h) -stability is equivalent to stability of the periodic solution $(\cos t, \sin t)$. Since $x = 0$ is a trivial solution of both subsystems, one cannot expect global attraction of the periodic solution. However, it can be shown that (2.5.24) implies Assumption 2.5.2, except in an arbitrarily small neighborhood of the origin. Actually, one has

$$\frac{\partial V}{\partial x}(t, x) \cdot f(t, x) \leq -4\varepsilon(1 - x_1^2 - x_2^2)^2, \quad (2.5.25)$$

for all $(t, x) \in \mathcal{R}^+ \times \mathcal{R}^n \setminus B(\varepsilon)$, where $\varepsilon > 0$ can be arbitrarily chosen. Moreover, by virtue of (2.5.24), any solution starting from $\mathcal{R}^n \setminus B(\varepsilon)$ remains in $\mathcal{R}^n \setminus B(\varepsilon)$ for all $t \geq t_0$. Similar argument as in the proof of Theorem 2.5.2 can show any solution starting from $\mathcal{R}^n \setminus B(\varepsilon)$ is attracted to the periodic solution $(\cos t, \sin t)$. It is easy to see that Assumption

2.5.2 is satisfied with $h_0 = h = |1 - x_1^2 - x_2^2|$, $p = 2$, $c_1 = c_2$, and $c_3 = 4\varepsilon$, for all $(t, x) \in \mathcal{R}^+ \times \mathcal{R}^n \setminus B(\varepsilon)$. To construct a stabilizing switching signal, one can define, by choosing $\zeta = 2$,

$$\begin{aligned}\Delta'_1 &= \left\{ (t, x) \in \mathcal{R}^+ \times \mathcal{R}^n : \frac{\partial V}{\partial x}(t, x) \cdot f_1(t, x) \leq -2h_0^2 \cdot (x_1^2 + x_2^2) \right\} \\ &= \left\{ (t, x) \in \mathcal{R}^+ \times \mathcal{R}^n : |x_1| \geq \sqrt{\frac{3}{5}} |x_2| \text{ or } x_1^2 + x_2^2 = 1 \right\},\end{aligned}$$

and

$$\begin{aligned}\Delta'_2 &= \left\{ (t, x) \in \mathcal{R}^+ \times \mathcal{R}^n : \frac{\partial V}{\partial x}(t, x) \cdot f_2(t, x) \leq -2h_0^2 \cdot (x_1^2 + x_2^2) \right\} \\ &= \left\{ (t, x) \in \mathcal{R}^+ \times \mathcal{R}^n : |x_2| \geq \sqrt{\frac{3}{5}} |x_1| \text{ or } x_1^2 + x_2^2 = 1 \right\}.\end{aligned}$$

A switching signal can now be constructed by the minimal rule (\mathbf{R}_1) – (\mathbf{R}_3) and the generalized rule (\mathbf{GR}_1) – (\mathbf{GR}_3) . Theorem 2.5.2 then guarantees the resulting switched system is (h_0, h) -globally uniformly exponentially stable. Since $h_0 = h = |1 - x_1^2 - x_2^2|$, the (h_0, h) -stability concluded here is equivalent to stability of the periodic solution $(\cos t, \sin t)$.

Simulation. The phase portraits for both subsystems are shown in Figure 2.10. It can be observed that the periodic solution is unstable for both subsystems. The switching domains Δ'_1 and Δ'_2 are shown in Figure 2.11. Typical switching solutions with various initial conditions are shown in Figure 2.12. It is observed that the switching solutions converge to the periodic solution as expected. \square

Example 2.5.5 (Stability of Conditionally Invariant Set) Consider two subsystems given by

$$x' = f_1(t, x) = \begin{Bmatrix} -x_1 - 2x_2 e^{-t} \\ 2x_1 \\ x_3 \sin t \end{Bmatrix}, \quad (2.5.26)$$

and

$$x' = f_2(t, x) = \begin{Bmatrix} -x_1 \sin^2 x_3 \\ -x_2 e^t \\ -x_1 e^{-t} + x_2 \cos t \end{Bmatrix}. \quad (2.5.27)$$

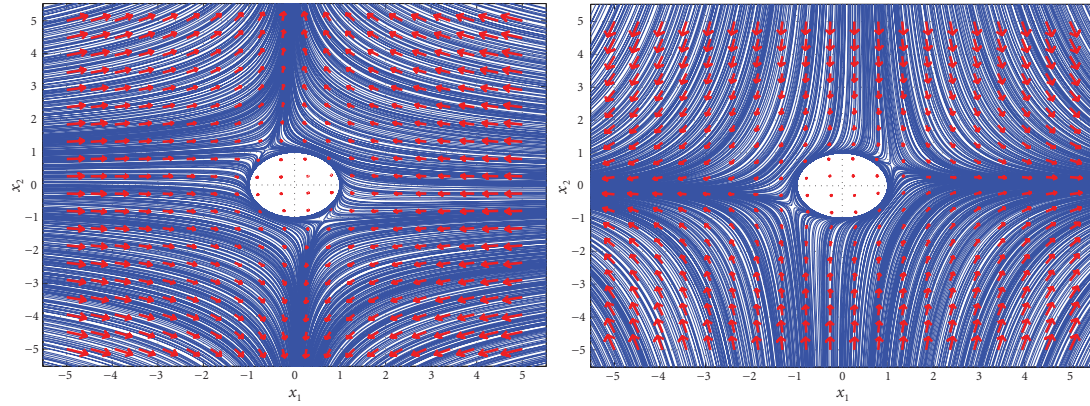

Figure 2.10 Phase portraits for subsystems (2.5.22) (left) and (2.5.23) (right).

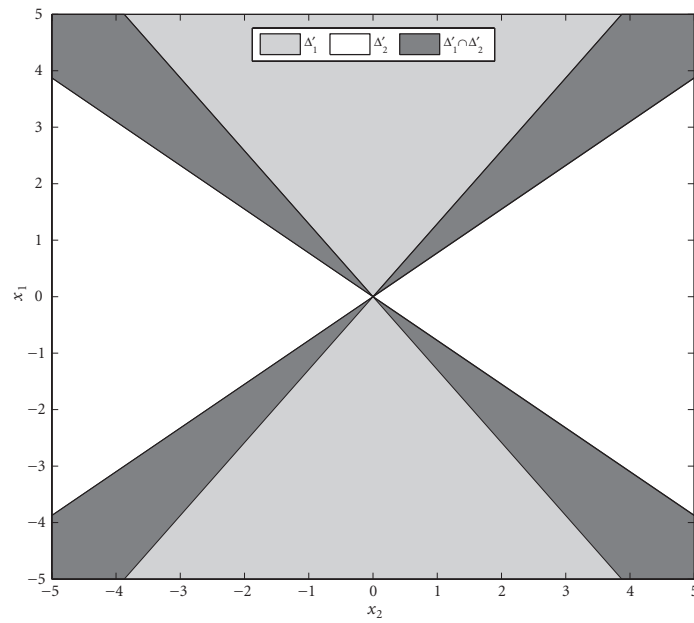

Figure 2.11 Stabilizing switching domains for the switched system given by (2.5.22) and (2.5.23).

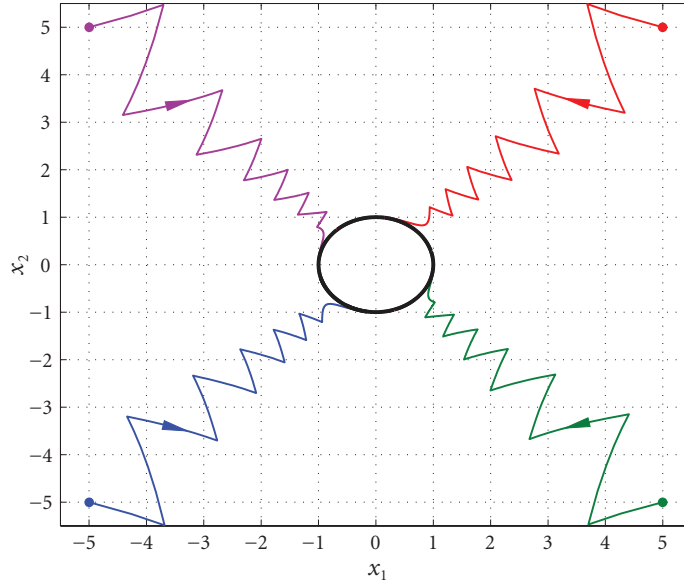

Figure 2.12 Stabilized switching solutions with initial data $[5 \ 5]$, $[5 \ -5]$, $[-5 \ 5]$, and $[-5 \ -5]$ at $t_0 = 0$.

Let

$$f(t, x) = \frac{1}{2}f_1(t, x) + \frac{1}{2}f_2(t, x) = \frac{1}{2} \begin{Bmatrix} -x_1(1 + \sin^2 x_3) - 2x_2 e^{-t} \\ 2x_1 - x_2 e^t \\ -x_1 e^{-t} + x_2 \cos t + x_3 \sin t \end{Bmatrix}$$

$V(t, x) = x_1^2 + x_2^2 e^{-t}$, $h(t, x) = d(x, B)$, and $h_0(t, x) = d(x, A)$, where $A = \{x \in \mathcal{R}^3 : x_1 = x_2 = 0\}$ and $B = \{x \in \mathcal{R}^3 : x_1 = 0\}$. Therefore, $h_0(t, x) = x_1^2 + x_2^2$ and $h(t, x) = x_1^2$. It is easy to see that $A \subset B$,

$$h^2(t, x) \leq V(t, x) \leq h_0^2(t, x),$$

and

$$\frac{\partial V}{\partial t}(t, x) + \frac{\partial V}{\partial x}(t, x) \cdot f(t, x) \leq -h_0^2(t, x),$$

for all $(t, x) \in \mathcal{R}^+ \times \mathcal{R}^3$, and the set Γ_0 in Assumption 2.5.1 is given by $\Gamma_0 = \mathcal{R}^+ \times \{(x_1, x_2, x_3) : x_1 = x_2 = 0\}$. A solution for either of the two subsystems (2.5.26) and (2.5.27), starting from (t_0, x_0) with $x_{10} = x_{20} = 0$, will stay in Γ_0 for all $t \geq t_0$. Actually, for (2.5.26), the equations for the first two components and the third one are decoupled. It is easy to see that $x_1 = 0$ and $x_2 = 0$ is the unique solution with respect to $x_{10} = x_{20} = 0$. Therefore, a solution will stay in Γ_0 for all $t \geq t_0$. For (2.5.26), one can

observe a unique solution $(0, 0, x_{30})$ for $x_{10} = x_{20} = 0$. Therefore, Assumption 2.5.2 is satisfied with $c_1 = c_2 = c_3 = 1$ and $p = 2$. By choosing $\zeta = 2$, one can define

$$\begin{aligned}\Delta'_1 &= \left\{ (t, x) \in \mathcal{R}^+ \times \mathcal{R}^n : \frac{\partial V}{\partial t}(t, x) + \frac{\partial V}{\partial x}(t, x) \cdot f_1(t, x) \leq -\frac{1}{2}h_0^2(t, x) \right\} \\ &= \{(t, x) \in \mathcal{R}^+ \times \mathcal{R}^n : -3x_1^2 + x_2^2 - 2x_2^2e^{-t} \leq 0\},\end{aligned}$$

and

$$\begin{aligned}\Delta'_2 &= \left\{ (t, x) \in \mathcal{R}^+ \times \mathcal{R}^n : \frac{\partial V}{\partial t}(t, x) + \frac{\partial V}{\partial x}(t, x) \cdot f_2(t, x) \leq -\frac{1}{2}h_0^2(t, x) \right\} \\ &= \left\{ (t, x) \in \mathcal{R}^+ \times \mathcal{R}^n : x_1^2 - 4x_1^2 \sin^2 x_3 - 3x_2^2 - 2x_2^2e^{-t} \leq 0 \right\}.\end{aligned}$$

A switching signal can be constructed by the minimal rule (\mathbf{R}_1) – (\mathbf{R}_3) and the generalized rule (\mathbf{GR}_1) – (\mathbf{GR}_3) . Theorem 2.5.2 guarantees that the resulting switched system is (h_0, h) -globally uniformly exponentially stable. Since $h(t, x) = d(x, B)$ and $h_0(t, x) = d(x, A)$, the (h_0, h) -stability concluded here is equivalent to stability of conditionally invariant set B with respect to A (see [100]). \square

2.6 Summary

In this chapter, we have presented a general formulation of switched nonlinear systems and studied two types of stability problems, i.e., uniform stability under constrained switching and switching stabilization via designed state-dependent switching.

The results in Section 2.4 extend the work of [69] and [199] on stability analysis of switched linear systems to the general nonlinear setting. For a general class of nonautonomous switched nonlinear systems with both stable and unstable subsystems, sufficient conditions for uniform stability, uniform asymptotic stability, uniform exponential stability are derived via multiple Lyapunov functions. The results have also been verified through numerical simulations. It should be pointed out that the main results of Section 2.4 assume that the Lyapunov functions evolve in a single time-scale and there exists a global comparison (the ρ factor) among the multiple Lyapunov functions. Although this is a common assumption in the literature, it can be restrictive in some cases. Future work can be done to consider different time-scales of Lyapunov functions instead of a single time-scale and the situation when a global comparison among Lyapunov functions fails to exist. Difficulties in this direction can be expected in formulating the average dwell-time conditions and the balancing conditions on the activation time of stable and unstable modes.

In Section 2.5, we have investigated the problem of switching stabilization for a family of nonlinear systems. We propose two general rules to construct stabilizing switching signals, i.e., the minimal rule and the generalized rule. Not only have we shown that the resulting switched systems are globally uniformly asymptotically stable and globally uniformly exponentially stable, we have also rigorously proved that the switching signals generated by the generalized rule are well-defined in that the signals do not exhibit chattering and Zeno behavior. The stability analysis has been performed in terms of two measures so that the results can unify many different stability criteria, such as Lyapunov stability, partial stability, orbital stability, and stability of an invariant set. We have presented both numerical examples and simulations to illustrate the applications of the main results.

C H A 3 P T E R

Impulsive Switched Systems

As introduced in Chapter 1, systems of impulsive differential equations or impulsive dynamical systems model real world processes that undergo abrupt changes (impulses) in the state at discrete times. Particularly, impulse control and stabilization as a powerful tool to achieve stability for dynamical systems that can be highly unstable, in the absence of impulses, has gained increasing popularity and found successful applications in a wide variety of areas. Impulsive dynamical systems can be naturally viewed as a class of hybrid systems. Moreover, impulsive systems and switched systems can be naturally combined to form a more comprehensive model, i.e., impulsive switched systems.

In this chapter, we will present a general formulation for impulsive switched nonlinear systems and study two stability problems related to this hybrid system model. The general mathematical formulation for impulsive switched systems is given in Section 3.1. Particularly, Section 3.1.1 summarizes some important types of impulsive switching signals to be used in this thesis. In Section 3.2, we will extend the classical LaSalle's invariance principle to hybrid systems with impulses and switching. In Section 3.3, we will study the input-to-state stability of such systems.

3.1 Mathematical Formulation

To consider both impulse and switching in the same framework, we first introduce the notion of impulsive switching signals. Let \mathcal{I} and \mathcal{J} be two index sets. By an (time-dependent) *impulsive switching signal* associated with $(\mathcal{I}, \mathcal{J})$, we mean a sequence of

triples $\{(t_k, i_k, j_k) : k \in \mathcal{Z}^+\}$, where $i_k \in \mathcal{I}, j_k \in \mathcal{J}, t_k < t_{k+1}$ for all $k \in \mathcal{Z}^+$, and $t_k \rightarrow \infty$ as $k \rightarrow \infty$. The instants t_k are called the **impulsive switching times**.

An autonomous **impulsive switched system** is defined by a family of vector fields $\{f_i : i \in \mathcal{I}\}$, a family of impulse functions $\{I_j : j \in \mathcal{J}\}$, both f_i and I_j are defined from \mathcal{R}^n to \mathcal{R}^n , and an admissible set of impulsive switching signals \mathcal{S} . It can be written as

$$\begin{cases} x'(t) = f_{i_k}(x(t)), & t \in (t_k, t_{k+1}), & (3.1.1a) \\ \Delta x(t) = I_{j_k}(x(t^-)), & t = t_k, & (3.1.1b) \\ x(t_0) = x_0, & & (3.1.1c) \end{cases}$$

where $\{(t_k, i_k, j_k)\} \in \mathcal{S}$, $\Delta x(t) = x(t) - x(t^-)$, and $x(t^-)$ is the left limit of x at t . Roughly speaking, we can say that the impulsive switched system consists of a switched system given by (3.1.1a) and a family of difference equations given by (3.1.1b). More specifically, in (3.1.1), the impulsive switching signal $\{(t_k, i_k, j_k)\}$ imposes the following:

- A sequence of indices i_k to **switch** the right-hand side of (3.1.1a) among the family $\{f_i : i \in \mathcal{I}\}$;
- A sequence of indices j_k to select the **impulse** functions I_{j_k} from the family $\{I_j : j \in \mathcal{J}\}$ to reset the system state according to the difference equation (3.1.1b); and
- A sequence of discrete times t_k , called the **impulsive switching times** (except the initial time t_0^1), to determine when the switching and impulse occur.

We point out that this general formulation allows switching in the discrete dynamics as well. Therefore, both discrete- and continuous-time switched systems are covered by (3.1.1) in a certain sense.

It can be expected that, besides the family of functions $\{f_i : i \in \mathcal{I}\}$ and $\{I_j : j \in \mathcal{J}\}$, which govern the continuous dynamics and the discrete dynamics of system (3.1.1), respectively, it is expected that properties of solutions to system (3.1.1) (e.g., asymptotic stability and input-to-state stability properties to be investigated in this chapter) can also be significantly affected by the set \mathcal{S} of impulsive switching signal. Hence, it is of interest to characterize properties of solutions that are uniform over a certain class of impulsive switching signals. Also for this reason, one usually has to specify a certain class of signals in order to perform stability analysis for system (3.1.1). We will introduce different types

¹While a switching mode is assigned by i_0 at $t = t_0$, we do not consider a solution to instantly undergo an impulse at the initial time t_0 .

of impulsive switching signals in the next subsection. Particularly, weak dwell-time signals and generalized dwell-time signals will be used to investigate invariance and input-to-state properties, respectively, in Sections 3.2 and 3.3 of this chapter.

3.1.1 Classes of Generalized Impulsive Switching Signals

In Chapter 2, we have introduced the classes of dwell-time and average dwell-time switching signals, denoted by $\mathcal{S}(\tau)$ and $\mathcal{S}_a(\tau, N_0)$, respectively, as well as a particular class of switching signals ($\mathcal{S}(r, T)$) that balance stable and unstable modes of a given switched nonlinear system.

Now we formulate certain classes of impulsive switching signals. The convenience of doing this will become more evident as we progress in this thesis.

Generalized Dwell-Time Signals

We first introduce two classes of impulsive switching signals that generalize the well-known dwell-time conditions to dwell-time conditions with respect to specific switching modes.

Definition 3.1.1 (Dwell-Time) Given $\tau > 0$, we say that an impulsive switching signal $\sigma = \{(t_k, i_k, j_k)\}$ belongs to $\mathcal{S}_{\text{inf}}^i(\tau)$ or it has **dwell-time** τ in the i th mode, if it satisfies

$$\inf \{t_{k+1} - t_k : k \in \mathcal{Z}^+, i_k = i\} \geq \tau.$$

It is said to belong to $\mathcal{S}_{\text{sup}}^i(\tau)$ or have **reverse dwell-time** δ in the i th mode if

$$\sup \{t_{k+1} - t_k : k \in \mathcal{Z}^+, i_k = i\} \leq \tau.$$

In other words, an impulsive switching signal σ belongs to $\mathcal{S}_{\text{inf}}^i(\delta)$ or $\mathcal{S}_{\text{sup}}^i(\delta)$, if it assumes a dwell-time lower bound or dwell-time upper bound δ , respectively, with respect to the i th mode. For a fixed $\delta > 0$, the original dwell-time and reverse dwell-time signals (see, e.g., [69]) are recovered by

$$\mathcal{S}_{\text{inf}}(\delta) = \bigcap_{i \in \mathcal{I}} \mathcal{S}_{\text{inf}}^i(\delta), \quad \text{and} \quad \mathcal{S}_{\text{sup}}(\delta) = \bigcap_{i \in \mathcal{I}} \mathcal{S}_{\text{sup}}^i(\delta).$$

Generalized Average Dwell-Time Signals

If dwell-time is considered in the average sense, we have the following class of generalized average dwell-time signals.

Definition 3.1.2 (Average Dwell-Time) Given $\tau > 0$ and $N_0 > 0$, an impulsive switching $\sigma = \{(t_k, i_k, j_k)\}$ is said to belong to $\mathcal{S}_a^i(\tau, N_0)$ or have *average dwell-time* τ (and chatter bound N_0) in the i th mode, if

$$N_\sigma^i(T, t) \leq N_0 + \frac{|[t, T]_\sigma^i|}{\tau}, \quad \forall T \geq t \geq t_0,$$

where $N_\sigma^i(T, t)$ is the number of times the i th mode is activated by σ between t and T , and $[t, T]_\sigma^i$ is the union of all subintervals of $[t, T]$ on which the i th mode is activated and $|\cdot|$ denotes its total length. Therefore, $|[t, T]_\sigma^i|$ is the total activation time of the i th mode under the signal σ from t to T . Reversely, it is said to belong to $\mathcal{S}_{ra}^i(\tau, N_0)$ or have *reverse average dwell-time* τ in the i th mode if

$$N_\sigma^i(T, t) \geq \frac{|[t, T]_\sigma^i|}{\tau} - N_0, \quad \forall T \geq t \geq t_0.$$

Weak Dwell-Time Signals

The following notion of weak dwell-time generalizes the original dwell-time condition in the sense that a dwell-time condition is satisfied only in an asymptotic sense and only for a specific mode. We will use this notion to investigate invariance properties of impulsive switched systems in Section 3.2.

Definition 3.1.3 (Weak Dwell-Time) Given $\tau > 0$, an impulsive switching signal $\sigma = \{(t_k, i_k, j_k)\}$ is said to belong to $\mathcal{S}_{weak}^i(\tau)$ or have *weak dwell-time* τ in the i th mode, if one of the following equivalent statements holds:

- (i) for each $T \geq 0$, we can find a positive integer k such that $t_{k+1} - t_k \geq \tau$ with $t_k \geq T$ and $i_k = i$ (the i th mode is called a τ -*persistent mode* of the signal); or
- (ii) the union of all the intervals of the form $[t_k, t_{k+1})$ with length greater than τ and $i_k = i$, denoted by \mathcal{D}_i , has an infinite Lebesgue measure (we call \mathcal{D}_i a τ -*persistent domain* of the signal with respect to the i th mode). \square

The set of all signals with weak dwell-time τ can be written as

$$\mathcal{S}_{weak}(\tau) = \bigcup_{i \in \mathcal{I}} \mathcal{S}_{weak}^i(\tau).$$

Remark 3.1.1 Clearly, the above definitions only involves the sequence of pair $\{(t_k, i_k)\}$. Given an impulsive switching signal $\{(t_k, i_k, j_k)\}$, we can define

$$\sigma(t) = i_k, \quad t \in [t_k, t_{k+1}), \quad k \in \mathcal{Z}^+,$$

which defines a switching signal σ . Reversely, any switching signal σ has an equivalent sequence representation $\{(t_k, i_k)\}$ by letting $i_k = \sigma(t_k)$. Therefore, all the above definitions apply to switching signals as well. With this observation, we will again use σ to denote a given impulsive switching signal if the sequence $\{(t_k, i_k, j_k)\}$ itself is not explicitly considered. In the sequel, when we write $\sigma = \{(t_k, i_k, j_k)\}$, we have in mind both the impulsive switching signal $\{(t_k, i_k, j_k)\}$ as a whole and a switching signal σ constructed in the above sense. We find it convenient to make this overloading of notion, and make this remark to avoid possible confusion. \square

The roles of different classes of signals will become evident as they are applied to formulate different stability criteria and to establish invariance principles for hybrid systems later in this and subsequent chapters.

The rest of this chapter is organized as follows. In Section 3.2, we will establish a weak invariance principle for system (3.1.1) and apply this invariance principle to obtain two asymptotic stability criteria for system (3.1.1). An nonautonomous version of system (3.1.1) with external inputs will be formulated in Section 3.3, where the input-to-state properties of impulsive switched systems will be studied.

3.2 Invariance Principles

The classical LaSalle's invariance principle ([101], [102]) has been extended to hybrid and switched systems by various authors (see, e.g., [4], [35], [54], [69], [66], [136], [176]). In [69], under rather general switchings (including weak dwell-time switchings), an extension of LaSalle's principle is obtained for switched linear systems. In [4], a more traditional approach is taken and the results there cover general switched nonlinear systems, while a positive dwell-time condition is assumed. In [136], the results in [4] and [69] are extended and improved such that the results can deal with switched nonlinear systems with average dwell-time switching. Moreover, the weak invariance notion, which is essential to develop invariance principles for switched systems, is different from that of [4], and a more comprehensive property of the limit sets of a switched system is proved (Proposition 4.1 in [136]).

The work of [176] investigates asymptotic stability of switched linear systems with dwell-time switchings using invariance-like ideas, under additional ergodicity assumption on the switching signals. The work of [54] investigates invariance principles for switched systems, following a hybrid invariance principle derived for general hybrid systems on hybrid time domains [157]. Invariance-like principles for switched systems are also obtained in [66] by exploiting the norm-observability notions, under only a weak dwell-time condition on the switching signals. Moreover, the recent work of [104] proposed a generalized version of the celebrated Krasovskii-LaSalle theorem for general nonlinear and time-varying switched systems, with important implications in uniform asymptotic stability.

Despite the fact that there are various versions of invariance principles established in the literature for ordinary differential systems, similar invariance-like principles have not yet been well addressed for differential systems with impulse effects, which is in contrast with the fact that Lyapunov stability results on dynamical systems with impulse effects are extensively studied in the literature (e.g., [7], [99], [97], [117], [120], [156] and references therein). The only exception has been [35], in which the authors establish an invariance principle for dynamical systems with left-continuous flows, which applies to state-dependent impulsive systems as a special case. The authors of [35] point out, in the introduction, that there appear to be (at least) two difficulties to establish invariance-like principles for impulsive systems. Namely, solutions of impulsive dynamical systems are *not* continuous in time and are *not* continuous functions of the system's initial conditions, whereas these two continuity properties are essential to establish invariance principles for ordinary differential equations.

Inspired by the weak invariance principles established in [4] and [136] for switched systems using multiple Lyapunov functions, we note that, under the notion of weak invariance, those continuity properties may not be essential and, therefore, it becomes possible to establish weak invariance principles for impulsive switched systems, using a approach different from that of [35].

The main objective of this section is to present an extension of the classical LaSalle's invariance principle to impulsive switched hybrid systems like system (3.1.1) and derive asymptotic stability criteria of impulsive switched systems as important applications of this invariance principle. It is shown that the invariance principle developed here, by using a different approach from those of [35] and [54], improves various known results on switched systems in [4] and [136], while assuming only rather mild restriction on the switching signals. The results also cover impulsive differential systems as a special case.

In contrast with the work in [104], which studied time-varying switched systems, we focus on autonomous impulsive switched systems and explore invariance properties under this setting. The results also have important implications in asymptotic stability analysis.

The rest of this section is organized as follows. Section 3.2.1 gives the preliminary definitions and lemmas which are necessary to prove weak invariance principles for impulsive switched systems under weak dwell-time conditions. Section 3.2.2 is devoted to prove a weak invariance principle and Section 3.2.3 is on applying the weak invariance principles to asymptotic stability analysis. The main results are illustrated by several examples in Section 3.2.4. Comparisons with the previous results in the literature show that our results are less conservative and are applicable to a larger class of switched systems and impulsive systems. As an interesting application of the main results, we investigate a switched SEIR model with pulse treatment and establish global asymptotic stability of the disease-free solution under weak-dwell time signals in Section 3.2.5.

3.2.1 Preliminaries Results

We now formulate some preliminaries for developing invariance principles for impulsive switched systems.

Definition 3.2.1 A family of functions $\{V_i : i \in \mathcal{I}\}$ from \mathcal{R}^n to \mathcal{R} are called **multiple Lyapunov functions** for system (3.1.1) on a set $G \subset \mathcal{R}^n$ if

- (i) V_i is continuously differentiable at each point in G and is continuous on \bar{G} , the closure of G ;
- (ii) the derivative of each V_i along the i th mode of (3.1.1a) satisfies

$$\dot{V}_i(x) = \nabla V_i(x) \cdot f_i(x) \leq 0,$$

for all $x \in G$, where ∇ is the gradient. □

Although the idea of multiple Lyapunov functions has been introduced in Section 2.2, here we give a precise definition for use in this Section. Note that we do not require the Lyapunov functions to be positive definite to establish invariance principles. However, we do need positive definiteness to prove stability.

Definition 3.2.2 A family of functions $\{V_i : i \in \mathcal{I}\}$ from \mathcal{R}^n to \mathcal{R} is called **positive definite** on $G \subset \mathcal{R}^n$ if

(i) for each $i \in \mathcal{I}$, $V_i(x) \geq 0$ for all $x \in G$;

(ii) $V_i(x) = 0$ if and only if $x = 0$. □

Definition 3.2.3 A family of functions $\{V_i : i \in \mathcal{I}\}$ from \mathcal{R}^n to \mathcal{R} is called *radially unbounded* if $V_i(x) \rightarrow \infty$ as $|x| \rightarrow \infty$. □

The following assumption imposes a condition on the evolution of the functions V_i along a solution at the impulse and switching instants. This type of conditions are typically encountered in results involving multiple Lyapunov functions (see, e.g., [4], [20], [69], [66], [107], [136]).

Assumption 3.2.1 For every pair of impulse and switching instants $t_j < t_k$ of $\{(t_k, i_k, j_k)\}$ such that $i_j = i_k = i \in \mathcal{I}$, we have

$$V_i(x(t_k)) \leq V_i(x(t_{j+1})). \quad \square$$

Remark 3.2.1 In other words, Assumption 3.2.1 says that the value of $V_i(x(t))$ at the beginning of each interval $[t_k, t_{k+1})$ with $i_k = i$ does not exceed the value of V_i at the end of previous such interval (if one exists). Therefore, Assumption 3.2.1, together with the fact that $\{V_i\}$ is a family of multiple Lyapunov functions for (3.1.1), ensures that $V_i(x(t))$ is nonincreasing on the union of all the intervals where the i th mode of (3.1.1a) is activated. Therefore, a comparison of Assumption 3.2.1 with Assumption 2.4.1 in Section 2.4 shows that Assumption 3.2.1 implies Assumption 2.4.1 if $\{V_i\}$ is a family of multiple Lyapunov functions for (3.1.1) according to Definition 3.2.1. Therefore, following the argument in the proof for Theorem 2.4.1, we can prove Lyapunov stability of (3.1.1). □

Remark 3.2.2 Assumption 3.2.1 is trivially satisfied in the case when all the V_i are equal (common Lyapunov function) and there are no impulse effects. However, with the presence of impulse effects, Assumption 3.2.1 is *not* trivially satisfied for a common Lyapunov function V . Additional conditions have to be imposed, e.g., $V(x(t_k)) \leq V(x(t_k^-))$ at all switching instants t_k as in [35]. This kind of condition can be easily satisfied by impulse control, which, in the case of multiple Lyapunov functions, can also contribute to relax the conditions on V_i imposed by Assumption 3.2.1. □

We shall let $\mathcal{S}_{\text{weak}}(\tau)$ denote the set of impulsive switching signals with weak dwell-time τ , for some $\tau > 0$. Unless otherwise specified, let $\{(t_k, i_k, j_k)\}$ be a fixed signal in $\mathcal{S}_{\text{weak}}(\tau)$

and x be the corresponding solution to (3.1.1) with $\{(t_k, i_k, j_k)\}$. Let $i \in \mathcal{I}$ be a persistent mode of the signal. Without confusion, we may also say that i is a persistent mode of x .

Definition 3.2.4 Given $i \in \mathcal{I}$, a point $\eta \in \mathcal{R}^n$ is said to be a **persistent limit point** of x in the i th mode, if i is a persistent mode and there exists a sequence of $s_n \in \mathcal{D}_i$, with $s_n \rightarrow \infty$ as $n \rightarrow \infty$, such that $x(s_n) \rightarrow \eta$ as $n \rightarrow \infty$. The set of all such points is called the **persistent limit set** of x in the i th mode and is denoted by $\omega_i(x)$. \square

Definition 3.2.5 A set $M \subset \mathcal{R}^n$ is called a **weakly invariant set** with respect to the i th mode of (3.1.1a), if, for any $\xi \in M$, there exist a positive number r and a continuously differentiable function ϕ defined on some interval $[\alpha, \beta]$, with $\alpha \leq 0 \leq \beta$ and $\beta - \alpha \geq r$, such that

$$(i) \quad \phi'(t) = f_i(\phi(t)), \forall t \in [\alpha, \beta],$$

$$(ii) \quad \phi(0) = \xi,$$

$$(iii) \quad \phi(t) \in M, \forall t \in [\alpha, \beta]. \quad \square$$

Definition 3.2.6 The solution x is said to **weakly approach** a set $M \subset \mathcal{R}^n$ in the i th mode as $t \rightarrow \infty$, if the i th mode persists and

$$\lim_{\substack{t \rightarrow \infty \\ t \in \mathcal{D}_i}} \text{dist}(x(t), M) = 0,$$

where $\text{dist}(y, M)$ for $y \in \mathcal{R}^n$ is defined by

$$\text{dist}(y, M) = \inf_{z \in M} |y - z|.$$

Remark 3.2.3 The convergence in Definition 3.2.6 is called “weak approaching” because the limit is only taken for $t \in \mathcal{D}_i$, not the entire real line. \square

Lemma 3.2.1 *If x is bounded and $i \in \mathcal{I}$ denotes a persistent mode of x , then the persistent limit set $\omega_i(x)$ is a nonempty, compact, and weakly invariant set with respect to the i th mode of (3.1.1a). Moreover, $x(t)$ weakly approaches $\omega_i(x)$ in the i th mode as $t \rightarrow \infty$.*

Proof. Since the persistent domain \mathcal{D}_i has an infinite Lebesgue measure, one can pick up a sequence $\{s_n\}$ in \mathcal{D}_i such that $s_n \rightarrow \infty$ as $n \rightarrow \infty$. Since $x(t)$ is bounded on $[0, \infty)$, it follows that $\{x(s_n)\}$ is a bounded sequence and therefore has a subsequence which converges

to some limit point i . By definition, i is a persistent limit point in the i th mode, which shows $\omega_i(x)$ is nonempty.

Since $x(t)$ is bounded, it follows that $\omega_i(x)$ is bounded. To show closedness of $\omega_i(x)$, suppose $\xi_n \in \omega_i(x)$ approaches ξ as $n \rightarrow \infty$. Since $\xi_n \in \omega_i(x)$ for each n , by Definition 3.2.4, one can choose $s_n \in \mathcal{D}_i$, for each n , large enough such that $|x(s_n) - \xi_n| < 1/n$. Now given any $\varepsilon > 0$, choose n large enough so that $|\xi_n - \xi| < \varepsilon/2$ and $|x(s_n) - \xi_n| < \varepsilon/2$. Then $|x(s_n) - \xi| < \varepsilon$ for n large enough, which shows $\xi \in \omega_i(x)$ and therefore $\omega_i(x)$ is closed. It follows that $\omega_i(x)$ is compact.

The last assertion of the lemma can be shown by contradiction. Suppose that there exists an increasing sequence of s_n in \mathcal{D}_i , with $s_n \rightarrow \infty$ as $n \rightarrow \infty$, and a $\delta > 0$ such that $|x(s_n) - \xi| \geq \delta$ for all $\xi \in \omega_i(x)$. Now since $x(s_n)$ is a bounded sequence, there exists a subsequence of $x(s_n)$ which converges to some $\xi \in \omega_i(x)$. This contradicts with the inequality above and shows that the last assertion of the lemma holds.

Finally, we show that $\omega_i(x)$ is weakly invariant with respect to the i th mode of (3.1.1), i.e., for any ξ in $\omega_i(x)$, there exist a positive number r and a continuously differentiable function ϕ defined on some interval $[\alpha, \beta]$, with $\alpha \leq 0 \leq \beta$ and $\beta - \alpha \geq r$, such that (i) $\phi'(t) = f_i(\phi(t))$, $\forall t \in [\alpha, \beta]$, (ii) $\phi(0) = \xi$, and (iii) $\phi(t) \in \omega_i(x)$, $\forall t \in [\alpha, \beta]$.

Since $\xi \in \omega_i(x)$, there exists an increasing sequence of $s_n \in \mathcal{D}_i$ such that $s_n \rightarrow \infty$ and $x(s_n) \rightarrow \xi$ as $n \rightarrow \infty$. Moreover, we can pick s_n so that there exists a sequence of intervals $[\tau_{2n-1}, \tau_{2n}]$ which satisfies that, for all n ,

- (i) $\tau_{2n} - \tau_{2n-1} \geq \tau$,
- (ii) $s_n \in [\tau_{2n-1}, \tau_{2n}]$,
- (iii) the i th mode is activated on $[\tau_{2n-1}, \tau_{2n}]$.

By this choice, $x(t)$ satisfies the i th subsystem on $[\tau_{2n-1}, \tau_{2n}]$ for all n , i.e., $x'(t) = f_i(x(t))$, $\forall t \in [\tau_{2n-1}, \tau_{2n}]$. Moreover, we have that $x(t)$ is continuously differentiable on (τ_{2n-1}, τ_{2n}) . Putting

$$\alpha_n = \tau_{2n-1} - s_n \quad \text{and} \quad \beta_n = \tau_{2n} - s_n, \quad (3.2.1)$$

then $\beta_n - \alpha_n \geq \tau$ and $\alpha_n \leq 0 \leq \beta_n$. Define

$$\phi_n(t) := x(t + s_n), \quad t \in [\alpha_n, \beta_n]. \quad (3.2.2)$$

It follows that ϕ_n satisfies

$$\phi_n'(t) = f_i(\phi_n(t)), \quad t \in [\alpha_n, \beta_n], \quad (3.2.3)$$

$\phi_n(0) = x(s_n) \rightarrow \xi$ as $n \rightarrow \infty$, and ϕ_n is continuously differentiable on (α_n, β_n) .

We claim that the sequence of intervals $[\alpha_n, \beta_n]$ has a subsequence, still designated by $[\alpha_n, \beta_n]$, which has a common subinterval $[\alpha, \beta]$, i.e., $[\alpha, \beta] \subset [\alpha_n, \beta_n]$ for all n , with $\beta - \alpha \geq \tau/2$ and $\alpha \leq 0 \leq \beta$. Actually, it is clear that either $\{\alpha_n\}$ has a subsequence, for which we can keep the same designation, that lies in $(-\infty, -\tau/2]$ or it has a subsequence in $[-\tau/2, 0]$. In the latter case, since $\beta_n - \alpha_n \geq \tau$, one must have $\beta_n \geq \tau/2$ and therefore letting $\alpha = 0$, $\beta = \tau/2$ will give the required common subinterval; in the former case, since $\beta_n \geq 0$, letting $\alpha = -\tau/2$, $\beta = 0$ gives the required common subinterval. Now according to (3.2.2) and (3.2.3), what we have obtained is a sequence of functions ϕ_n defined on a common interval $[\alpha, \beta]$, with $\beta - \alpha \geq \tau/2$ and $\alpha \leq 0 \leq \beta$, such that

$$\phi_n'(t) = f_i(\phi_n(t)), \quad t \in [\alpha, \beta]. \quad (3.2.4)$$

We proceed to show that ϕ_n has a subsequence that converges uniformly to a function ϕ on $[\alpha, \beta]$. Since $x(t)$ is bounded, it follows that ϕ_n is uniformly bounded on $[\alpha, \beta]$. Since f_i is continuous, it follows that $\phi_n'(t) = f_i(\phi_n(t))$ is uniformly bounded on $[\alpha, \beta]$. By the mean-value theorem, this implies that the sequence ϕ_n is equicontinuous on $[\alpha, \beta]$. By the Arzela-Ascoli Theorem, there exists a subsequence of ϕ_n , still designated by ϕ_n , which uniformly converges to some function ϕ on $[\alpha, \beta]$ and ϕ is continuously differentiable on (α, β) . Passing the limit in (3.2.4) (or its equivalent integral form), one is able to see that ϕ satisfies $\phi'(t) = f_i(\phi(t))$, $t \in [\alpha, \beta]$. Moreover, $\phi(0) = \lim_{n \rightarrow \infty} \phi_n(0) = \xi$. Finally, we have $\phi(t) = \lim_{n \rightarrow \infty} \phi_n(t) = \lim_{n \rightarrow \infty} x(t + s_n)$ for any fixed $t \in [\alpha, \beta]$. For a fixed $t \in [\alpha, \beta]$, put $s'_n = t + s_n$. According to (3.2.1), $s'_n \in [\tau_{2n-1}, \tau_{2n}]$ for each n . Since the i th mode is activated on $[\tau_{2n-1}, \tau_{2n}]$ and $\tau_{2n} - \tau_{2n-1} \geq \tau$, by Definition 3.2.4, it follows that $\phi(t) \in \omega_i(x)$ for all $t \in [\alpha, \beta]$ as required. Therefore $\omega_i(x)$ is shown to be weakly invariant with respect to the i th mode of (3.1.1) and the proof is complete. \square

3.2.2 A Weak Invariance Principle

Let $\{V_i : i \in \mathcal{I}\}$ be a family of multiple Lyapunov functions for (3.1.1) on $G \subset \mathcal{R}^n$ and define

$$E_i := \{x \in \bar{G} : \dot{V}_i(x) = 0\}.$$

Let M_i denote the largest weakly invariant set with respect to the i th mode of (3.1.1) in E_i .

Theorem 3.2.1 *Let $\{V_i : i \in \mathcal{I}\}$ be a family of multiple Lyapunov functions for (3.1.1) on G , x be a bounded solution of (3.1.1) such that $x(t)$ remains in G for $t \geq 0$, and $i \in \mathcal{I}$ be a persistent*

mode of x . Suppose, in addition, Assumption 3.2.1 is satisfied. Then x weakly approaches $M_i \cap V_i^{-1}(c)$, for some c , in the i th mode as $t \rightarrow \infty$.

Proof. By Lemma 3.2.1, x has a nonempty persistent limit set in the i th mode $\omega_i(x)$. We proceed to show that $\omega_i(x) \subset E_i$. Let \mathcal{D}_i denote the union of all the intervals of length greater than τ such that the i th mode is active. Since the i th mode persists, \mathcal{D}_i must have an infinite Lebesgue measure. The conditions on V_i imply that $V_i(x(t))$ is nonincreasing on \mathcal{D}_i . Moreover, $V_i(x(t))$ is bounded below since $x(t)$ is bounded. Therefore, as $t \rightarrow \infty$ in \mathcal{D}_i , $V_i(x(t))$ yields a limit as

$$\lim_{\substack{t \rightarrow \infty \\ t \in \mathcal{D}_i}} V_i(x(t)) = c.$$

For any $\xi \in \omega_i(x)$, there exists a sequence $s_n \in \mathcal{D}_i$ such that $s_n \rightarrow \infty$ and $x(s_n) \rightarrow \xi$ as $n \rightarrow \infty$. It follows by the continuity of V_i that

$$V_i(\xi) = \lim_{n \rightarrow \infty} V_i(x(s_n)) = \lim_{\substack{t \rightarrow \infty \\ t \in \mathcal{D}_i}} V_i(x(t)) = c.$$

Hence, $V_i(\xi) = c$ for all $\xi \in \omega_i(x)$ and $\omega_i(x) \subset V_i^{-1}(c)$. According to Lemma 3.2.1, $\omega_i(x)$ is weakly invariant with respect to the i th mode, that is, for each $\xi \in \omega_i(x)$, there exist a positive number r and a continuous differentiable function ϕ defined on some interval $[\alpha, \beta]$, with $\alpha \leq 0 \leq \beta$ and $\beta - \alpha \geq r$, such that (i) $\phi'(t) = f_i(\phi(t))$, $\forall t \in [\alpha, \beta]$, (ii) $\phi_0 = \xi$, (iii) $\phi(t) \in \omega_i(x)$, $\forall t \in [\alpha, \beta]$. Hence, $V_i(\phi(t)) = c$ for all $t \in [\alpha, \beta]$. Differentiating $V_i(\phi(t))$ at $t = 0$ gives

$$\dot{V}_i(\xi) = \nabla V_i(\xi) \cdot f_i(\xi) = 0.$$

It follows that $\omega_i(x) \subset E_i$. By the definition of M_i and because $\omega_i(x)$ is weakly invariant with respect to the i th mode of (3.1.1a), we have $\omega_i(x) \subset M_i \subset E_i$. From Lemma 3.2.1, x weakly approaches $\omega_i(x)$ in the i th mode and therefore it weakly approaches $M_i \cap V_i^{-1}(c)$ in the i th mode. This completes the proof. \square

3.2.3 Stability Criteria

We now apply the invariance principle established in Section 3.2.2 to derive some results on asymptotic stability for impulsive switched systems under weak dwell-time conditions. Let $\mathcal{S}_{\text{weak}}^i(\tau)$ denote the set of impulsive and switching signals with weak dwell-time τ and $i \in \mathcal{I}$ as a persistent mode. We use B_r to denote the ball $\{x \in \mathcal{R}^n : |x| \leq r\}$ for any $r > 0$.

If we assume $f_i(0) = 0$ for all $i \in \mathcal{I}$ and $I_j(0) = 0$ for all $j \in \mathcal{J}$, then (3.1.1) have a trivial solution. Let \mathcal{S} be a certain set of impulsive and switching signals.

Definition 3.2.7 The trivial solution of (3.1.1) is said to be

- (\mathcal{S}_1) **stable** with respect to \mathcal{S} if, for each $\varepsilon > 0$, there exists a $\delta > 0$ such that, for each solution $x(t)$ starting from x_0 with $\{(t_k, i_k, j_k)\} \in \mathcal{S}$, $|x_0| < \delta$ implies that $|x(t)| < \varepsilon$ for all $t \geq 0$;
- (\mathcal{S}_2) **asymptotically stable** with respect to \mathcal{S} if (\mathcal{S}_1) is satisfied and there exists some $\rho > 0$ such that $|x_0| < \rho$ implies that $\lim_{t \rightarrow \infty} x(t) = 0$;
- (\mathcal{S}_3) **globally asymptotically stable** with respect to \mathcal{S} if (\mathcal{S}_2) is satisfied with arbitrary $\rho > 0$;
- (\mathcal{S}_4) **unstable** with respect to \mathcal{S} if (\mathcal{S}_1) fails. □

Theorem 3.2.2 Suppose that \mathcal{I} is a finite set and there exist a family of positive definite multiple Lyapunov functions $\{V_i : i \in \mathcal{I}\}$ for (3.1.1) on B_ρ for some $\rho > 0$. Suppose, in addition, Assumption 3.2.1 is satisfied. Then the trivial solution of (3.1.1) is asymptotically stable w.r.t $\mathcal{S}_{weak}^i(\tau)$, provided that $M_i = \{0\}$. If $\bigcup_{i \in \mathcal{I}} M_i = \{0\}$, then the trivial solution of (3.1.1) is asymptotically stable w.r.t $\mathcal{S}_{weak}(\tau)$.

Proof. Lyapunov stability follows from Assumption 3.2.1 and Remark 3.2.1. Given any $\varepsilon_0 \in (0, \rho)$, let $\delta(\varepsilon_0)$ be the local stability constant such that $x_0 \in B_{\delta(\varepsilon_0)}$ implies $x(t) \in B_{\varepsilon_0} \subset B_\rho$ for all $t \geq 0$. We claim that $B_{\delta(\varepsilon_0)}$ is a domain of attraction for (3.1.1). Actually, $x(t) \in B_{\varepsilon_0}$ for all $t \geq 0$, x is clearly a bounded solution. According to Theorem 3.2.1, any solution starting from $B_{\delta(\varepsilon_0)}$ weakly approaches $M_i = \{0\}$ in the i th mode as $t \rightarrow \infty$. Now for any $\varepsilon \in (0, \varepsilon_0)$, let $\delta(\varepsilon) > 0$ be the local stability constant such that $x_0 \in B_{\delta(\varepsilon)}$ implies $x(t) \in B_\varepsilon$ for all $t \geq 0$. Let x be an arbitrary solution starting from $B_{\delta(\varepsilon_0)}$. Since x weakly approaches $M_i = \{0\}$ in the i th mode as $t \rightarrow \infty$, we can find T large enough in \mathcal{D}_i so that $|x(T)| \leq \delta$, for any $\delta = \delta(\varepsilon) > 0$. By how we have chosen $\delta(\varepsilon)$, it follows that $|x(t)| < \varepsilon$ for all $t \geq T$. Because ε can be arbitrarily chosen, this shows $x(t) \rightarrow 0$ as $t \rightarrow \infty$ and asymptotic stability follows. □

Theorem 3.2.3 Suppose that \mathcal{I} is a finite set. Let $\{V_i : i \in \mathcal{I}\}$ be a family of positive definite and radially unbounded multiple Lyapunov functions for (3.1.1) on \mathcal{R}^n . Suppose, in addition,

Assumption 3.2.1 is satisfied. Then the trivial solution of (3.1.1) is globally asymptotically stable with respect to $\mathcal{S}_{weak}^i(\tau)$, provided that $M_i = \{0\}$. If $\bigcup_{i \in \mathcal{I}} M_i = \{0\}$, then the trivial solution of (3.1.1) is globally asymptotically stable with respect to $\mathcal{S}_{weak}(\tau)$.

Proof. Lyapunov stability remains the same. To show global attraction, we only have to show that the constant $\delta(\varepsilon_0)$ in the proof for Theorem 3.2.2 can be chosen to be arbitrarily large, provided that ε_0 is given sufficiently large. Now given any $\varepsilon_0 > 0$, we let $\delta_0 = \varepsilon_0$ and define $\delta_1, \delta_2, \dots, \delta_N$ recursively such that $v(\delta_{j+1}) = u(\delta_j/2)$ for $j = 0, 1, 2, \dots, N-1$, where N is the cardinality of \mathcal{I} . Since $u(\delta_j/2) < u(\delta_j)$, it is clear that this choice of $\delta_1, \delta_2, \dots, \delta_N$ is in accordance with that in the proof of local stability in Theorem 3.2.2. Moreover, as $\varepsilon_0 \rightarrow \infty$, so does $\delta_1, \delta_2, \dots$, and δ_N . Therefore $\delta(\varepsilon_0) = \delta_N(\varepsilon_0)$ can be arbitrarily large if ε_0 is given sufficiently large. This completes the proof. \square

Remark 3.2.4 Specialized to the switched system framework, two main features that make our results improve those in [4] and [136] are as follows. First, the notion of persistent limit set is introduced here, and it is therefore not required that the solution converges to its limit set (only weakly approaching is required). This weakly approaching notion together with local stability (guaranteed by the existence of multiple Lyapunov functions) actually suffices to guarantee asymptotic stability as shown in Theorem 3.2.2. Second, the largest invariant set M_i in each E_i is explicitly defined with respect to the i th mode, which makes the set $\bigcup_{i \in \mathcal{I}} M_i$ smaller (and in many cases remarkably smaller, as shown by several examples in Section 3.2.4) than the set M in [4], which is defined as the largest weakly invariant set (with respect to whatever mode) in the set $\bigcup_{i \in \mathcal{I}} E_i$ (according to our notation). This difference makes our results less conservative. Particularly, Theorem 3.2.2, specialized to switched systems without impulses, improves both Theorem 1 (in the case where a common Lyapunov function exists) and Theorem 2 of [4], the main results presented there, not only in that the dwell-time conditions are now replaced by weak dwell-time conditions, but also, more importantly, in that the set M is now remarkably smaller and, therefore, more precise convergence results can be obtained. \square

Remark 3.2.5 Even though $\bigcup_{i \in \mathcal{I}} M_i$ obtained in Theorem 3.2.2 and Theorem 3.2.3 can be remarkably smaller than the set M defined in [4], we may not yet, in some cases, be able to conclude that $\bigcup_{i \in \mathcal{I}} M_i = \{0\}$. However, if we know that the i th mode of a switching signal persists and $M_i = \{0\}$, for some $i \in \mathcal{I}$, then we are still able to show that the solution

converges to zero from Theorem 3.2.2 and Theorem 3.2.3, while none of the results in [4], [69], [66], and [136] can give any useful information. \square

Theorem 2.3 of [136] gives an interesting stability criterion for switched systems, based on a zero-state small-time observability hypothesis, which partially generalizes Theorem 7 of [66] in that the zero-state small-time observability hypothesis is weaker than the small-time norm-observability assumption in [66]. However, Theorem 2.3 of [136] requires an average dwell-time condition, while Theorem 7 of [66] applies to weak dwell-time switchings. Now we apply our Theorem 3.2.2 to show the following stability criterion for impulsive switched systems, which is also based on a zero-state small-time observability hypothesis and generalizes both results from [66] and [136].

Corollary 3.2.1 *Suppose that \mathcal{I} is a finite set. Let $\{V_i : i \in \mathcal{I}\}$ be a family of positive definite and radially unbounded functions and $\{W_i : i \in \mathcal{I}\}$ a family of nonnegative functions on \mathcal{R}^n . Suppose that*

$$(i) \quad V_i'(x) \leq -W_i(x), \text{ for all } x \in \mathcal{X}_i; \text{ and}$$

(ii) *there exists some $i \in \mathcal{I}$ such that the system*

$$x' = f_i(x), \quad y = W_i(x), \tag{3.2.5}$$

is zero-state small-time observable².

Suppose, in addition, Assumption 3.2.1 is satisfied. Then the trivial solution of (3.1.1) is globally asymptotically stable with respect to $\mathcal{S}_{weak}^i(\tau)$. If system (3.2.5) is zero-state small-time observable for all $i \in \mathcal{I}$, then the trivial solution of (3.1.1) is globally asymptotically stable with respect to $\mathcal{S}_{weak}(\tau)$.

Proof. It is easy to see that $\{V_i : i \in \mathcal{I}\}$ is a family of positive definite and radially unbounded functions for (3.1.1) on \mathcal{R}^n . According to Theorem 3.2.2, we only have to show $M_i = \{0\}$. Choose any $\xi \in M_i$. By definition, there exist a positive number r and a continuously differentiable function ϕ defined on some interval $[\alpha, \beta]$, with $\alpha \leq 0 \leq \beta$ and $\beta - \alpha \geq r$, such that: (i) $\phi'(t) = f_i(\phi(t))$, $\forall t \in [\alpha, \beta]$, (ii) $\phi(0) = \xi$, (iii) $\phi(t) \in M_i$,

²According to the definition in [136], a system such as (3.2.5) is said to be zero-state small-time observable, if for every $\delta > 0$, we have $x(0) = 0$ whenever $W_i(x(t)) = 0$ for all $t \in [0, \delta]$.

$\forall t \in [\alpha, \beta]$. By condition (i), we have $M_i \subset E_i \subset \{x \in \mathcal{R}^n : W_i(x) = 0\}$. Hence $W_i(\phi(t)) = 0$ for all $t \in [\alpha, \beta]$. If $\beta > 0$, then the zero-state small-time observability condition on (f_i, W_i) implies that $\phi(0) = \xi = 0$. If $\beta = 0$, we claim that $\phi(t) = 0$ for all $t \in [\alpha, 0)$. Therefore, we still have $\phi(0) = \xi = 0$ by continuity of ϕ . To show the claim, choose any $s_0 \in [\alpha, 0)$. Define $\psi(s) = \phi(s + s_0)$ for $s \in [0, -s_0)$. Then $\psi(s)$ satisfies $\psi'(s) = f_i(\psi(s))$ and $W_i(\psi(s)) = 0$ on $[0, -s_0)$. By the zero-state small-time observability condition, we have $\psi(0) = \phi(s_0) = 0$. Since s_0 is arbitrarily chosen from $[\alpha, 0)$, we have the claim proved and it follows that $\phi(0) = \xi = 0$. We have shown $M_i = \{0\}$. The conclusions of the corollary follow from Theorem 3.2.2. \square

Remark 3.2.6 Corollary 3.2.1, specialized to switched systems, is more general than Theorem 2.3 in [136], since it only requires a weak dwell-time condition and applies to the situation where only one of the pairs (f_i, W_i) satisfies a zero-state small-time observability condition. It is also more general than Theorem 7 from [66] in that the zero-state small-time observability condition is weaker than the small-time norm-observability assumption in [66], as shown by an example in [136]. \square

3.2.4 Examples

In this section, we apply the main results to several examples. Unless otherwise specified, the set G in the definition of E_i in Section 3.2.2 is taken to be \mathcal{R}^n . We first present comparisons of our main results obtained in this section and those in [4], [69], [66], and [136].

Example 3.2.1 [4, Example 4] Consider two subsystems given by

$$x' = f_1(x) = \begin{Bmatrix} -x_1 - x_2 \\ x_1 \end{Bmatrix},$$

and

$$x' = f_2(x) = \begin{Bmatrix} -x_1 \\ -x_2 \end{Bmatrix}.$$

Let $V_1 = V_2 = \frac{1}{2}|x|^2$. Then $E_1 \subset \{x_1 = 0\}$ and $E_2 = \{0\}$. It is easy to see that $M_1 = M_2 = \{0\}$. By Theorem 3.2.2, the trivial solution of the switched system is globally asymptotically stable with respect to $\mathcal{S}_{\text{weak}}(\tau)$ for any $\tau > 0$, whereas in [4] it can only be concluded, by Theorem 1 there, that all the solutions tend to the x_2 axis, even under dwell-time switching. \square

Example 3.2.2 [136, Example 2] Consider two subsystems given by

$$x' = f_1(x) = \begin{Bmatrix} -x_1 - x_2 \\ x_1 \end{Bmatrix},$$

and

$$x' = f_2(x) = -\frac{1}{1 + |x|^4} \begin{Bmatrix} x_1 \\ x_2 \end{Bmatrix}.$$

The example is essentially similar to Example 3.2.1. By considering the common Lyapunov function $V_1 = V_2 = |x|^2$ and applying the same argument as in Example 3.2.1, it can be shown that the trivial solution of the resulting switched system is globally asymptotically stable with respect to $\mathcal{S}_{\text{weak}}(\tau)$ for any $\tau > 0$, while in [136] the asymptotic stability can only be concluded under average dwell-time switchings. \square

Example 3.2.3 Consider two subsystems given by

$$x' = f_1(x) = \begin{Bmatrix} -x_2 \\ x_1 - 2x_2^k \end{Bmatrix},$$

and

$$x' = f_2(x) = \begin{Bmatrix} x_2 \\ -x_1 - 2x_2^k \end{Bmatrix},$$

where $k \geq 1$ is any odd integer. For $k = 1$, f_1 and f_2 are linear vector fields. It is shown in [69, Example 2] that the resulting switched system is asymptotically stable under weak dwell-time switchings. On the other hand, it is also shown that there exists a switching signal, which is not of weak dwell-time, such that the trajectory does not converge to zero. Now as a general case when $k \geq 1$, we can construct a common Lyapunov function $V_1 = V_2 = |x|^2$. Then $E_1 = E_2 = \{x_2 = 0\}$. It is easy to see that $M_1 = M_2 = \{0\}$. By Theorem 3.2.2, the trivial solution of the resulting switched system is globally asymptotically stable with respect to $\mathcal{S}_{\text{weak}}(\tau)$ for any $\tau > 0$. This example can be seen as a complement to the results in [69], as for now nonlinear vector fields are allowed and the same conclusion holds, i.e., global asymptotic stability of the resulting switched system under weak dwell-time switchings. \square

Example 3.2.4 [4, Example 2] Consider two subsystems given by

$$x' = f_1(x) = \begin{Bmatrix} -x_2 \\ x_1 - x_2^k \end{Bmatrix},$$

and

$$x' = f_2(x) = \begin{Bmatrix} x_2 \\ -x_1 - x_2^k \end{Bmatrix},$$

where $k \geq 1$ is any odd integer. This example is essentially similar to the previous one. By defining a common Lyapunov function $V_1 = V_2 = |x|^2$, Theorem 3.2.2 shows that the trivial solution of the resulting switched system is globally asymptotically stable with respect to $\mathcal{S}_{\text{weak}}(\tau)$ for any $\tau > 0$, while in [4] similar results were obtained only for dwell-time switchings. \square

Remark 3.2.7 It can be shown that, for Examples 3.2.3 and 3.2.4, there exists no common strict Lyapunov functions. Otherwise, the sum of the two right-hand sides would define an asymptotically stable system, which is not the case for both examples. \square

Example 3.2.5 [4, Example 5] Consider two subsystems given by

$$x' = f_1(x) = \begin{Bmatrix} -x_1 - x_2 \\ x_1 \end{Bmatrix},$$

and

$$x' = f_2(x) = \begin{cases} \begin{Bmatrix} -x_1 - x_2 \\ x_1 \end{Bmatrix}, & x_1 < 0, \\ \begin{Bmatrix} -x_2 \\ x_1 \end{Bmatrix}, & x_2 \geq 0, \end{cases}$$

where the second system appears to be with discontinuous right-hand side but indeed defines a continuous differential system. In [4], it is pointed out that if one uses the common Lyapunov function $V_1 = V_2 = |x|^2$, no useful information can be obtained by their results, since $Z = \{x_1 \geq 0\}$ itself becomes a weakly invariant set (by their notation). However, according to our results, we have $E_1 \subset \{x_1 = 0\}$ and $E_2 \subset \{x_1 \geq 0\}$. It follows that $M_1 = \{0\}$ and $M_2 = \{x_1 \geq 0\}$. Although $M_1 \cup M_2 \neq \{0\}$, we do have $M_1 = \{0\}$. We may still apply our Theorem 3.2.2. Since $f_1(x) = f_2(x)$ when $x_1 < 0$, an arbitrary switching can be equivalently modified so that the first mode is activated on $\{x_1 < 0\}$. If the first mode is activated on $\{x_1 < 0\}$, it follows that the first mode is a persistent mode of the signal (it actually takes at least a constant time for the system to travel out $\{x_1 < 0\}$). Now according to Theorem 3.2.2,

the trivial solution of the resulting switched system is globally asymptotically stable with respect to $\mathcal{S}_{\text{weak}}^1(\tau)$ for any $\tau > 0$. By the fact that an arbitrary switching has an equivalent modification in $\mathcal{S}_{\text{weak}}^1(\tau)$, we actually obtain that the origin is globally asymptotically stable under arbitrary switching, which agrees with the results shown in [18] by the method of “worst case” argument (see also [40]). \square

Remark 3.2.8 Example 3.2.1 and Example 3.2.5 are originally presented in [4] to show the limitations of their results. As we can see from these examples, our invariance principles and stability theorems presented in this section can effectively overcome these limitations and are applicable to an even larger class of switched systems. Example 3.2.5 also shows that our stability criteria can also be applied to switched systems with state-dependent switchings. \square

Example 3.2.6 Consider a family of Liénard’s equations

$$y'' + h_i(y)y' + g_i(y) = 0, \quad i \in \mathcal{I}.$$

Let $x_1 = y$, $x_2 = y'$. Then an equivalent family of systems is

$$x' = f_i(x) = \left\{ \begin{array}{c} x_2 \\ -g_i(x_1) - h_i(x_1)x_2 \end{array} \right\}, \quad i \in \mathcal{I}.$$

Let $\mathcal{K}_i, i \in \mathcal{I}$, be a covering of \mathcal{R}^2 that defines the state-dependent switchings for a switched system given by the above family of Liénard’s equations, i.e., the i th mode can be activated only if $x(t) \in \mathcal{K}_i$. Let \mathcal{K}_i^1 denote the projection of \mathcal{K}_i into its first component. Assume that, for all $i \in \mathcal{I}$,

- (i) $G_i(x) = \int_0^x g_i(\xi)d\xi > 0$ for all $x \in \mathcal{K}_i^1$ such that $x \neq 0$,
- (ii) $G_i(x) \rightarrow \infty$, as $x \in \mathcal{K}_i^1$ such that $|x| \rightarrow \infty$,
- (iii) $g_i(x) \neq 0$, for all $x \in \mathcal{K}_i^1$ such that $x \neq 0$,
- (iv) $h_i(x) > 0$, for all $x \in \mathcal{K}_i^1$ such that $x \neq 0$.

We take the Lyapunov function candidates to be the total energy of each subsystem

$$V_i(x) = G_i(x_1) + \frac{x_2^2}{2}. \quad (3.2.6)$$

Then

$$V_i'(x) = -h_i(x_1)x_2^2 \leq 0. \quad (3.2.7)$$

Hence, by the assumptions above, we can see that V_i defines a family of positive definite and radially unbounded multiple Lyapunov functions for the switched system. According to (3.2.7), we have $E_i \subset \{x_1 = 0\} \cup \{x_2 = 0\}$. Now it is easy to check that $M_i = \{0\}$ for all $i \in \mathcal{I}$ by the assumptions above. Therefore, we can conclude, by Theorem 3.2.2, that the trivial solution of the resulting switched system is globally asymptotically stable with respect to $\mathcal{S}_{\text{weak}}(\tau)$ for any $\tau > 0$, provided that Assumption 3.2.1 is satisfied. The assumptions (iii) and (iv) on g_i and h_i can be replaced by the following weaker ones, for some particular $i \in \mathcal{I}$,

(iii') $g_i(x) \neq 0$, for all $x \in \mathcal{K}_i^1$ such that $x \neq 0$,

(iv') $h_i(x) > 0$, for all $x \in \mathcal{K}_i^1$ such that $x \neq 0$,

and

(iv'') $h_i(x) \geq 0$, for all $x \in \mathcal{K}_i^1$ such that $x \neq 0$, for all $i \in \mathcal{I}$.

Now, by the same argument, we are only able to conclude that $M_i = \{0\}$ for this particular i . Nevertheless, Theorem 3.2.2 guarantees that the trivial solution of the resulting switched system is globally asymptotically stable with respect to $\mathcal{S}_{\text{weak}}^i(\tau)$ for any $\tau > 0$, provided that Assumption 3.2.1 is satisfied. It is worth noting that none of the results in [4], [69], [66], and [136] can give any useful information in this case. \square

Example 3.2.7 Revisit Example 3.2.6 by introducing an impulse function

$$\delta(x) = - \begin{pmatrix} 0 \\ (1+r)x_2 \end{pmatrix},$$

where $r \in (0, 1)$ is a constant. Apply this impulse function at each impulse and switching instants. Consider the case that all g_i are equal. Then according to Example 3.2.6, the impulsive switched system enjoys a common Lyapunov function given by

$$V(x) = G(x_1) + \frac{x_2^2}{2}.$$

It is easy to check that Assumption 3.2.1 is satisfied. Therefore, if g_i and h_i satisfy the assumptions (i)–(iv) in Example 3.2.6, then, according to Theorem 3.2.2, all the trivial solution of the resulting impulsive switched system is globally asymptotically stable with respect to $\mathcal{S}_{\text{weak}}(\tau)$ for any $\tau > 0$. Moreover, if g_i and h_i satisfy the assumptions (i)–(ii)

and (iii')–(iv'') in Example 3.2.6, then, according to Theorem 3.2.2, all the trivial solution of the resulting impulsive switched system is globally asymptotically stable with respect to $\mathcal{S}_{\text{weak}}^i(\tau)$ for any $\tau > 0$. \square

3.2.5 An Application to Hybrid Epidemic Dynamics

In this section, we present an application of the main results to investigate a switched SEIR model with pulse treatment. The model is given by an impulsive switched system as follows.

$$\begin{cases} \dot{S} = \mu_{i_k} - \beta_{i_k}SI - \mu_{i_k}S, \\ \dot{E} = \beta_{i_k}SI - a_{i_k}E - \mu_{i_k}E, \\ \dot{I} = \beta_{a_k}E - g_{i_k}I - \mu_{i_k}I, \\ \dot{R} = g_{i_k}I - \mu_{i_k}R, \end{cases} \quad t \in (t_k, t_{k+1}), \quad (3.2.8a)$$

$$\begin{cases} S(t_k) = S(t_k^-), \\ E(t_k) = (1 - j_k)E(t_k^-), \\ I(t_k) = (1 - j_k)I(t_k^-), \\ R(t_k) = R(t_k^-) + j_kE(t_k^-) + j_kI(t_k^-), \end{cases} \quad t \neq t_k, \quad (3.2.8b)$$

where S represents the susceptibles, E those exposed but not yet infectious, I the infectives, and R the removed. System (3.2.8) is a variant of the standard SEIR model by considering seasonality in the model parameters (e.g., the contact rates in the winter is higher than in other seasons) and pulse treatment as a control mechanism. Both seasonality and pulse treatment have been considered in the recent work in [114] (see also [166]). The total population is kept constant and assumed to be normalized to $S + E + I + R = 1$. The variables S, E, I , and R are all positive and always take values in the meaningful domain

$$\Omega_{\text{SEIR}} := \{(S, E, I, R) \in \mathcal{R}^+ \times \mathcal{R}^+ \times \mathcal{R}^+ \times \mathcal{R}^+ : S + E + I + R = 1\}.$$

Each $i_k \in \mathcal{I}$ and \mathcal{I} is a finite index set. Each j_k is a real number in $[0, 1]$, representing a fraction of the population which is treated and removed at time $t = t_k$. The coefficients μ_i represent the birth and death rates, β_i the contact rates, g_i the removal rates, and $1/a_i$ the latent periods; these constants are all positive and allowed to fluctuate seasonally. Choose a family of multiple Lyapunov functions $\{V_i : i \in \mathcal{I}\}$ as $V_i(E, I) = a_iE + (a_i + \mu_i)I$.

Differentiating V_i along the i th mode of (3.2.8) gives

$$\begin{aligned} V_i'(E, I) &= a_i(\beta_i SI - a_i E - \mu_i E) + (a_i + \mu_i)(\beta_a E - g_i I - \mu_i I) \\ &= (R_i S - 1)(\mu_i + g_i)(\mu_i + a_i)I, \end{aligned} \quad (3.2.9)$$

where

$$R_i = \frac{\beta_i a_i}{(\mu_i + g_i)(\mu_i + a_i)}$$

is the i th reproduction number. It is easy to see that (3.2.8) has a disease-free equilibrium $(1, 0, 0, 0)$. We have the following conclusion.

Theorem 3.2.4 *Suppose $R_i \leq 1$ for all $i \in \mathcal{I}$ and Assumption 3.2.1 is satisfied. Then*

- (i) *the disease-free solution of (3.2.8) is globally asymptotically stable (in the meaningful domain) with respect to $\mathcal{S}_{weak}^{i_0}(\tau)$, if $R_{i_0} < 1$ for some $i_0 \in \mathcal{I}$;*
- (ii) *the disease-free solution of (3.2.8) is globally asymptotically stable with respect to $\mathcal{S}_{weak}(\tau)$, if $R_i < 1$ for all $i \in \mathcal{I}$.*

Proof. By (3.2.9), we have $E_{i_0} = \{(S, E, I, R) : I = 0\}$ in case (i). It then can be shown that $M_{i_0} = \{(1, 0, 0, 0)\}$. The conclusions follow from Theorem 3.2.2. \square

Remark 3.2.9 The main role of the pulse treatment is to control the exposed and infectious population by applying treatment at discrete times so that a non-increasing condition on this population, i.e., Assumption 3.2.1, is satisfied. If $a_i \equiv a$ and $\mu_i \equiv \mu$, i.e., the latent period and birth/death rate are both constant, then the multiple Lyapunov functions V_i reduce to a common (weak) Lyapunov function. Therefore, Assumption 3.2.1 is trivially satisfied if we do not introduce pulse treatment, and Theorem 3.2.4 remains true in the absence of pulse treatment, which agrees with the results reported in [166], where the author considers a single switching parameter β_i in the SEIR model without pulse treatment and the stability condition is given by $R_i < 1$ for all $i \in \mathcal{I}$. \square

Simulations. For simulation purpose, we choose two different modes of (3.2.8), motivated by different seasons, e.g., winter and non-winter seasons, and represented by two sets of parameters $\{\mu_1 = 0.2, \beta_1 = 2, g_1 = 1, a_1 = 0.3\}$ and $\{\mu_2 = 0.1, \beta_2 = 1, g_2 = 1, a_2 = 20\}$. The reproduction numbers for the two modes can be calculated as $R_1 = 1$ and $R_2 = 0.9046$. Therefore, without switching and impulses, the disease-free solution of each individual

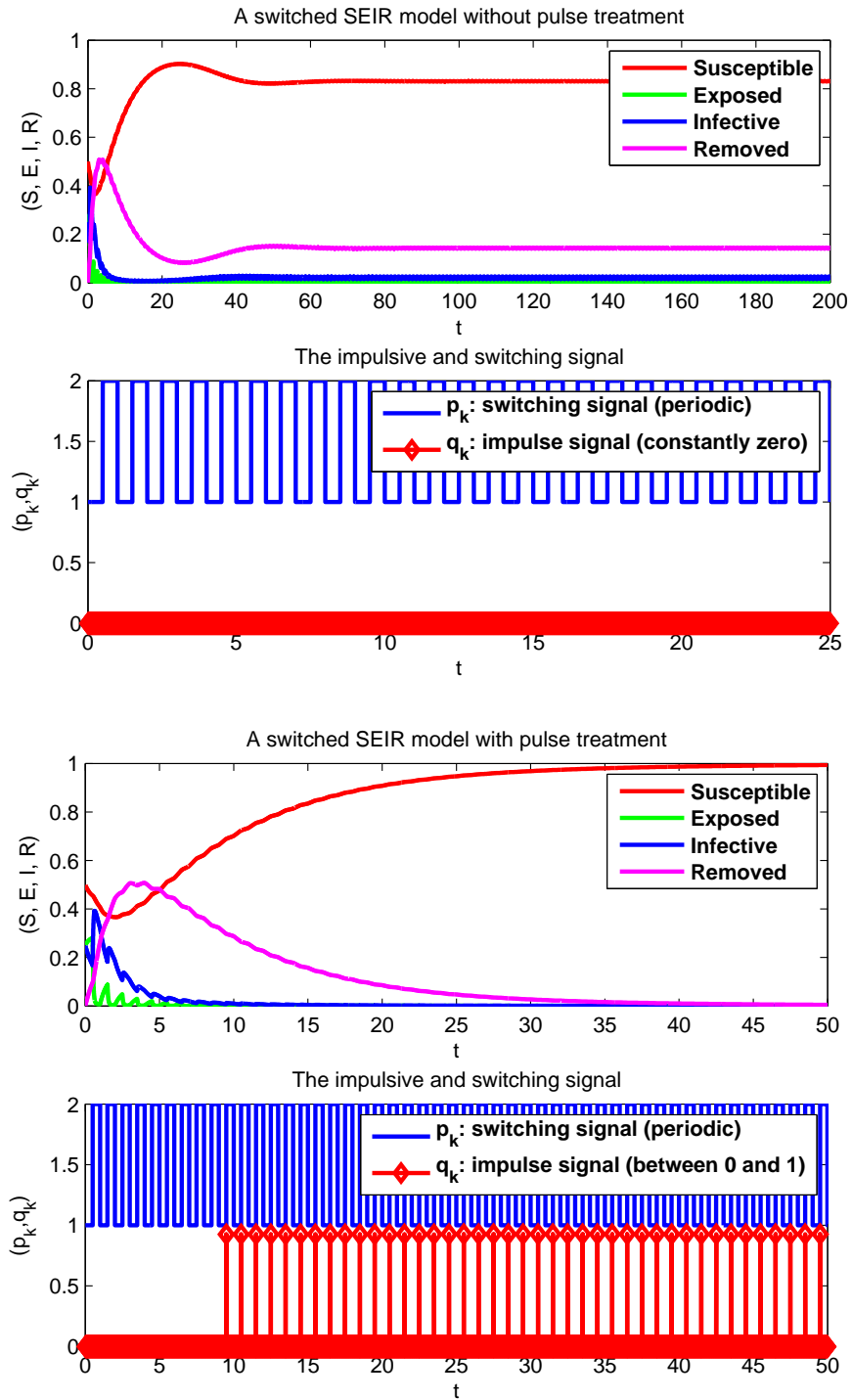

Figure 3.1 Numerical simulations for a switched SEIR model with and without pulse treatment.

mode is globally asymptotically stable [126]. However, if we introduce a periodic switching signal, dwelling equally on the two modes, the simulation results (Figure 3.1) show that the disease persists, if no pulse treatment is given. This is due to a possible violation of Assumption 3.2.1 required by Theorem 3.2.4. If we introduce pulse treatment so that Assumption 3.2.1 is satisfied, then Theorem 3.2.4 can guarantee that the disease-free solution is globally asymptotically stable, i.e., the disease is eradicated by the pulse treatment, which is verified by the simulation results shown in Figure 3.1.

3.3 Input-to-State Stability

The notions of input-to-state stability (ISS) and integral input-to-state stability (iISS), originally introduced in [162] and [163], have proved very useful in characterizing the effects of external inputs to a control system. The ISS/iISS notions are subsequently extended to discrete-time systems in [83] and to switched systems in [135] and [174]. ISS notions for hybrid systems are investigated in [23] and [24], where the hybrid systems are defined on hybrid time domains. More recently, the work of [67] studies Lyapunov conditions for input-to-state stability of impulsive nonlinear systems.

In this section, we will investigate input-to-state stability of impulsive switched systems. In Section 3.3.1, we formulate a nonautonomous impulsive switched system with external inputs and introduce the definitions of (h_0, h) -input-to-state stability ((h_0, h) -ISS) and (h_0, h) -integral-input-to-state stability ((h_0, h) -iISS). Section 3.3.2 provides two lemmas on class- \mathcal{KL} estimates for impulsive switched systems, which are used in Section 3.3.3 to derive the (h_0, h) -ISS results. Section 3.3.4 presents two examples to illustrate the results.

3.3.1 Definitions of (h_0, h) -Input-to-State Stability

Consider the following nonautonomous version of system (3.1.1)

$$\begin{cases} x'(t) = f_{i_k}(t, x(t), u(t)), & t \in (t_k, t_{k+1}), & (3.3.1a) \\ \Delta x(t) = I_{j_k}(t, x(t^-), u(t)), & t = t_k, & (3.3.1b) \\ x(t_0) = x_0, & & (3.3.1c) \end{cases}$$

where $u : \mathcal{R}^+ \rightarrow \mathcal{R}^m$ is the system input function, which is assumed to be measurable and locally essentially bounded. For each $i \in \mathcal{I}$, the function $f_i \in C(\mathcal{R}^+ \times \mathcal{R}^n \times \mathcal{R}^m; \mathcal{R}^n)$ and is locally Lipschitzian in (x, u) . For each $j \in \mathcal{J}$, $I_j : \mathcal{R}^+ \times \mathcal{R}^n \times \mathcal{R}^m \rightarrow \mathcal{R}^n$. Each

solution x is continuous at each $t \neq t_k$ for $t > t_0$. We assume that, for each $i \in \mathcal{I}$ and $j \in \mathcal{J}$, $f_i(t, 0, 0) \equiv I_j(t, 0, 0) \equiv 0$ so that system (3.3.1), without input, admits a trivial solution.

Recall the class \mathcal{K} functions and class \mathcal{KL} functions defined in Section 2.2 (page 23) and class Γ functions defined in Section 2.5.1 (page 47). Let $h_0, h \in \Gamma$. We define input-to-state stability in terms of two measures (h_0 and h) as follows.

Definition 3.3.1 System (3.3.1) is said to be **uniformly (h_0, h) -input-to-state stable (ISS)** over a certain class of signals \mathcal{S} , if there exist functions $\beta \in \mathcal{KL}$ and $\gamma \in \mathcal{K}_\infty$, independent of the choice of impulsive and switching signals $\{(t_k, i_k, j_k)\}$ in \mathcal{S} , such that, for each $x_0 \in \mathcal{R}^n$ and input function u , the solution x of (3.3.1) exists globally and satisfies

$$h(t, x(t)) \leq \beta(h_0(t_0, x_0), t - t_0) + \gamma\left(\sup_{t_0 \leq s \leq t} |u(s)|\right).$$

Definition 3.3.2 System (3.3.1) is said to be **uniformly (h_0, h) -integral-input-to-state stable $((h_0, h)$ -ISS)** over a certain class of signals \mathcal{S} , if there exist functions $\beta \in \mathcal{KL}$ and $\alpha, \gamma \in \mathcal{K}_\infty$, independent of the choice of impulsive and switching signals $\{(t_k, i_k, j_k)\}$ in \mathcal{S} , such that, for each $x_0 \in \mathcal{R}^n$ and input function u , the solution x of (3.3.1) exists globally and satisfies

$$\alpha(h(t, x(t))) \leq \beta(h_0(t_0, x_0), t - t_0) + \int_{t_0}^t \gamma(|u(s)|) ds + \sum_{t_0 < t_k \leq t} \gamma(|u(t_k)|).$$

The above definitions generalize the classical notions of ISS and iISS for the ordinary system given in [162] and [163], and those for impulsive systems given in [67]. The (h_0, h) -stability notions are considered here in the spirit of the work in [100] to unify different notions of stability. It is worth noting that this notion has been adopted in the framework of switched systems in [34], but not yet exploited for ISS/iISS stability.

To investigate the ISS/iISS properties of system (3.3.1), which has different modes of the continuous dynamics given by $\{f_i : i \in \mathcal{I}\}$, we shall choose accordingly a family of multiple Lyapunov functions $\{V_i : i \in \mathcal{I}\}$, where each $V_i \in C(\mathcal{R}^+ \times \mathcal{R}^n; \mathcal{R}^+)$ and is locally Lipschitzian in its second variable. We will employ the upper right-hand derivative of V_i with respect to the i th mode of system (3.3.1), for each $i \in \mathcal{I}$, at $(t, x) \in \mathcal{R}^+ \times \mathcal{R}^n$ by

$$D^+ V_i(t, x) = \limsup_{h \rightarrow 0^+} \frac{1}{h} [V_i(t + h, x + h f_i(t, x, u)) - V_i(t, x)], \quad (3.3.2)$$

where $u \in \mathcal{R}^m$. Moreover, for a function $m : \mathcal{R} \rightarrow \mathcal{R}$, $D^+ m(t)$, the upper right-hand derivative of $m(t)$, is defined by $D^+ m(t) = \limsup_{h \rightarrow 0^+} \frac{1}{h} [m(t + h) - m(t)]$.

Let $\{(t_k, i_k, j_k)\}$ be an impulsive switching signal and x be a solution to system (3.3.1) on $[t_k, t_{k+1})$. Define $m(t) = V_{i_k}(t, x(t))$, for $t \in [t_k, t_{k+1})$. The above definitions for upper right-hand derivatives are connected by the relation

$$D^+m(t) = D^+V_{i_k}(t, x(t)), \quad t \in (t_k, t_{k+1}),$$

because $\{V_i : i \in \mathcal{I}\}$ are locally Lipschitzian in x . Note that similar definitions have already been introduced in Section 2.2 for switched nonlinear systems without input.

3.3.2 Class- \mathcal{KL} Estimates

In this subsection, we establish two general class- \mathcal{KL} estimates for solutions of scalar impulsive switched systems.

Lemma 3.3.1 *Consider the scalar impulsive switched system*

$$\begin{cases} y'(t) = p_{i_k}(t)\alpha_{i_k}(y(t)), & t \in (t_k, t_{k+1}), \quad i_k \in \mathcal{I}, \quad k \in \mathcal{Z}^+, & (3.3.3a) \\ y(t_k) = g(y(t_k^-)), & t = t_k, \quad k \in \mathcal{Z}^+ \setminus \{0\}, & (3.3.3b) \\ y(t_0) = y_0, & & (3.3.3c) \end{cases}$$

where $y_0 \geq 0$, $g \in \mathcal{K}_\infty$, $p_i : \mathcal{R}^+ \rightarrow \mathcal{R}^+$ is locally integrable, and $\alpha_i \in \mathcal{K}$ is locally Lipschitz for each $i \in \mathcal{I}$. If

- (i) $\tau_i := \sup \{t_k - t_{k-1} : k \in \mathcal{Z}^+, i_k = i\} < \infty$; and
- (ii) $N_i := \inf_{q>0} \int_{g(q)}^q \frac{ds}{\alpha_i(s)} > M_i := \sup_{t \geq 0} \int_t^{t+\tau_i} p_i(s) ds$,

then the system has a unique solution $y(t)$ defined for all $t \geq t_0$ and there exists a class- \mathcal{KL} function β such that

$$y(t) \leq \beta(y_0, t - t_0).$$

Proof. Note that $y(t) \geq 0$ for all $t \geq t_0$. We first show that

- (i) Given any $\varepsilon > 0$, there is $\delta = \delta(\varepsilon)$ such that $y_0 \leq \delta$ implies $y(t) \leq \varepsilon$ for all $t \geq t_0$.
- (ii) Given any $r > 0$ and $\eta > 0$, there exists $T = T(\eta, r) \geq 0$ (dependent on η and r , but independent of t_0) such that $y(t) < \eta$ for all $t \geq t_0 + T$.

To show part (i), pick $\delta = \delta(\varepsilon) = g(\varepsilon)$ for any given $\varepsilon > 0$. The conditions on N_i shows that $0 < g(q) < q$ for all $q > 0$. We claim that if $y_0 \leq \delta$, then $y(t)$ is defined for all $t \geq t_0$ and $y(t) \leq \varepsilon$. Suppose $y(t; t_0, y_0)$ is continued to its maximal interval of existence $[t_0, \beta)$. If $\beta < \infty$, there must exist some $t \in (t_0, \beta)$ such that $y(t) > \varepsilon$. We shall show that $y(t) \leq \varepsilon$ for all $t \in [t_0, \beta)$, which in turn will imply that $\beta = \infty$ and therefore part (i) is proved.

Suppose for the sake of contradiction that $y(t) > \varepsilon$ for some $t \in [t_0, \beta)$. Let $t^* = \inf \{t \in [t_0, \beta) : y(t) > \varepsilon\}$. It is clear that $y(t) \leq \varepsilon$ for all $t \in [t_0, t^*)$. Moreover, either $y(t^*) = \varepsilon$ or $y(t^*) > \varepsilon$ and $t^* = t_k$ for some k . In either case, $y(t)$ is defined for all $t \in [t_0, t^*]$. Since $y_0 \leq \delta = g(\varepsilon) < \varepsilon$ and $y(t^*) \geq \varepsilon$, then $t^* > t_0$. Moreover, $y(t) < \varepsilon$ for $t \in [t_0, t^*)$. We claim that $t^* \neq t_k$ for any $k \geq 1$ and hence $y(t^*) = \varepsilon$. Actually if $t^* \neq t_k$ for some $k \geq 1$, then $0 < \varepsilon \leq y(t^*) = g(y(t^{*-})) < y(t^{*-}) \leq \varepsilon$, which is impossible.

Now suppose that $t^* \in (t_k, t_{k+1})$ for some k . Since $y(t) < \varepsilon$ for $t \in [t_0, t^*)$, we have $y(t_k) = g(y(t_k^-)) < g(\varepsilon)$. Integrating (3.3.3a) on $[t_k, t^*]$ gives

$$N_{i_k} \leq \int_{g(\varepsilon)}^{\varepsilon} \frac{ds}{c(s)} \leq \int_{y(t_k)}^{y(t^*)} \frac{ds}{\alpha_{i_k}(s)} \leq \int_{t_k}^{t^*} p_{i_k}(s) ds \leq \int_{t_k}^{t_k + \tau_{i_k}} p_{i_k}(s) ds \leq M_{i_k},$$

which clearly contradicts with condition (iv). This completes the proof for part (i).

We proceed to show part (ii). Let $r > 0$ and $\eta > 0$ be arbitrarily given. Following the proof of part (i), we can show that there exists some $\rho = \rho(r)$ such that $y(t) \leq \rho$ for all $t \geq t_0$ if $y_0 \leq r$. Actually we can choose $\rho = g^{-1}(r)$, which is always possible since $g \in \mathcal{K}_\infty$. Then repeating the proof of uniform stability shows $y(t) \leq \rho$ for all $t \geq t_0$.

Let $\delta = \delta(\eta) = g(\eta)$. From part (i), $y_0 \leq \delta$ implies that $y(t) \leq \eta$ for all $t \geq t_0$, where t_0 can be arbitrary. Without loss of generality, we can assume $\eta < \rho$. Define

$$L_i = L_i(\gamma) = \sup \left\{ \frac{1}{\alpha_i(s)} : g(\delta) \leq s \leq \rho \right\}.$$

It is clear that $0 < L_i < \infty$. For $\delta \leq q \leq \rho$, we have $g(\delta) \leq g(q) < q \leq \rho$ and so

$$N_i \leq \int_{g(q)}^q \frac{ds}{\alpha_i(s)} \leq L_i[q - g(q)],$$

from which we can obtain $g(q) \leq q - N_i/L_i < q - d$, where $d = d(\eta, r) > 0$ is chosen so that $d < \inf_{i \in \mathcal{I}} (N_i - M_i)/L_i$. Let $\tau = \sup_{i \in \mathcal{I}} \tau_i$. Choose $T = \tau(N + 1)$, where N is the first integer such that $N > \rho/d$. Then T depends on τ, r , and η , but is independent of t_0 .

Claim. There exists some $t \in [t_0, t_0 + T]$ such that $|x(t)| \leq \delta$.

Note that the conclusion of part (ii) would follow from this claim and part (i).

Proof of the Claim. Suppose it is not true. Then $y(t) > \delta$ for all $t \in [t_0, t_0 + T]$. We prove by induction that, for $[t_k, t_{k+1}) \subset [t_0, t_0 + T]$, where $k \in \mathcal{Z}^+$, we have $y(t) \leq A_k := \rho - kd$. By the choice of T , there are at least $N + 1$ such intervals, where $N > \rho/d$, which would eventually lead to $y(t) \leq \rho - Nd < 0$ on $[t_N, t_{N+1})$, a clear contradiction.

On $[t_0, t_1)$, we have $m(t) \leq A_0 = \rho$. Suppose that $0 < \delta < y(t) \leq A_k \leq \rho$ on $[t_k, t_{k+1})$, $k < N$. Assume for the sake of contradiction that there exists some $t \in [t_{k+1}, t_{k+2})$ such that $y(t) > A_k - d = A_{k+1}$. Let $t^* = \inf \{t \in [t_{k+1}, t_{k+2}) : y(t) > A_k - d\}$. Since $y(t_{k+1}) = g(y(t_{k+1}^-)) \leq g(A_k) < A_k - d$, we have $t^* \in (t_{k+1}, t_{k+2})$ and $y(t^*) = A_k - d$. Integrating (3.3.3a) on $[t_{k+1}, t^*]$ gives

$$\int_{y(t_{k+1})}^{y(t^*)} \frac{ds}{\alpha_{i_{k+1}}(s)} \leq \int_{t_{k+1}}^{t^*} p_{i_{k+1}}(s) ds \leq \int_{t_{k+1}}^{t_{k+1}+\tau} p_{i_{k+1}}(s) ds \leq M_{i_{k+1}},$$

and

$$\begin{aligned} \int_{y(t_{k+1})}^{y(t^*)} \frac{ds}{\alpha_{i_{k+1}}(s)} &\geq \int_{g(A_k)}^{A_k-d} \frac{ds}{\alpha_{i_{k+1}}(s)} = \int_{g(A_k)}^{A_k} \frac{ds}{\alpha_{i_{k+1}}(s)} - \int_{A_k-d}^{A_k} \frac{ds}{\alpha_{i_{k+1}}(s)} \\ &\geq N_{i_{k+1}} - dL_{i_{k+1}} > M_{i_{k+1}}. \end{aligned}$$

Again, we reach a contradiction. Therefore, the claim is proved and so are both parts (i) and (ii). Following a standard argument, a class- \mathcal{KL} function β can be constructed based on parts (i) and (ii). \square

Lemma 3.3.2 Consider the scalar impulsive switched system

$$\begin{cases} y'(t) = -p_{i_k}(t)\alpha_{i_k}(y(t)), & t \in (t_k, t_{k+1}), \quad i_k \in \mathcal{I}, \quad k \in \mathcal{Z}^+, \end{cases} \quad (3.3.4a)$$

$$\begin{cases} y(t_k) = g(y(t_k^-)), & t = t_k, \quad k \in \mathcal{Z}^+ \setminus \{0\}, \end{cases} \quad (3.3.4b)$$

$$\begin{cases} y(t_0) = y_0, \end{cases} \quad (3.3.4c)$$

where $y_0 \geq 0$, $g \in \mathcal{K}_\infty$ with $g(s) > s$ for all $s > 0$, $p_i : \mathcal{R}^+ \rightarrow \mathcal{R}^+$ is locally integrable, and $\alpha_i \in \mathcal{K}$ is locally Lipschitz for each $i \in \mathcal{I}$. If

$$(i) \quad \tau_i := \inf \{t_k - t_{k-1} : k \in \mathcal{Z}^+, i_k = i\};$$

$$(ii) \quad N_i := \inf_{t \geq 0} \int_t^{t+\tau_i} p_i(s) ds > M_i := \sup_{q > 0} \int_q^{g(q)} \frac{ds}{\alpha_i(s)},$$

then the system has a unique solution $y(t)$ defined for all $t \geq t_0$ and there exists a class- \mathcal{KL} function β such that

$$y(t) \leq \beta(y_0, t - t_0).$$

Proof. We prove the same statements as parts (i) and (ii) in the proof of Lemma 3.3.1. Note that $0 < M_i < N_i < \infty$ for all $i \in \mathcal{I}$. For part (i), we choose $\delta = \delta(\varepsilon) = g^{-1}(\varepsilon) < \varepsilon$. We show that if $y_0 \leq \delta$, then $y(t)$ is defined for all $t \geq t_0$ and $y(t) \leq \varepsilon$. Suppose $y(t; t_0, y_0)$ is continued to its maximal interval of existence $[t_0, \beta)$. If $\beta < \infty$, there must exist some $t \in (t_0, \beta)$ such that $y(t) > \varepsilon$. We shall show that $y(t) \leq \varepsilon$ for all $t \in [t_0, \beta)$, which in turn will imply that $\beta = \infty$ and therefore part (i) is proved.

Suppose for the sake of contradiction that $y(t) > \varepsilon$ for some $t \in [t_0, \beta)$. Let $t^* = \inf \{t \in [t_0, \beta) : y(t) > \varepsilon\}$. It is clear that $y(t) \leq \varepsilon$ for all $t \in [t_0, t^*)$. Moreover, either $y(t^*) = \varepsilon$ or $y(t^*) > \varepsilon$ and $t^* = t_k$ for some k . In either case, $y(t)$ is defined for all $t \in [t_0, t^*]$. Since $y_0 \leq \delta = g^{-1}(\varepsilon) < \varepsilon$ and $y(t^*) \geq \varepsilon$, then $t^* > t_0$. Moreover, $y(t) < \varepsilon$ for $t \in [t_0, t^*)$. Suppose that $t^* \in [t_k, t_{k+1})$. Equation (3.3.4a) implies that $y(t)$ is decreasing on $[t_k, t^*]$. Therefore $t^* = t_k$. We then show that $y(t_k^-) \leq g^{-1}(\varepsilon)$. Suppose this is not true. Then we have $g^{-1}(\varepsilon) < y(t) \leq \varepsilon$ on $[t_{k-1}, t_k)$. Integrating (3.3.4a) on $[t_{k-1}, t_k)$ gives

$$\int_{y(t_k^-)}^{y(t_{k-1})} \frac{ds}{\alpha_{i_{k-1}}(s)} \geq \int_{t_{k-1}}^{t_k} p_{i_{k-1}}(s) ds \geq \int_{t_{k-1}}^{t_{k-1} + \tau_{i_{k-1}}} p_{i_{k-1}}(s) ds \geq N_{i_{k-1}},$$

and

$$\int_{y(t_k^-)}^{y(t_{k-1})} \frac{ds}{\alpha_{i_{k-1}}(s)} \leq \int_{g^{-1}(\varepsilon)}^{g(g^{-1}(\varepsilon))} \frac{ds}{\alpha_{i_{k-1}}(s)} \leq M_{i_{k-1}} < N_{i_{k-1}},$$

which gives a contradiction in view of condition (ii). Therefore, $y(t_k^-) = y(t_k^-) \leq g^{-1}(\varepsilon)$ and $y(t_k^*) = g(y(t_k^-)) \leq \varepsilon$. But $y(t_k^*) \geq \varepsilon$. We must have $y(t_k^*) = \varepsilon$. However, $y(t)$ is decreasing on $[t_k^*, t_{k+1})$ and therefore $y(t) \leq \varepsilon$ on $[t_k^*, t_{k+1})$, which contradicts the definition of t^* . This completes the proof for part (i).

We proceed to show part (ii). Let $r > 0$ and $\eta > 0$ be arbitrarily given. Following the proof of part (i), we can show that there exists some $\rho = \rho(r)$ such that $y(t) \leq \rho$ for all $t \geq t_0$ if $y_0 \leq r$. Actually we can choose $\rho = g(r)$, which is always possible since $g \in \mathcal{K}_\infty$. Then repeating the proof of uniform stability shows $y(t) \leq \rho$ for all $t \geq t_0$.

Let $\delta = \delta(\eta) = g^{-1}(\eta)$. From part (i), $y_0 \leq \delta$ implies that $y(t) \leq \eta$ for all $t \geq t_0$, where t_0 can be arbitrary. Without loss of generality, we can assume $\eta < \rho$. Define

$$L_i = L_i(\eta) = \sup \left\{ \frac{1}{\alpha_i(s)} : \delta \leq s \leq \rho \right\}.$$

It is clear that $0 < L_i < \infty$. Let $d = \inf_{i \in \mathcal{I}} (N_i - M_i)/L_i$, $\tau = \sup_{i \in \mathcal{I}} \tau_i$, and N be an integer such that $N > \rho/d$. Choose $T = (N + 1)^2 \tau$.

Claim. There exists some $t \in [t_0, t_0 + T]$ such that $|x(t)| \leq \delta$.

Note that the conclusion of part (ii) would follow from this claim and part (i).

Proof of the Claim. Suppose it is not true. Then $\delta < y(t) \leq \rho$ for all $t \in [t_0, t_0 + T]$. By the choice of T , there are two possible cases: (I) there are at least N impulse times t_k , $k \geq 1$, in $[t_0, t_0 + T]$; (II) there are at least one subinterval of $[t_0, t_0 + T]$ with length greater than $N\tau$ which does not contain any impulse time. In either case, we will derive a contradiction.

Consider case (I) first. We show that by induction that $y(t_k^-) \leq g^{-1}(\rho) - kd$, where $1 \leq k \leq N$. Eventually this would lead to $y(t_N^-) \leq g^{-1}(\rho) - Nd < 0$, which is not impossible. We first show that $y(t_1^-) \leq g^{-1}(\rho) - d$. Integrating (3.3.4a) on $[t_0, t_1]$ gives

$$\int_{y(t_1^-)}^{y_0} \frac{ds}{\alpha_{i_0}(s)} = \int_{g^{-1}(\rho)}^{\rho} \frac{ds}{\alpha_{i_0}(s)} + \int_{y(t_1^-)}^{g^{-1}(\rho)} \frac{ds}{\alpha_{i_0}(s)} \leq M_{i_0} + \int_{y(t_1^-)}^{g^{-1}(\rho)} \frac{ds}{\alpha_{i_0}(s)},$$

and

$$\int_{y(t_1^-)}^{y_0} \frac{ds}{\alpha_{i_0}(s)} \geq \int_{t_0}^{t_1} p_{i_0}(s) ds \geq \int_{t_0}^{t_0 + \tau_{i_0}} p_{i_0}(s) ds \geq N_{i_0},$$

which gives

$$M_{i_0} + \int_{y(t_1^-)}^{g^{-1}(\rho)} \frac{ds}{\alpha_{i_0}(s)} \geq N_{i_0}. \quad (3.3.5)$$

Condition (ii) implies that

$$\int_{y(t_1^-)}^{g^{-1}(\rho)} \frac{ds}{\alpha_{i_0}(s)} > 0,$$

which in turn implies $\rho > g^{-1}(\rho) > y(t_1^-) \geq \delta$. Therefore, by the definition of L_{i_0} ,

$$\int_{y(t_1^-)}^{g^{-1}(\rho)} \frac{ds}{\alpha_{i_0}(s)} \leq [g^{-1}(\rho) - y(t_1^-)] L_{i_0}.$$

Combining this and equation (3.3.5) gives

$$[g^{-1}(\rho) - y(t_1^-)] L_{i_0} + M_{i_0} \geq N_{i_0},$$

which eventually gives

$$y(t_1^-) \leq g^{-1}(\rho) - \frac{N_{i_0} - M_{i_0}}{L_{i_0}} \leq g^{-1}(\rho) - d.$$

Now we have $y(t_1^-) \leq g^{-1}(\rho) - d$ and $y(t_1) = g(y(t_1^-)) \leq g(g^{-1}(\rho) - d)$. Repeating the same argument on $[t_1, t_2)$, we can show $y(t_2^-) \leq g^{-1}(y(t_1)) - d \leq g^{-1}(\rho) - 2d$. By induction, this shows $y(t_k^-) \leq g^{-1}(\rho) - kd$, where $1 \leq k \leq N$, and $y(t_N^-) \leq g^{-1}(\rho) - Nd < 0$, a contradiction.

Now consider case (II). Suppose $[t_k, t^*)$ is an interval in $[t_0, t_0 + T]$ without any impulse, where t^* can be $t_0 + T$. Since $t^* - t_k \geq N\tau$, we can break this interval into N intervals, each with a length greater than τ . Label these intervals as $[s_0, s_1], [s_1, s_2], \dots, [s_{N-1}, s_N]$, where $s_0 = t_k$ and $s_N = t^*$. Repeating the same argument as in case (I), we can show $y(s_1^-) \leq g^{-1}(y(s_0)) - d$. Since $y(t)$ is continuous at s_1 , we have $y(s_1) = y(s_1^-) \leq g^{-1}(y(s_0)) - d < y(s_0) - d$. By induction, we can show $y(s_N^-) \leq y(s_0) - Nd \leq \rho - Nd < 0$, again a contradiction. Therefore, the claim is proved and so are both parts (i) and (ii). Following a standard argument as in the proof of Lemma 3.3.1, a class- \mathcal{KL} function β can be constructed based on parts (i) and (ii). The proof is complete. \square

3.3.3 Input-to-State Stability

In this subsection, we establish some sufficient conditions for input-to-state stability of impulsive switched systems, as applications of the class- \mathcal{KL} estimates we have obtained in the previous section. To unify different notions of stability, the stability analysis is performed in terms of two measures (h_0 and h).

Theorem 3.3.1 *Suppose that there exist a family of functions $\{V_i : i \in \mathcal{I}\}$ in $C(\mathcal{R}^+ \times \mathcal{R}^n, \mathcal{R}^+)$ that are locally Lipschitzian in the second variable, functions a, b, g , and χ of class \mathcal{K}_∞ , $p_i : \mathcal{R}^+ \rightarrow \mathcal{R}^+$ locally integrable and $\alpha_i \in \mathcal{K}$ locally Lipschitz for each $i \in \mathcal{I}$, and positive constants τ_i ($i \in \mathcal{I}$) such that, for all $i, \hat{i} \in \mathcal{I}, j \in \mathcal{J}$, and $(t, x, u) \in \mathcal{R}^+ \times \mathcal{R}^n \times \mathcal{R}^m$,*

$$(i) \quad a(h(t, x)) \leq V_i(t, x) \leq b(h_0(t, x));$$

$$(ii) \quad D^+ V_i(t, x) \leq p_i(t) c_i(V_i(t, x)) \text{ if } V_i(t, x) \geq \chi(|u|);$$

$$(iii) \quad V_i(t, x + I_j(t, x, u)) \leq g(V_{\hat{i}}(t^-, x)) \text{ if } V_{\hat{i}}(t^-, x) \geq \chi(|u|), \text{ and } V_i(t, x + I_j(t, x, u)) < \rho(|u|) \text{ if } V_{\hat{i}}(t^-, x) < \chi(|u|); \text{ and}$$

$$(iv) \quad M_i := \sup_{t \geq 0} \int_t^{t+\tau_i} p_i(s) ds < N_i := \inf_{q>0} \int_{g(q)}^q \frac{ds}{c_i(s)}.$$

Then system (3.3.1) is uniformly (h_0, h) -ISS on $\bigcap_{i \in \mathcal{I}} \mathcal{S}_{\sup}^i(\tau_i)$. In particular, system (3.3.1) is uniformly (h_0, h) -ISS on $\mathcal{S}_{\sup}(\tau)$, where $\tau = \inf_{i \in \mathcal{I}} \tau_i$.

Proof. Let $\{(t_k, i_k, j_k) : k \in \mathcal{Z}^+\}$ be a given impulsive and switching signal. Define

$$m(t) := V_{i_k}(t, x(t)), \quad t \in [t_k, t_{k+1}), \quad k \in \mathcal{Z}^+.$$

Let $\|u\|_\infty$ denote the sup norm of the input on \mathcal{R}^+ . Let $\mu = \max(g^{-1} \circ \chi, \rho)$ and $C = \mu(\|u\|_\infty)$.

Claim. If $m(T) \leq g(C)$ for some $T \geq t_0$, then $m(t) \leq C$ for all $t \geq T$.

Proof of the Claim. Suppose this is not true. Note that $g(C) < C$. Let

$$t^* := \inf \{t \geq T : m(t) > C\}.$$

Then $t^* \in [t_k, t_{k+1})$ for some k . Define

$$t_* := \sup \{t \in [t_k, t^*] : m(t) \leq g(C)\}.$$

Then $t^* \geq t_* \geq t_k$. We show that $t^* > t_*$. If $t^* = t_*$, then we must have $t^* = t_* = t_k$ by continuity of $m(t)$ on (t_*, t^*) . If $m(t_k^-) \geq \chi(\|u\|_\infty)$, condition (iii) implies that $m(t_k) \leq g(m(t_k^-)) \leq g(C) < C$, which contradicts the definition of t^* . If $m(t_k^-) < \chi(\|u\|_\infty)$, condition (iv) implies that $m(t_k) < \rho(\|u\|_\infty)$, which also contradicts the definition of t^* . Therefore, $t^* > t_*$. By continuity, we have $m(t^*) = C$ and $m(t_*) = g(c)$. Moreover, we have $g(C) \leq m(t) \leq C$ on $[t_*, t^*] \subset [t_k, t_{k+1})$, which implies that $m(t) \geq \chi(\|u\|_\infty)$. Condition (ii) implies that

$$D^+ m(t) \leq p_{i_k}(t)m(t), \quad t \in [t_*, t^*].$$

By integration, this differential inequality gives

$$N_{i_k} \leq \int_{g(C)}^C \frac{ds}{c_{i_k}(s)} = \int_{m(t_*)}^{m(t^*)} \frac{ds}{c_{i_k}(s)} \leq \int_{t_*}^{t^*} p_{i_k}(s) ds \leq \int_{t_*}^{t_*+\tau} p_{i_k}(s) ds \leq M_{i_k},$$

which contradicts condition (iv). The claim is proved.

Let $\bar{t} = \inf \{t \geq t_0 : m(t) \leq g(C)\}$. It follows from the above claim that $m(t) \leq C$ for all $t \geq \bar{t}$, which implies

$$|h(t, x(t))| \leq a^{-1} \circ \mu(\|u\|_\infty), \quad t \geq \bar{t}. \quad (3.3.6)$$

For $t < \bar{t}$, we have $m(t) > g(C)$, which implies $m(t) \geq \chi(\|u\|_\infty)$ for all $t \leq \bar{t}$. Consequently, conditions (ii) and (iii) imply that

$$D^+ m(t) \leq p_{i_k}(t)m(t), \quad t \in (t_k, t_{k+1}), \quad t \leq \bar{t},$$

and

$$m(t) \leq g(m(t^-)), \quad t = t_k, \quad t \leq \bar{t}.$$

Using Lemma 3.3.1 and a comparison principle for impulsive differential equation (see, e.g., Theorem 2.6.1 of [97]), there exists a function $\hat{\beta} \in \mathcal{KL}$ such that

$$m(t) \leq \hat{\beta}(m(t_0), t - t_0), \quad t_0 \leq t \leq \bar{t},$$

which implies

$$h(t, x(t)) \leq a^{-1} \circ \hat{\beta}(b(h_0(t, x(t))), t - t_0), \quad t_0 \leq t \leq \bar{t}, \quad (3.3.7)$$

Let $\gamma(r) = a^{-1}(\max(g^{-1}(\chi(r)), \rho(r)))$ and $\beta(r, s) = a^{-1}(\hat{\beta}(b(r), s))$ for $(r, s) \in \mathcal{R}^+ \times \mathcal{R}^+$. Then $\gamma \in \mathcal{K}_\infty$ and $\beta \in \mathcal{KL}$. Combining (3.3.6) and (3.3.7) gives

$$h(t, x(t)) \leq \beta(h_0(t, x(t)), t - t_0) + \gamma(\|u\|_\infty), \quad t \geq t_0.$$

This guarantees that $x(t)$ is defined for all $t \geq t_0$. Since both β and γ are independent of a particular choice of signal $\{(t_k, i_k, j_k)\}$ in $\mathcal{S}_{\text{sup}}^i(\tau)$, we have established (h_0, h) -uniform ISS of (3.3.1) on $\mathcal{S}_{\text{sup}}^i(\tau)$. The proof is complete. \square

Theorem 3.3.2 *Suppose that there exist a family of functions $\{V_i : i \in \mathcal{I}\}$ in $C(\mathcal{R}^+ \times \mathcal{R}^n; \mathcal{R}^+)$ that are locally Lipschitzian in the second variable, functions a, b, g , and χ of class \mathcal{K}_∞ , $p_i : \mathcal{R}^+ \rightarrow \mathcal{R}^+$ locally integrable and $\alpha_i \in \mathcal{K}$ locally Lipschitz for each $i \in \mathcal{I}$, and positive constants τ_i ($i \in \mathcal{I}$) such that, for all $i, \hat{i} \in \mathcal{I}, j \in \mathcal{J}$, and $(t, x, u) \in \mathcal{R}^+ \times \mathcal{R}^n \times \mathcal{R}^m$,*

(i) $a(h(t, x)) \leq V_i(t, x) \leq b(h_0(t, x));$

(ii) $D^+ V_i(t, x) \leq -p_i(t)c_i(V_i(t, x))$ if $V_i(t, x) \geq \chi(|u|);$

(iii) $V_i(t, x + I_j(t, x, u)) \leq g(V_{\hat{i}}(t^-, x))$ if $V_{\hat{i}}(t^-, x) \geq \chi(|u|)$, and $V_i(t, x + I_j(t, x, u)) < \rho(|u|)$ if $V_{\hat{i}}(t^-, x) < \chi(|u|);$ and

(iv) $N_i := \inf_{t \geq 0} \int_t^{t+\tau_i} p_i(s) ds > M_i := \sup_{q > 0} \int_q^{g(q)} \frac{ds}{c_i(s)}.$

Then system (3.3.1) is uniformly (h_0, h) -ISS on $\bigcap_{i \in \mathcal{I}} \mathcal{S}_{\text{sup}}^i(\tau_i)$. In particular, system (3.3.1) is uniformly (h_0, h) -ISS on $\mathcal{S}_{\text{sup}}(\tau)$, where $\tau = \inf_{i \in \mathcal{I}} \tau_i$.

Proof. Let $\{(t_k, i_k, j_k) : k \in \mathcal{Z}^+\}$ be a given impulsive and switching signal. Let $m(t)$ and $\|u\|_\infty$ be the same as in the proof of Theorem 3.3.1. Let $\mu = \max(g \circ \chi, \rho)$ and $C = \mu(\|u\|_\infty)$.

Claim. If $m(T) \leq g^{-1}(C)$ for some $T \geq t_0$, then $m(t) \leq C$ for all $t \geq T$.

Proof of the Claim. Suppose this is not true. Note that $g^{-1}(C) < C$. Let

$$t^* := \inf \{t \geq T : m(t) > C\}.$$

Then $t^* \in [t_k, t_{k+1})$ for some k . We show that $t^* = t_k$. Suppose this is not the case. Then $m(t^*) = C > g^{-1}(C) \geq \chi(\|u\|_\infty)$. Moreover, by continuity of $m(t)$ on (t_k, t_{k+1}) , we have $m(t) > \chi(\|u\|_\infty)$ for $t \in [t^*, t^* + h]$, provided that h is sufficiently small. By condition (ii), $D^+m(t) \leq 0$ and $m(t)$ is decreasing on $[t^*, t^* + h]$, which is a contradiction with the definition of t^* . Therefore, we must have $t^* = t_k$ and $m(t^*) > C$. Moreover, t^* cannot be t_0 . Otherwise, we must have $t^* = T = t_0$, which is impossible.

Now consider the interval $[t_{k-1}, t_k)$. It follows from the definition of t^* that $m(t) \leq C$ on $[t_{k-1}, t_k)$. If $m(t) > g^{-1}(C) \geq \chi(\|u\|_\infty)$ for all $t \in [t_{k-1}, t_k)$, then condition (ii) implies that

$$D^+m(t) \leq p_{i_{k-1}}(t)c_{i_{k-1}}(m(t)), \quad t \in [t_{k-1}, t_k).$$

Integrating this on $[t_{k-1}, t_k)$ gives

$$\int_{m(t_k^-)}^{m(t_{k-1})} \frac{ds}{c_{i_{k-1}}(s)} \geq \int_{t_{k-1}}^{t_k} p_{i_{k-1}}(s) ds \geq \int_{t_{k-1}}^{t_{k-1} + \tau_{i_{k-1}}} p_{i_{k-1}}(s) ds \geq N_{i_{k-1}},$$

and

$$\int_{m(t_k^-)}^{m(t_{k-1})} \frac{ds}{c_{i_{k-1}}(s)} \leq \int_{g^{-1}(C)}^{g^{-1}(C)} \frac{ds}{c_{i_{k-1}}(s)} \leq M_{i_{k-1}} < N_{i_{k-1}}.$$

We have a contradiction in view of condition (iv). If $m(t) < g^{-1}(C)$ for some $t \in [t_{k-1}, t_k)$, let

$$t_* := \sup \{t \in [t_{k-1}, t_k) : m(t) \leq g^{-1}(C)\}.$$

We show that $t_* = t_k$. Suppose this is not the case, then $m(t_*) = g^{-1}(C)$ and

$$m(t) \geq g^{-1}(C) \geq \chi(\|u\|_\infty), \quad t \in [t_*, t_k).$$

Condition (ii) then implies that $m(t)$ is decreasing on $[t_*, t_k)$, which violates the definition of t_* . Therefore, $t^* = t_* = t_k$ and $m(t^{*-}) = m(t_*^-) \leq g^{-1}(C)$. Now if $m(t^{*-}) \geq \chi(\|u\|_\infty)$, condition (iii) implies that $m(t^*) \leq g(m(t^{*-})) \leq g(g^{-1}(C)) \leq C$, which contradicts that

$m(t^*) > C$. If $m(t^{*-}) < \chi(\|u\|_\infty)$, condition (iii) implies that $m(t^*) < \rho(\|u\|_\infty) \leq C$, which also contradicts that $m(t^*) > C$. In either case, we have a contradiction. Therefore, the claim must be true. The rest of the proof is similar to that of Theorem 3.3.1. \square

3.3.4 Examples

Example 3.3.1 Consider the following nonlinear impulsive switched system

$$\begin{cases} x'(t) = -(1 - a_{i_k})\text{sat}(x(t)) + b_{i_k}\text{sat}(u(t)), & t \in (t_k, t_{k+1}), \quad k \in \mathcal{Z}^+, & (3.3.8a) \\ \Delta x(t) = c_{j_k}\text{sat}(u(t)), & t = t_k, \quad k \in \mathcal{Z}^+ \setminus \{0\}, & (3.3.8b) \end{cases}$$

where $a_{i_k}, b_{i_k} \in \{-0.2, -0.1, 0.1, 0.2\}$, $c_{j_k} \in [-\frac{1}{2}, \frac{1}{2}]$, and $\text{sat}(x)$ is a saturation function defined by $\text{sat}(x) = \frac{1}{2}(|x+1| - |x-1|)$ for $x \in \mathcal{R}$.

As an illustrative example, let $h_0 = h = |x|$. To investigate the (h_0, h) -ISS properties³ of (3.3.8), let $\mathcal{I} \triangleq \{1, 2, 3, 4\}$ and $\mathcal{J} \triangleq [-\frac{1}{2}, \frac{1}{2}]$. For $i \in \mathcal{I}$ and $j \in \mathcal{J}$, let $[a_1 \ a_2 \ a_3 \ a_4] = [b_1 \ b_2 \ b_3 \ b_4] = [-0.2 \ -0.1 \ 0.1 \ 0.2]$ and $c_j = j$. Choose a (common) Lyapunov function

$$V_i(t, x) = V(t, x) = \begin{cases} x^2, & |x| \leq 1, \\ e^{2(|x|-1)}, & |x| > 1, \end{cases}$$

for all $i \in \mathcal{I}$. We check that the conditions of Theorem 3.3.2 are satisfied.

- (i) Condition (i) of Theorem 3.3.2 is clearly satisfied, i.e., there exist α and β in \mathcal{K}_∞ such that

$$\alpha(h_0(t, x)) = \alpha(|x|) = V(t, x) \leq \beta(|x|) = \beta(h(t, x)), \quad (t, x) \in \mathcal{R}^+ \times \mathcal{R}^n.$$

- (ii) Next we verify condition (iii) of Theorem 3.3.2. Choose $\chi(s) = 3s^2/2$. Then $V(t^-, x) \geq \chi(|u|)$ implies that $3u^2/4 \leq V(t, x)/2$. Therefore, if $|x + I_j(t, x, u)| \leq 1$ and $V(t, x) \geq \chi(|u|)$, we have

$$V(t, x + I_j(t, x, u)) = [x + j\text{sat}(u)]^2 \leq \frac{3}{2}x^2 + \frac{3}{4}u^2 \leq 2V(t, x).$$

If $|x + I_j(t, x, u)| > 1$, it implies that $|x| > \frac{1}{2}$. We have

$$V(t, x + I_j(t, x, u)) = e^{2|x+j\text{sat}(u)|-2} \leq e^{2|x|-1} \leq \begin{cases} ee^{2(|x|-1)} = eV(t, x), & |x| > 1, \\ 2e|x|^2 = 2eV(t, x), & |x| \in (\frac{1}{2}, 1], \end{cases}$$

³Since $h_0 = h = |x|$, here (h_0, h) -ISS are ISS in the usual sense.

for all $u \in \mathcal{R}^m$, where the inequality $2x^2 > e^{2(x-1)}$, for $x \in (\frac{1}{2}, 1]$, has been used. Moreover, if $V(t^-, x) < \chi(|u|) = 3u^2/2$, then $|x| < \sqrt{3/2}|u|$. It follows that $V(t, x + I_j(t, x, u)) < \rho(|u|)$ with

$$\rho(s) = \max \left\{ \frac{3}{2}u^2, e^{\sqrt{6}s-1} \right\},$$

if $V(t^-, x) < \chi(|u|) = 3u^2/2$. Therefore, condition (iii) is verified with $g(s) = 2s$.

(iii) Now we check condition (ii). With $\chi(s) = 3s^2/2$, if $|x| \leq 1$ and $V(t^-, x) \geq \chi(|u|)$, we have

$$\begin{aligned} D^+ V_i(t, x) &= 2x \left[-(1 - a_i) \text{sat}(x) + b_i \text{sat}(u) \right] \\ &\leq -2(1 - |a_i|)V(t, x) + 2|b_i| \sqrt{V(t, x)} \sqrt{\frac{2}{3}V(t, x)} \\ &\leq -2(1 - |a_i| - |b_i|)V(t, x). \end{aligned}$$

If $|x| > 1$, we have

$$\begin{aligned} D^+ V_i(t, x) &= 2e^{2(|x|-1)} \text{sgn}(x) \left[-(1 - a_i) \text{sat}(x) + b_i \text{sat}(u) \right] \\ &\leq -2(1 - |a_i| - |b_i|)V(t, x), \end{aligned}$$

for all $u \in \mathcal{R}$. Therefore, condition (iii) of Theorem 3.3.1 is satisfied with $p_i(t) \equiv 2(1 - |a_i| - |b_i|)$ and $c_i(s) = \chi(s) = s$.

(iv) Condition (iv) of Theorem 3.3.2 reads

$$2\tau_i(1 - |a_i| - |b_i|) = N_i > M_i = \sup_{q>0} \int_q^{2q} \frac{1}{s} ds = \ln 2. \quad (3.3.9)$$

Now by Theorem 3.3.1, system (3.3.8) is uniformly (h_0, h) -ISS over $\bigcap_{i \in \mathcal{I}} \mathcal{S}_{\text{inf}}^i(\tau_i)$, where all τ_i satisfy inequality (3.3.9). \square

Example 3.3.2 Consider the following networked hybrid control system

$$\begin{cases} x'(t) = A_{i_k} x(t) + f_{i_k}(x(t)) + B_{i_k} w(t), & t \in (t_k, t_{k+1}), \quad k \in \mathcal{Z}^+, & (3.3.10a) \\ y(t) = x(t) + v(t), & t \geq t_0, & (3.3.10b) \\ \hat{x}'(t) = A_{i_k} \hat{x}(t) + \hat{f}_{i_k}(\hat{x}(t)), & t \in [t_k, t_{k+1}), \quad k \in \mathcal{Z}^+, & (3.3.10c) \\ \hat{x}_l(t) = \begin{cases} y_{j_k}(t^-), & l = j_k, \\ \hat{x}_l(t^-), & l \neq j_k, \end{cases} & l \in \{1, 2, \dots, n\}, & (3.3.10d) \end{cases}$$

where $x(t) \in \mathcal{R}^n$ is the system state, $w(t) \in \mathcal{R}^m$ is the disturbance input, $y(t) \in \mathcal{R}^n$ is the state measurement, $v(t) \in \mathcal{R}^n$ is the measurement noise, $\hat{x}(t) \in \mathcal{R}^n$ is the remote estimate of $x(t)$, $f_i(x(t))$ and $\hat{f}_i(\hat{x}(t))$ are the nonlinear delayed perturbations of the state and their estimations, respectively. Moreover, $i_k \in \mathcal{I}$ and \mathcal{I} is a finite index set; $\{t_k\}$ is a monotonically increasing transmission time sequence satisfying $t_k \rightarrow \infty$ as $k \rightarrow \infty$; at each transmission time $t = t_k$, a try-once-discard (TOD)-like protocol [175] to determine the index $j_k \in \{1, 2, \dots, n\}$, i.e., j_k is the index j corresponding to the largest $|\hat{x}_j(t_k^-) - y_j(t_k^-)| = |e_j(t_k^-) - v_j(t_k^-)|$, where $j \in \{1, 2, \dots, n\}$. When $t \in (t_k, t_{k+1})$, we can estimate $x(t)$ by letting $\hat{x}(t)$ evolve according to (3.3.10c); at $t = t_k$, a measurement y_{j_k} (based on a TOD-like protocol) is sent to the remote estimator and provides feedback impulse control to the estimate \hat{x}_{j_k} . The objective is to achieve ISS/iISS properties of the estimation error $E(t)$, which is defined by $E(t) = \hat{x}(t) - x(t)$ and can be shown to satisfy the following impulsive and switching hybrid delayed systems

$$\begin{cases} E'(t) = A_{i_k}E(t) + \hat{f}_{i_k}(\hat{x}(t)) - f_{i_k}(x(t)) - B_{i_k}w(t), & t \in (t_k, t_{k+1}), \\ \hat{E}_l(t) = \begin{cases} v_{j_k}(t^-), & l = j_k, \\ \hat{E}_l(t^-), & l \neq j_k, \end{cases} & l \in \{1, 2, \dots, n\}. \end{cases} \quad (3.3.11a)$$

$$(3.3.11b)$$

It is assumed that there exist positive constants L_i ($i \in \mathcal{I}$) such that

$$|f_i(x) - \hat{f}_i(\hat{x})| \leq L_i |x - \hat{x}|, \quad \forall x, \hat{x} \in \mathcal{R}^n, \quad i \in \mathcal{I}. \quad (3.3.12)$$

Let $h_0 = h = |x|$. To investigate the (h_0, h) -ISS properties of (3.3.11), choose a (common) Lyapunov function $V_i(t, E) = V(t, E) = x^2$ for $(t, E) \in \mathcal{R}^+ \times \mathcal{R}^n$. Similar to [67], for each ρ in $((n-1)/n, 1)$, one can show that there exists a function $\chi \in \mathcal{K}_\infty$ such that

$$V(t, E(t)) \leq \rho V(t^-, E(t^-)), \quad (3.3.13)$$

provided that $V(t^-, E(t^-)) \geq \chi(v(t^-))$. Therefore, condition (iii) of Theorem 3.3.1 is satisfied with $g(s) = \rho s$. Computing the upper right-hand derivative of $V(t, E)$ along the i th mode of (3.3.11) gives

$$\begin{aligned} D^+ V_i(t, E) &\leq 2E^T \left[A_i E + \hat{f}_i(\hat{x}(t)) - f_i(x(t)) - B_i w(t) \right] \\ &\leq \left[\lambda_{\max}(A_i^T + A_i) + L_i^2 + \varepsilon \right] V(t, E), \end{aligned} \quad (3.3.14)$$

provided that $V(t, E) \geq \chi_\varepsilon(|w(t)|)$, where $\varepsilon > 0$ is an arbitrary positive constant and χ_ε is a function in \mathcal{K}_∞ which depends on ε . We claim that

Proposition 3.3.1 *If*

$$\ln \left(\frac{n-1}{n} \right) < - \left[\lambda_{\max}(A_i^T + A_i) + L_i^2 \right] \tau_i < 0, \quad (3.3.15)$$

then the error system (3.3.11) is uniformly (h_0, h) -ISS over $\bigcap_{i \in \mathcal{I}} \mathcal{S}_{\text{sup}}^i(\delta_i)$. In particular, for $\delta = \min_{i \in \mathcal{I}} \delta_i > 0$, system (3.3.11) is uniformly (h_0, h) -ISS over $\mathcal{S}_{\text{sup}}(\delta)$.

Actually, if (3.3.15) holds, one can choose $\rho \in ((n-1)/n, 1)$ and $\mu_i > \lambda_{\max}(A_i^T + A_i) + L_i^2 > 0$ such that $\ln \rho < -\mu_i \delta_i$. In view of (3.3.14), we can choose $\varepsilon > 0$ sufficiently small such that condition (ii) of Theorem 3.3.1 is satisfied with $p_i(s) \equiv \mu_i$ and $c_i(s) = s$. Condition (iv) of Theorem 3.3.1 now reads

$$\tau_i \mu_i = N_i > M_i = \sup_{q>0} \int_{\rho q}^q \frac{1}{s} ds = -\ln \rho.$$

Our claim follows from the conclusion of Theorem 3.3.1.

As a numerical example, we take $B_i = [1 \quad 0.1 \quad 0]$,

$$f_i(x) = \hat{f}_i(x) = [\alpha_i(a-b) \quad 0 \quad 0]^T \text{sat}(x_1),$$

and

$$A_i = \begin{bmatrix} -\alpha_i(1-b) & \alpha_i & 0 \\ 1 & -1 & 1 \\ 0 & -\beta_i & 0 \end{bmatrix},$$

where $i \in \mathcal{I} = \{1, 2\}$, and $\alpha_1 = 9$, $\beta_1 = 100/7$, $\alpha_2 = 10$, $\beta_2 = 16$, $a = 8/7$, $b = 5/7$. Therefore, the state system can be regarded as a hybrid system switching between two delayed Chua's circuits with slightly different parameters, both of which exhibit chaotic behaviors under the given parameters. It is easy to verify that (3.3.12) is satisfied with $L_1 = 27/7$ and $L_2 = 30/7$. Moreover,

$$\lambda_{\max}(A_1^T + A_1) = 14.8685, \quad \lambda_{\max}(A_2^T + A_2) = 16.7839.$$

With $n = 3$, (3.3.15) reduces to

$$\delta_1 < 0.01363, \quad \delta_2 < 0.01153.$$

Therefore, with $\delta_1 = 0.014$ and $\delta = 0.012$, Theorem 3.3.2 guarantees that the error system (3.3.11) is uniformly (h_0, h) -ISS over $\bigcap_{i=1,2} \mathcal{S}_{\text{sup}}^i(\delta_i)$. In particular, for $\delta = 0.012$, system (3.3.11) is uniformly ISS over $\mathcal{S}_{\text{sup}}(\delta)$. \square

3.4 Summary

In this chapter, we have considered hybrid systems with both impulse and switching characteristics. The hybrid system is formulated as an impulsive switched system.

In Section 3.2, an invariance principle is established for impulsive switched systems, which generalizes the classical LaSalle's principle to the general hybrid setting of impulsive switched systems under weak dwell-time signals. Asymptotic stability results for impulsive switched systems under weak dwell-time impulsive and switching signals are derived as important applications of the invariance principle. Several examples have been presented to illustrate the main results, which showed that the invariance principle established here, specialized to the switched system framework, still considerably improves those in the literature. The stability criteria are then applied to study a switched SEIR model with pulse treatment as an application.

In Section 3.3, we have established sufficient conditions for the input-to-state stability and of hybrid systems with both switching and impulse effects. The main results are established through two class- \mathcal{KL} estimates for impulsive systems. The results given by Theorem 3.3.1 and Theorem 3.3.2 are quite general in view of the stability analysis perform in terms of two measures as well as the fact that the differential inequalities satisfied by the Lyapunov functions can be highly nonlinear.

C H A P T E R

4

Hybrid Systems with Time-Delay

As introduced in Chapter 1, time-delay is inevitable in many applications, that is, the future state of the system depends not only on the present state but also on the past states. The ubiquitous nature of time-delay makes time-delay systems (or functional differential equations) more appropriate models to describe practical processes. In this chapter, we will present a mathematical formulation of hybrid systems with time-delay and partially extend the qualitative results obtained in Chapters 2 and 3 for ordinary hybrid systems to hybrid time-delay systems.

4.1 Mathematical Formulation

4.1.1 Switched Delay Systems

Given $r \geq 0$, let $\mathcal{C} := C([-r, 0]; \mathcal{R}^n)$ denote the space of continuous functions with domain $[-r, 0]$ and range in \mathcal{R}^n . The norm in this space is defined by $\|\phi\| = \max_{-r \leq \theta \leq 0} |\phi(\theta)|$ for ϕ in \mathcal{C} . Suppose x is a function from \mathcal{R} to \mathcal{R}^n . For any $t \in \mathcal{R}$, let x_t be an element of \mathcal{C} defined by $x_t(\theta) = x(t + \theta)$, $-r \leq \theta \leq 0$.

A *switched delay system* can be written as

$$\dot{x} = f_\sigma(x_t), \quad t \geq 0, \quad \sigma \in \mathcal{S}, \quad (4.1.1)$$

where σ is a switching signal from \mathcal{R}^+ to \mathcal{I} , $\{f_i : i \in \mathcal{I}\}$ is a family of functionals from \mathcal{C} to \mathcal{R}^n , and \mathcal{S} denotes a certain admissible set of switching signals. As in Chapter 2, if the switching times are explicitly considered, they are denoted by $\{t_k : k \in \mathcal{Z}^+\}$.

Definition 4.1.1 For a switching signal $\sigma \in \mathcal{S}$ and a function $\phi \in \mathcal{C}$, we say that a function $x(t)$ from $[-r, \infty)$ to \mathcal{R}^n is a **solution** of (4.1.1) with initial condition $\phi \in \mathcal{C}$ and switching signal $\sigma \in \mathcal{S}$, if $x(t)$ is continuous and satisfies

$$\dot{x}(t) = f_{\sigma(t)}(x_t), \quad t \geq 0, \quad x_0 = \phi, \quad (4.1.2)$$

where \dot{x} denotes the right-hand derivative of x . \square

To emphasize the initial function ϕ and the switching signal σ , the solution can be written as $x(\phi, \sigma)$. To guarantee that (4.1.1) has a local solution for any $\phi \in \mathcal{C}$ and $\sigma \in \mathcal{S}$, it is assumed that the functionals $\{f_p : p \in \mathcal{P}\}$ are continuous and map bounded sets into bounded sets. We may also, without ambiguity, write the solution as $x(\phi)$ or x , if the switching signal σ and the initial condition are not emphasized.

Remark 4.1.1 It is easy to see that the functional differential equation (4.1.2) is equivalent to the integral equation

$$x(t) = \phi(0) + \int_0^t f_{\sigma(s)}(x_s) ds, \quad t \geq 0.$$

Since $f_{\sigma(t)}(x_t)$ remains continuous on $\mathcal{R}^+ \setminus \{t_k : k \in \mathcal{Z}^+\}$, we can see that the solution $x(t)$ is continuously differentiable on $\mathcal{R}^+ \setminus \{t_k : k \in \mathcal{Z}^+\}$, although only right-hand derivative is involved in the original equation (4.1.1). \square

In Section 4.2, we will establish an invariance principle for system (4.1.1) and apply the invariance principle to obtain several stability and instability tests for switched delay systems.

4.1.2 General Hybrid Systems with Time-Delay

We can build a more sophisticated hybrid system model based on system (4.1.1) by considering time-varying (non-autonomous) structures, impulses effects, and external inputs.

To formulate a delay systems with impulse effects, we need a few more notation. For $-\infty < a < b < \infty$, we use the notation $\mathcal{PC}([a, b]; \mathcal{R}^n)$ to denote the class of **piecewise continuous** functions from $[a, b]$ to \mathcal{R}^n satisfying the following: (i) it has at most a finite number of jump discontinuities on (a, b) , i.e., points at which the function has finite-valued but different left-hand and right-hand limits; (ii) it is continuous from the right at all points in $[a, b)$. We say that a function $\psi : [a, \infty) \rightarrow \mathcal{R}^n$ belongs to the class

$\mathcal{PC}([a, \infty); \mathcal{R}^n)$, if $\psi|_{[a,b]}$ (ψ restricted on $[a, b]$) is in $\mathcal{PC}([a, b]; \mathcal{R}^n)$ for all $b > a$. Given $r > 0$, a norm on $\mathcal{PC}([-r, 0]; \mathcal{R}^n)$ is defined as $\|\phi\| := \sup_{-r \leq s \leq 0} |\phi(s)|$ for $\phi \in \mathcal{PC}([-r, 0]; \mathcal{R}^n)$. For simplicity, \mathcal{PC} is used for $\mathcal{PC}([-r, 0]; \mathcal{R}^n)$ if r is known and fixed. Given $x \in \mathcal{PC}([-r, \infty); \mathcal{R}^n)$ and for each $t \in \mathcal{R}^+$, let x_t be an element of \mathcal{PC} defined by $x_t(s) := x(t + s)$, $-r \leq s \leq 0$.

Let $\{(t_k, i_k, j_k)\}$ be a given impulsive switching signal associated with two index sets \mathcal{I} and \mathcal{J} . Consider the following impulsive switched delay system:

$$\begin{cases} x'(t) = f_{i_k}(t, x_t, w(t)), & t \in (t_k, t_{k+1}), & (4.1.3a) \\ \Delta x(t) = I_{j_k}(t, x_{t^-}, w(t^-)), & t = t_k, & (4.1.3b) \\ x_{t_0} = \xi, & & (4.1.3c) \end{cases}$$

where $\xi \in \mathcal{PC}$ is the initial data, $w(t) : \mathcal{R}^+ \rightarrow \mathcal{R}^m$ is an input function assumed to be in $\mathcal{PC}(\mathcal{R}^+; \mathcal{R}^m)$, and x_{t^-} is defined by $x_{t^-}(s) = x(t + s)$, for $s \in [-r, 0)$, and $x_{t^-}(0) = x(t^-)$, where $x(t^-) = \lim_{s \rightarrow t^-} x(s)$ (similarly, $w(t^-) = \lim_{s \rightarrow t^-} w(s)$). For each $i \in \mathcal{I}$ and $j \in \mathcal{J}$, $f_i : \mathcal{R}^+ \times \mathcal{PC} \times \mathcal{R}^m \rightarrow \mathcal{R}^n$ and $I_j : \mathcal{R}^+ \times \mathcal{PC} \times \mathcal{R}^m \rightarrow \mathcal{R}^n$. The input function w is assumed to be in $\mathcal{PC}(\mathcal{R}^+; \mathcal{R}^m)$. Given $w \in \mathcal{PC}(\mathcal{R}^+; \mathcal{R}^m)$ and $i \in \mathcal{I}$, define $g_i(t, \phi) = f_i(t, \phi, w(t))$ and suppose that $g_i : \mathcal{R}^+ \times \mathcal{PC} \rightarrow \mathcal{R}^n$ is composite-PC (i.e., for any function $x \in \mathcal{PC}([-r, \infty); \mathcal{R}^n)$, the composite function $t \rightarrow g_i(t, x_t)$ is in $\mathcal{PC}(\mathcal{R}^+; \mathcal{R}^n)$), quasi-bounded, and continuous in its second variable so that system (4.1.3) has at least one solution (see [9]¹). Moreover, each solution x belongs to the space $\mathcal{PC}([t_0 - r, \infty); \mathcal{R}^n)$ and is continuous at each $t \neq t_k$ for $t \geq t_0$.

In Section 4.3, we will focus on the input-to-state stability analysis of system (4.1.3) by using the method of multiple Lyapunov functionals.

4.2 Invariance Principles for Switched Delay Systems

Since the classical LaSalle's invariance principle (see, e.g., [101], [102]) has been proved to be a powerful tool for the stability analysis of autonomous ordinary differential equations, extensions of the original invariance principle have been derived for delay differential equations. In the 1960's, [63] established invariance principle for functional differential equations, in which Lyapunov functionals were employed to discuss the extensions of

¹In [9], the existence and uniqueness results are established for impulsive delay systems without switching. The case for system (4.1.3) with switching is essentially the same, by an argument using the method of steps over all the switching/impulse intervals.

LaSalle's invariance principles. In the 1980's, [60] extended the work of [63] and established an invariance principle using Lyapunov-Razumikhin functions. Later, results in [63] and [59] have been extended to neutral-type delay equations in [39] and [60], respectively. On the other hand, as introduced in Section 3.2 of Chapter 3, several invariance principles for switched systems are derived by various authors in recent years. Particular, in Section 3.2, we have established an invariance principle for impulsive switched systems and showed that the invariance principle obtained can be useful in providing stability criteria for general impulsive switched systems as well as in investigating practical systems.

Stability analysis of switched delay systems has attracted many researchers from various fields, and stability criteria or stabilizing controllers have been obtained using techniques combining the classical Lyapunov functional method for functional differential equations and the new average dwell-time (or dwell-time) scheme for switched ordinary systems (see, e.g., [1], [91], [92], [109], [179], [186], [194], [200]). In contrast, the idea of invariance-like principles for switched delay systems has not yet been addressed and explored in the literature.

In this section, we will extend LaSalle's invariance principles to the switched delay system described by (4.1.1). By introducing the notions of weak τ -invariance, τ -persistent mode, and τ -persistent limit function, where $\tau > 0$ is a weak dwell-time for the class of switching signals considered in this section, both results of [60] and [63] are generalized to switched delay systems with weak dwell-time switchings. Invariance principles under weak dwell-time conditions for switched delay systems are established using both multiple Lyapunov functionals and multiple Lyapunov-Razumikhin functions. Several stability and instability criteria under weak dwell-time conditions for switched delay systems are then derived, as important applications of the invariance principles obtained.

The rest of this section is organized as follows. Section 4.2.1 presents the preliminary definitions and lemmas that are essential to prove weak invariance principles for switched delay systems under weak dwell-time conditions. Section 4.2.2 is devoted to prove a weak invariance principle using multiple Lyapunov functionals. Section 4.2.3 applies the weak invariance principle to derive asymptotic stability criteria for switched delay systems, and Section 4.2.4 shows an instability test for switched delay systems based on the invariance principle obtained. Section 4.2.5 shows results parallel to those of Sections 4.2.2–4.2.4, now using multiple Lyapunov-Razumikhin functions. Section 4.2.6 presents applications of the main results by several examples.

4.2.1 Preliminary Results

In this section, we formulate some preliminaries which are necessary to establish weak invariance principles along the lines of [63] and [101], as well as [4] and [136]. Especially, the notions of τ -persistent mode, τ -persistent limit, and weak τ -invariance are introduced for switched delay systems and some preliminary results are established.

Definition 4.2.1 Assume that $f_i(0) = 0$ for all $i \in \mathcal{I}$ such that $x = 0$ is a trivial solution of system (4.1.1) for any $\sigma \in \mathcal{S}$. The trivial solution of (4.1.1) is said to be

(\mathcal{S}_1) **stable** (with respect to \mathcal{S}) if, for each $\varepsilon > 0$, there exists a $\delta = \delta(\varepsilon) > 0$ such that $\|\phi\| < \delta$ implies that, for all $\sigma \in \mathcal{S}$, $x(\phi, \sigma)(t)$ exists and $|x(\phi, \sigma)(t)| < \varepsilon$ for all $t \geq 0$;

(\mathcal{S}_2) **asymptotically stable** (with respect to \mathcal{S}) if (\mathcal{S}_1) is satisfied and there exists a $\rho > 0$ such that $\|\phi\| < \rho$ implies $x(\phi, \sigma)(t) \rightarrow 0$ as $t \rightarrow \infty$;

(\mathcal{S}_3) **globally asymptotically stable** (with respect to \mathcal{S}) if (\mathcal{S}_2) is satisfied with an arbitrary $\rho > 0$;

(\mathcal{S}_4) **unstable** (with respect to \mathcal{S}) if (\mathcal{S}_1) fails. □

Definition 4.2.2 A function χ is said to be a **solution** of the i th subsystem of (4.1.1) (or (4.1.1. i)), for some $i \in \mathcal{I}$, on an interval $[\alpha, \beta]$, if χ is defined on $[\alpha - r, \beta]$ and satisfies

(i) χ is continuous on $[\alpha - r, \beta]$;

(ii) χ is differentiable on $[\alpha, \beta]$ (for the end points α and β , only one-side derivatives are required to exist); and

(iii) χ satisfies $\dot{\chi}(t) = f_i(\chi_t)$ for all $t \in [\alpha, \beta]$. □

Definition 4.2.3 Let V be a continuous functional from \mathcal{C} to \mathcal{R} , ϕ a function in \mathcal{C} , and χ a solution piece of (4.1.1. i) on $[\alpha, \beta]$, with $\alpha \leq 0 \leq \beta$ and $\beta - \alpha > 0$, and $\chi_0 = \phi$. If $\beta > 0$, define the upper right-hand derivative of V with respect to the i th mode of (4.1.1) to be

$$D^+ V_i(\phi) = \limsup_{h \rightarrow 0^+} \frac{1}{h} [V(\chi_h(\phi)) - V(\phi)]. \quad (4.2.1)$$

If $\alpha < 0$, define the upper left-hand derivative of V with respect to the i th mode of (4.1.1) to be

$$D^- V_i(\phi) = \limsup_{h \rightarrow 0^-} \frac{1}{h} [V(\chi_h(\phi)) - V(\phi)]. \quad (4.2.2)$$

□

The following proposition gives an alternative way to evaluate $D^+ V_i$ and $D^- V_i$ without explicit reference to solutions, provided that the functional V is locally Lipschitz, i.e., V is Lipschitz continuous on each compact set of \mathcal{C} .

Proposition 4.2.1 *If V is a locally Lipschitz continuous functional from \mathcal{C} to \mathcal{R} , then*

$$D^+ V_i(\phi) = \limsup_{h \rightarrow 0^+} \frac{1}{h} [V(\phi_{[h]}^i) - V(\phi)], \quad (4.2.3)$$

$$D^- V_i(\phi) = \limsup_{h \rightarrow 0^-} \frac{1}{h} [V(\phi_{[h]}^i) - V(\phi)], \quad (4.2.4)$$

where $\phi_{[h]}^i$ is defined as follows:

(1) for $r > h > 0$,

$$\phi_{[h]}^i(s) = \begin{cases} \phi(s+h), & s \in [-r, -h], \\ \phi(0) + (s+h)f_i(\phi), & s \in (-h, 0]. \end{cases} \quad (4.2.5)$$

(2) for $-r < h < 0$,

$$\phi_{[h]}^i(s) = \begin{cases} \phi(s+h), & s \in [-r-h, 0], \\ \phi(-r) + (s+r+h)f_i(\phi), & s \in [-r, -r-h]. \end{cases} \quad (4.2.6)$$

Proof. See [8, p. 53] for the proof for (4.2.3). The proof for (4.2.4) is similar. \square

Definition 4.2.4 A family of functionals $\{V_i : i \in \mathcal{I}\}$ are called **multiple Lyapunov functionals** (MLFs) for system (4.1.1) on a set $G \subset \mathcal{C}$, if V_i is continuous on \overline{G} , the closure of G , and $D^+ V_i(\phi) \leq 0$ for all $\phi \in G$ and $i \in \mathcal{I}$. \square

The following assumption imposes a condition on the evolution of the functionals along a solution at switching instants, which serves the same purpose as Assumption 3.2.1 in proving invariance principle for impulsive switched systems in Section 3.2 of Chapter 3. A weaker version is stated here, which only stipulates conditions on a single functional V_i .

Assumption 4.2.1 For some $i \in \mathcal{I}$ and every pair of switching instants $t_j < t_k$ such that $\sigma(t_j) = \sigma(t_k) = i$, we have

$$V_i(x_{t_k}(\phi, \sigma)) \leq V_i(x_{t_{j+1}}(\phi, \sigma)). \quad \square$$

Remark 4.2.1 In other words, if Assumption 4.2.1 is satisfied for some $i \in \mathcal{I}$, then the value of V_i at the beginning of each interval on which $\sigma = i$ does not exceed the value of V_i at the end of previous such intervals (if one exists). This condition, together with the fact that $\{V_i : i \in \mathcal{I}\}$ is a family of MLFs for system (4.1.1), ensures that $V_i(x_t(\phi))$ is nonincreasing on the union of all the intervals where the i th subsystem is activated. \square

Remark 4.2.2 It should be remarked that Assumption 4.2.1 imposes conditions on the switching signal σ (hence \mathcal{S}), the initial condition ϕ , and the solution x as a whole. As mentioned in [69], in hybrid control systems, the switching signal is often generated by a supervisory logic that guarantees, by construction, that assumptions such as Assumption 4.2.1 hold. \square

Remark 4.2.3 Assumption 4.2.1 is trivially satisfied in the case of a common Lyapunov functional (CLF), i.e., the family $\{V_i : i \in \mathcal{I}\}$ are identical for all $i \in \mathcal{I}$. \square

Following the treatment in Section 3.2 for impulsive switched systems, we propose only a rather mild condition, i.e., the weak dwell-time condition as formulated in Definition 3.1.3, on the switching signals. Let $\mathcal{S}_{\text{weak}}(\tau)$ denote the set of all switching signals with weak dwell-time τ , and let $\mathcal{S}_{\text{weak}}^i(\tau)$ denote the set of switching signals with weak dwell-time τ and $i \in \mathcal{I}$ as a persistent mode. Clearly, $\mathcal{S}_{\text{weak}}(\tau) = \bigcup_{i \in \mathcal{I}} \mathcal{S}_{\text{weak}}^i(\tau)$. For $\sigma \in \mathcal{S}_{\text{weak}}^i(\tau)$, we call i a **τ -persistent mode** of σ to emphasize the weak dwell-time τ , which is of particular interest for delay systems as will be demonstrated later in this Section.

For $\phi \in \mathcal{C}$ and $\sigma \in \mathcal{S}_{\text{weak}}(\tau)$, let $x(\phi, \sigma)$ be a solution of system (4.1.1) with initial condition ϕ and switching signal σ . The following definitions and lemmas are related to this specific solution $x(\phi, \sigma)$.

Definition 4.2.5 Given some $i \in \mathcal{I}$, an element ψ of \mathcal{C} is called a **τ -persistent limit function** of $x(\phi, \sigma)$ in the i th mode, if i is a τ -persistent mode of σ , with \mathcal{D}_i as the corresponding τ -persistent domain, and there exists a sequence of $s_n \in \mathcal{D}_i$, with $s_n \rightarrow \infty$ as $n \rightarrow \infty$, such that $x_{s_n}(\phi, \sigma) \rightarrow \psi$ as $n \rightarrow \infty$. The set of all such functions in \mathcal{C} is called the **τ -persistent limit set** of $x(\phi, \sigma)$ in the i th mode and is denoted by $\omega_i(x(\phi, \sigma))$. \square

Definition 4.2.6 For some $\tau > 0$, a set $M \subset \mathcal{C}$ is called a **weakly τ -invariant set** with respect to the i th mode of (4.1.1), if, for any ψ in M , there exists a solution piece χ of (4.1.1.i) on $[\alpha, \beta]$, with $\alpha \leq 0 \leq \beta$ and $\beta - \alpha \geq \tau$, such that $\chi_0 = \psi$ and $\chi_t \in M$ for all $t \in [\alpha, \beta]$. \square

Definition 4.2.7 The solution $x(\phi, \sigma)$ is said to *weakly approach* a set $M \subset \mathcal{C}$ in the i th mode as $t \rightarrow \infty$, if the i is a τ -persistent mode of σ and

$$\lim_{\substack{t \rightarrow \infty \\ t \in \mathcal{D}_i}} \text{dist}(x_t(\phi, \sigma), M) = 0,$$

where $\text{dist}(\psi, M)$ for $\psi \in \mathcal{C}$ is defined by $\text{dist}(\psi, M) = \inf_{\chi \in M} \|\psi - \chi\|$. \square

Clearly, the above definitions extend Definitions 3.2.4–3.2.6 from \mathcal{R}^n to \mathcal{C} .

Lemma 4.2.1 *If $i \in \mathcal{I}$ is a τ -persistent mode of σ , \mathcal{D}_i is the corresponding τ -persistent domain, and the solution $x(\phi, \sigma)$ is bounded in the i th, i.e., there exists a positive real number b such that $\|x_t(\phi, \sigma)\| \leq b$ for all $t \in \mathcal{D}_i$, then the family of functions $\{x_t(\phi, \sigma) : t \in \mathcal{D}_i, t \geq r\}$ belongs to a compact subset of \mathcal{C} .*

Proof. Define

$$\mathcal{B} := \{\psi \in \mathcal{C} : \|\psi\| \leq b, \|\dot{\psi}\| \leq b'\},$$

where b is the bound specified in the Lemma condition and b' is a positive real number such that f_i maps the bounded set $\{\psi \in \mathcal{C} : \|\psi\| \leq b\}$ into the bounded set $\{x \in \mathcal{R}^n : |x| \leq b'\}$ for all $i \in \mathcal{I}$. It is clear that the family $\{x_t(\phi, \sigma) : t \in \mathcal{D}_i, t \geq r\}$ is contained in \mathcal{B} . Moreover, by Arzela-Ascoli's compactness criterion, \mathcal{B} is a compact subset of \mathcal{C} . \square

Lemma 4.2.2 *If $i \in \mathcal{I}$ is a τ -persistent mode of σ and the solution $x(\phi, \sigma)$ is bounded in the i th mode, then $\omega_i(x(\phi, \sigma))$ is a nonempty, compact, and weakly τ -invariant set with respect to the i th mode of (4.1.1). Moreover, $x(\phi, \sigma)$ weakly approaches $\omega_i(x(\phi, \sigma))$ in the i th mode as $t \rightarrow \infty$.*

Proof. From Lemma 4.2.1, the family of functions $\{x_t(\phi, \sigma) : t \in \mathcal{D}_i, t \geq r\}$ belongs to a compact subset \mathcal{B} of \mathcal{C} and \mathcal{B} could be defined as in the proof of Lemma 4.2.1. Since i is a persistent mode, there must be a sequence $\{s_n\}$ in \mathcal{D}_i such that $x_{s_n}(\phi, \sigma)$ has a limit in \mathcal{B} . This shows that $\omega_i(x(\phi, \sigma))$ is not empty. Clearly, $\omega_i(x(\phi, \sigma))$ is a subset of the compact set \mathcal{B} . Thus to show that $\omega_i(x(\phi, \sigma))$ is compact, it suffices to show that $\omega_i(x(\phi, \sigma))$ is closed.

To show that $\omega_i(x(\phi, \sigma))$ is closed, suppose $\psi_n \in \omega_i(x(\phi, \sigma))$ approaches ψ as $n \rightarrow \infty$. Since $\psi_n \in \omega_i(x(\phi, \sigma))$ for each n , by Definition 4.2.5, one can choose $s_n \in \mathcal{D}_i$ large enough such that $\|x_{s_n}(\phi, \sigma) - \psi_n\| < 1/n$, for each n . Now given any $\varepsilon > 0$, choose n sufficiently large such that $\|\psi_n - \psi\| < \varepsilon/2$ and $\|x_{s_n}(\phi, \sigma) - \psi_n\| < \varepsilon/2$. Then $\|x_{s_n}(\phi, \sigma) - \psi\| < \varepsilon$

for n large enough, which shows $\psi \in \omega_i(x(\phi, \sigma))$ and therefore $\omega_i(x(\phi, \sigma))$ is closed. It follows that $\omega_i(x(\phi, \sigma))$ is compact.

The last assertion of the lemma can be shown by contradiction. Suppose that there exists an increasing sequence of $s_n \in \mathcal{D}_i$, with $s_n \rightarrow \infty$ as $n \rightarrow \infty$, and a $\delta > 0$ such that $\|x_{s_n}(\phi, \sigma) - \psi\| \geq \delta$ for all $\psi \in \omega_i(x(\phi, \sigma))$. Now since $x_{s_n}(\phi, \sigma)$ belongs to \mathcal{B} , which is compact, there must exist a subsequence of $x_{s_n}(\phi, \sigma)$ which converges to some $\psi \in \omega_i(x(\phi, \sigma))$. This contradicts with the inequality above and hence the last assertion of the lemma holds.

Finally, we show that $\omega_i(x(\phi, \sigma))$ is weakly τ -invariant with respect to the i th mode of (4.1.1), i.e., for any ψ in $\omega_i(x(\phi, \sigma))$, there exists a solution piece χ of (4.1.1.i) on $[\alpha - r, \beta]$, with $\alpha \leq 0 \leq \beta$ and $\beta - \alpha \geq \tau$, such that $\chi_0 = \psi$ and $\chi_t \in \omega_i(x(\phi, \sigma)), \forall t \in [\alpha, \beta]$.

Since $\psi \in \omega_i(x(\phi, \sigma))$, there exists an increasing sequence of $s_n \in \mathcal{D}_i$ such that $s_n \rightarrow \infty$ and $x_{s_n}(\phi, \sigma) \rightarrow \psi$ as $n \rightarrow \infty$. Moreover, we can pick s_n so that there exists a sequence of intervals $[\tau_{2n-1}, \tau_{2n}]$ which verifies that, for all $n, s_n \in [\tau_{2n-1}, \tau_{2n}] \subset \mathcal{D}_i$. By this choice, $x(\phi, \sigma)$ satisfies the i th subsystem on $[\tau_{2n-1}, \tau_{2n}]$, i.e.,

$$\dot{x}(\phi, \sigma)(t) = f_i(x_t(\phi, \sigma)), \quad \forall t \in [\tau_{2n-1}, \tau_{2n}].$$

Moreover, $x(\phi, \sigma)(t)$ is continuously differentiable on $[\tau_{2n-1}, \tau_{2n}]$ and continuous on $[\tau_{2n-1} - r, \tau_{2n}]$, according to Remark 4.1.1. Putting

$$\alpha_n = \tau_{2n-1} - s_n \quad \text{and} \quad \beta_n = \tau_{2n} - s_n, \quad (4.2.7)$$

then $\beta_n - \alpha_n \geq \tau$ and $\alpha_n \leq 0 \leq \beta_n$. Define a sequence of functions χ^n as

$$\chi^n(t) := x(\phi, \sigma)(t + s_n), \quad t \in [\alpha_n - r, \beta_n].$$

It follows that χ_n satisfies

$$\dot{\chi}^n(t) = f_i(\chi_t^n), \quad \chi_t^n = x_{t+s_n}(\phi), \quad \forall t \in [\alpha_n, \beta_n]. \quad (4.2.8)$$

It is clear that χ^n is continuously differentiable on $[\alpha_n, \beta_n]$ and continuous on $[\alpha_n - r, \beta_n]$.

To show convergence of (some subsequence of) χ^n , we need to consider χ^n as a sequence of functions defined on a common interval $[\alpha - r, \beta]$. Moreover, to show weak τ -invariance, we require $\beta - \alpha \geq \tau$ and $\alpha \leq 0 \leq \beta$. Consider two cases.

Case (i) If either $\limsup_{n \rightarrow \infty} \beta_n = \infty$ or $\liminf_{n \rightarrow \infty} \alpha_n = -\infty$, we can choose $[\alpha, \beta] = [0, \tau]$ or $[\alpha, \beta] = [-\tau, 0]$, respectively, and an appropriate subsequence of χ^n , which we can

keep the same designation, such that (4.2.8) is satisfied on $[\alpha, \beta]$, while χ^n is defined and continuous on $[\alpha - r, \beta]$, and continuously differentiable on $[\alpha, \beta]$. It is clear that $\beta - \alpha \geq \tau$ and $\alpha \leq 0 \leq \beta$.

Case (ii) If both α_n and β_n are bounded sequences. Choose subsequences of α_n and β_n , with the same designation, such that $\alpha_n \rightarrow \alpha$ and $\beta_n \rightarrow \beta$, as $n \rightarrow \infty$. It is clear that $\beta - \alpha \geq \tau$ and $\alpha \leq 0 \leq \beta$. However, $[\alpha - r, \beta]$ might not be a common subinterval of $[\alpha_n - r, \beta_n]$. We need to extend χ^n to $[\alpha, \beta]$, if $[\alpha - r, \beta] \not\subset [\alpha_n - r, \beta_n]$ for some n . If $\alpha < \alpha_n$, define

$$\chi^n(t) := \chi^n(\alpha_n - r), \quad t \in [\alpha - r, \alpha_n - r].$$

If $\beta > \beta_n$, define

$$\chi^n(t) := \chi^n(\beta_n), \quad t \in (\beta_n, \beta].$$

Note that (4.2.8) is only guaranteed for $t \in [\alpha_n, \beta_n]$, even if χ^n is now defined on $[\alpha - r, \beta]$ for all n . However, we do have $\alpha_n \rightarrow \alpha$ and $\beta_n \rightarrow \beta$, as $n \rightarrow \infty$.

In both cases, what we have obtained is a sequence of functions χ^n defined on a common interval $[\alpha - r, \beta]$, with $\beta - \alpha \geq \tau$ and $\alpha \leq 0 \leq \beta$.

We proceed to show that χ^n , as a sequence of functions defined on $[\alpha - r, \beta]$, has a subsequence that uniformly converges to a function χ on $[\alpha - r, \beta]$. Since $x_t(\phi, \sigma)$ is bounded by some $b > 0$ for all $t \geq 0$, it follows that χ^n is uniformly bounded by b on $[\alpha - r, \beta]$. Moreover, still let b' be the positive real number such that f_i maps the bounded set $\{\psi \in \mathcal{C} : \|\psi\| \leq b\}$ into the bounded set $\{x \in \mathcal{R}^n : |x| \leq b'\}$ for each $i \in \mathcal{I}$. Define

$$\mathcal{B}' := \{\psi \in C([\alpha - r, \beta]; \mathcal{R}^n) : \|\psi\| \leq b, \|\dot{\psi}\| \leq b'\},$$

where $C([\alpha - r, \beta]; \mathcal{R}^n)$ denotes the space of continuous functions with domain $[\alpha - r, \beta]$ and range in \mathcal{R}^n . By Arzela-Ascoli's compactness criterion, \mathcal{B}' is a compact set. It is clear that, for both cases, the sequence of χ^n belongs to \mathcal{B}' and therefore χ^n has a subsequence, still designated by χ^n , converges to some function, say χ , on $[\alpha - r, \beta]$ in the uniform norm. Hence χ is continuous on $[\alpha - r, \beta]$. Moreover, for each $t \in (\alpha, \beta)$, we have $\dot{\chi}(t) = f_i(\chi_t)$ (note that, in the second case, $t \in (\alpha, \beta)$ implies that $t \in (\alpha_n, \beta_n)$ for n sufficiently large). Since $\dot{\chi}(t) = f_i(\chi_t)$ is uniformly continuous on (α, β) , we have that $\lim_{t \rightarrow \alpha^+} \dot{\chi}(t)$ and $\lim_{t \rightarrow \beta^-} \dot{\chi}(t)$ exist and equal $\dot{\chi}(\alpha^+)$ and $\dot{\chi}(\beta^-)$ (the right-hand derivative at $t = \alpha$ and left-hand derivative at $t = \beta$), respectively. Hence, by continuity, $\dot{\chi}(t) = f_i(\chi_t)$ for all $t \in [\alpha, \beta]$, and χ is a solution piece of (4.1.1.i) on $[\alpha, \beta]$. Moreover, $\chi_0 = \lim_{n \rightarrow \infty} \chi_0^n =$

$\lim_{n \rightarrow \infty} x_{s_n}(\phi, \sigma) = \psi$. Finally, we have $\chi_t = \lim_{n \rightarrow \infty} \chi_t^n = \lim_{n \rightarrow \infty} x_{t+s_n}(\phi)$, for any fixed t in (α, β) . For a fixed $t \in (\alpha, \beta)$, put $s'_n = t + s_n$. According to (4.2.7) and the fact that $\alpha_n \rightarrow \alpha$ and $\beta_n \rightarrow \beta$, as $n \rightarrow \infty$, $s'_n \in [\tau_{2n-1}, \tau_{2n}]$ for n sufficiently large. Since $\sigma = i$ on $[\tau_{2n-1}, \tau_{2n}]$ and $\tau_{2n} - \tau_{2n-1} \geq \tau$, it follows that $\chi_t \in \omega_i(x(\phi, \sigma))$ for all $t \in (\alpha, \beta)$. Since $\omega_i(x(\phi, \sigma))$ is closed and χ_t is continuous on $[\alpha, \beta]$, χ_α and χ_β belong to $\omega_i(x(\phi, \sigma))$. Therefore, $\omega_i(x(\phi, \sigma))$ is shown to be weakly τ -invariant with respect to the i th mode of (4.1.1) and the proof is complete. \square

4.2.2 A Weak Invariance Principle

In this section, we apply MLFs to establish a weak invariance principle for switched delay systems.

Let $\{V_i : i \in \mathcal{I}\}$ be a family of MLFs for (4.1.1) on $G \subset \mathcal{C}$. For some $\tau > 0$, define E_i to be the set of all $\phi \in \overline{G}$ such that there exists a solution piece χ of (4.1.1.i) on some interval $[\alpha, \beta]$, with $\beta - \alpha > 0$ and $\alpha \leq 0 \leq \beta$, satisfying $\chi_0 = \phi$ and $V_i(\chi_t) \equiv c$, some constant, on $[\alpha, \beta]$. Let $M_i(\tau)$ be the largest set in E_i that is weakly τ -invariant with respect to the i th mode of (4.1.1).

Theorem 4.2.1 *Let $\{V_i : i \in \mathcal{I}\}$ be a family of MLFs for (4.1.1) on G , $x(\phi, \sigma)$ be a solution of (4.1.1) such that $x_t(\phi, \sigma)$ remains in G for $t \geq 0$, $i \in \mathcal{I}$ be a τ -persistent mode of σ , and $x(\phi, \sigma)$ is bounded in the i th mode. Suppose, in addition, Assumption 4.2.1 is satisfied for this i . Then $x(\phi, \sigma)$ weakly approaches $M_i(\tau) \cap V_i^{-1}(c)$, for some c , in the i th mode as $t \rightarrow \infty$.*

Proof. By Lemma 4.2.2, $x_t(\phi, \sigma)$ has a nonempty ω -limit set $\omega_i(x(\phi, \sigma))$. We proceed to show that $\omega_i(x(\phi, \sigma)) \subset E_i$. Let \mathcal{D}_i be the τ -persistent domain of the i th mode of σ . The conditions on V_i imply that $V_i(x_t(\phi, \sigma))$ is nonincreasing on \mathcal{D}_i . Moreover, $V_i(x_t(\phi, \sigma))$ is bounded from below on \mathcal{D}_i , since $\{x_t(\phi, \sigma) : t \in \mathcal{D}_i\}$ belongs to a compact set of \mathcal{C} according to Lemma 4.2.1. Therefore, as $t \rightarrow \infty$ in \mathcal{D}_i , $V_i(x_t(\phi, \sigma))$ yields a limit as

$$\lim_{\substack{t \rightarrow \infty \\ t \in \mathcal{D}_i}} V_i(x_t(\phi, \sigma)) = c.$$

For any $\psi \in \omega_i(x(\phi, \sigma))$, there exists a sequence $s_n \in \mathcal{D}_i$ such that $s_n \rightarrow \infty$ and $x_{s_n}(\phi, \sigma) \rightarrow \psi$ as $n \rightarrow \infty$. It follows by continuity of V_i that

$$V_i(\psi) = \lim_{n \rightarrow \infty} V_i(x_{s_n}(\phi, \sigma)) = \lim_{\substack{t \rightarrow \infty \\ t \in \mathcal{D}_i}} V_i(x_t(\phi, \sigma)) = c.$$

Hence, $V_i(\psi) = c$ for all $\psi \in \omega_i(x(\phi, \sigma))$ and $\omega_i(x(\phi, \sigma)) \subset V_i^{-1}(c)$. By Lemma 4.2.2, $\omega_i(x(\phi, \sigma))$ is weakly τ -invariant with respect to the i th mode of (4.1.1), i.e., for each $\psi \in \omega_i(x(\phi, \sigma))$, there exists a solution piece χ of (4.1.1.i) on some interval $[\alpha, \beta]$ with $\alpha \leq 0 \leq \beta$ and $\beta - \alpha \geq \tau$ such that $\chi_0 = \psi$ and $\chi_t \in \omega_i(x(\phi, \sigma))$ for all $t \in [\alpha, \beta]$. Therefore, $V_i(\chi_t) = c$ for all $t \in [\alpha, \beta]$. It follows that $\omega_i(x(\phi, \sigma)) \subset E_i$. By the definition of $M_i(\tau)$ and because $\omega_i(x(\phi, \sigma))$ is weakly τ -invariant with respect to the i th mode of (4.1.1), we have $\omega_i(x(\phi, \sigma)) \subset M_i(\tau) \subset E_i$. From lemma 4.2.2, $x(\phi, \sigma)$ weakly approaches $\omega_i(x(\phi, \sigma))$ in the i th mode and therefore it weakly approaches $M_i(\tau) \cap V_i^{-1}(c)$ in the i th mode. This completes the proof. \square

The definition we choose for E_i gives a more precise characterization of the set M_i . The following proposition sometimes gives a more convenient way for locating E_i (hence M_i).

Proposition 4.2.2 *For $\phi \in E_i$, we have either $D^+V_i(\phi) = 0$ or $D^-V_i(\phi) = 0$, i.e., E_i is a subset of*

$$E'_i := \{\phi \in \bar{G} : D^+V_i(\phi) = 0 \text{ or } D^-V_i(\phi) = 0\}.$$

4.2.3 Stability Criteria

Before we apply the invariance principle obtained in Theorem 4.2.1 to derive some stability results, we need to introduce a local stability result for switched delay systems by MLFs. In this section and later on, we use the notation \mathcal{B}_r to denote the set $\{\phi \in \mathcal{C} : \|\phi\| < r\}$ for any $r > 0$ and \mathcal{C}_0 the set $\{\phi \in \mathcal{C} : \phi(0) = 0\}$.

Proposition 4.2.3 *Suppose that*

(i) $\{V_i : i \in \mathcal{I}\}$ is a family of MLFs for (4.1.1) on \mathcal{B}_ρ for some $\rho > 0$ satisfying

$$u(|\phi(0)|) \leq V_i(\phi) \leq v(\|\phi\|), \quad \forall \phi \in \mathcal{B}_\rho, i \in \mathcal{I},$$

where u and v are of class \mathcal{K} ; and

(ii) Assumption 4.2.1 is satisfied for all $i \in \mathcal{I}$.

Then the trivial solution $x = 0$ of system (4.1.1) is stable.

Proof. Given any $\varepsilon \in (0, \rho)$, we let $\delta_0 = \varepsilon$ and define $\delta_1, \delta_2, \dots, \delta_N$ recursively such that $\delta_{j+1} < \delta_j$ and $v(\delta_{j+1}) < u(\delta_j)$ for $j = 0, 1, 2, \dots, N - 1$, where N is the cardinality of \mathcal{I} .

Stability follows from the following claim.

Claim. $\|\phi\| < \delta_N$ implies $|x(\phi, \sigma)(t)| < \varepsilon$ for all $t \geq 0$.

Proof of the Claim. Assume t_1 is the first switching instant and the i th subsystem is activated on $[t_0, t_1]$. Then conditions on V_i imply that

$$\begin{aligned} u(|x(\phi, \sigma)(t)|) &\leq V_i(x_t(\phi, \sigma)) \leq V_i(\phi) \\ &\leq v(\|\phi\|) \leq v(\delta_N) < u(\delta_{N-1}) \leq u(\varepsilon), \quad \forall t \in [0, t_1]. \end{aligned}$$

This gives $|x(\phi, \sigma)(t)| < \delta_{N-1} \leq \varepsilon$, $t \in [0, t_1]$. Since $\|\phi\| < \delta_N < \delta_{N-1} \leq \varepsilon$, it follows that $\|x_t(\phi, \sigma)\| < \delta_{N-1} \leq \varepsilon$. The claim is proved on the first dwell interval $[0, t_1]$. Particularly, we have $\|x_{t_1}(\phi, \sigma)\| < \delta_{N-1}$. Now assume t_2 is the second switching instant and j th subsystem is activated on $[t_1, t_2]$. Assume without loss of generality that $N \geq 2$ and $j \neq i$. Then conditions on V_j imply that

$$\begin{aligned} u(|x(\phi, \sigma)(t)|) &\leq V_j(x_t(\phi, \sigma)) \leq V_j(x_{t_1}(\phi, \sigma)) \\ &\leq v(\|\phi\|) \leq v(\delta_{N-1}) < u(\delta_{N-2}) \leq u(\varepsilon), \quad \forall t \in [t_1, t_2]. \end{aligned}$$

This gives $|x(\phi, \sigma)(t)| < \delta_{N-2} \leq \varepsilon$, $t \in [t_1, t_2]$. Since $\|\phi\| < \delta_{N-1} < \delta_{N-2} \leq \varepsilon$, it follows that $\|x_t(\phi, \sigma)\| < \delta_{N-2} \leq \varepsilon$. The claim is proved on the first dwell interval $[t_1, t_2]$. Particularly, we have $\|x_{t_2}(\phi, \sigma)\| < \delta_{N-2}$. The remaining of this proof is to repeat the above procedure over all switching instants. At each switching time, we may encounter either the case where a subsystem among the family is activated for the first time or the case where a subsystem activated once before is active again. In the former case, we can use the previous argument and show $|x(\phi, \sigma)(t)| < \delta_{N-m} \leq \varepsilon$ on the current dwell interval, where $m \leq N$ is such that $|x(\phi, \sigma)(t)| < \delta_{N-m+1} \leq \varepsilon$ holds on the previous dwell interval. In the latter case, Assumption 4.2.1 ensures that $|x(\phi, \sigma)(t)| < \delta_{N-n} \leq \varepsilon$ is conserved for the current dwell interval, where n is the number of subsystems that have been activated up to (and including) the current instant (not counting multiplicity). Since there exist only N subsystems in the family, the latter case can occur at most N times. Therefore $|x(\phi, \sigma)(t)| < \delta_0 \leq \varepsilon$ is guaranteed for all $t \geq 0$. This proves the claim and completes the proof. \square

Remark 4.2.4 It is clear from the proof of Proposition 4.2.3 that, as far as only local stability is concerned, we can actually replace Assumption 4.2.1 by the following weaker one: for some $i \in \mathcal{I}$ and every pair of switching instants $t_j < t_k$ such that $\sigma(t_j) = \sigma(t_k) = i$ and t_j is

the first time the i th mode is activated, we have

$$V_i(x_{t_k}(\phi, \sigma)) \leq V_i(x_{t_j}(\phi, \sigma)). \quad (4.2.9)$$

Inequality (4.2.9) is weaker than the one in Assumption 4.2.1, since it only requires that the value of V_i at the beginning of each interval on which $\sigma = i$ does not exceed the value of V_i at the very first time the i th mode is activated. This observation is in accordance with the case of general switched nonlinear systems not involving time-delays (see Theorem 2.4.1 and Remark 2.4.1 in Chapter 2). \square

Theorem 4.2.2 *Suppose that the conditions of Proposition 4.2.3 hold. Then the trivial solution $x = 0$ of system (4.1.1) is asymptotically stable with respect to $\mathcal{S}_{weak}^i(\tau)$, provided that $\tau \geq r$ and $M_i(\tau) \subset \mathcal{C}_0$. If $\tau \geq r$ and $\bigcup_{i \in \mathcal{I}} M_i(\tau) \subset \mathcal{C}_0$, then the trivial solution $x = 0$ of system (4.1.1) is asymptotically stable with respect to $\mathcal{S}_{weak}(\tau)$.*

Proof. Lyapunov stability of $x = 0$ follows from Proposition 4.2.3. Given some $\varepsilon_0 > 0$, let $\delta(\varepsilon_0)$ be the local stability constant found in the proof for Proposition 4.2.3 ($\delta_N(\varepsilon_0)$ there). Then any solution enters $\mathcal{B}_{\delta(\varepsilon_0)}$ will remain in $\mathcal{B}_{\delta(\varepsilon_0)}$ for all future time. We claim that $\mathcal{B}_{\delta(\varepsilon_0)}$ is a domain of attraction for (4.1.1), i.e., any solution starting from $\mathcal{B}_{\delta(\varepsilon_0)}$ converges to 0. Actually, since $\|x_t(\phi, \sigma)\| < \varepsilon_0$, $x(\phi, \sigma)$ is a bounded solution. According to Theorem 4.2.1, $x(\phi, \sigma)$ weakly approaches $M_i(\tau) \subset \mathcal{C}_0$ in the i th mode, which shows

$$\lim_{\substack{t \rightarrow \infty \\ t \in \mathcal{D}_i}} \text{dist}(x_t(\phi, \sigma), M_i(\tau)) = 0. \quad (4.2.10)$$

To show that $x_t(\phi, \sigma) \rightarrow 0$ as $t \rightarrow \infty$, choose an arbitrary $\varepsilon \in (0, \varepsilon_0)$ and let $\delta(\varepsilon)$ be the local stability constant found in the proof for Proposition 4.2.3 (δ_N there). Then any solution enters $\mathcal{B}_{\delta(\varepsilon)}$ will remain in $\mathcal{B}_{\delta(\varepsilon)}$ for all future time. Now (4.2.10) implies that there exists some $T_1 \geq 0$ such that

$$\text{dist}(x_t(\phi, \sigma), M_i(\tau)) < \frac{\delta(\varepsilon)}{2}, \quad \forall t \geq T_1, t \in \mathcal{D}_i.$$

Particularly, there exists an interval $[T_2, T_3] \subset \mathcal{D}_i$ with $T_2 \geq T_1$ and $T_3 - T_2 \geq \tau \geq r$ such that

$$\text{dist}(x_t(\phi, \sigma), M_i(\tau)) < \frac{\delta(\varepsilon)}{2}, \quad \forall t \in [T_2, T_3],$$

which implies that, for each $t \in [T_2, T_3]$, there exists some $\psi_t \in M_i(\tau)$ such that

$$\|x_t - \psi_t\| < \delta(\varepsilon). \quad (4.2.11)$$

Since $M_i(\tau) \subset \mathcal{C}_0$, it follows from (4.2.11) that

$$|x(t)| < \delta(\varepsilon), \quad \forall t \in [T_2, T_3].$$

Since $T_3 - T_2 \geq r$, this shows $\|x_{T_3}(\phi, \sigma)\| < \delta(\varepsilon)$ and hence $|x(\phi, \sigma)(t)| < \varepsilon$ for all $t \geq T_3$, i.e., we have shown $x(\phi, \sigma)(t) \rightarrow 0$ as $t \rightarrow \infty$. Hence the trivial solution is asymptotically stable with respect to $\mathcal{S}_{\text{weak}}^i(\tau)$. The last assertion of the theorem follows from the fact that $\mathcal{S}_{\text{weak}}(\tau) = \bigcup_{i \in \mathcal{I}} \mathcal{S}_{\text{weak}}^i(\tau)$. \square

Theorem 4.2.3 *Suppose that*

(i) $\{V_i : i \in \mathcal{I}\}$ *is a family of MLFs for (4.1.1) on \mathcal{C} satisfying*

$$u(|\phi(0)|) \leq V_i(\phi) \leq v(\|\phi\|), \quad \forall \phi \in \mathcal{C}, i \in \mathcal{I},$$

where u and v are of class \mathcal{KL} ; and

(ii) *Assumption 4.2.1 is satisfied for all $i \in \mathcal{I}$.*

Then the trivial solution $x = 0$ of system (4.1.1) is globally asymptotically stable with respect to $\mathcal{S}_{\text{weak}}^i(\tau)$, provided that $\tau \geq r$ and $M_i(\tau) \subset \mathcal{C}_0$. If $\tau \geq r$ and $\bigcup_{i \in \mathcal{I}} M_i(\tau) \subset \mathcal{C}_0$, then the trivial solution $x = 0$ of system (4.1.1) is globally asymptotically stable with respect to $\mathcal{S}_{\text{weak}}(\tau)$.

Proof. Lyapunov stability remains the same. To show global attraction, we only have to show that the constant $\delta(\varepsilon_0)$ in the proof for Theorem 4.2.2 can be chosen to be arbitrarily large, provided that ε_0 is given sufficiently large. Now given any $\varepsilon_0 > 0$, we let $\delta_0 = \varepsilon_0$ and define $\delta_1, \delta_2, \dots, \delta_N$ recursively such that $v(\delta_{j+1}) = u(\delta_j/2)$ for $j = 0, 1, 2, \dots, N-1$, where N is the cardinality of \mathcal{I} . Since $u(\delta_j/2) < u(\delta_j)$, it is clear that this choice of $\delta_1, \delta_2, \dots, \delta_N$ is in accordance with that in the proof of Proposition 4.2.3. Moreover, as $\varepsilon_0 \rightarrow \infty$, so is $\delta_1, \delta_2, \dots$, and δ_N . Therefore $\delta(\varepsilon_0) = \delta_N(\varepsilon_0)$ can be arbitrarily large if ε_0 is given sufficiently large. This completes the proof. \square

Remark 4.2.5 It is clear from the proof of Theorem 4.2.2 that, if we have $M_i(\tau) = \{0\}$ or $\bigcup_{i \in \mathcal{I}} M_i(\tau) = \{0\}$, then the conclusions of Theorems 4.2.2 and 4.2.3 hold without the restriction $\tau \geq r$. However, as shown by examples later in Section 4.2.6, if we want to show $M_i(\tau) = \{0\}$ or $\bigcup_{i \in \mathcal{I}} M_i(\tau) = \{0\}$, it is often (if not always) required that $\tau \geq r$. \square

The following corollary follows immediately from Theorem 4.2.3.

Corollary 4.2.1 *Suppose that the conditions of Theorem 4.2.3 are satisfied. If for some $i \in \mathcal{I}$, $D^+V_i(\phi) < 0$ and $D^-V_i(\phi) < 0$ for all $\phi \in \mathcal{C}$ such that $|\phi(0)| \neq 0$, then the trivial solution $x = 0$ of system (4.1.1) is globally asymptotically stable with respect to $\mathcal{S}_{weak}^i(\tau)$ for any $\tau \geq r$. If $D^+V_i(\phi) < 0$ and $D^-V_i(\phi) < 0$ for all $\phi \in \mathcal{C}$ such that $|\phi(0)| \neq 0$ and all $i \in \mathcal{I}$, then the trivial solution $x = 0$ of system (4.1.1) is globally asymptotically stable with respect to $\mathcal{S}_{weak}(\tau)$ for any $\tau \geq r$.*

4.2.4 Instability

The following theorem gives a test for instability of switched delay systems based on the invariance principle given by Theorem 4.2.1.

Theorem 4.2.4 *Let G be a subset of \mathcal{C} such that $0 \in \overline{G}$. Assume that there exist a family of MLFs $\{V_i : i \in \mathcal{I}\}$ for (4.1.1) on G such that, for some $i \in \mathcal{I}$,*

(i) $M_i(\tau) \cap G$ is either empty or zero,

(ii) $V_i(\phi) < \varepsilon$ on G when $\phi \neq 0$,

(iii) $V_i(0) = \varepsilon$ and $V_i(\phi) = \varepsilon$ when $\phi = \partial G$, where ∂G is the boundary of G .

Suppose, in addition, that Assumption 4.2.1 is satisfied for this i . Then given $\phi \in G \cap \mathcal{B}_\rho$, for any $\rho > 0$, and $\phi \neq 0$, the solution $x_t(\phi, \sigma)$ intersects $\partial \mathcal{B}_\rho$ in finite time, provided that $\sigma \in \mathcal{S}_{weak}^i(\tau)$ and $0 \in \mathcal{D}_i$.

Proof. For any $\rho > 0$, let $\phi \in G \cap \mathcal{B}_\rho$ and $\phi \neq 0$. Conditions on V_i imply that V_i is nonincreasing on \mathcal{D}_i . Moreover, $0 \in \mathcal{D}_i$ and hence

$$V_i(x_t(\phi, \sigma)) \leq V_i(\phi) < \varepsilon, \quad (4.2.12)$$

as long as $t \in \mathcal{D}_i$ and $x_t(\phi, \sigma)$ remains in $G \cap \mathcal{B}_\rho$. If $x_t(\phi, \sigma)$ remains in the bounded set $G \cap \mathcal{B}_\rho$ for all $t \in \mathcal{D}_i$, then, by Theorem 4.2.1, $x(\phi, \sigma)$ weakly approaches $M_i(\tau) = \{0\}$ in the i th mode. However, $V_i(0) = \varepsilon$. This contradicts (4.2.12). Therefore, there exists some $s > 0$ (not necessarily $s \in \mathcal{D}_i$) such that $x_s(\phi, \sigma) \in \partial(G \cap \mathcal{B}_\rho)$. Since $V_i(\phi) = \varepsilon$ on ∂G , we must have $x_s(\phi, \sigma) \in \partial \mathcal{B}_\rho$ and the theorem is proved. \square

4.2.5 Extensions by Multiple Lyapunov-Razumikhin Functions

As pointed out in the introduction, [60] extended the work of [63] by using Lyapunov-Razumikhin function. One of the major advantages of the results in [60] is that a Lyapunov-Razumikhin function can be easier to find than a Lyapunov functional from a practical point of view. In this section, we incorporate the idea of [60] and establish an invariance principle for switched delay systems using multiple Lyapunov-Razumikhin functions. The results in this section are based on the results established in the previous sections using MLFs and, therefore, can be seen as a unification of the results of [60] and [63], now in the hybrid switching setting.

Some notations for using Lyapunov-Razumikhin functions are introduced in the following, which are parallel to those for MLFs.

Definition 4.2.8 Let V be a continuous function from \mathcal{R}^n to \mathcal{R} , ϕ a function in \mathcal{C} , and χ a solution piece of (4.1.1.i) on $[\alpha, \beta]$, with $\alpha \leq 0 \leq \beta$ and $\beta - \alpha > 0$, and $\chi_0 = \phi$. If $\beta > 0$, define the upper right-hand derivative of V with respect to the i th mode of (4.1.1) to be

$$D^+ V_i(\phi(0)) = \limsup_{h \rightarrow 0^+} \frac{1}{h} [V(\chi_h(\phi)(0)) - V(\phi(0))]. \quad (4.2.13)$$

If $\alpha < 0$, define the upper left-hand derivative of V with respect to the i th mode of (4.1.1) to be

$$D^- V_i(\phi(0)) = \limsup_{h \rightarrow 0^-} \frac{1}{h} [V(\chi_h(\phi)(0)) - V(\phi(0))]. \quad (4.2.14)$$

□

Remark 4.2.6 If $V(x)$ is continuously differentiable, then (4.2.13) and (4.2.14) reduce to

$$D^+ V_i(\phi(0)) = D^- V_i(\phi(0)) = \nabla V(\phi(0)) \cdot f_i(\phi),$$

where ∇ is the gradient. □

Definition 4.2.9 A family of continuous functions $\{V_i : i \in \mathcal{I}\}$ from \mathcal{R}^n to \mathcal{R} are called **multiple Lyapunov-Razumikhin functions** (MLRFs) for system (4.1.1) on a set $G \subset \mathcal{C}$ if, for each $i \in \mathcal{I}$, V_i is continuous on \mathcal{R}^n and, for all $\phi \in G$ such that $V_i(\phi(0)) = \max_{-r \leq s \leq 0} V_i(\phi(s))$, we have $D^+ V_i(\phi(0)) \leq 0$. □

The following proposition bridges the notions of MLFs and MLRFs.

Proposition 4.2.4 *Let $\{V_i : i \in \mathcal{I}\}$ be a family of MLRFs for (4.1.1) on G . Then the family of functionals $\{\bar{V}_i : i \in \mathcal{I}\}$, defined by*

$$\bar{V}_i(\phi) := \max_{-r \leq s \leq 0} V_i(\phi(s)), \quad (4.2.15)$$

are a family of MLFs for (4.1.1) on G .

Proof. It can be shown that

$$D^+ \bar{V}_i(\phi) \leq 0,$$

for each $\phi \in G$ and $i \in \mathcal{I}$ (see, e.g., [62, p. 152]). Therefore, $\{\bar{V}_i : i \in \mathcal{I}\}$ form a family of MLFs for (4.1.1) on G . \square

Let $\{V_i : i \in \mathcal{I}\}$ be a family of MLRFs for (4.1.1) on $G \subset \mathcal{C}$. The notation \bar{V}_i refers exclusively to the one defined in (4.2.15). For some $\tau > 0$, define E_i to be the set of all $\phi \in \bar{G}$ such that there exists a solution piece χ of (4.1.1.i) on some interval $[\alpha, \beta]$, with $\beta - \alpha > 0$ and $\alpha \leq 0 \leq \beta$, satisfying $\chi_0 = \phi$ and $\bar{V}_i(\chi_t) \equiv c$, some constant, on $[\alpha, \beta]$. Let $M_i(\tau)$ be the largest set in E_i that is weakly τ -invariant with respect to the i th mode of (4.1.1).

The following results follow immediately from those in the previous section.

Theorem 4.2.5 (Weak Invariance) *Let $\{V_i : i \in \mathcal{I}\}$ be a family of MLRFs for (4.1.1) on G , $x(\phi, \sigma)$ be a solution of (4.1.1) such that $x_t(\phi, \sigma)$ remains in G for $t \geq 0$, $i \in \mathcal{I}$ be a τ -persistent mode of σ , and $x(\phi, \sigma)$ is bounded in the i th mode. Suppose, in addition, that Assumption 4.2.1 is satisfied for \bar{V}_i with this i . Then $x(\phi, \sigma)$ weakly approaches M_i in the i th mode as $t \rightarrow \infty$.*

Proposition 4.2.5 (Local Stability) *Suppose that*

(i) *$\{V_i : i \in \mathcal{I}\}$ is a family of MLRFs for (4.1.1) on \mathcal{B}_ρ for some $\rho > 0$ satisfying*

$$u(|x|) \leq V_i(x) \leq v(|x|), \quad \forall |x| < \rho, i \in \mathcal{I},$$

where u and v of class \mathcal{K} ; and

(ii) *Assumption 4.2.1 is satisfied for \bar{V}_i with all $i \in \mathcal{I}$.*

Then the trivial solution $x = 0$ of system (4.1.1) is stable.

Proof. It is easy to see that

$$u(|\phi(0)|) \leq \bar{V}_i(\phi) \leq v(\|\phi\|), \quad \forall \phi \in \mathcal{B}_\rho, i \in \mathcal{I}.$$

The conclusion follows from Proposition 4.2.3. \square

Theorem 4.2.6 (Asymptotic Stability) *Suppose that the conditions of Proposition 4.2.5 hold. Then the trivial solution $x = 0$ of system (4.1.1) is asymptotically stable with respect to $\mathcal{S}_{weak}^i(\tau)$, provided that $\tau \geq r$ and $M_i(\tau) \subset \mathcal{C}_0$. If $\tau \geq r$ and $\bigcup_{i \in \mathcal{I}} M_i(\tau) \subset \mathcal{C}_0$, then the trivial solution $x = 0$ of system (4.1.1) is asymptotically stable with respect to $\mathcal{S}_{weak}(\tau)$.*

Theorem 4.2.7 (Global Asymptotic Stability) *Suppose that*

(i) $\{V_i : i \in \mathcal{I}\}$ *is a family of MLRFs for (4.1.1) on \mathcal{C} satisfying*

$$u(|x|) \leq V_i(x) \leq v(|x|), \quad \forall x \in \mathcal{R}^n, i \in \mathcal{I},$$

where u and v are of class \mathcal{KL} ; and

(ii) *Assumption 4.2.1 is satisfied for \bar{V}_i with all $i \in \mathcal{I}$.*

Then the trivial solution $x = 0$ of system (4.1.1) is globally asymptotically stable with respect to $\mathcal{S}_{weak}^i(\tau)$, provided that $\tau \geq r$ and $M_i(\tau) \subset \mathcal{C}_0$. If $\bigcup_{i \in \mathcal{I}} M_i(\tau) \subset \mathcal{C}_0$, the trivial solution $x = 0$ of system (4.1.1) is globally asymptotically stable with respect to $\mathcal{S}_{weak}(\tau)$.

Corollary 4.2.2 (Global Asymptotic Stability) *Suppose that the conditions of Theorem 4.2.7 are satisfied. If for some $i \in \mathcal{I}$, $D^- V_i(\phi(0)) < 0$ for all $\phi \in \mathcal{C}$ such that $|\phi(0)| \neq 0$ and $V_i(\phi(0)) = \max_{-r \leq s \leq 0} V_i(\phi(s))$, then the trivial solution $x = 0$ of system (4.1.1) is globally asymptotically stable with respect to $\mathcal{S}_{weak}^i(\tau)$ for any $\tau > r$. If $D^- V_i(\phi(0)) < 0$ for all $i \in \mathcal{I}$ and all $\phi \in \mathcal{C}$ such that $|\phi(0)| \neq 0$ and $V_i(\phi(0)) = \max_{-r \leq s \leq 0} V_i(\phi(s))$, then the trivial solution $x = 0$ of system (4.1.1) is globally asymptotically stable with respect to $\mathcal{S}_{weak}(\tau)$ for any $\tau > r$.*

Remark 4.2.7 *It is pointed out that, compared to Corollary 4.2.1, Corollary 4.2.2 requires a slightly stronger weak dwell-time condition $\tau > r$ and a Razumikhin-type condition only on the upper left-hand derivative of V_i . \square*

Proof. To show that $M_i(\tau) = \{0\}$, we pick any $\psi \in M_i$ and assume that $\psi \neq 0$. There exists a solution piece χ of (4.1.1.i) on $[\alpha, \beta]$ with $\beta - \alpha \geq \tau > r$ such that $\chi_0 = \psi$ and $\chi_t \in M_i(\tau)$ for all $t \in [\alpha, \beta]$. By the definition of $M_i(\tau)$, $\bar{V}_i(\chi_t)$ is constant on $[\alpha, \beta]$. Then there must exist some $\theta \in (\alpha, \beta]$ such that $V_i(\chi_\theta(0)) = \max_{-r \leq s \leq 0} V_i(\chi_\theta(s))$. By the conditions on V_i , this would imply $D^- V_i(\chi_\theta(0)) < 0$. However, as $V_i(\chi_t(0))$ attains a local maximum at $t = \theta$, we have $D^- V_i(\chi_\theta(0)) \geq 0$, which is a contradiction. Therefore, $M_i = \{0\}$ and the conclusions of the corollary follow from Theorem 4.2.7. \square

Theorem 4.2.8 (Instability) *Let G be a subset of \mathcal{C} such that $0 \in \bar{G}$. Assume that there exist a family of MLRFs $\{V_i : i \in \mathcal{I}\}$ for (4.1.1) on G such that, for some $i \in \mathcal{I}$,*

(i) $M_i(\tau) \cap G$ is either empty or zero,

(ii) $\bar{V}_i(\phi) < \varepsilon$ on G when $\phi \neq 0$,

(iii) $V_i(0) = \varepsilon$ and $\bar{V}_i(\phi) = \varepsilon$ when $\phi = \partial G$, where ∂G is the boundary of G .

Suppose, in addition, that Assumption 4.2.1 is satisfied for \bar{V}_i with this i . Then given $\phi \in G \cap \mathcal{B}_\rho$, for any $\rho > 0$, and $\phi \neq 0$, the solution $x_t(\phi, \sigma)$ intersets $\partial \mathcal{B}_\rho$ in finite time, provided that $\sigma \in \mathcal{S}_{weak}^i(\tau)$ and $0 \in \mathcal{S}_{weak}^i(\tau)$.

4.2.6 Examples

Example 4.2.1² Consider

$$\dot{x}(t) = a_\sigma x^3(t) + b_\sigma x^3(t-r), \quad (4.2.16)$$

where $\sigma : \mathcal{R}^+ \rightarrow \mathcal{I}$ is a switching signal. Assume that $a_i \neq 0$ for all $i \in \mathcal{I}$.

MLF Approach: Define

$$V_i(\phi) = -\frac{\phi^4(0)}{2a_i} + \int_{-r}^0 \phi^6(s) ds,$$

for each $i \in \mathcal{I}$. Let χ be a solution piece of (4.1.1.i) on $[\alpha, \beta]$ with $\chi_0 = \phi$. Then

$$V_i(\chi_t) = -\frac{\chi^4(t)}{2a_i} + \int_{t-r}^t \chi^6(s) ds, \quad \forall t \in [\alpha, \beta].$$

²The example is modified from Example (3.2) in Chapter 5 of [62], which was originally due to [103].

Differentiating $V_i(\chi_t)$ at $t = 0$ (assume $\alpha < 0$ and $\beta > 0$) gives

$$D^+ V_i(\phi) = D^- V_i(\phi) = -\left[\phi^6(0) + \frac{2b_i}{a_i}\phi^3(0)\phi^3(-r) + \phi^6(-r)\right]. \quad (4.2.17)$$

Hence $\{V_i : i \in \mathcal{I}\}$ forms a family of MLFs for (4.2.16) on \mathcal{C} if $|b_i| \leq |a_i|$ for all $i \in \mathcal{I}$. Moreover,

(I) if $a_i < 0$ and $|b_i| \leq |a_i|$ for all $i \in \mathcal{I}$, then condition (i) of Theorem 4.2.3 is satisfied.

Assume that Assumption 4.2.1 is satisfied for all $i \in \mathcal{I}$.

(i) If $|b_i| < |a_i|$ for some $i \in \mathcal{I}$, then, in view of Proposition 4.2.2 and (4.2.17), $E_i \subset \{\phi \in \mathcal{C} : \phi(0) = \phi(-r) = 0\} \subset \mathcal{C}_0$. Theorem 4.2.3 implies that the solution $x = 0$ of (4.2.16) is globally asymptotically stable with respect to $\mathcal{S}_{\text{weak}}^i(\tau)$ for $\tau \geq r$.³

(ii) If $b_i = a_i$ for some $i \in \mathcal{I}$, then, in view of Proposition 4.2.2 and (4.2.17), $E_i \subset \{\phi \in \mathcal{C} : \phi(0) = -\phi(-r)\}$. Choose any $\psi \in M_i(\tau)$. Since $M_i(\tau)$ is weakly τ -invariant with respect to the i th mode of (4.2.16) and $M_i(\tau) \subset E_i$, there exists a solution piece χ of (4.1.1.i) on $[\alpha, \beta]$, with $0 \in [\alpha, \beta]$ and $\beta - \alpha \geq \tau$, such that $\chi_0 = \psi$ and $\chi_t \in M_i(\tau) \subset E_i \subset \{\phi \in \mathcal{C} : \phi(0) = -\phi(-r)\}$ for all $t \in [\alpha, \beta]$, i.e., $\chi(t) = -\chi(t - r)$ for all $t \in [\alpha, \beta]$, which implies $\dot{\chi}(t) \equiv 0$ on $[\alpha, \beta]$ and hence $\chi(t) \equiv c$, some constant, on $[\alpha, \beta]$. If $\tau \geq r$, $\chi(t) = -\chi(t - r)$ implies $c = 0$ and hence $\psi = 0$. Therefore $M_i(\tau) = \{0\}$. Theorem 4.2.3 implies that $x = 0$ is globally asymptotically stable with respect to $\mathcal{S}_{\text{weak}}^i(\tau)$ for $\tau \geq r$.

(iii) If, for each $i \in \mathcal{I}$, either $|b_i| < |a_i|$ or $b_i = a_i$, then, summarizing (i) and (ii) above, the solution $x = 0$ of (4.2.16) is globally asymptotically stable with respect to $\mathcal{S}_{\text{weak}}(\tau)$ for $\tau \geq r$.

(II) If $a_i > 0$ and $|b_i| < a_i$ (or $b_i = a_i$) for some $i \in \mathcal{I}$, then the set $G = \{\phi \in \mathcal{C} : V_i(\phi) < 0\}$ is nonempty. As before, if $\tau \geq r$, we can show that $M_i(\tau) = \{0\}$. Choosing $\varepsilon = 0$ in Theorem 4.2.4 shows that $x = 0$ is unstable with respect to $\mathcal{S}_{\text{weak}}^i(\tau)$ for $\tau \geq r$, provided that Assumption 4.2.1 is satisfied for this i .

CLF Approach: Define

$$V(\phi) = -\frac{\phi^4(0)}{2a} + \int_{-r}^0 \phi^6(s) ds.$$

³With $\tau \geq r$, we can also directly show that $M_i(\tau) = \{0\}$ as in case (ii) below.

Then

$$D^+V(\phi) = D^-V(\phi) = -\left[\left(\frac{2a_i}{a} - 1\right)\phi^6(0) + \frac{2b_i}{a}\phi^3(0)\phi^3(-r) + \phi^6(-r)\right]. \quad (4.2.18)$$

If $|b_i| \leq |a|$ and $a_i \geq a$ for all $i \in \mathcal{I}$, then V is a CLF for (4.2.16) on \mathcal{C} . Assumption 4.2.1 is trivially satisfied if we choose $V_i = V$ for each $i \in \mathcal{I}$. Using the same argument as in the case of MLFs, we can show that, if $a_i < 0$ for all $i \in \mathcal{I}$ and, for each $i \in \mathcal{I}$, either $|b_i| < |a|$ or $b_i = a$, where $a = \max\{a_i : i \in \mathcal{I}\}$, then the trivial solution $x = 0$ of (4.2.16) is globally asymptotically stable with respect to $\mathcal{S}_{\text{weak}}(\tau)$ for $\tau \geq r$.

Remark 4.2.8 As we can see, getting rid of Assumption 4.2.1 by a CLF approach, more severe conditions on the coefficients a_i and b_i are required. \square

CLRF Approach:

(I) If $a_i < 0$ and $|b_i| \leq |a_i|$ for all $i \in \mathcal{I}$, define

$$V_i(x) = V(x) = \frac{x^2}{2},$$

for all $i \in \mathcal{I}$. Then

$$D^+V_i(\phi(0)) = D^-V_i(\phi(0)) = a_i\phi^4(0) + b_i\phi(0)\phi^3(-r),$$

and, clearly, V is a CLRF for (4.2.16) on \mathcal{C} . Assumption 4.2.1 is trivially satisfied for all $i \in \mathcal{I}$. If $|b_i| < |a_i|$ for some $i \in \mathcal{I}$, then by Corollary 4.2.2, the trivial solution $x = 0$ of (4.2.16) is globally asymptotically stable with respect to $\mathcal{S}_{\text{weak}}^i(\tau)$ for any $\tau > r$. If $|b_i| < |a_i|$ for all $i \in \mathcal{I}$, then the trivial solution $x = 0$ of (4.2.16) is globally asymptotically stable with respect to $\mathcal{S}_{\text{weak}}(\tau)$ for any $\tau > r$.

(II) If $a_i > 0$ and $|b_i| < a_i$ (or $b_i = a_i$) for some $i \in \mathcal{I}$, define

$$V_i(x) = -\frac{x^2}{2},$$

and $V_{p'}(x) \equiv 0$ for all $p' \in \mathcal{I}$ such that $p' \neq p$. Then

$$D^+V_i(\phi(0)) = D^-V_i(\phi(0)) = -a_i\phi^4(0) - b_i\phi(0)\phi^3(-r),$$

and, clearly, $\{V_i : i \in \mathcal{I}\}$ is a family of MLRFs for (4.2.16) on \mathcal{C} . the set $G = \{\phi \in \mathcal{C} : \bar{V}_i(\phi) < 0\}$ is nonempty. If $\tau > r$, as in the proof for Corollary 4.2.2, we can show that $M_i(\tau) = \{0\}$. Choosing $\varepsilon = 0$ in Theorem 4.2.8 shows that $x = 0$ is unstable

with respect to $\mathcal{S}_{\text{weak}}^i(\tau)$ for $\tau > r$, provided that Assumption 4.2.1 is satisfied for \bar{V}_i with this i . \square

Remark 4.2.9 By using a CLRF, not only do we get rid of Assumption 4.2.1, we also get less conservative stability conditions on the coefficients a_i and b_i , compared to the CLF approach. \square

Example 4.2.2⁴ Consider the system

$$A_\sigma \ddot{x}(t) + B_\sigma x(t) = \int_0^r F_\sigma(\theta) x(t - \theta) d\theta, \quad (4.2.19)$$

where $\sigma : \mathcal{R}^+ \rightarrow \mathcal{I}$ is a switching signal. For each $i \in \mathcal{I}$, a_i , b_i , and F_i are symmetric $n \times n$ matrices and F_i is continuously differentiable. Let

$$H_i = b_i - \int_0^r F_i(\theta) d\theta, \quad i \in \mathcal{I},$$

and write system (4.2.19) as

$$\begin{cases} \dot{x}(t) = y(t), \\ A_\sigma \dot{y}(t) = -H_\sigma x(t) + \int_0^r F_\sigma(\theta) [x(t - \theta) - x(t)] d\theta. \end{cases} \quad (4.2.20)$$

The stability analysis of (4.2.20) is summarized in the following theorem, which generalizes Theorem 3.5 in Chapter 5 of [62] to the hybrid setting.

Theorem 4.2.9 (i) If $a_i > 0$, $H_i > 0$, $F_i(\theta) \geq 0$ on $[0, r]$, $\dot{F}_i(\theta) \leq 0$ on $[0, r]$, for all $i \in \mathcal{I}$, and there exists a θ_0 in $[0, r]$ and some $i_0 \in \mathcal{I}$ such that $\dot{F}_{i_0}(\theta_0) < 0$, then the trivial solution $(0, 0)$ of (4.2.20) is globally asymptotically stable with respect to $\mathcal{S}_{\text{weak}}^{i_0}(\tau)$ with $\tau \geq r$. If, for each $i \in \mathcal{I}$, there exists a θ_0 in $[0, r]$ such that $\dot{F}_i(\theta_0) < 0$, then the trivial solution $(0, 0)$ of (4.2.20) is globally asymptotically stable with respect to $\mathcal{S}_{\text{weak}}(\tau)$ with $\tau \geq r$.

(ii) If $a_i > 0$, $H_i > 0$, $\dot{F}_i \equiv 0$, and $F_i > 0$ for all $i \in \mathcal{I}$, then all solutions of (4.2.20) are bounded and the τ -persistent limit set of any solution in the i_0 -th mode must be generated by r -periodic solution pieces of the ordinary system

$$\dot{x} = y, \quad A_{i_0} \dot{y} = -B_{i_0} x. \quad (4.2.21)$$

⁴This example is modified from Example (3.11) in Chapter 5 of [62].

(iii) If $a_i > 0$, $H_i < 0$, $F_i(r) \geq 0$, $\dot{F}_i \leq 0$ on $[0, r]$, for all $i \in \mathcal{I}$, and there exists a θ_0 and some $i_0 \in \mathcal{I}$ such that $\dot{F}_{i_0}(\theta_0) < 0$, then the trivial solution $(0, 0)$ of (4.2.20) is unstable with respect to $\mathcal{S}_{weak}^{i_0}(r)$.

Proof. Let ϕ, ψ be the initial values for x, y in (4.2.20) and define, for each $i \in \mathcal{I}$,

$$\begin{aligned} V_i(\phi, \psi) &= \frac{1}{2}\phi(0)^T H_i \phi(0) + \frac{1}{2}\psi(0)^T a_i \psi(0) \\ &\quad + \frac{1}{2} \int_0^r [\phi(-\theta) - \phi(0)]^T F_i(\theta) [\phi(-\theta) - \phi(0)] d\theta. \end{aligned}$$

It is easy to show that

$$\begin{aligned} D^+ V_i(\phi, \psi) &= D^- V_i(\phi, \psi) = -\frac{1}{2}[\phi(-r) - \phi(0)]^T F_i(r) [\phi(-r) - \phi(0)] \\ &\quad + \frac{1}{2} \int_0^r [\phi(-\theta) - \phi(0)]^T \dot{F}_i(\theta) [\phi(-\theta) - \phi(0)] d\theta \\ &\leq 0, \quad \forall i \in \mathcal{I}, \end{aligned} \tag{4.2.22}$$

if the conditions in (i), (ii), or (iii) are satisfied. If either (i) or (iii) is satisfied, then there exists some subinterval of $[0, r]$, say I_{θ_0} , such that $\dot{F}_{i_0}(\theta) < 0$ for $\theta \in I_{\theta_0}$. From (4.2.22), either $D^+ V_{i_0}(\phi, \psi) = 0$ or $D^- V_{i_0}(\phi, \psi) = 0$ implies that $\phi(\theta) - \phi(0) = 0$ for $\theta \in I_{\theta_0}$. From Proposition 4.2.2, $E_{i_0} \subset \{(\phi, \psi) : \phi(\theta) = \phi(0), \forall \theta \in I_{\theta_0}\}$. Now choose any $(\phi, \psi) \in M_{i_0}(\tau)$. Let (x, y) be a solution piece of (4.2.20) on $[\alpha, \beta]$, with $0 \in [\alpha, \beta]$ and $\beta - \alpha \geq \tau$, such that $(x_0, y_0) = (\phi, \psi)$ and $(x_t, y_t) \in M_{i_0}(\tau)$ for all $t \in [\alpha, \beta]$. It follows that $x(t - \theta) = x(t)$ for all $t \in [\alpha, \beta]$ and $\theta \in I_{\theta_0}$. Therefore $x(t) \equiv c$, a constant, on $[\alpha, \beta]$. From (4.2.20), this implies that $y(t) = 0$ on $[\alpha, \beta]$ and hence $H_{i_0}c = 0$. Either $H_{i_0} < 0$ or $H_{i_0} = 0$ in (i), (ii), or (iii). We must have $c = 0$. Therefore $M_{i_0}(\tau) \subset \mathcal{C}_0$.

- (1) If conditions in (i) are satisfied, Theorem 4.2.3 implies that the trivial solution $(0, 0)$ of (4.2.20) is globally asymptotically stable with respect to $\mathcal{S}(\tau, i_0)$ with $\tau \geq r$. If, for each $i \in \mathcal{I}$, there exists a θ_0 such that $\dot{F}_i(\theta_0) < 0$, then the trivial solution $(0, 0)$ of (4.2.20) is globally asymptotically stable with respect to $\mathcal{S}_{weak}(\tau)$ with $\tau \geq r$.
- (2) If conditions in (iii) are satisfied, then, by defining $G = \{V_{i_0}(\phi, \psi) < 0\}$, Theorem 4.2.4 implies that $(0, 0)$ is unstable.
- (3) If conditions in (ii) are satisfied, then $\dot{F}_{i_0} \equiv 0$ and either $D^+ V_{i_0}(\phi, \psi) = 0$ or $D^- V_{i_0}(\phi, \psi) = 0$ would imply that $\phi(-r) = \phi(0)$. From Proposition 4.2.2, $E_{i_0} \subset \{(\phi, \psi) : \phi(-r) = \phi(0)\}$. Now choose any $(\phi, \psi) \in M_{i_0}(\tau)$ and let (x, y) be a solution

piece of (4.2.20. i_0) on $[\alpha, \beta]$, with $0 \in [\alpha, \beta]$ and $\beta - \alpha \geq \tau$, such that $(x_0, y_0) = (\phi, \psi)$ and $(x_t, y_t) \in M_{i_0}(\tau)$ for all $t \in [\alpha, \beta]$. It follows that $x(t)$ satisfies $x(t - r) = x(t)$ for all $t \in [\alpha, \beta]$, and so does $y(t)$. The fact that $x(t - r) = x(t)$ for all $t \in [\alpha, \beta]$ implies that $\int_{t-r}^t x(s)ds \equiv c$, a constant, on $[\alpha, \beta]$. Integrating the second equation of (4.2.20), with $\sigma = i_0$, from $t - r$ to t , where $t \in [\alpha, \beta]$, gives

$$\begin{aligned} 0 &= A_{i_0}y(t) - A_{i_0}y(t - r) \\ &= -H_{i_0} \int_{t-r}^t x(s)ds + \int_{t-r}^t \int_0^r F_{i_0}[x(s - \theta) - x(s)]d\theta ds \\ &= -H_{i_0}c. \end{aligned}$$

Then $H_{i_0} > 0$ implies that $c = 0$. Therefore, with $\sigma = i_0$, (4.2.20) reduces to (4.2.21) and (x, y) satisfies (4.2.21) on $[\alpha, \beta]$ and (x, y) is periodic with period r .

The proof is complete. \square

4.3 Input-to-State and Integral Input-to-State Stability

In Section 3.3 of Chapter 3, we introduced and studied input-to-state stability for impulsive switched systems. In this section, we will study input-to-state stability (ISS) and integral input-to-state stability (iISS) properties of general hybrid systems with time-delay as described by system (4.1.3).

We mention that the notions of ISS/iISS have been generalized to nonlinear time-delay systems by various authors. In the seminal paper [169], the notion of ISS is extended to time-delay systems and sufficient conditions for ISS are investigated using Lyapunov-Razumkhin theorems. In [151], the method of Lyapunov functionals is proposed for studying ISS/iISS of time-delay systems and several sufficient conditions for ISS/iISS of time-delay systems are presented. In [195], a link is established between exponential stability of an unforced system and the ISS of time-delay systems using the method of Lyapunov functionals. It is also pointed out in [195] that the characterization of ISS/iISS for nonlinear time-delay systems remains a difficult task despite the recent progress. More recently, the work of [36] investigates both ISS and iISS for nonlinear impulsive systems with time delays. Sufficient conditions for ISS/iISS are established using the Lyapunov-Razumikhin method.

As we study input-to-state properties of system (4.1.3), the method of multiple Lyapunov functionals (sometimes called Lyapunov functionals by some authors) will be used. In

contrast with the Lyapunov-Razumkhin method presented in [36], it is well-known that the method of Lyapunov functionals are sometimes more general than the Lyapunov-Razumkhin method in the sense that the latter can be considered as a particular case of the method of Lyapunov functionals [94, Section 4.8, p. 254] (see also [151]), which is also demonstrated earlier in the Section 4.2 where we derived an invariance principle using MLRFs as an corollary of the result obtained using MLFs. The advantages in using the Lyapunov-Razumkhin method mostly lies in the fact that Lyapunov functions are general easier to find than Lyapunov functionals. For a more detailed discussion on the advantages and disadvantages of both methods in different situations, see [62, Section 5.5, pp. 164–165]. Therefore, it is worthwhile to study ISS properties of time-delay systems using the method of Lyapunov functionals, as shown in [151] and [195]. However, as far as impulsive stabilization of time-delay systems are concerned, the Lyapunov functional method is usually more difficult than the Lyapunov-Razumkhin method. The reason is that, in general, we cannot expect an impulse that occurs at a discrete time to bring the value of a functional down instantaneously, whereas, in the Lyapunov-Razumkhin method, the value of a function can subside simultaneously as the impulse occurs. For impulsive stabilization of time-delay systems using the Lyapunov functional methods, see [115] and [160]. Moreover, there have been no studies in the literature on the input-to-state properties of hybrid time-delay systems with both switching and impulse effects. The main objective of this section is to establish some results in this direction. It is also shown that the results to be presented in this section can be applied to systems with arbitrarily large delays and, therefore, improve those results in [36], [115], and [160]. Moreover, due to existence of different switching modes in system (4.1.3), we employ multiple Lyapunov functionals, in the spirit of work in [20] on multiple Lyapunov functions for switched systems.

The rest of this chapter is organized as follows. In Section 4.3.1, the concepts of input-to-state stability and integral input-to-state stability for general hybrid systems with time-delay as described by system (4.1.3) are presented. The main results on ISS/iISS, presented in Section 4.3.2, give sufficient conditions for input-to-state stability and integral input-to-state stability of impulsive switching hybrid time-delay systems in terms of Lyapunov functionals. Several examples are presented in Section 4.3.4 to illustrate the main results. This chapter is summarized by Section 4.4.

4.3.1 Preliminaries

We assume that, for each $i \in \mathcal{I}$ and $j \in \mathcal{J}$, $f_i(t, 0, 0) \equiv I_j(t, 0, 0) \equiv 0$ so that system (4.1.3), without input, admits a trivial solution.

Definition 4.3.1 System (4.1.3) is said to be **uniformly input-to-state stable (ISS)** over a certain class of signals \mathcal{S} , if there exist functions $\beta \in \mathcal{KL}$ and $\gamma \in \mathcal{K}_\infty$, independent of the choice of impulsive switching signals $\{(t_k, i_k, j_k)\}$ in \mathcal{S} , such that, for each initial data $\xi \in \mathcal{PC}$ and input function $w \in \mathcal{PC}(\mathcal{R}^+; \mathcal{R}^n)$, the solution x of (4.1.3) exists globally and satisfies

$$|x(t)| \leq \beta(\|\xi\|, t - t_0) + \gamma\left(\sup_{t_0 \leq s \leq t} |w(s)|\right).$$

Definition 4.3.2 System (4.1.3) is said to be **uniformly integral input-to-state stable (ISS)** over a certain class of signals \mathcal{S} , if there exist functions $\beta \in \mathcal{KL}$ and $\alpha, \gamma \in \mathcal{K}_\infty$, independent of the choice of impulsive switching signals $\{(t_k, i_k, j_k)\}$ in \mathcal{S} , such that, for each initial data $\xi \in \mathcal{PC}$ and input function $w \in \mathcal{PC}(\mathcal{R}^+; \mathcal{R}^n)$, the solution x of (4.1.3) exists globally and satisfies

$$\alpha(|x(t)|) \leq \beta(\|\xi\|, t - t_0) + \int_{t_0}^t \gamma(|w(s)|) ds + \sum_{t_0 < t_k \leq t} \gamma(|w(t_k^-)|).$$

The above definitions extend Definitions 3.3.1 and 3.3.2 to hybrid systems with time-delay, and are parallel to the ones given in [36], [67], and [151]. A minor distinction from the definitions in [36] is that we consider the inputs to the continuous dynamics and the discrete dynamics of system (4.1.3), namely $w(t)$ in both (4.1.3a) and (4.1.3b), to be the same. This simpler formulation is, nevertheless, without loss of generality. If given $w_c(t) \in \mathcal{R}^{m_1}$ as the input for the continuous dynamics and $w_d(t) \in \mathcal{R}^{m_2}$ as the input for the discrete dynamics (as in [36]), we can let $w(t) = [w_c(t) \ w_d(t)] \in \mathcal{R}^{m_1+m_2}$ and redefine f_i and I_j accordingly to achieve the formulation in (4.1.3).

A function $\nu : \mathcal{R}^+ \times \mathcal{R}^n \rightarrow \mathcal{R}^+$ is said to belong to **class ν_1** and we write $\nu \in \nu_1$, if, for each function $x \in \mathcal{PC}(\mathcal{R}^+; \mathcal{R}^n)$, the composite function $t \rightarrow \nu(t, x(t))$ is also in $\mathcal{PC}(\mathcal{R}^+; \mathcal{R}^n)$ and can be discontinuous at some $t' \in \mathcal{R}^+$ only if t' is a discontinuity point of x . A functional $\nu : \mathcal{R}^+ \times \mathcal{PC} \rightarrow \mathcal{R}^+$ is said to belong to **class ν_2** and we write $\nu \in \nu_2$, if, for each function $x \in \mathcal{PC}([-r, \infty); \mathcal{R}^n)$, the composite function $t \rightarrow \nu(t, x_t)$ is continuous in t for $t \geq 0$.

To investigate the ISS/iISS properties of system (4.1.3), which has different modes of the continuous dynamics given by $\{f_i : i \in \mathcal{I}\}$, we shall choose accordingly a family of multiple Lyapunov functionals $\{V_i : i \in \mathcal{I}\}$, where each $V_i : \mathcal{R}^+ \times \mathcal{PC} \rightarrow \mathcal{R}^+$ is given by

$$V_i(t, \phi) = V_1^i(t, \phi(0)) + V_2^i(t, \phi).$$

We shall assume that the family $\{V_1^i : i \in \mathcal{I}\}$ are of class ν_1 and the family $\{V_2^i : i \in \mathcal{I}\}$ are of class ν_2 . The intuitive idea is to break the Lyapunov functionals V_i into a function part V_1^i , which can effectively reflect the impulse effects, and a functional part V_2^i , which is indifferent to impulses, so that the difficulties in analyzing the impulse effects using Lyapunov functionals can be overcome.

To effectively analyze a family of multiple Lyapunov functionals $\{V_i : i \in \mathcal{I}\}$ for system (4.1.3), we introduce the upper right-hand derivative of V_i with respect to the i th mode of system (4.1.3), for each $i \in \mathcal{I}$, at $(t, \phi) \in \mathcal{R}^+ \times \mathcal{PC}$ is defined by

$$D^+ V_i(t, \phi) = \limsup_{h \rightarrow 0^+} \frac{1}{h} [V_i(t+h, x_{t+h}(t, \phi)) - V_i(t, \phi)], \quad (4.3.1)$$

where $x(t, \phi)$ is a solution to the i th mode of system (4.1.3a) satisfying $x_t = \phi$, i.e., $x(t) = x(t, \phi)$ satisfies $x_{t_0} = \phi$ and $x'(t) = f_i(t, x_t, w(t))$ for $t \in (t_0, t_0 + h)$, where $h > 0$ is some positive number. Clearly, the definition in (4.3.1) for the functional $D^+ V_i(t, \phi)$ is parallel to the definition in (4.2.1) for the switched delay system (4.1.1), now with domain $\mathcal{R}^+ \times \mathcal{PC}$ instead of $\mathcal{R}^+ \times \mathcal{C}$.

Moreover, for a function $v : \mathcal{R} \rightarrow \mathcal{R}$, $D^+ v(t)$ is the upper right-hand derivative of $v(t)$ defined by

$$D^+ v(t) = \limsup_{h \rightarrow 0^+} \frac{1}{h} [v(t+h) - v(t)].$$

Let $\{(t_k, i_k, j_k)\}$ be an impulsive switching signal and x be a solution to system (4.1.3) on $[t_k, t_{k+1})$. Define

$$v(t) = V_{i_k}(t, x_t) = V_1^i(t, x(t)) + V_2^i(t, x_t), \quad t \in [t_k, t_{k+1})$$

The above definitions for the upper right-hand derivative of a function $v(t)$ and a functional V_i , with respect to the i th mode of system (4.1.3a), are connected by $D^+ v(t) = D^+ V_{i_k}(t, x_t)$ for $t \in (t_k, t_{k+1})$. With this in mind, the functional $D^+ V_i(t, \phi)$ can be very useful in characterizing the evolution of the Lyapunov functional $V_i(t, \phi)$ along the solutions of the i th subsystem of (4.1.3a), which also attests the effectiveness of the Lyapunov functional method.

4.3.2 Input-to-State Stability

Given $\delta > 0$, let $\mathcal{S}_{\text{inf}}^i(\delta)$, $\mathcal{S}_{\text{sup}}^i(\delta)$, $\mathcal{S}_{\text{inf}}(\delta)$, and $\mathcal{S}_{\text{sup}}(\delta)$, be the classes of generalized dwell-time impulsive switching signals defined in Section 3.1.1.

Our first result is concerned with ISS properties of system (4.1.3), in the case when all the subsystems governing the continuous dynamics of (4.1.3) are stable and the impulses, on the other hand, are destabilizing. Intuitively, the conditions in the following theorem consist of four aspects (corresponding to each of the conditions): **(i)** the Lyapunov functionals satisfy certain positive definite and decrescent conditions; **(ii)** the jumps induced by the destabilizing impulses satisfy certain growth conditions; **(iii)** there exist some negative estimates of the upper right-hand derivatives of the functionals with respect to each stable mode of (4.1.3); and **(iv)** the estimates on the derivatives and the growth by jumps satisfy certain balancing conditions in terms of the dwell-time lower bounds.

Theorem 4.3.1 *Suppose that there exist a family of functions $\{V_1^i : i \in \mathcal{I}\}$ of class v_1 and a family of functionals $\{V_2^i : i \in \mathcal{I}\}$ of class v_2 , functions $\alpha_1, \alpha_2, \alpha_3$, and χ of class \mathcal{K}_∞ , positive constants $\lambda > 0$, $\rho_i \geq 1$, δ_i , and $\mu_i > \lambda$ ($i \in \mathcal{I}$) such that, for all $i, \tilde{i} \in \mathcal{I}, j \in \mathcal{J}, t \in \mathcal{R}^+$, $x \in \mathcal{R}^n$, $y \in \mathcal{R}^m$, and $\phi \in \mathcal{PC}$,*

$$(i) \quad \alpha_1(|x|) \leq V_1^i(t, x) \leq \alpha_2(|x|) \quad \text{and} \quad 0 \leq V_2^i(t, \phi) \leq \alpha_3(\|\phi\|);$$

$$(ii) \quad V_1^{\tilde{i}}(t, \phi(0) + I_j(t, \phi, y)) \leq \rho_i V_1^i(t^-, \phi(0)) + \chi(|y|) \quad \text{and} \quad V_2^{\tilde{i}}(t, \phi) \leq \rho_i V_2^i(t, \phi);$$

$$(iii) \quad D^+ V_i(t, \phi) \leq -\mu_i V_i(t, \phi) + \chi(|w(t)|), \quad \text{where} \quad V_i(t, \phi) = V_1^i(t, \phi(0)) + V_2^i(t, \phi);$$

$$(iv) \quad \ln \rho_i < (\mu_i - \lambda)\delta_i.$$

Moreover, suppose that $\sup_{i \in \mathcal{I}} \rho_i < \infty$, $\inf_{i \in \mathcal{I}} \delta_i > 0$, and $\inf_{i \in \mathcal{I}} \mu_i > \lambda$. Then system (4.1.3) is uniformly ISS over $\bigcap_{i \in \mathcal{I}} \mathcal{S}_{\text{inf}}^i(\delta_i)$. In particular, if $\delta = \sup_{i \in \mathcal{I}} \delta_i < \infty$, system (4.1.3) is uniformly ISS over $\mathcal{S}_{\text{inf}}(\delta)$.

Proof. In view of condition (iv) and that $\sup_{i \in \mathcal{I}} \rho_i < \infty$, $\inf_{i \in \mathcal{I}} \delta_i > 0$, and $\inf_{i \in \mathcal{I}} \mu_i > \lambda$, we can choose a positive constant c such that

$$\rho_i e^{-(\mu_i - \lambda)\delta_i} < 1, \quad -\mu_i + 1/c + \lambda < 0, \quad c\rho_i e^{-\mu_i\delta_i} + \rho_i/\mu_i < c,$$

for all $i \in \mathcal{I}$. Let x be a solution to (4.1.3), (t_k, i_k, j_k) be the corresponding impulsive and switching signal, and $w(t)$ a given input function. Set $v_1(t) = V_1^{i_k}(t, x(t))$, $v_2(t) =$

$V_2^{ik}(t, x_t)$, and $v(t) = v_1(t) + v_2(t)$, for $t \in [t_k, t_{k+1})$ and $k \in \mathcal{Z}^+$. It is clear that $v(t)$ defines a right-continuous function on $[t_0, \infty)$. We shall show that

$$\begin{aligned} v(t)e^{\lambda(t-t_0)} &\leq \alpha(\|\xi\|) + ce^{\lambda(t-t_0)}\chi\left(\sup_{t_0 \leq s \leq t} |w(s)|\right) \\ &\quad + \sum_{t_0 < t_k \leq t} e^{\lambda(t_k-t_0)}\chi(|w(t_k^-)|), \quad t \geq t_0, \end{aligned} \quad (4.3.2)$$

where $\alpha = \alpha_2 + \alpha_3$. For convenience, write the RHS of (4.3.2) as $u(t)$ and $\bar{\chi}(t) = \chi(\sup_{t_0 \leq s \leq t} |w(s)|)$. It is clear that (4.3.2) holds for $t = t_0$. Define

$$t^* := \inf \left\{ t \in [t_0, t_1) : v(t)e^{\lambda(t-t_0)} > u(t) + \varepsilon \right\},$$

where $\varepsilon > 0$ is an arbitrarily fixed number. It is clear that $t^*(\varepsilon) = t_1$ implies

$$v(t)e^{\lambda(t-t_0)} \leq u(t) + \varepsilon,$$

for all $t \in [t_0, t_1)$. Therefore, if $t^*(\varepsilon) = t_1$ for all $\varepsilon > 0$, we must have that (4.3.2) holds on $[t_0, t_1)$. Suppose this is not the case, i.e., $t^*(\varepsilon^*) < t_1$ for some $\varepsilon^* > 0$. It follows that

$$v(t^*)e^{\lambda(t^*-t_0)} = u(t^*) + \varepsilon^* > 0,$$

which, by (4.3.2), implies that $v(t^*) > c\bar{\chi}(t^*)$. Hence condition (iii) of the theorem shows that

$$D^+[v(t^*)e^{\lambda(t^*-t_0)}] < (-\mu_{i_0} + \frac{1}{c} + \lambda)v(t^*)e^{\lambda(t^*-t_0)} < 0,$$

which clearly contradicts how t^* is chosen. Therefore, (4.3.2) holds on $[t_0, t_1)$. Now suppose that (4.3.2) is true on $[t_0, t_m)$, where $m \geq 1$. We will show that (4.3.2) holds on $[t_m, t_{m+1})$ as well. First, based on the inductive assumption, we estimate $v(t_m^-)e^{\lambda(t_m-t_0)}$. Since

$$D^+v(t) \leq -\mu_{i_{m-1}}v(t) + \chi(|w(t)|), \quad t \in [t_{m-1}, t_m),$$

we can obtain, by integration, that

$$e^{\mu_{i_{m-1}}t_m}v(t_m^-) - e^{\mu_{i_{m-1}}t_{m-1}}v(t_{m-1}) \leq \frac{1}{\mu_{i_{m-1}}}[e^{\mu_{i_{m-1}}t_m} - e^{\mu_{i_{m-1}}t_{m-1}}]\bar{\chi}(t_m^-),$$

which implies

$$v(t_m^-) \leq v(t_{m-1})e^{-\mu_{i_{m-1}}\delta_{i_{m-1}}} + \frac{1}{\mu_{i_{m-1}}}\bar{\chi}(t_m^-). \quad (4.3.3)$$

On the other hand, from (4.3.2) on $[t_0, t_m)$, we have

$$v(t_{m-1})e^{\lambda(t_{m-1}-t_0)} \leq u(t_{m-1}). \quad (4.3.4)$$

Combining (4.3.3) and (4.3.4) gives

$$\begin{aligned} v(t_m^-)e^{\lambda(t_m-t_0)} &\leq \frac{1}{\rho_{i_{m-1}}} \left[\rho_{i_{m-1}} e^{-(\mu_{i_{m-1}}-\lambda)\delta_{i_{m-1}}} \alpha(\|\xi\|) \right. \\ &\quad + \left(c\rho_{i_{m-1}} e^{-\mu_{i_{m-1}}\delta_{i_{m-1}}} + \frac{\rho_{i_{m-1}}}{\mu_{i_{m-1}}} \right) e^{\lambda(t_m-t_0)} \bar{\chi}(t_m^-) \\ &\quad \left. + \rho_{i_{m-1}} e^{-(\mu_{i_{m-1}}-\lambda)\delta_{i_{m-1}}} \sum_{t_0 < t_k \leq t_{m-1}} e^{\lambda(t_k-t_0)} \chi(|w(t_k^-)|) \right] \\ &\leq \frac{1}{\rho_{i_{m-1}}} u(t_m^-). \end{aligned}$$

Therefore, by condition (ii),

$$\begin{aligned} v(t_m)e^{\lambda(t_m-t_0)} &\leq [\rho_{i_{m-1}} v(t_m^-) + \chi(|w(t_m^-)|)] e^{\lambda(t_m-t_0)} \\ &\leq u(t_m^-) + e^{\lambda(t_m-t_0)} \chi(|w(t_m^-)|) = u(t_m), \end{aligned}$$

i.e., (4.3.2) holds for $t = t_m$. Applying the argument used to show (4.3.2) on $[t_0, t_1)$, we can prove that (4.3.2) is true on $[t_m, t_{m+1})$. By induction, (4.3.2) is true for all $t \geq t_0$. Rewrite (4.3.2) as

$$v(t) \leq \alpha(\|\xi\|)e^{-\lambda(t-t_0)} + c\chi\left(\sup_{t_0 \leq s \leq t} |w(s)|\right) + \sum_{t_0 < t_k \leq t} e^{-\lambda(t-t_k)} \chi(|w(t_k^-)|).$$

Note that

$$\begin{aligned} \sum_{t_0 < t_k \leq t} e^{-\lambda(t-t_k)} \chi(|w(t_k^-)|) &\leq \chi\left(\sup_{t_0 \leq s \leq t} |w(s)|\right) \sum_{t_0 < t_k \leq t} e^{-\lambda(t-t_k)} \\ &\leq \frac{1}{1 - e^{-\lambda\delta}} \chi\left(\sup_{t_0 \leq s \leq t} |w(s)|\right). \end{aligned}$$

We have

$$\alpha_1(x(t)) \leq v(t) \leq \alpha(\|\xi\|)e^{-\lambda(t-t_0)} + \left[c + \frac{1}{1 - e^{-\lambda\delta}} \right] \chi\left(\sup_{t_0 \leq s \leq t} |w(s)|\right).$$

Since this estimate is independent of a particular impulsive and switching signal, it follows from a standard argument that there exist functions β and γ , still independent of a particular

impulsive and switching signal, such that the estimate in Definition 4.3.1 for $x(t)$ holds, which implies uniform ISS of (4.1.3). The above estimate also establishes boundedness of the state, which further implies global existence of solutions (see [9]). The proof is complete. \square

Remark 4.3.1 Theorem 4.3.1 is sufficiently general to cover the situation that the index sets \mathcal{I} and \mathcal{J} are infinite sets. If \mathcal{I} is a finite index set, then $\sup_{i \in \mathcal{I}} \rho_i < \infty$, $\inf_{i \in \mathcal{I}} \delta_i > 0$, and $\inf_{i \in \mathcal{I}} \mu_i > \lambda$ are trivially satisfied in view of the theorem conditions. Moreover, condition (iv) can be replaced by a simpler one $\ln \rho_i < \mu_i \delta_i$, since $\lambda > 0$ can be chosen to be sufficiently small such that condition (iv) holds. \square

Remark 4.3.2 Condition (iii) in Theorem 4.3.1 implies that each of the continuous dynamics is ISS (see [151]). Nevertheless, condition (ii) does not rule out that each of the discrete dynamics can be destabilizing ($\rho_i \geq 1$). Theorem 4.3.1 shows that system (4.1.3) is ISS, if it satisfies a dwell-time lower bound condition given by condition (iv). In other words, if the impulses and switching occur not too frequently, the ISS properties of a hybrid time-delay system with stable continuous dynamics can be retained despite the destabilizing impulses. \square

Remark 4.3.3 Condition (ii) not only imposes a condition on the impulse functions I_j , it also characterizes possible jumps in the values of the multiple Lyapunov functionals V_i at the impulsive and switching times. Actually, even if there are no impulses, a comparison factor among the multiple Lyapunov functions is necessary for the average dwell-time approach to the stability analysis of switched systems (see, e.g., [107] and [174], and the factor $\mu \geq 1$ in their results). \square

Remark 4.3.4 The positive constant λ plays a role in characterizing the ISS/iISS properties with a “stability margin” (similar to stability margin of linear systems). This is similar to the generalized concept of $e^{\lambda t}$ -weighted ISS/iISS properties, introduced in [174]. \square

The second result is concerned with ISS properties of system (4.1.3), in the case when all the subsystems governing the continuous dynamics of (4.1.3) can be unstable and the impulses, on the other hand, are stabilizing. Intuitively, the conditions in the following theorem consist of four aspects (corresponding to each of the conditions): **(i)** the Lyapunov functionals satisfy certain positive definite and decrescent conditions; **(ii)** the jumps induced by the stabilizing impulses satisfy certain diminishing conditions; **(iii)** there exist some

positive estimates of the upper right-hand derivatives of the functionals with respect to each unstable mode of (4.1.3); and (iv) the estimates on the derivatives and the growth by jumps satisfy certain balancing conditions in terms of the dwell-time upper bounds.

Theorem 4.3.2 *Suppose that there exist a family of functions $\{V_1^i : i \in \mathcal{I}\}$ of class v_1 and a family of functionals $\{V_2^i : i \in \mathcal{I}\}$ of class v_2 , functions $\alpha_1, \alpha_2, \alpha_3, \chi$ of class \mathcal{K}_∞ , positive constants $\rho_i < 1, \lambda, \delta_i, \kappa_i$, and μ_i ($i \in \mathcal{I}$) such that, for all $i, \tilde{i} \in \mathcal{I}, j \in \mathcal{J}, t \in \mathcal{R}^+, x \in \mathcal{R}^n, y \in \mathcal{R}^m$, and $\phi \in \mathcal{PC}$,*

$$(i) \alpha_1(|x|) \leq V_1^i(t, x) \leq \alpha_2(|x|) \text{ and } 0 \leq V_2^i(t, \phi) \leq \alpha_3(\|\phi\|);$$

$$(ii) V_1^i(t, \phi(0) + I_j(t, \phi, y)) \leq \rho_i V_1^{\tilde{i}}(t^-, \phi(0)) + \chi(|y|) \text{ and } V_2^i(t, \phi) \leq \kappa_i \sup_{-r \leq s \leq 0} V_1^{\tilde{i}}(t + s, \phi(s));$$

$$(iii) D^+ V_i(t, \phi) \leq \mu_i V_i(t, \phi) + \chi(|w(t)|), \text{ where } V_i(t, \phi) = V_1^i(t, \phi(0)) + V_2^i(t, \phi);$$

$$(iv) \ln \bar{\rho}_i < -(\mu_i + \lambda)\delta_i, \text{ where } \bar{\rho}_i = \rho_i + \kappa_i e^{\lambda r}.$$

Moreover, suppose that $\sup_{i \in \mathcal{I}} \delta_i < \infty, \delta = \inf_{i \in \mathcal{I}} \delta_i > 0$, and $\sup_{i \in \mathcal{I}} \mu_i < \infty$. Then system (4.1.3) is uniformly ISS over $\bigcap_{i \in \mathcal{I}} \mathcal{S}_{\text{sup}}^i(\delta_i)$. In particular, system (4.1.3) is uniformly ISS over $\mathcal{S}_{\text{sup}}(\delta)$.

Proof. Let $v(t)$ and $\bar{\chi}(t)$ be the same as in the proof for Theorem 4.3.1. In view of condition (iv) and that $\sup_{i \in \mathcal{I}} \rho_i < \infty$ and $\sup_{i \in \mathcal{I}} \mu_i < \infty$, we can choose positive constants M, c_1 , and c_2 such that

$$M \geq e^{\mu_i \delta_i}, \quad \bar{\rho}_i e^{\mu_i \delta_i} c_1 + \mu_i e^{\mu_i \delta_i} < c_1, \quad c_2 \geq e^{(\mu_i + \lambda)\delta_i}, \quad \bar{\rho}_i e^{(\mu_i + \lambda)\delta_i} < 1.$$

We shall show that

$$v(t) e^{\lambda(t-t_0)} \leq M \alpha(\|\xi\|) + c_1 e^{\lambda(t-t_0)} \bar{\chi}(t) + c_2 \sum_{t_0 < t_k \leq t} e^{\lambda(t_k-t_0)} \chi(|w(t_k^-)|), \quad (4.3.5)$$

for $t \geq t_0$, where $\alpha = \alpha_2 + \alpha_3$. For convenience, let $u(t)$ denote the RHS of (4.3.5). For $k \in \mathcal{Z}^+$, condition (iii) on $[t_k, t_{k+1})$ implies that

$$e^{-\mu_{i_k} t} v(t) - e^{-\mu_{i_k} t_k} v(t_k) \leq \int_{t_k}^t e^{-\mu_{i_k} s} \chi(|w(s)|) ds, \quad t \in [t_k, t_{k+1}),$$

which gives

$$v(t) \leq v(t_k) e^{\mu_{i_k}(t-t_k)} + \mu_{i_k} e^{\mu_{i_k} \delta_{i_k}} \bar{\chi}(t), \quad (4.3.6)$$

for $t \in [t_k, t_{k+1})$ and $k \in \mathcal{Z}^+$. Note that (4.3.6) implies (4.3.5) on $[t_0, t_1)$. Now suppose that (4.3.5) is true on $[t_0, t_m)$. We will show that (4.3.5) holds on $[t_m, t_{m+1})$ as well. By condition (ii), the inductive assumption, and the continuity of v_2 at $t = t_m$,

$$\begin{aligned} v(t_m) &\leq \rho_{i_m} v_1(t_m^-) + \chi(|w(t_m^-)|) + v_2(t_m^-) \\ &\leq \rho_{i_m} u(t_m^-) e^{-\lambda(t_m - t_0)} + \kappa_{i_m} \sup_{-r \leq s < 0} |v_1(t_m + s)| + \chi(|w(t_m^-)|) \\ &\leq \bar{\rho}_{i_m} u(t_m^-) e^{-\lambda(t_m - t_0)} + \chi(|w(t_m^-)|). \end{aligned} \quad (4.3.7)$$

Applying (4.3.6) on $[t_m, t_{m+1})$ and by (4.3.7), we have, for $t \in [t_m, t_{m+1})$,

$$\begin{aligned} v(t) e^{\lambda(t - t_0)} &\leq \bar{\rho}_{i_m} e^{(\mu_{i_m} + \lambda)\delta_{i_m}} M \alpha(\|\phi\|) + [\bar{\rho}_{i_m} e^{\mu_{i_m}\delta_{i_m}} c_1 + \mu_{i_m} e^{\mu_{i_m}\delta_{i_m}}] e^{\lambda(t - t_0)} \bar{\chi}(t) \\ &\quad + \bar{\rho}_{i_m} e^{(\mu_{i_m} + \lambda)\delta_{i_m}} c_2 \sum_{t_0 < t_k \leq t_{m-1}} e^{\lambda(t_k - t_0)} \chi(|w(t_k^-)|) \\ &\quad + e^{(\mu_{i_m} + \lambda)\delta_{i_m}} e^{\lambda(t_m - t_0)} \chi(|w(t_m^-)|) \\ &\leq u(t), \end{aligned}$$

i.e., (4.3.5) holds on $[t_m, t_{m+1})$. Hence, by induction, (4.3.5) is true for all $t \geq t_0$. The rest of the proof is the same as that of Theorem 4.3.1. The proof is complete. \square

The following corollary is an immediate consequence of Theorem 4.3.2 and gives alternative sufficient conditions for ISS of system (4.1.3).

Corollary 4.3.1 *Suppose that there exist positive constants $\alpha_1, \alpha_2, \alpha_3$, and p such that conditions (i), (ii), and (iv) in Theorem 4.3.2 are replaced by the following*

$$(i') \quad \alpha_1 |x|^p \leq V_1^i(t, x) \leq \alpha_2 |x|^p \quad \text{and} \quad 0 \leq V_2^i(t, \phi) \leq \alpha_3 \|\phi\|^p;$$

$$(ii') \quad V_1^i(t, \phi(0) + I_j(t, \phi, y)) \leq \rho_i V_1^{\bar{i}}(t^-, \phi(0)) + \chi(|y|);$$

$$(iv') \quad \ln \bar{\rho}_i < -(\mu_i + \lambda)\delta_i, \quad \text{where} \quad \bar{\rho}_i = \rho_i + \frac{\alpha_3}{\alpha_1} e^{\lambda r},$$

and condition (iii) and all other assumptions remain the same. Then the same conclusions hold as in Theorem 4.3.2.

Proof. It suffices to verify that condition (ii) in Theorem 4.3.2 is satisfied with $\kappa_i = \frac{\alpha_3}{\alpha_1}$. \square

Remark 4.3.5 If \mathcal{I} is a finite index set, then $\sup_{i \in \mathcal{I}} \delta_i < \infty$, $\inf_{i \in \mathcal{I}} \delta_i > 0$, and $\sup_{i \in \mathcal{I}} \mu_i < \infty$ are trivially satisfied in view of the theorem conditions, and, moreover, condition (iv) can be replaced by a simpler one $\ln(\rho_i + \kappa_i) < -\mu_i \delta_i$, since $\lambda > 0$ can be chosen to be sufficiently small such that condition (iv) holds. \square

Remark 4.3.6 Condition (iii) in Theorem 4.3.2 implies that each of the continuous dynamics can be unstable ($\mu_i > 0$). Nevertheless, condition (ii) implies that each of the discrete dynamics is stabilizing ($\rho_i < 1$). Theorem 4.3.2 shows that system (4.1.3) is ISS, if it satisfies a dwell-time upper bound condition given by condition (iv). In other words, if the impulses are applied sufficiently frequently, a hybrid time-delay system with unstable continuous dynamics can be impulsively stabilized in the ISS/iISS sense. \square

Remark 4.3.7 Condition (ii) characterizes the key distinction of the idea of impulsive stabilization of time-delay systems using the method of Lyapunov functionals. According to condition (ii), it is only required that the function part of V_i (i.e., V_1^i) is stabilized by the impulses, which is reasonable, since we cannot expect an impulse that occurs at a discrete time to bring the value of a purely functional part of V_i (e.g., an integral of ϕ) down. The factor κ_i plays a role in estimating the functional part of V_i in terms of V_i^j with memory (Corollary 4.3.1 gives such an example), which eventually leads to condition (iv), where the dwell-time conditions are given depending on the delay size r and the factor κ_i . It appears that the delay size r and the factor κ_i have to be sufficiently small such that $\rho_i + \kappa_i e^{\lambda r} < 1$ (implied by condition (iv)). However, as we can see from the examples in the next section, we can always add a tuning parameter as the coefficient of V_2^i and hence make κ_i sufficiently small (of course, by doing so, more burden is going to be placed on V_1^i and the estimates μ_i in condition (iii) can become larger, which eventually leads to more restrictions on δ_i). The restriction on the delay size r can also be resolved using this technique. It is therefore remarked that Theorem 4.3.2 can be applied to system (4.1.3) with arbitrarily large delays, whereas the results in [36] and [115] both have restrictions on the delay size. \square

Remark 4.3.8 Theorems 4.3.1 and 4.3.2 each provide a set of sufficient Lyapunov conditions to check for ISS properties of an impulsive and switching hybrid time-delay system. Therefore, the construction of Lyapunov functionals are crucial in applying these results. Although no universal rules exist on how to construct these functionals, there are some guidelines on how to choose them. As for Lyapunov functionals for linear time-delay systems, there are some commonly used candidates to perform stability analysis of such

systems, as summarized in the survey paper [155]. It can be seen that these functionals usually consist of two parts, a function part, which can be a quadratic function, and a functional part, which is usually an integral whose form varies depending on the right-hand sides of the systems being studied. These guidelines are well demonstrated by the examples to be presented in Section 4.3.4. Under these guidelines, and with the help of linear or non-linear feedback controllers, hopefully one can find suitable Lyapunov functionals that can satisfy all the conditions for ISS/iISS in Theorems 4.3.1 and 4.3.2. Moreover, conditions in Theorems 4.3.1 and 4.3.2 are only sufficient conditions for ISS/iISS of the impulsive and switching hybrid time-delay systems being investigated. Whether these conditions are necessary or what are the necessary conditions for ISS/iISS of such systems remains an interesting problem to be investigated. \square

4.3.3 Integral Input-to-State Stability

As shown in [163], iISS is a weaker notion than that of ISS and can be characterized by a weaker Lyapunov condition. In a similar spirit, the following two theorems on iISS of system (4.1.3) are formulated with a weaker condition on continuous dynamics.

Theorem 4.3.3 *If all the conditions in Theorem 4.3.1 hold, except that condition (iii) is replaced by*

$$(iii') \quad D^+ V_i(t, \phi) \leq (\chi(|w(t)|) - \mu_i) V_i(t, \phi) + \chi(|w(t)|),$$

then system (4.1.3) is uniformly iISS over $\bigcap_{i \in \mathcal{I}} \mathcal{S}_{\text{inf}}^i(\delta_i)$. In particular, (4.1.3) is uniformly iISS over $\mathcal{S}_{\text{inf}}(\delta)$.

Proof. Choose a positive constant c such that

$$\rho e^{(-\mu_i + \lambda)\delta_i} < 1, \quad 1 < c\rho e^{-\mu_i\delta_i} + \rho_i < c, \quad \forall i \in \mathcal{I}.$$

Instead of showing (4.3.2), we prove that

$$\begin{aligned} v(t) e^{\lambda(t-t_0)} &\leq \mathcal{E}(t, t_0) [\alpha(\|\xi\|) + c e^{\lambda(t-t_0)} \int_{t_0}^t \chi(|w(s)|) ds] \\ &\quad + \sum_{t_0 < t_k \leq t} e^{\lambda(t_k - t_0)} \chi(|w(t_k^-)|), \quad t \geq t_0, \end{aligned} \quad (4.3.8)$$

where $\alpha = \alpha_2 + \alpha_3$ and $\mathcal{E}(t, s)$, for $t \geq s \geq t_0$, is defined by

$$\mathcal{E}(t, s) = \exp \left(\int_s^t \chi(|w(s)|) ds \right).$$

As usual, we let $u(t)$ denote the RHS of (4.3.8). For $k \geq 1$, condition (iii') on $[t_{k-1}, t_k)$ implies that

$$\begin{aligned} & e^{-\int_{t_{k-1}}^t \chi(|w(s)|) ds + \mu_{i_{k-1}} t} v(t) - e^{\mu_{i_{k-1}} t_{k-1}} v(t_{k-1}) \\ & \leq \int_{t_{k-1}}^t e^{-\int_{t_{k-1}}^s \chi(|w(\tau)|) d\tau + \mu_{i_{k-1}} s} \chi(|w(s)|) ds, \quad t \in [t_{k-1}, t_k), \end{aligned}$$

which gives

$$v(t) \leq \mathcal{E}(t, t_{k-1}) \left[v(t_{k-1}) e^{-\mu_{i_{k-1}}(t-t_{k-1})} + \int_{t_{k-1}}^t \chi(|w(s)|) ds \right], \quad (4.3.9)$$

for $t \in [t_{k-1}, t_k)$ and $k \geq 1$. Note that (4.3.9) implies (4.3.8) on $[t_0, t_1)$. Now suppose that (4.3.8) is true on $[t_0, t_m)$, where $m \geq 1$. We will show that (4.3.8) holds on $[t_m, t_{m+1})$ as well. First, based on the inductive assumption, we estimate $v(t_m^-) e^{\lambda(t_m-t_0)}$. Applying (4.3.9) on $[t_{m-1}, t_m)$ gives

$$v(t_m^-) \leq \mathcal{E}(t_m, t_{m-1}) \left[v(t_{m-1}) e^{-\mu_{i_{m-1}}(t_m-t_{m-1})} + \int_{t_{m-1}}^{t_m} \chi(|w(s)|) ds \right]. \quad (4.3.10)$$

Moreover, by (4.3.8) on $[t_0, t_m)$, $v(t_{m-1}) e^{\lambda(t_{m-1}-t_0)} \leq u(t_{m-1})$. Combining this and (4.3.10) gives

$$\begin{aligned} v(t_m^-) e^{\lambda(t_m-t_0)} & \leq \frac{1}{\rho_{i_{m-1}}} \left\{ \rho_{i_{m-1}} e^{-(\mu_{i_{m-1}}-\lambda)\delta_{i_{m-1}}} \mathcal{E}(t_m, t_0) \alpha(\|\xi\|) \right. \\ & \quad + \left(c \rho_{i_{m-1}} e^{-\mu_{i_{m-1}}\delta_{i_{m-1}}} + \rho_{i_{m-1}} \right) \mathcal{E}(t_m, t_0) e^{\lambda(t_m-t_0)} \int_{t_0}^{t_m} \chi(|w(s)|) ds \\ & \quad \left. + \rho_{i_{m-1}} e^{-(\mu_{i_{m-1}}-\lambda)\delta_{i_{m-1}}} \sum_{t_0 < t_k \leq t_{m-1}} e^{\lambda(t_k-t_0)} \chi(|w(t_k^-)|) \right\} \\ & \leq \frac{1}{\rho_{i_{m-1}}} u(t_m^-), \end{aligned}$$

where the relation $\mathcal{E}(t, s) = \mathcal{E}(t, \tau) \mathcal{E}(\tau, s)$, for $t \geq \tau \geq s$, are used. Therefore, by condition (ii),

$$\begin{aligned} v(t_m) e^{\lambda(t_m-t_0)} & \leq \left[\rho_{i_{m-1}} v(t_m^-) + \chi(|w(t_m^-)|) \right] e^{\lambda(t_m-t_0)} \\ & \leq u(t_m^-) + e^{\lambda(t_m-t_0)} \chi(|w(t_m^-)|) = u(t_m). \end{aligned} \quad (4.3.11)$$

Applying (4.3.9) on $[t_m, t_{m+1})$ and using (4.3.11), we obtain

$$\begin{aligned} v(t)e^{\lambda(t-t_0)} &\leq e^{-(\mu_{im}-\lambda)(t-t_m)} \mathcal{E}(t, t_0) \alpha(\|\xi\|) \\ &\quad + \mathcal{E}(t, t_0) \left(ce^{-\mu_{im}(t-t_m)} e^{\lambda(t_m-t_0)} \int_{t_0}^{t_m} \chi(|w(s)|) ds + e^{\lambda(t-t_0)} \int_{t_m}^t \chi(|w(s)|) ds \right) \\ &\quad + e^{-(\mu_{im}-\lambda)(t-t_m)} \sum_{t_0 < t_k \leq t} e^{\lambda(t_k-t_0)} \chi(|w(t_k^-)|) \\ &\leq u(t), \quad t \in [t_m, t_{m+1}). \end{aligned}$$

i.e., (4.3.2) is true on $[t_m, t_{m+1})$. By induction, (4.3.2) is true for all $t \geq t_0$. To show uniform iISS of (4.1.3), note that

$$\begin{aligned} \mathcal{E}(t, t_0) \alpha(\|\xi\|) &= \alpha(\|\xi\|) + (\mathcal{E}(t, t_0) - 1) \alpha(\|\xi\|) \\ &\leq \alpha(\|\xi\|) + \frac{1}{2} \alpha^2(\|\xi\|) + \frac{1}{2} [\mathcal{E}(t, t_0) - 1]^2. \end{aligned} \quad (4.3.12)$$

Define $\vartheta_1(r) = r + \frac{r^2}{2}$ and $\vartheta_2(r) = \frac{1}{2}(e^r - 1)^2 + re^r, r \geq 0$. It is clear that ϑ_1 and ϑ_2 are both of class \mathcal{K}_∞ . Applying (4.3.12) to (4.3.8), we obtain

$$v(t) \leq \vartheta_1(\alpha(\|\xi\|)) + \vartheta_2\left(\int_{t_0}^t \chi(|w(s)|) ds\right) + \sum_{t_0 < t_k \leq t} e^{\lambda(t_k-t_0)} \chi(|w(t_k^-)|).$$

Uniform iISS of (4.1.3) follows from the previous inequality by a standard argument, and global existence of solutions follows from the boundedness of the state (see [9]). The proof is complete. \square

Since condition (iii') in Theorem 4.3.3 is weaker than condition (iii) in Theorem 4.3.1, the following is an immediate consequence of Theorem 4.3.3.

Corollary 4.3.2 *Under the same conditions as in Theorem 4.3.1, system (4.1.3) is uniformly iISS over $\bigcap_{i \in \mathcal{I}} \mathcal{S}_{\text{inf}}^i(\delta_i)$ and $\mathcal{S}_{\text{inf}}(\delta)$.*

Theorem 4.3.4 *If all the conditions in Theorem 4.3.2 hold, except that condition (iii) is replaced by*

$$(iii'') \quad D^+ V_i(t, \phi) \leq (\chi(|w(t)|) + \mu) V_i(t, \phi) + \chi(|w(t)|),$$

then system (4.1.3) is uniformly iISS over $\bigcap_{i \in \mathcal{I}} \mathcal{S}_{\text{sup}}^i(\delta_i)$. In particular, system (4.1.3) is uniformly iISS over $\mathcal{S}_{\text{sup}}(\delta)$.

Proof. Instead of showing (4.3.5), we can show that

$$v(t)e^{\lambda(t-t_0)} \leq \mathcal{E}(t, t_0) \left[M\alpha \|\xi\|^p + c_1 e^{\lambda(t-t_0)} \int_{t_0}^t \chi(|w(s)|) ds \right] \\ + c_2 \sum_{t_0 < t_k \leq t} e^{\lambda(t_k-t_0)} \chi(|w(t_k^-)|), \quad t \geq t_0,$$

where $\mathcal{E}(t, t_0)$ is defined as in the proof of Theorem 4.3.3 and the constants are chosen as in the proof of Theorem 4.3.2. The proof can be completed by induction and the argument is similar to that in the proof of Theorem 4.3.2. The details are omitted. \square

Since condition (iii^{''}) in Theorem 4.3.4 is weaker than condition (iii) in Theorem 4.3.2, the following is an immediate consequence of Theorem 4.3.4.

Corollary 4.3.3 *Under the same conditions as in Theorem 4.3.2, system (4.1.3) is uniformly iISS over $\bigcap_{i \in \mathcal{I}} \mathcal{S}_{\text{sup}}^i(\delta_i)$ and $\mathcal{S}_{\text{sup}}(\delta)$.*

4.3.4 Examples

In this section, we present several examples to illustrate our main results.

Example 4.3.1 Consider the following nonlinear impulsive switched delay system

$$\begin{cases} x'(t) = -\text{sat}(x(t)) + a_{i_k} \text{sat}(x(t - \tau)) + b_{i_k} \text{sat}(w(t)), & t \in (t_k, t_{k+1}), & (4.3.13a) \\ \Delta x(t) = c_{j_k} \text{sat}(w(t^-)), & t = t_k, & (4.3.13b) \end{cases}$$

where $a_{i_k}, b_{i_k} \in \{-0.2, -0.1, 0.1, 0.2\}$, $c_{j_k} \in [-\frac{1}{2}, \frac{1}{2}]$, and $\text{sat}(x)$ is a saturation function defined by $\text{sat}(x) = \frac{1}{2}(|x+1| - |x-1|)$.

To investigate the ISS properties of (4.3.13), let $\mathcal{I} \triangleq \{1, 2, 3, 4\}$ and $\mathcal{J} \triangleq [-\frac{1}{2}, \frac{1}{2}]$. For $i \in \mathcal{I}$ and $j \in \mathcal{J}$, let $[a_1 \ a_2 \ a_3 \ a_4] = [b_1 \ b_2 \ b_3 \ b_4] = [-0.2 \ -0.1 \ 0.1 \ 0.2]$ and $c_j = j$. Choose Lyapunov functionals $V_i(t, \phi) = V_1^i(t, \phi(0)) + V_2^i(t, \phi)$, with

$$V_1^i(t, x) = \begin{cases} x^2, & |x| \leq 1, \\ e^{2(|x|-1)}, & |x| > 1, \end{cases}$$

and

$$V_2^i(t, \phi) = |a_i| \int_{-r}^0 \text{sat}^2(\phi(s)) \left[\kappa + 1 + \frac{\kappa s}{r} \right] ds,$$

where $\kappa > 0$. Condition (i) of Theorem 4.3.1 is clearly satisfied. Next we verify condition (ii) of Theorem 4.3.1. For $|\phi(0) + I_j(t, \phi, y)| \leq 1$,

$$V_1^{\tilde{i}}(t, \phi(0) + I_j(t, \phi, y)) = [\phi(0) + j\text{sat}(y)]^2 \leq 2\phi^2(0) + \frac{1}{2}y^2 \leq 2V_1^i(t, \phi(0)) + \frac{1}{2}y^2.$$

For $|\phi(0) + I_j(t, \phi, y)| > 1$, it is implied that $|\phi(0)| > \frac{1}{2}$. We have

$$\begin{aligned} V_1^{\tilde{i}}(t, \phi(0) + I_j(t, \phi, y)) &= e^{2|\phi(0)+j\text{sat}(y)|-2} \leq e^{2|\phi(0)|-1} \\ &\leq \begin{cases} ee^{2(|\phi(0)|-1)} = eV_1^i(t, \phi(0)), & |\phi(0)| > 1, \\ 2e|\phi(0)|^2 = 2eV_1^i(t, \phi(0)), & |\phi(0)| \in (\frac{1}{2}, 1], \end{cases} \end{aligned}$$

where the fact that $2x^2 > e^{2(x-1)}$, for $x \in (\frac{1}{2}, 1]$, is used. Moreover, $V_2^{\tilde{i}}(t, \phi) \leq 2V_2^i(t, \phi)$.

In either case, condition (ii) is verified with $\rho_i \equiv 2e$. Now we check condition (iv). If $|\phi(0)| \leq 1$, we have

$$\begin{aligned} D^+ V_i(t, \phi) &= 2\phi(0) [-\text{sat}(\phi(0)) + a_i\text{sat}(\phi(-r)) + b_i\text{sat}(w(t))] \\ &\quad + |a_i|(\kappa + 1)\text{sat}^2(\phi(0)) - |a_i|\text{sat}^2(\phi(-r)) - \frac{\kappa}{r}|a_i| \int_{-r}^0 \text{sat}^2(\phi(s))ds \\ &\leq -(2 - |a_i|(\kappa + 2) - 2|b_i|)V_1^i(t, \phi(0)) - \frac{\kappa}{(\kappa + 1)r}V_2^i(t, \phi) + \frac{|b_i|}{2}y^2 \\ &\leq -\min \left\{ (2 - |a_i|(\kappa + 2) - 2|b_i|), \frac{\kappa}{(\kappa + 1)r} \right\} V_i(t, \phi) + \frac{|b_i|}{2}y^2. \end{aligned}$$

If $|\phi(0)| > 1$, we have

$$\begin{aligned} D^+ V_i(t, \phi) &= 2e^{2(|\phi(0)|-1)} \text{sgn}(\phi(0)) [-\text{sat}(\phi(0)) + a_i\text{sat}(\phi(-r)) + b_i\text{sat}(w(t))] \\ &\quad + |a_i|(\kappa + 1)\text{sat}^2(\phi(0)) - |a_i|\text{sat}^2(\phi(-r)) - \frac{\kappa}{r}|a_i| \int_{-r}^0 \text{sat}^2(\phi(s))ds \\ &\leq -2e^{2(|\phi(0)|-1)}(1 - |b_i|)V_i(t, \phi) + |a_i| [2e^{2(|\phi(0)|-1)} |\text{sat}(\phi(-r))| \\ &\quad - \text{sat}^2(\phi(-r)) + (\kappa + 1)] \\ &\leq -(2 - |a_i|(\kappa + 2) - 2|b_i|)V_1^i(t, \phi(0)) - \frac{\kappa}{(\kappa + 1)r}V_2^i(t, \phi) \\ &\leq -\min \left\{ (2 - |a_i|(\kappa + 2) - 2|b_i|), \frac{\kappa}{(\kappa + 1)r} \right\} V_i(t, \phi), \end{aligned}$$

where, to derive the second inequality above, we have used the fact that $-x^2 + 2bx + (\kappa + 1) \leq 2b + \kappa \leq b(\kappa + 2)$, for $x \in [0, 1]$, $b \geq 1$, and $\kappa > 0$. Therefore, taking

$$\mu_i = -\min \left\{ (2 - |a_i|(\kappa + 2) - 2|b_i|), \frac{\kappa}{(\kappa + 1)r} \right\}, \quad (4.3.14)$$

condition (iii) of Theorem 4.3.1 is satisfied, provided that $2 - |a_i|(\kappa + 2) - 2|b_i| > 0$ for all $i \in \mathcal{I}$. According to Theorem 4.3.1 (and Remark 4.3.1), if $\delta_i > \frac{1+\ln 2}{\mu_i}$ for all $i \in \mathcal{I}$, then system (4.3.13) is uniformly ISS over $\bigcap_{i \in \mathcal{I}} \mathcal{S}_{\text{inf}}^i(\delta_i)$. For illustration, choosing $\kappa = 0.2$ and $r = 0.1$, we can compute from (4.3.14) that $\mu_1 = \mu_4 = 1.16$ and $\mu_2 = \mu_3 = 1.58$, which gives dwell-time conditions $\delta_1 = \delta_4 > 1.4596$ and $\delta_2 = \delta_3 > 1.0716$. Simulation results for system (4.3.13) with these parameters are shown in Figure 4.1. \square

Next, we apply Theorems 4.3.3 and 4.3.4 to study integral input-to-state stability of a bilinear impulsive switched delay system.

Example 4.3.2 Consider the following bilinear impulsive switched delay system

$$\begin{cases} x'(t) = A_{i_k}x(t) + \sum_{p=1}^m w_p(t)(A_p^{i_k}x(t) + B_p^{i_k}x(t-r)) \\ \quad + C_{i_k}w(t), \quad t \in (t_k, t_{k+1}), \\ \Delta x(t) = D_{j_k}x(t^-) + E_{j_k}w(t^-), \quad t = t_k, \end{cases} \quad (4.3.15a)$$

$$(4.3.15b)$$

where $i_k \in \mathcal{I}$, $j_k \in \mathcal{J}$, and both \mathcal{I} and \mathcal{J} are finite index sets. For each $i \in \mathcal{I}$ and $j \in \mathcal{J}$, $p = 1, 2, \dots, m$, A_i , A_p^i , B_p^i , and D_j are in $\mathcal{R}^{n \times n}$, and C_i and E_j are in $\mathcal{R}^{n \times m}$. The input function w is in \mathcal{R}^m and its components are $w_p, p = 1, 2, \dots, m$.

The ISS properties of (4.3.15) obtained by Theorems 4.3.3 and 4.3.4 are summarized in the following proposition.

Proposition 4.3.1 *If*

- (i) *all A_i are Hurwitz and P_i are positive definite matrices such that $A_i^T P_i + P_i A_i = -I$ and there exist triples of positive numbers $(\mu_i, \rho_i, \delta_i)$, $i \in \mathcal{I}$, such that $\delta_i > \frac{\ln \rho_i}{\mu_i} \geq 0$ and*

$$\begin{aligned} 0 < \mu_i < \min \left\{ \frac{1}{\lambda_{\max}(P_i)}, \frac{1}{2r} \right\}, \\ \rho_i > \max_{j \in \mathcal{J}, \tilde{i} \in \mathcal{I}} \lambda_{\max} \left(P_i^{-1}(\mathcal{I}_n + D_j)^T P_{\tilde{i}}(\mathcal{I}_n + D_j) \right), \end{aligned} \quad (4.3.16)$$

for all $i \in \mathcal{I}$, where \mathcal{I}_n denotes the $n \times n$ identity matrix, then system (4.3.15) is uniformly i ISS over $\bigcap_{i \in \mathcal{I}} \mathcal{S}_{\text{inf}}^i(\delta_i)$. In particular, for $\delta = \max_{i \in \mathcal{I}} \delta_i$, system (4.3.15) is uniformly i ISS over $\mathcal{S}_{\text{inf}}(\delta)$.

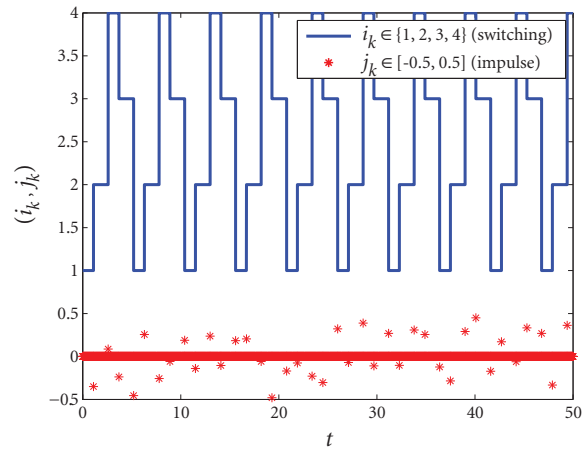

(a) An impulsive and switching signal

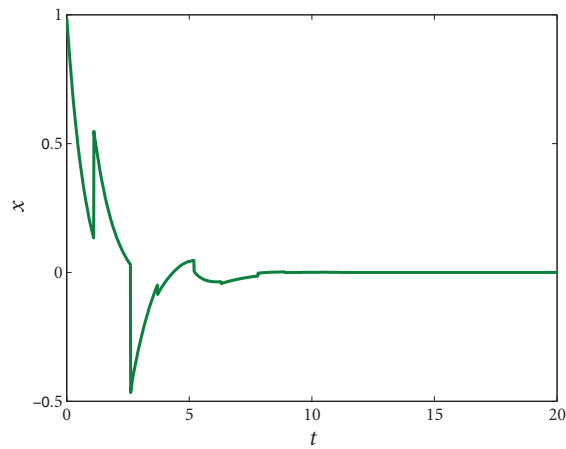

(b) System response with exponentially decaying input

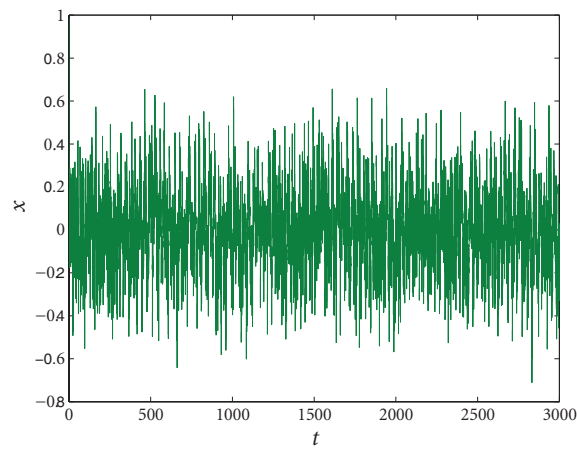

(c) System response with bounded input and random valued impulses

Figure 4.1 Simulation results for Example 4.3.1.

(ii) there exist triples of positive numbers $(\mu_i, \rho_i, \delta_i)$, $i \in \mathcal{I}$, such that all positive and

$$\begin{aligned} \delta_i &> -\frac{\ln(\rho_i)}{\mu_i}, \quad \mu_i > \lambda_{\max}(A_i^T + A_i), \\ \rho_i &> \max_{j \in \mathcal{J}} \lambda_{\max}(\mathcal{I}_n + D_j)^T (\mathcal{I}_n + D_j), \end{aligned} \quad (4.3.17)$$

for all $i \in \mathcal{I}$, then system (4.3.15) is uniformly iISS over $\bigcap_{i \in \mathcal{I}} \mathcal{S}_{\text{sup}}^i(\delta_i)$. In particular, for $\delta = \min_{i \in \mathcal{I}} \delta_i$, system (4.3.15) is uniformly iISS over $\mathcal{S}_{\text{sup}}(\delta)$.

Proof. (i) Choose $V_i(t, \phi) = V_1^i(t, \phi(0)) + V_2^i(t, \phi)$, with $V_1^i(t, x) = x^2$ and

$$V_2^i(t, \phi) = \varepsilon \int_{-r}^0 \left(2 + \frac{s}{r}\right) |\phi(0)|^2 ds,$$

where $\varepsilon \in (0, \frac{1}{3})$. We can compute that

$$\begin{aligned} D^+ V_i(t, \phi) &= 2\phi^T(0)P_i \left(A_i\phi(0) + \sum_{p=1}^m w_p(t) [A_p^i(\phi(0)) + B_p^i\phi(-r)] + C_i w(t) \right) \\ &\quad + \varepsilon \left(2|\phi(0)|^2 - |\phi(-r)|^2 - \frac{1}{r} \int_{-r}^0 |\phi(0)|^2 ds \right) \\ &\leq (\chi_\varepsilon^1(|w(t)|) - 1 + 3\varepsilon) \frac{1}{\lambda_{\max}(P_i)} V_1^i(t, \phi(0)) - \frac{1}{2r} V_2^i(t, \phi) + \chi_\varepsilon^1(|w(t)|), \end{aligned} \quad (4.3.18)$$

where χ_ε^1 is a function in \mathcal{K}_∞ which depends on ε . On the other hand, with $I_j(t, \phi, y) = D_j\phi(0) + E_j y$, we can show

$$\begin{aligned} V_1^{\tilde{i}}(t, \phi(0) + I_j(t, \phi, y)) &= [(\mathcal{I}_n + D_j)\phi(0) + E_j y]^T P_i [(\mathcal{I}_n + D_j)\phi(0) + E_j y] \\ &\leq (1 + \varepsilon) \max_{j \in \mathcal{J}, \tilde{i} \in \mathcal{I}} \lambda_{\max} \left(P_i^{-1} (\mathcal{I}_n + D_j)^T P_i (\mathcal{I}_n + D_j) \right) \\ &\quad \times V_1^i(t^-, \phi(0)) + \chi_\varepsilon^2(|y|), \end{aligned} \quad (4.3.19)$$

where χ_ε^2 is also a function in \mathcal{K}_∞ which depends on ε . In view of (4.3.16), (4.3.18), and (4.3.19), we can choose $\varepsilon > 0$ sufficiently small such that condition (ii) in Theorem 4.3.1 and condition (iii') in Theorem 4.3.3 both hold with constants μ_i and ρ_i . Since $\delta_i > \frac{\ln \rho_i}{\mu_i}$, the conclusion follows from Theorem 4.3.3.

(ii) Choose $V_i(t, \phi) = V_1^i(t, \phi(0)) + V_2^i(t, \phi)$, with $V_1^i(t, x) = x^2$ and

$$V_2^i(t, \phi) = \int_{-r}^0 |\phi(0)|^2 ds,$$

where $\varepsilon > 0$. Similar to (4.3.18) and (4.3.19), we can compute

$$D^+ V_i(t, \phi) \leq \left(\chi_\varepsilon^1(|w(t)|) + \lambda_{\max}(A_i^T + A_i) + 2\varepsilon \right) V_i(t, \phi(0)) + \chi_\varepsilon^1(|w(t)|), \quad (4.3.20)$$

and

$$\begin{aligned} V_1^{\tilde{i}}(t, \phi(0) + I_j(t, \phi, y)) &\leq (1 + \varepsilon) \max_{j \in \mathcal{J}} \lambda_{\max}(\mathcal{I}_n + D_j)^T (\mathcal{I}_n + D_j) \\ &\quad \times V_1^i(t^-, \phi(0)) + \chi_\varepsilon^2(|y|). \end{aligned} \quad (4.3.21)$$

Moreover, checking condition (ii) of Theorem 4.3.2, we have

$$V_2^i(t, \phi) \leq \varepsilon r \|\phi(s)\|^2 \leq \varepsilon r V_1^{\tilde{i}}(t + s, \phi(s)). \quad (4.3.22)$$

In view of (4.3.17), (4.3.20), (4.3.21), and (4.3.22), we can choose $\varepsilon > 0$ and $\lambda > 0$ sufficiently small such that conditions (ii) and (iv) in Theorem 4.3.2 and condition (iv) in Theorem 4.3.4 hold with constants μ_i, ρ_i, δ_i , and $\kappa_i = \varepsilon r$. The conclusion follows from that of Theorem 4.3.4. \square

Remark 4.3.9 Proposition 4.3.1 partially extends Theorem 3.10 in [151], where necessary and sufficient conditions for the iISS of a bilinear delay system are studied, to impulsive hybrid systems with time-delay. Proposition 4.3.1 also shows that, if each of the bilinear delay systems is unstable (i.e., A_i is not Hurwitz), we can still apply impulse control to achieve iISS for the hybrid time-delay system. \square

The following example presents a network based impulse control strategy to achieve ISS/iISS properties of estimation errors over a hybrid delayed system.

Example 4.3.3 Consider the following hybrid delayed networked control system

$$\begin{cases} x'(t) = A_{i_k} x(t) + f_{i_k}(x(t-r)) + B_{i_k} w(t), & t \in [t_k, t_{k+1}), \end{cases} \quad (4.3.23a)$$

$$\begin{cases} y(t) = x(t) + v(t), & t \geq t_0, \end{cases} \quad (4.3.23b)$$

$$\begin{cases} \hat{x}'(t) = A_{i_k} \hat{x}(t) + \hat{f}_{i_k}(\hat{x}(t-r)), & t \in [t_k, t_{k+1}), \end{cases} \quad (4.3.23c)$$

$$\begin{cases} \hat{x}_l(t) = \begin{cases} y_{j_k}(t^-), & l = j_k, \\ \hat{x}_l(t^-), & l \neq j_k, \end{cases} & l \in \{1, 2, \dots, n\}, \end{cases} \quad (4.3.23d)$$

where $x(t) \in \mathcal{R}^n$ is the system state, $w(t) \in \mathcal{R}^m$ is the disturbance input, $y(t) \in \mathcal{R}^n$ is the state measurement, $v(t) \in \mathcal{R}^n$ is the measurement noise, $\hat{x}(t) \in \mathcal{R}^n$ is the remote estimate

of $x(t)$, $f_i(x(t-r))$ and $\hat{f}_i(\hat{x}(t-r))$ are the nonlinear delayed perturbations of the state and their estimations, respectively, with $r > 0$ as a constant time-delay. Moreover, $i_k \in \mathcal{I}$ and \mathcal{I} is a finite index set; $\{t_k\}$ is a monotonically increasing transmission time sequence satisfying $t_k \rightarrow \infty$ as $k \rightarrow \infty$; at each transmission time $t = t_k$, a try-once-discard (TOD)-like protocol [175] to determine the index $j_k \in \{1, 2, \dots, n\}$, i.e., j_k is the index j corresponding to the largest

$$|\hat{x}_j(t_k^-) - y_j(t_k^-)| = |e_j(t_k^-) - v_j(t_k^-)|,$$

where $j \in \{1, 2, \dots, n\}$. When $t \in (t_k, t_{k+1})$, we can estimate $x(t)$ by letting $\hat{x}(t)$ evolve according to (4.3.23c); at $t = t_k$, a measurement y_{j_k} (based on a TOD-like protocol) is sent to the remote estimator and provides feedback impulse control to the estimate \hat{x}_{j_k} . The objective is to achieve ISS/iISS properties of the estimation error $E(t)$, which is defined by $E(t) = \hat{x}(t) - x(t)$ and can be shown to satisfy the following impulsive and switching hybrid delayed systems

$$\begin{cases} E'(t) = A_{i_k}E(t) + \hat{f}_{i_k}(\hat{x}(t-r)) - f_{i_k}(x(t-r)) - B_{i_k}w(t), & t \in [t_k, t_{k+1}), & (4.3.24a) \\ \hat{E}_l(t) = \begin{cases} v_{j_k}(t^-), & l = j_k, \\ \hat{E}_l(t^-), & l \neq j_k, \end{cases} & l \in \{1, 2, \dots, n\}. & (4.3.24b) \end{cases}$$

It is assumed that there exist positive constants L_i ($i \in \mathcal{I}$) such that

$$|f_i(x) - \hat{f}_i(\hat{x})| \leq L_i |x - \hat{x}|, \quad \forall x, \hat{x} \in \mathcal{R}^n, \quad i \in \mathcal{I}. \quad (4.3.25)$$

To investigate the ISS properties of (4.3.24), choose Lyapunov functionals $V_i(t, \phi) = V_1^i(t, \phi(0)) + V_2^i(t, \phi)$, with $V_1^i(t, E) = E^2$ and $V_2^i(t, \phi) = \kappa_i \int_{-r}^0 |\phi(s)|^2 ds$, where $\kappa_i > 0$. According to [67], for each $\rho \in ((n-1)/n, 1)$, one can find a function $\chi \in \mathcal{K}_\infty$ such that, for all $k \in \mathcal{Z}^+$ and $i \in \mathcal{I}$,

$$V_1^i(t_k, E(t_k)) \leq \rho V_1^i(t_k^-, E(t_k^-)) + \chi(v(t_k^-)). \quad (4.3.26)$$

Moreover, one can easily verify

$$V_2^i(t, \phi) \leq \kappa_i \int_{-r}^0 |\phi(s)|^2 ds \leq \kappa_i r \sup_{-r \leq s \leq 0} V_1^{\tilde{i}}(t+s, \phi(s)), \quad (4.3.27)$$

where $t \geq t_0$, $i, \tilde{i} \in \mathcal{I}$, and $\phi \in \mathcal{PC}$. Therefore, condition (ii) of Theorem 4.3.2 is satisfied with the constants ρ and $\kappa_i r L_i^2$ in place of ρ_i and κ_i , respectively. Computing the upper

right-hand derivative of $V_i(t, \phi)$ along the i th mode of (4.3.24) gives

$$\begin{aligned} D_i^+ V_i(t, \phi) &= 2\phi^T(0)(A_i\phi(0) + \hat{f}_i(\hat{x}(t-r)) - f_i(x(t-r)) - B_i w(t)) \\ &\quad + \kappa_i(|\phi(0)|^2 - |\phi(-r)|^2) \\ &\leq \left(\lambda_{\max}(A_i^T + A_i) + \frac{L_i^2}{\kappa_i} + \kappa_i + \varepsilon \right) V_1^i(t, \phi(0)) + \chi_\varepsilon(|w(t)|), \end{aligned} \quad (4.3.28)$$

where $\varepsilon > 0$ is an arbitrary positive constant and χ_ε is a function in \mathcal{K}_∞ which depends on ε . We claim that, if

$$\ln\left(\frac{n-1}{n} + \kappa_i r\right) < -\left(\lambda_{\max}(A_i^T + A_i) + \frac{L_i^2}{\kappa_i} + \kappa_i\right)\delta_i < 0, \quad (4.3.29)$$

holds for some $\delta_i > 0$ ($i \in \mathcal{I}$), then the error system (4.3.24) is uniformly ISS over $\bigcap_{i \in \mathcal{I}} \mathcal{S}_{\text{sup}}^i(\delta_i)$. In particular, for $\delta = \min_{i \in \mathcal{I}} \delta_i$, system (4.3.15) is uniformly ISS over $\mathcal{S}_{\text{sup}}(\delta)$. Actually, if (4.3.29) holds, one can choose

$$\rho \in ((n-1)/n, 1), \quad \mu_i > \lambda_{\max}(A_i^T + A_i) + L_i^2/\kappa_i + \kappa_i > 0,$$

and $\lambda > 0$ sufficiently small such that

$$\ln(\rho + \kappa_i r e^{\lambda r}) < -(\mu_i + \lambda)\delta_i,$$

i.e., condition (iv) of Theorem 4.3.2 is satisfied. In view of (4.3.28), we can choose $\varepsilon > 0$ sufficiently small such that $D_i^+ V_i(t, \phi) \leq \mu_i V_i(t, \phi)$, i.e., condition (iii) of Theorem 4.3.2 is satisfied. Our claim follows from the conclusion of Theorem 4.3.2. As a numerical example, we take $B_i = [1 \ 0.1 \ 0]$, $f_i(x) = \hat{f}_i(x) = [\alpha_i(a-b) \ 0 \ 0]^T \text{sat}(x_1)$, and

$$A_i = \begin{bmatrix} -\alpha_i(1-b) & \alpha_i & 0 \\ 1 & -1 & 1 \\ 0 & -\beta_i & 0 \end{bmatrix},$$

where $i \in \mathcal{I} = \{1, 2\}$, and $\alpha_1 = 9$, $\beta_1 = 100/7$, $\alpha_2 = 10$, $\beta_2 = 16$, $a = 8/7$, $b = 5/7$. Therefore, the state system can be regarded as a hybrid system switching between two delayed Chua's circuits with slightly different parameters, both of which exhibit chaotic behaviors under the given parameters. It is easy to verify that (4.3.25) is satisfied with $L_1 = 27/7$ and $L_2 = 30/7$. Moreover, $\lambda_{\max}(A_1^T + A_1) = 14.8685$ and $\lambda_{\max}(A_2^T + A_2) = 16.7839$. Now (4.3.29) specifies a condition on the dwell-time upper bound δ_i for the i th mode with $\kappa_i > 0$ as a tuning parameter. With $r = 0.02$ and $n = 3$ and choosing $\kappa_1 = 2.2$ and

$\kappa_2 = 2.4$, (4.3.29) boils down to $\delta_1 < 0.0143$ and $\delta_2 < 0.0125$. Therefore, with $\delta_1 = 0.014$ and $\delta = 0.012$, Theorem 4.3.2 guarantees that the error system (4.3.24) is uniformly ISS over $\bigcap_{i=1,2} \mathcal{S}_{\text{sup}}^i(\delta_i)$. In particular, for $\delta = 0.012$, system (4.3.15) is uniformly ISS over $\mathcal{S}_{\text{sup}}(\delta)$. Simulation results for both the state system (4.3.23) and the error system (4.3.24), under the above parameters, are shown in Figure 4.2. \square

Remark 4.3.10 As discussed in Remark 4.3.7 after Theorem 4.3.2, the parameters κ_i here play important roles in allowing our results to be applied to systems with arbitrarily large delays. Especially, in this example, the impulse amplitude, characterized by the factor ρ , is not arbitrarily chosen, since we have $\rho \in ((n-1)/n, 1)$. The result in [36] (if adapted to hybrid systems with switching modes and applied to deal with this example) would have a restriction on the delay size as (according to their analysis, but using our notation)

$$r < -\frac{\ln(\rho)}{\lambda_{\max}(A_i^T + A_i) + 2L_i} < \frac{\ln(\frac{n}{n-1})}{\lambda_{\max}(A_i^T + A_i) + 2L_i},$$

which, in our numerical example, gives $r < 0.0160$. Therefore, the result in [36] cannot be applied to deal with $r = 0.02$ in the above example. Using our results, the parameters κ_i can be chosen sufficiently small so that, even the delay size r is arbitrarily large, one can still verify inequality (4.3.29) for $\delta_i > 0$ sufficiently small, i.e., the transmission sequence that gives the feedback impulse control is sufficiently frequent. Therefore, we remark that one of the contributions of our results is making the impulse control strategy applicable to systems with arbitrarily large delays. \square

Finally, we present an example of applying impulse control to achieve ISS for a chaotic system generated by delay differential equations.

Example 4.3.4 Consider the following nonlinear scalar delay differential equation with input disturbance

$$x'(t) = ax(t-r) + b \sin(cx(t-r)) + w(t), \quad t \geq 0, \quad (4.3.30)$$

where $a, b, c, r > 0$ are real numbers and $w(t)$ is the input disturbance. It is reported in [113] that the unforced scalar equation (4.3.30) can exhibit chaotic behavior for certain values of a, b, c , and r . One set of such values are $a = -0.16$, $b = 0.4$, $c = 1.8$, and $r = 4.8$. The behavior of $x(t)$ in (4.3.30) with this set of parameters is plotted in Figure 4.4. We consider impulsive ISS stabilization of (4.3.30). Introduce impulses by letting

$$\Delta x(t) = \theta x(t^-) + w(t^-), \quad t = t_k, \quad (4.3.31)$$

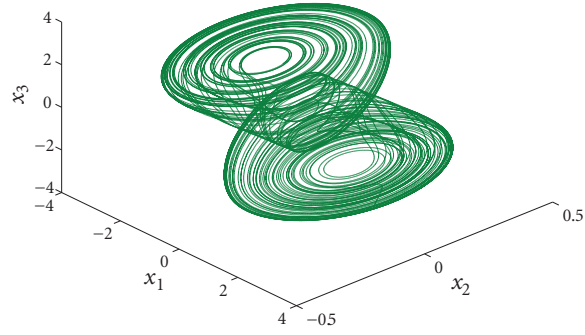

(a) System state: a switching delayed Chua's circuit

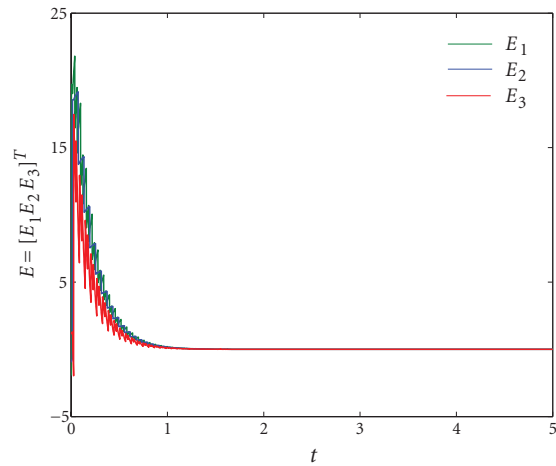

(b) Error system response with exponentially decaying input

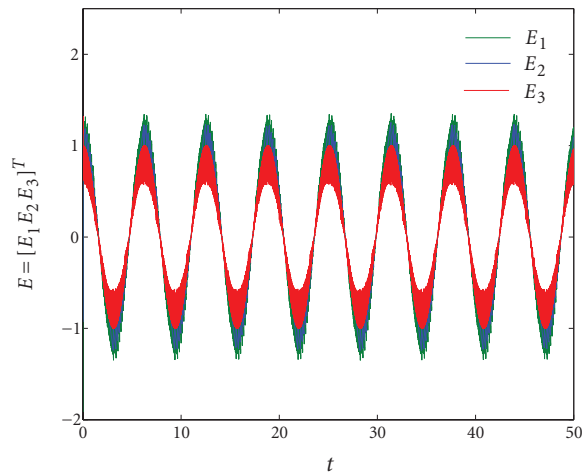

(c) Error system response with periodic input

Figure 4.2 Simulation results for Example 4.3.3.

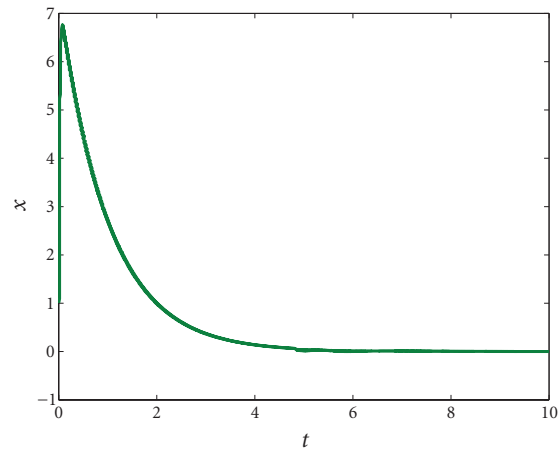

(a) Impulsive input-to-state stabilization with exponentially decaying input

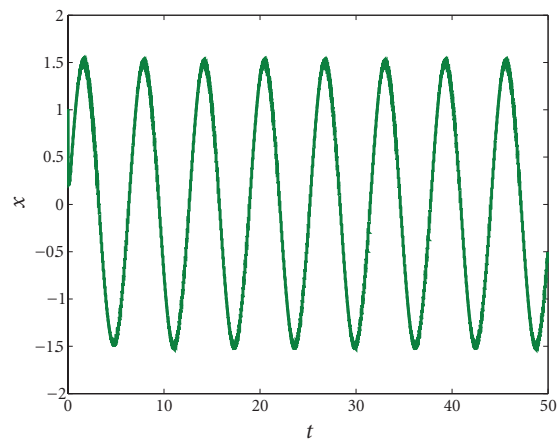

(b) Impulsive input-to-state stabilization with periodic input

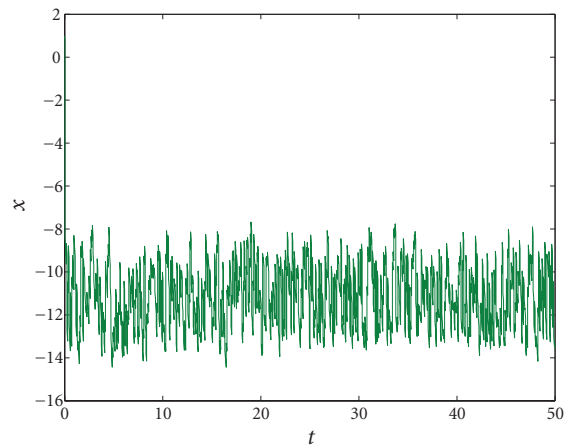

(c) Impulsive input-to-state stabilization with $[-5 \ 5]$ uniformly distributed input

Figure 4.3 Simulation results for Example 4.3.4.

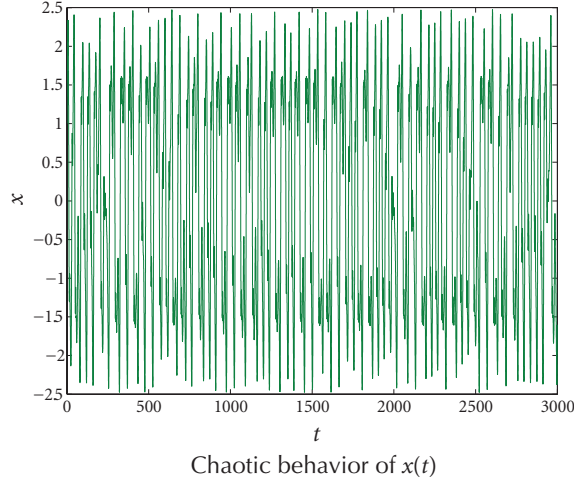

Figure 4.4 Chaotic behavior of $x(t)$ in equation (4.3.30), with $a = -0.16$, $b = 0.4$, $c = 1.8$, $r = 4.8$, and $w(t) \equiv 0$.

where $\theta \in (-2, 0)$. Choose $V(t, \phi) = V_1(t, \phi(0)) + V_2(t, \phi)$, with

$$V_1(t, x) = x^2, \quad V_2(t, \phi) = \kappa \int_{-r}^0 \phi^2(s) ds \leq \kappa r \|\phi\|^2,$$

where $\kappa > 0$. It can be computed that, for any $\mu > \frac{1}{\kappa}(|a| + |bc|)^2 + \kappa$, there exists a function $\chi_1 \in \mathcal{K}_\infty$ such that

$$D^+V(t, \phi) \leq \mu V(t, \phi) + \chi(|w(s)|), \quad t \geq t_0. \quad (4.3.32)$$

Moreover, by (4.3.31) and letting $I(t, x, y) = \theta x + y$, we can verify that, for any $\rho \in ((1 + \theta)^2, 1)$, there exists a function $\chi_2 \in \mathcal{K}_\infty$ such that

$$V_1(t, x + I(t, x, y)) \leq \rho V_1(t, x) + \chi_2(|y|), \quad (4.3.33)$$

for all $t \geq t_0$, $x \in \mathcal{R}$, and $y \in \mathcal{R}$. Therefore, with $\chi = \max(\chi_1, \chi_2)$, conditions (ii) and (iii) of Theorem 4.3.2 are satisfied. If, for some $\delta > 0$,

$$\ln((1 + \theta)^2 + \kappa r) < -\left[\frac{1}{\kappa}(|a| + |bc|)^2 + \kappa\right]\delta, \quad (4.3.34)$$

we can choose $\lambda > 0$, μ , and ρ with $\ln(\rho + \kappa r e^{\lambda r}) < -\mu\delta$ such that both (4.3.32) and (4.3.33) hold, i.e., conditions (ii), (iii), and (iv) of Theorem 4.3.2 are satisfied. Therefore, system (4.3.30) subjected to impulses defined by (4.3.31) are uniformly ISS and iISS over $\mathcal{S}_{\text{sup}}(\delta)$. With $a = -0.16$, $b = 0.4$, $c = 1.8$, $r = 4.8$, $\kappa = 0.1$, $\theta = -0.7$, and $\delta = 0.07$, the relation (4.3.34) is verified and simulation results for (4.3.30) are shown in Figure 4.3. \square

4.4 Summary

We have formulated in this chapter two types of hybrid systems with time-delay. Namely, switched delay systems and general hybrid time-delay systems with all characteristics of switching, impulse, and external inputs or disturbances. The results in Chapter 3 have been partially extended to cover hybrid time-delay systems.

In Section 4.2, the classical LaSalle's principle is extended to switched delay systems with weak dwell-time switchings. This work generalizes the earlier work of [63] on functional differential equations to the hybrid switching setting, by using the notions of weak τ -invariance, where $\tau > 0$ is a weak dwell-time for the class of switching signals considered in this chapter. In proving the weak invariance principle, the notions of persistent mode and persistent limit play important roles. Stability and instability criteria are established, using MLFs, for switched delay systems, as important applications of the invariance principle obtained. Moreover, the idea of [60] is also incorporated here. Based on results obtained using MLFs, an invariance principle and several stability and instability criteria by MLRFs are obtained, which reveals a connection between the MLRF approach and the MLF approach.

The results developed in Section 4.2 can be applied to stability analysis of various practical models involving both switching and time-delays. Applications of these results can provide interesting topics for future research. One particularly interesting example would be using the generalized invariance principles developed in this chapter for switched delay systems to study the stability of both the disease-free solutions and the endemic solutions of delayed infectious disease models with switching parameters.

In Section 4.3, we have applied the method of multiple Lyapunov functionals to investigate input-to-state stability properties of impulsive switching hybrid time-delay systems. Sufficient conditions for input-to-state stability and integral input-to-state stability have been established. The formulation of hybrid systems are quite general in that it allows both the continuous dynamics and the discrete dynamics to be chosen from a certain family, according to a general impulsive and switching signal. The idea of impulsive stabilization for time-delay systems using the method of Lyapunov functionals is exploited, whereas, even for the classical notion of stability (Lyapunov stability), there are very few results concerning the impulsive stabilization of time-delay systems using the Lyapunov functional method. It is also shown that the results can be applied to systems with arbitrarily large delays.

P A R T II

Stochastic Hybrid Systems

C H A **5** P T E R

Stochastic Hybrid Systems with Time-Delay

We have introduced in Chapter 1 that, even though deterministic hybrid models can capture a wide range of behaviors encountered in practice, stochastic features are also very important, because of the uncertainty inherent in most applications and environmental noise ubiquitous in the real world. There has been increasing interest in stochastic hybrid systems due to their many applications and the theory of stochastic differential equations and stochastic processes provides necessary tools to formulate and study stochastic hybrid systems.

The aim of this chapter (which also comprises Part II of this thesis) is to formulate a general mathematical framework for studying practical systems that may exhibit all the hybrid characteristics of impulse effects, switching, stochastic dynamics, and time-delays, establish the fundamental theory regarding existence and uniqueness of solutions, and perform stability analysis and propose stabilization strategies for such systems.

The chapter is organized as follows. In Section 5.1, we present a general formulation for impulsive switched stochastic hybrid time-delay systems and prove existence and uniqueness of solutions. In Section 5.3, we study impulsive stochastic functional equations and show how impulses can destabilize and stabilize a stochastic systems with time-delay. In Section 5.4, we focus on switched stochastic delay systems and extend the ideas of switching stabilization to the stochastic delay setting. In Section 5.5, using ideas from Section 2.4 on switched systems with both stable and unstable modes, and ideas from Section 5.3 on im-

pulsive stabilizing and destabilizing, we establish some general Razumikhin-type theorems on the stability of stochastic hybrid time-delay systems.

We shall start by the general mathematical formulation and fundamental theory.

5.1 Fundamental Theory

5.1.1 Mathematical Formulation

Let $\mathcal{PC}([a, b]; \mathcal{R}^n)$ denote the class of piecewise continuous functions from $[a, b]$ to \mathcal{R}^n as defined in Section 4.1. Given some $r > 0$, we use \mathcal{PC} for $\mathcal{PC}([-r, 0]; \mathcal{R}^n)$ in this chapter. As usual, a norm on \mathcal{PC} is defined as $\|\phi\| = \sup_{-r \leq s \leq 0} |\phi(s)|$ for $\phi \in \mathcal{PC}$. It is easy to see that, although equipped with the norm $\|\cdot\|$, the space \mathcal{PC} is not a Banach space due to the fact that different functions may have different discontinuities. Let Θ be a finite subset of $(-r, 0]$, and, by $\mathcal{PC}[\Theta]$, we denote a subspace of \mathcal{PC} , which contains functions that are continuous on $[-r, 0] \setminus \Theta$ and may have jump discontinuities at the set Θ . Clearly, $\mathcal{PC}[\Theta]$ is a Banach space with respect to the norm $\|\cdot\|$. Suppose that x is a piecewise continuous function in $\mathcal{PC}([-r, \infty); \mathcal{R}^n)$. For any $t \geq 0$, let x_t be an element of \mathcal{PC} defined by $x_t(\theta) := x(t + \theta)$, $-r \leq \theta \leq 0$.

Let (Ω, \mathcal{F}, P) be a given complete probability space with $\{\mathcal{F}_t\}_{t \geq 0}$ as a filtration satisfying the usual conditions, and $W(t)$ be an m -dimensional standard Wiener process defined on (Ω, \mathcal{F}, P) and adapted to $\{\mathcal{F}_t\}_{t \geq 0}$.

Definition 5.1.1 By a **\mathcal{PC} -valued random variable**, we mean a mapping $\xi : \Omega \rightarrow \mathcal{PC}[\Theta]$ that is $\mathcal{F}/\mathcal{B}[\Theta]$ -measurable (or simply \mathcal{F} -measurable), where Θ is a finite subset of $(-r, 0]$ and $\mathcal{B}[\Theta]$ is the Borel σ -algebra of $\mathcal{PC}[\Theta]$. A **\mathcal{PC} -valued stochastic process** is a collection of \mathcal{PC} -valued random variables indexed by a set T , i.e., a collection $\{\phi_t\}_{t \in T}$, where each ϕ_t is a \mathcal{PC} -valued random variable. \square

For $p > 0$ and $t \geq 0$, let $\mathcal{L}_{\mathcal{F}_t}^p$ denote the family of all \mathcal{F}_t -measurable \mathcal{PC} -valued random variables ϕ such that $E\{\|\phi\|^p\} < \infty$, where $E\{\cdot\}$ denotes the mathematical expectation. Let $\mathcal{L}_{\mathcal{F}_{t_0}}^b$ be the family of \mathcal{PC} -valued random variables that are bounded and \mathcal{F}_t -measurable. Let $\mathcal{L}^1([a, b]; \mathcal{R}^n)$ denote the space of all \mathcal{R}^n -valued \mathcal{F}_t -adapted processes $\{f(t)\}_{a \leq t \leq b}$ such that $\int_a^b |f(t)| dt < \infty$ almost surely (a.s.) and $\mathcal{L}^2([t_0, T]; \mathcal{R}^{n \times m})$ the space of all $\mathcal{R}^{n \times m}$ -valued \mathcal{F}_t -adapted processes $\{g(t)\}_{a \leq t \leq b}$ such that $\int_a^b |g(t)|^2 dt < \infty$ a.s.

Consider the impulsive switched stochastic delay system:

$$\begin{cases} dx(t) = f_{i_k}(t, x_t)dt + g_{i_k}(t, x_t)dW(t), & t \in [t_k, t_{k+1}), & (5.1.1a) \\ \Delta x(t) = I_{j_k}(t, x_{t-}), & t = t_k, & (5.1.1b) \\ x_{t_0} = \xi, & & (5.1.1c) \end{cases}$$

where $\{(t_k, i_k, j_k)\}$ is an impulsive switching signal associated with the index sets \mathcal{I} and \mathcal{J} . The initial data ξ is a \mathcal{PC} -valued random variable. The \mathcal{PC} -valued stochastic process x_{t-} is defined by $x_{t-}(s) = x(t+s)$, for $s \in [-r, 0)$, and $x_{t-}(0) = x(t^-)$, where $x(t^-) = \lim_{s \rightarrow t^-} x(s)$. For each $i \in \mathcal{I}$ and $j \in \mathcal{J}$,

$$f_i : \mathcal{R}^+ \times \mathcal{PC} \rightarrow \mathcal{R}^n, \quad g_i : \mathcal{R}^+ \times \mathcal{PC} \rightarrow \mathcal{R}^{n \times m}, \quad I_j : \mathcal{R}^+ \times \mathcal{PC} \rightarrow \mathcal{R}^n.$$

Given an impulsive switching signal $\{(t_k, i_k, j_k)\}$, we can define

$$\sigma(t) = i_k, \quad t \in [t_k, t_{k+1}), \quad k \in \mathcal{Z}^+, \quad (5.1.2)$$

where σ recovers a switching signal for system (5.1.1a). While the formulation in system (5.1.1) emphasizes the impulsive switching signal $\{(t_k, i_k, j_k)\}$ as a whole, defining σ by (5.1.2) enables us to rewrite system (5.1.1a) as a switched stochastic system

$$\begin{cases} dx(t) = f_\sigma(t, x_t)dt + g_\sigma(t, x_t)dW(t), & t \geq t_0, \\ x_{t_0} = \xi, \end{cases} \quad (5.1.3)$$

which will serve as a general formulation of the switched stochastic system to be investigated in Section 5.4, and also simplify some notation in the following definition for solutions to system (5.1.1).

Definition 5.1.2 For $0 \leq t_0 < T < \infty$ and a given impulsive switching signal $\{(t_k, i_k, j_k)\}$, an \mathcal{R}^n -valued process $\{x(t)\}_{t_0-r \leq t \leq T}$ is called a **solution** to system (5.1.1) on $[t_0, T]$, if it satisfies the following:

- (i) $x(t)$ is continuous at $t \in [t_0, T] \setminus \{t_k : k \in \mathcal{Z}^+\}$ and right-continuous at $t \in [t_0, T] \cap \{t_k : k \in \mathcal{Z}^+\}$;
- (ii) $\{x_t\}_{t_0 \leq t \leq T}$ as a \mathcal{PC} -valued process is \mathcal{F}_t -adapted;
- (iii) $\{f_{\sigma(t)}(t, x_t)\}_{t_0 \leq t \leq T} \in \mathcal{L}^1([t_0, T]; \mathcal{R}^n)$ and $\{g_{\sigma(t)}(t, x_t)\}_{t_0 \leq t \leq T} \in \mathcal{L}^2([t_0, T]; \mathcal{R}^{n \times m})$, where σ is defined by (5.1.2);

(iv) $x_{t_0} = \xi$ and, for any $t \in [t_0, T]$, it holds with probability 1 that

$$x(t) = \xi(t_0) + \int_{t_0}^t f_{\sigma(s)}(s, x_s) ds + \int_{t_0}^t g_{\sigma(s)}(s, x_s) dW(s) + \sum_{t_0 \leq t_k \leq T} I_{jk}(t_k, x_{t_k^-}).$$

A solution $\{x(t)\}_{t_0 \leq t \leq T}$ to (5.1.1) on $[t_0, T]$ is said to be **unique**, if any other solution, say $\{y(t)\}_{t_0 \leq t \leq T}$, to (5.1.1) on $[t_0, T]$ is indistinguishable to $\{x(t)\}_{t_0 \leq t \leq T}$, i.e.,

$$P \{x(t) = y(t), \forall t \in [t_0, T]\} = 1.$$

An \mathcal{R}^n -valued process $\{x(t)\}_{t_0 \leq t < \infty}$ is called a **solution** to system (5.1.1) on $[t_0, \infty)$, if, for any $T > 0$, the restricted process $\{x(t)\}_{t_0 \leq t \leq T}$ is a solution to system (5.1.1) on $[t_0, T]$. \square

5.1.2 Existence and Uniqueness

In this section, existence and uniqueness of solutions of system (5.1.1) are investigated. Before stating the main result, we introduce an assumption on the functionals f_i and g_i in system (5.1.1), which is a typical assumption proposed for considering existence and uniqueness of impulsive delay differential equations ([9], [111]).

Definition 5.1.3 A functional $f : \mathcal{R}^+ \times \mathcal{PC} \rightarrow \mathcal{R}^n$ (or $g : \mathcal{R}^+ \times \mathcal{PC} \rightarrow \mathcal{R}^{n \times m}$) is said to be **composite-PC** on $[t_0, T]$, where $0 \leq t_0 < T < \infty$, if, for each function x that is piecewise continuous on $[t_0 - r, T]$, the composite function $f(t, x_t)$ (or $g(t, x_t)$) is piecewise continuous on $[t_0, T]$. \square

Lemma 5.1.1 Let $\{x(t)\}_{t_0-r \leq t \leq T}$ be a process satisfying

- (i) $x(t)$ is piecewise continuous on $[t_0, T]$ and $\{x(t)\}_{t_0 \leq t \leq T}$ is \mathcal{F}_t -adapted; and
- (ii) x_{t_0} is a \mathcal{PC} -valued \mathcal{F}_{t_0} -measurable random value.

Then $\{x_t\}_{t_0 \leq t \leq T}$ as a \mathcal{PC} -valued process is \mathcal{F}_t -adapted.

Proof. Let $t \in [t_0, T]$ be arbitrarily chosen and fixed. We shall show that x_t as a \mathcal{PC} -valued random value is \mathcal{F}_t -measurable. By Definition 5.1.1, we have to show that there exists a finite set Θ in $(-r, 0]$ such that the mapping $x_t : \Omega \rightarrow \mathcal{PC}[\Theta]$ is $\mathcal{F}_t/\mathcal{B}[\Theta]$ -measurable. Since ξ is a \mathcal{PC} -valued \mathcal{F}_{t_0} -measurable random value, there exists a finite set Θ' in $(-r, 0]$ such that ξ is an $\mathcal{F}_{t_0}/\mathcal{B}[\Theta']$ -measurable mapping from Ω to $\mathcal{PC}[\Theta']$. Moreover, let Θ'' be the set of points of discontinuity of $x(t)$ on $[t_0, T]$. Define

$$\Theta = \{s \in [-r, 0] : t + s \in \Theta'' \quad \text{or} \quad t + s - t_0 \in \Theta'\}.$$

We claim that x_t defines a mapping from Ω to $\mathcal{PC}[\Theta]$ and it is $\mathcal{F}_t/\mathcal{B}[\Theta]$ -measurable. The first part of the claim is obvious, since $x_t(s)$ can be discontinuous at s only if $t + s$ is a point of discontinuity of $x(t)$ or $t + s - t_0$ is a discontinuity point of ξ . To show that x_t is $\mathcal{F}_t/\mathcal{B}[\Theta]$ -measurable, notice that $\mathcal{PC}[\Theta]$ is a separable Banach space. Hence any open set in $\mathcal{PC}[\Theta]$ can be written as a countable union of closed balls of the form

$$B(\phi, \varepsilon) = \{\psi \in \mathcal{PC}[\Theta] : \|\phi - \psi\| \leq \varepsilon\},$$

where $\varepsilon > 0$ and $\phi \in \mathcal{PC}[\Theta]$. It suffices to show that the inverse image of each $B(\phi, \varepsilon)$ under the mapping x_t , denoted by $x_t^{-1}(B(\phi, \varepsilon))$, is contained in \mathcal{F}_t . By right-continuity of the elements in $\mathcal{PC}[\Theta]$, we can rewrite $B(\phi, \varepsilon)$ as

$$B(\phi, \varepsilon) = \bigcap_{m=1}^{\infty} \{\psi \in \mathcal{PC}[\Theta] : |\psi(s_m) - \phi(s_m)| \leq \varepsilon\},$$

where $\{s_m\}_{m=1}^{\infty}$ is a sequential representation of all the rational numbers in $[-r, 0]$. Therefore,

$$x_t^{-1}(B(\phi, \varepsilon)) = \bigcap_{m=1}^{\infty} \{\omega \in \Omega : |x(t + s_m) - \phi(s_m)| \leq \varepsilon\} := \bigcap_{m=1}^{\infty} A_m$$

Since $\{x(t)\}_{t_0 \leq t \leq T}$ is \mathcal{F}_t -adapted, we have $A_m \in \mathcal{F}_{t+s_m} \subset \mathcal{F}_t$, if $t + s_m \geq t_0$. To show that $A_m \in \mathcal{F}_t$ still holds for $t + s_m < t_0$, define, for each $s \in [-r, 0]$, a mapping $e_s : \mathcal{PC}[\Theta'] \rightarrow \mathcal{R}^n$ by $e_s(\phi) = \phi(s)$, i.e., evaluating ϕ at s . It is easy to see that, for each $s \in [-r, 0]$, the mapping e_s is continuous. Since $\xi(s)(\cdot) = e_s \circ \xi$, it follows that $\xi(s)(\cdot) : \Omega \rightarrow \mathcal{R}^n$ is \mathcal{F}_{t_0} -measurable for each $s \in [-r, 0]$. Hence, if $t + s_m < t_0$, we still have $A_m \in \mathcal{F}_{t_0} \subset \mathcal{F}_t$, since $x(t + s_m) = \xi(t + s_m - t_0)$ and $\xi(s)(\cdot) : \Omega \rightarrow \mathcal{R}^n$ is \mathcal{F}_{t_0} -measurable for each $s \in [-r, 0]$. The proof is complete. \square

Theorem 5.1.1 *If*

- (i) *for each $i \in \mathcal{I}$ and $j \in \mathcal{J}$, $f_i(t, \phi)$, $g_i(t, \phi)$, and $I_j(t, \phi)$ are Borel measurable on $[t_0, T] \times \mathcal{PC}[\Theta]$, for each finite subset Θ of $(-r, 0]$, and $f_i(t, \phi)$ and $g_i(t, \phi)$ are composite-PC on $[t_0, T]$;*
- (ii) *there exists a positive constant K such that for $(t, \phi, \psi) \in [t_0, T] \times \mathcal{PC} \times \mathcal{PC}$ and $i \in \mathcal{I}$,*

$$|f_i(t, \phi) - f_i(t, \psi)| + |g_i(t, \phi) - g_i(t, \psi)| \leq K \|\phi - \psi\|, \quad (5.1.4)$$

and

$$|f_i(t, \phi)|^2 + |g_i(t, \phi)|^2 \leq K^2(1 + \|\phi\|^2); \quad (5.1.5)$$

(iii) ξ is a PC-valued \mathcal{F}_{t_0} -measurable random value,

then there exists a unique solution to system (5.1.1) on $[t_0, T]$.

Proof. Throughout this proof, let $\{(t_k, i_k, j_k)\}$ be a given impulsive switching signal. The proof is completed in the following procedure (a)-(d).

(a) Uniqueness. Suppose $t_0 < t_1 < t_2 < \dots < t_m = T$, where t_k , for $k = 1, 2, \dots, m-1$, are the impulse and switching times between t_0 and T . We let $t_m = T$ to simplify the notation; if there are no impulses between t_0 and T , we can still take $t_1 = T$ and the following argument holds with the same notation. Let $x(t)$ and $y(t)$ be two solutions to (5.1.1) on $[t_0, T]$. We first show that

$$\mathbb{E} \left\{ \|x_t - y_t\|^2 \right\} = 0, \quad \forall t \in [t_0, t_1].$$

Define, for $N > 0$ and $t \in [t_0, t_1]$, that

$$\chi_N(t) = \begin{cases} 1, & \text{if } \|x_s\| \vee \|y_s\| \leq N, \quad \forall s \in [t_0, t], \\ 0, & \text{otherwise.} \end{cases}$$

It is clear that $\chi_N(t) = \chi_N(t)\chi_N(s)$ for $s \leq t$. Therefore, for $t \in [t_0, t_1]$,

$$\begin{aligned} \chi_N(t)[x(t) - y(t)] = \chi_N(t) & \left\{ \int_{t_0}^t \chi_N(s)[f_{i_0}(s, x_s) - f_{i_0}(s, y_s)]ds \right. \\ & \left. + \int_{t_0}^t \chi_N(s)[g_{i_0}(s, x_s) - g_{i_0}(s, y_s)]dW(s) \right\}, \end{aligned} \quad (5.1.6)$$

where $i_0 = \sigma(t_0)$. By the Lipschitz condition (5.1.4), for $s \in [t_0, t_1]$,

$$\chi_N(s) \left(|f_{i_0}(s, x_s) - f_{i_0}(s, y_s)| + |g_{i_0}(s, x_s) - g_{i_0}(s, y_s)| \right) \leq K \chi_N(s) \|x_s - y_s\| \leq 2KN. \quad (5.1.7)$$

Using (5.1.7), Schwarz's inequality, and Doob's martingale inequality on (5.1.6), we can show that, for $t \in [t_0, t_1]$,

$$\begin{aligned} \mathbb{E} \left\{ \chi_N(t) \|x_t - y_t\|^2 \right\} &= \mathbb{E} \left\{ \chi_N(t) \sup_{t-r \leq s \leq t} |x(s) - y(s)|^2 \right\} \\ &\leq \mathbb{E} \left\{ \left\{ \sup_{t-r \leq s \leq t} |\chi_N(s)[x(s) - y(s)] \right\}^2 \right\} \\ &\leq 2(t_1 - t_0 + 4)K^2 \int_{t_0}^t \mathbb{E} \left\{ \chi_N(s) \|x_s - y_s\|^2 \right\} ds, \end{aligned}$$

which, by Gronwall's inequality, implies that

$$\mathbb{E} \left\{ \chi_N(t) \|x_t - y_t\|^2 \right\} = 0, \quad t \in [t_0, t_1].$$

Letting $N \rightarrow \infty$, the monotone convergence theorem implies that

$$\mathbb{E} \left\{ \|x_t - y_t\|^2 \right\} = 0, \quad t \in [t_0, t_1].$$

Therefore, $x(t) = y(t)$ a.s. for $t \in [t_0, t_1]$. Since $x(t)$ and $y(t)$ both have continuous samples on $[t_0, t_1]$, we have

$$P \left\{ x(t) = y(t), \forall t \in [t_0, t_1] \right\} = 1.$$

At $t = t_1$, we consider two cases. If t_1 is not an impulse and switching time, then $x(t_1) = y(t_1)$ a.s. by continuity of solutions at $t = t_1$. If t_1 is an impulse and switching time, then

$$x(t_1) = x(t_1^-) + I_{j_1}(t_1, x_{t_1^-}) = y(t_1^-) + I_{j_1}(t_1, y_{t_1^-}) = y(t_1), \quad \text{a.s.}$$

Therefore,

$$P \left\{ x(t) = y(t), \forall t \in [t_0, t_1] \right\} = 1.$$

Note that now we have $x_{t_1} = y_{t_1}$ a.s. and the previous argument can be repeated on $[t_1, t_2]$ and, by induction, on $[t_k, t_{k+1})$ for $k = 1, 2, \dots, m-1$. Hence

$$P \left\{ x(t) = y(t), \forall t \in [t_0, T] \right\} = 1.$$

(b) Existence on $[t_0, t_1]$ (if $\mathbb{E} \{ \|\xi\|^2 \} < \infty$). We first assume that $\mathbb{E} \{ \|\xi\|^2 \} < \infty$. The general initial data will be treated in part (c). Define, for $n \geq 1$ and $t \in [t_0, t_1]$,

$$x^{(n)}(t) = \xi(t_0) + \int_{t_0}^t f_{i_0}(s, x_s^{(n-1)}) ds + \int_{t_0}^t g_{i_0}(s, x_s^{(n-1)}) dW(s), \quad (5.1.8)$$

with $x^{(0)}(t) \equiv \xi(t_0)$ on $[t_0, t_1]$, and $x_{t_0}^{(n)} = \xi$. It is easy to see that the following conditions (to be referred to as conditions **(I)**-**(III)**) hold for $n = 0$:

- I. $\{x_t^{(n)}\}_{t_0 \leq t < t_1}$ as a \mathcal{PC} -valued process is \mathcal{F}_t -adapted;
- II. $\{x^{(n)}(t)\}_{t_0-r \leq t < t_1}$ is piecewise continuous on $[t_0 - r, t_0]$ and continuous on $[t_0, t_1]$; and
- III. $\mathbb{E} \left\{ \int_{t_0}^{t_1} \|x_s^{(n)}\|^2 ds \right\} < \infty$.

Assume, by induction, that $\{x^{(n)}(t)\}_{t_0-r \leq t < t_1}$ satisfies conditions (I)–(III) for some $n \geq 0$. Then by the linear growth condition (5.1.5),

$$\mathbb{E} \left\{ \int_{t_0}^{t_1} |g_{i_0}(s, x_s^{(n)})|^2 ds \right\} \leq K^2(t_1 - t_0) + K^2 \mathbb{E} \left\{ \int_{t_0}^{t_1} \|x_s^{(n)}\|^2 ds \right\} < \infty,$$

and

$$\int_{t_0}^{t_1} |f_{i_0}(s, x_s^{(n)})| ds \leq K\sqrt{b-a} \left(\int_{t_0}^{t_1} (1 + \|x_s^{(n)}\|^2) ds \right)^{\frac{1}{2}} < \infty, \quad \text{a.s.}$$

Therefore, the integrals in (5.1.8) are well-defined. It follows that $\{x^{(n+1)}(t)\}_{t_0 \leq t < t_1}$ is \mathcal{F}_t -adapted and continuous on $[t_0, t_1]$. By Lemma 5.1.1, $\{x_t^{(n+1)}\}_{t_0 \leq t < t_1}$ as a \mathcal{PC} -valued process is \mathcal{F}_t -adapted. Moreover, by virtue of the inequality $|a + b + c|^2 \leq 3(a^2 + b^2 + c^2)$, the linear growth condition (5.1.5), and (5.1.8), we have, for $t \in [t_0, t_1]$,

$$\begin{aligned} \mathbb{E} \left\{ \|x_t^{(n+1)}\|^2 \right\} &= \mathbb{E} \left\{ \sup_{t-r \leq s \leq t} |x^{(n+1)}(t)|^2 \right\} \\ &\leq 3 \mathbb{E} \left\{ \|\xi\|^2 \right\} + 3 \mathbb{E} \left\{ \sup_{t_0 \vee (t-r) \leq s \leq t} \left(\int_{t_0}^s f_{i_0}(s, x_s^{(n)}) ds \right)^2 \right\} \\ &\quad + 3 \mathbb{E} \left\{ \sup_{t_0 \vee (t-r) \leq s \leq t} \left(\int_{t_0}^s g_{i_0}(s, x_s^{(n)}) dW(s) \right)^2 \right\} \\ &\leq 3 \mathbb{E} \left\{ \|\xi\|^2 \right\} + 3(t_1 - t_0)K^2 \left[(t_1 - t_0) + \mathbb{E} \left\{ \int_{t_0}^{t_1} \|x_s^{(n)}\|^2 ds \right\} \right] \\ &\quad + 3 \mathbb{E} \left\{ \sup_{t_0 \vee (t-r) \leq s \leq t} \left(\int_{t_0}^s g_{i_0}(s, x_s^{(n)}) dW(s) \right)^2 \right\}, \quad (5.1.9) \end{aligned}$$

where, by Doob's martingale inequality and the linear growth condition (5.1.5),

$$\begin{aligned} \mathbb{E} \left\{ \sup_{t_0 \vee (t-r) \leq s \leq t} \left(\int_{t_0}^s g_{i_0}(s, x_s^{(n)}) dW(s) \right)^2 \right\} &\leq 4 \mathbb{E} \left\{ \int_{t_0}^{t_1} |g_{i_0}(s, x_s^{(n)})|^2 ds \right\} \\ &\leq 4K^2(t_1 - t_0) + 4K^2 \mathbb{E} \left\{ \int_{t_0}^{t_1} \|x_s^{(n)}\|^2 ds \right\}. \end{aligned}$$

Hence, (5.1.9) shows that

$$\mathbb{E} \left\{ \int_{t_0}^{t_1} \|x^{(n+1)}(t)\|^2 dt \right\} = \int_{t_0}^{t_1} \mathbb{E} \left\{ \|x^{(n+1)}(t)\|^2 \right\} dt < \infty.$$

Therefore, by induction, we have a sequence of processes $\{x^{(n)}(t)\}_{t_0-r \leq t < t_1}$ satisfying conditions (I)–(III) for all $n \geq 0$. Next, we estimate $\mathbb{E} \left\{ \|x_t^{(n+1)} - x_t^{(n)}\|^2 \right\}$, for $n \geq 0$ and

$t \in [t_0, t_1]$. For $n = 0$ and $t \in [t_0, t_1]$, by the linear growth condition (5.1.5) and (5.1.8), we have

$$\begin{aligned}
\mathbb{E} \left\{ \|x_t^{(1)} - x_t^{(0)}\|^2 \right\} &= \mathbb{E} \left\{ \sup_{t-r \leq s \leq t} |x^{(1)}(t) - x^{(0)}(t)|^2 \right\} \\
&\leq 2 \mathbb{E} \left\{ \sup_{t_0 \vee (t-r) \leq s \leq t} \left(\int_{t_0}^s f_{i_0}(s, x_s^{(0)}) ds \right)^2 \right\} \\
&\quad + 2 \mathbb{E} \left\{ \sup_{t_0 \vee (t-r) \leq s \leq t} \left(\int_{t_0}^s g_{i_0}(s, x_s^{(0)}) dW(s) \right)^2 \right\} \\
&\leq 2(t_1 - t_0)K^2 \left[(t_1 - t_0) + \mathbb{E} \left\{ \int_{t_0}^{t_1} \|x_s^{(n)}\|^2 ds \right\} \right] \\
&\quad + 8K^2(t_1 - t_0) + 8K^2 \mathbb{E} \left\{ \int_{t_0}^{t_1} \|x_s^{(n)}\|^2 ds \right\} \\
&\leq 2(t_1 - t_0)K^2(t_1 - t_0 + 4)(1 + \mathbb{E} \{ \|\xi\|^2 \}) \triangleq L. \tag{5.1.10}
\end{aligned}$$

We claim that

$$\mathbb{E} \left\{ \|x_t^{(n+1)} - x_t^{(n)}\|^2 \right\} \leq \frac{L[C(t - t_0)]^n}{n!}, \quad n \geq 0, \quad t \in [t_0, t_1], \tag{5.1.11}$$

where $C = 2K^2(t_1 - t_0 + 4)$. It is shown in (5.1.10) that the claim holds for $n = 0$. Suppose (5.1.11) is true for some $n \geq 0$. Then

$$\begin{aligned}
\mathbb{E} \left\{ \|x_t^{(n+2)} - x_t^{(n+1)}\|^2 \right\} &= \mathbb{E} \left\{ \sup_{t-r \leq s \leq t} |x^{(1)}(t) - x^{(0)}(t)|^2 \right\} \\
&\leq 2 \mathbb{E} \left\{ \sup_{t_0 \vee (t-r) \leq s \leq t} \left(\int_{t_0}^s [f_{i_0}(s, x_s^{(n+1)}) - f_{i_0}(s, x_s^{(n)})] ds \right)^2 \right\} \\
&\quad + 2 \mathbb{E} \left\{ \sup_{t_0 \vee (t-r) \leq s \leq t} \left(\int_{t_0}^s [g_{i_0}(s, x_s^{(n+1)}) - g_{i_0}(s, x_s^{(n)})] dW(s) \right)^2 \right\} \\
&\leq 2K^2(t_1 - t_0 + 4) \int_{t_0}^t \mathbb{E} \left\{ \|x_s^{(n+1)} - x_s^{(n)}\|^2 ds \right\} \\
&\leq C \int_{t_0}^t \frac{L[C(s - t_0)]^n}{n!} ds = \frac{L[C(t - t_0)]^{n+1}}{(n+1)!}. \tag{5.1.12}
\end{aligned}$$

Therefore, by induction, the claim is true for all $n \geq 0$. From (5.1.12), it follows that, for any fixed $t \in [t_0, t_1]$,

$$P \left\{ \sup_{t-r \leq s \leq t} |x^{(n+1)}(s) - x^{(n)}(s)| > \frac{1}{n^2} \right\} \leq \frac{Ln^4[C(t_1 - t_0)]^n}{n!}.$$

It is easy to check that $\sum_{n=0}^{\infty} \frac{Ln^4[C(t_1-t_0)]^n}{n!} < \infty$. Hence by the Borel-Cantelli lemma, for any fixed $t \in [t_0, t_1]$,

$$P\left\{\sup_{t-r \leq s \leq t} |x^{(n+1)}(s) - x^{(n)}(s)| > \frac{1}{n^2} \text{ i.o.}\right\} = 0,$$

where i.o. stands for infinitely often. The above equation implies that the partial sum $\xi(t_0) + \sum_{i=0}^{n-1} [x^{(i+1)}(s) - x^{(i)}(s)] = x^{(n)}(s)$ converges uniformly on $[t-r, t]$, with probability 1, for any fixed $t \in [t_0, t_1]$. Since the interval $[t_0, t_1]$ is of finite length and $r > 0$, it actually follows that $x^{(n)}(s)$ converges uniformly on $[t_0 - r, t_1]$, with probability 1. Let the limit process be $\{x(t)\}_{t_0-r \leq t \leq t_1}$, i.e.,

$$x(t) = \lim_{n \rightarrow \infty} x^{(n)}(t), \quad \text{uniformly for } t \in [t_0 - r, t_1].$$

It is easy to see that the process $\{x(t)\}_{t_0-r \leq t \leq t_1}$ is piecewise continuous on $[t_0 - r, t_0]$ (with $x_{t_0} = \xi$), continuous on $[t_0, t_1]$, and adapted to \mathcal{F}_t for $t \geq t_0$. It follows from Lemma 5.1.1 that $\{x_t\}_{t_0 \leq t \leq t_1}$ as a \mathcal{PC} -valued process is also \mathcal{F}_t -adapted for $t \geq t_0$. Hence $\{x(t)\}_{t_0-r \leq t \leq t_1}$ satisfies both (i) and (ii) in Definition 5.1.2. Moreover, we can easily verify that

$$\begin{aligned} \mathbb{E}\left\{\int_{t_0}^{t_1} |g_{i_0}(s, x_s)|^2 ds\right\} &\leq K^2(t_1 - t_0) + K^2 \mathbb{E}\left\{\int_{t_0}^{t_1} \|x_s\|^2 ds\right\} < \infty, \\ \int_{t_0}^{t_1} |f_{i_0}(s, x_s)| ds &\leq K\sqrt{b-a} \left(\int_{t_0}^{t_1} (1 + \|x_s\|^2) ds\right)^{\frac{1}{2}} < \infty, \quad \text{a.s.,} \end{aligned}$$

which implies that

$$\{f_{\sigma(t_0)}(t, x_t)\}_{t_0 \leq t \leq t_1} \in \mathcal{L}^1([t_0, t_1]; \mathcal{R}^n), \quad \{g_{\sigma(t_0)}(t, x_t)\}_{t_0 \leq t \leq t_1} \in \mathcal{L}^2([t_0, t_1]; \mathcal{R}^{n \times m}),$$

and hence (iii) in Definition 5.1.2 is satisfied and the right-hand side of the equation

$$x(t) = \xi(t_0) + \int_{t_0}^t f_{\sigma(s)}(s, x_s) ds + \int_{t_0}^t g_{\sigma(s)}(s, x_s) dW(s), \quad t \in [t_0, t_1], \quad (5.1.13)$$

is meaningful. The validity of equation (5.1.13) can be shown by passing the limit as $n \rightarrow \infty$ in (5.1.8) and the facts that

- (i) $x^{(n)}(s)$ converges uniformly to $x(s)$ with probability 1 for $s \in [t_0 - r, t_1]$;
- (ii) $f_{\sigma(s)}(s, x_s^n)$ converges uniformly to $f_{\sigma(s)}(s, x_s)$ with probability 1 for $s \in [t_0, t_1]$; and
- (iii) $g_{\sigma(s)}(s, x_s^n)$ converges uniformly to $g_{\sigma(s)}(s, x_s)$ with probability 1 for $s \in [t_0, t_1]$ and hence, as $n \rightarrow \infty$,

$$\int_{t_0}^t |g_{\sigma(s)}(s, x_s^n) - g_{\sigma(s)}(s, x_s)|^2 ds \xrightarrow{P} 0, \quad t \in [t_0, t_1],$$

which implies

$$\int_{t_0}^t g_{\sigma(s)}(s, x_s^n) dW(s) \xrightarrow{P} \int_{t_0}^t g_{\sigma(s)}(s, x_s) dW(s), \quad t \in [t_0, t_1],$$

as $n \rightarrow \infty$.

In summary, there exists a process $\{x(t)\}_{t_0-r \leq t \leq t_1}$ satisfying (i)-(iii) of Definition, $x_{t_0} = \xi$, and (5.1.13) on $[t_0, t_1]$.

(c) Existence on $[t_0, t_1]$ (general). For general initial data ξ that is a \mathcal{F}_{t_0} -measurable \mathcal{PC} -valued random variable, we define, for $N > 0$,

$$\xi^N = \begin{cases} \xi, & \|\xi\| \leq N, \\ 0, & \text{otherwise.} \end{cases}$$

According to the previous argument, there exists a process $\{x^N(t)\}_{t_0-r \leq t \leq t_1}$ satisfying

$$x^N(t) = \xi^N(t_0) + \int_{t_0}^t f_{\sigma(s)}(s, x_s^N) ds + \int_{t_0}^t g_{\sigma(s)}(s, x_s^N) dW(s), \quad t \in [t_0, t_1], \quad (5.1.14)$$

and $x_{t_0}^N = \xi^N$. Suppose that $M > N$. Define an \mathcal{F}_{t_0} -measurable random variable χ_N as $\chi_N = 1$, for $\|\xi\| \leq N$, and $\chi_N = 0$, for $\|\xi\| > N$. Then $\chi_N[x_{t_0}^M - x_{t_0}^N] = 0$ and we can show that, for $t \in [t_0, t_1]$,

$$\begin{aligned} \mathbb{E} \left\{ \chi_N \|x_t^M - x_t^N\| \right\} &\leq \mathbb{E} \left\{ \chi_N \sup_{t-r \leq s \leq t} |x^M(s) - x^N(s)| \right\} \\ &\leq 2(t_1 - t_0 + 4)K^2 \int_{t_0}^t \mathbb{E} \left\{ \chi_N \|x_s^M - x_s^N\|^2 \right\} ds, \end{aligned}$$

which, by Gronwall's inequality, implies that

$$\mathbb{E} \left\{ \chi_N \|x_t^M - x_t^N\|^2 \right\} = 0, \quad t \in [t_0, t_1],$$

and hence, for $t \in [t_0, t_1]$,

$$P \left\{ \sup_{M>N} \|x_t^M - x_t^N\| > 0 \right\} \leq P \left\{ \bigcup_{M>N} \{ \|x_t^M - x_t^N\| > 0 \} \right\} \leq P \{ \|\xi\| > N \}.$$

Since $P \{ \|\xi\| > N \} \rightarrow 0$ as $N \rightarrow \infty$, it follows from the previous inequality that, for fixed $t \in [t_0, t_1]$, the sequence $\{x_t^N\}_{N=1}^{\infty}$ is a Cauchy sequence with respect to the supremum norm $\|\cdot\|$ with probability 1, i.e., $x^N(s)$ converges uniformly on $[t-r, t]$, with probability 1, for any fixed $t \in [t_0, t_1]$. Since the interval $[t_0, t_1]$ is of finite length and $r > 0$, it actually follows

that $x^N(s)$ converges uniformly on $[t_0 - r, t_1]$, with probability 1. Let the limit process be $\{x(t)\}_{t_0-r \leq t \leq t_1}$, i.e.,

$$x(t) = \lim_{N \rightarrow \infty} x^N(t), \quad \text{uniformly for } t \in [t_0 - r, t_1].$$

Passing the limit as $N \rightarrow \infty$ in (5.1.14) (for details, see the argument in the previous case for passing the limit of $\{x^{(n)}(t)\}$ in (5.1.8) to obtain (5.1.13)) shows that $\{x(t)\}_{t_0-r \leq t \leq t_1}$ satisfies (i)-(iii) of Definition 5.1.2 and (5.1.13) with $x_{t_0} = \xi$.

(d) Existence on $[t_0, T]$. If $t_1 = T$, this part is not necessary and the proof is already complete. If $t_1 < T$, we proceed to show that we can modify the process $\{x(t)\}_{t_0-r \leq t \leq t_1}$ at $t = t_1$ and, by induction, obtain a process $\{x(t)\}_{t_0-r \leq t \leq T}$ that is a solution of (5.1.1) on $[t_0, T]$, i.e., a process $\{x(t)\}_{t_0-r \leq t \leq T}$ satisfying (i)-(iv) in Definition 5.1.2. Redefine

$$x(t_1) = x(t_1^-) + I_{j_1}(t_1, x_{t_1^-}).$$

It follows from measurability of I that $x(t_1)$ is \mathcal{F}_{t_1} -measurable and hence, by Lemma 5.1.1, $\{x_t\}_{t_0 \leq t \leq t_1}$ is \mathcal{F}_t -adapted. Particularly, x_{t_1} is a \mathcal{PC} -valued \mathcal{F}_{t_1} -measurable random variable. Repeat the argument for existence on $[t_0, t_1]$, we can obtain a process $\{x(t)\}_{t_1 \leq t \leq t_2}$ that is continuous on $[t_1, t_2]$, \mathcal{F}_t -adapted, and satisfies

$$x(t) = x(t_1) + \int_{t_1}^t f_{\sigma(s)}(s, x_s) ds + \int_{t_1}^t g_{\sigma(s)}(s, x_s) dW(s), \quad t \in [t_1, t_2].$$

Redefining $x(t_2)$ to satisfy the impulse relation, repeating this procedure and by induction on the impulse times t_k , $k = 1, 2, \dots, m$, between $[t_0, T]$, we can find processes $\{x(t)\}_{t_k \leq t \leq t_{k+1}}$, $k = 0, 1, 2, \dots, m-1$, such that

$$x(t) = x(t_k) + \int_{t_k}^t f_{\sigma(s)}(s, x_s) ds + \int_{t_k}^t g_{\sigma(s)}(s, x_s) dW(s), \quad t \in [t_k, t_{k+1}),$$

and

$$x(t_k) = x(t_k^-) + I_{j_k}(t_k, x_{t_k^-}),$$

both of which hold for $k = 1, 2, \dots, m-1$. If $t_m = T$ is also an impulse and switching time, then $x(T)$ has to be redefined to satisfy the impulse relation as well, i.e.,

$$x(T) = x(T^-) + I_{j_m}(T, x_{T^-}).$$

Piecing together these processes, we obtain $\{x(t)\}_{t_0-r \leq t \leq T}$, which can be verified to satisfy (i)-(iv) of Definition 5.1.2 on $[t_0, T]$, i.e., $\{x(t)\}_{t_0-r \leq t \leq T}$ is a solution to system (5.1.1) on $[t_0, T]$. The proof is complete. \square

Theorem 5.1.2 *Suppose that conditions (i)-(iii) of Theorem 5.1.1 hold. In addition, assume that $\xi \in \mathcal{L}_{\mathcal{F}_{t_0}}^p$, for some $p \geq 2$, and*

$$\mathbb{E} \{ \|\phi\|^p \} < \infty \quad \text{implies} \quad \mathbb{E} \{ |\phi(0) + I_j(t, \phi)|^p \} < \infty, \quad (5.1.15)$$

for all $j \in \mathcal{J}$, $t \in \mathcal{R}^+$, and $\phi \in \mathcal{L}_{\mathcal{F}_t}^p$. Then

$$\mathbb{E} \{ \|x_t\|^p \} < \infty, \quad \forall t \in [t_0, T].$$

Proof. Keep the same notation as in the proof of Theorem 5.1.1. We shall prove the conclusion by induction. First we show that

$$\mathbb{E} \{ \|x_t\|^p \} < \infty, \quad t \in [t_0, t_1].$$

For each integer $n \geq 1$, define a stopping time

$$\tau_n = t_1 \wedge \inf \{ t \in [t_0, t_1] : \|x_t\| \geq n \}.$$

It is easy to see that τ_n is increasing and $\tau_n \rightarrow t_1$ a.s. as $n \rightarrow \infty$. Set $x^{(n)}(t) = x(t \wedge \tau_n)$ for $t \in [t_0 - r, t_1]$. We have

$$x^{(n)}(t) = \xi(t_0) + \int_{t_0}^t f_{\sigma(s)}(s, x_s^{(n)}) \chi_{[t_0, \tau_n]}(s) ds + \int_{t_0}^t g_{\sigma(s)}(s, x_s^{(n)}) \chi_{[t_0, \tau_n]}(s) dW(s), \quad (5.1.16)$$

where $\chi_{[t_0, \tau_n]}(s) = 1$ for $s \in [t_0, \tau_n]$, and $\chi_{[t_0, \tau_n]}(s) = 0$ otherwise. By virtue of Hölder's inequality, the linear growth condition (5.1.5), and (5.1.16), we have, for $t \in [t_0, t_1]$,

$$\begin{aligned} \mathbb{E} \{ \|x_t^{(n)}\|^p \} &= \mathbb{E} \left\{ \sup_{t-r \leq s \leq t} |x^{(n)}(s)|^p \right\} \\ &\leq 3^{p-1} \mathbb{E} \{ \|\xi\|^p \} + 3^{p-1} \mathbb{E} \left\{ \sup_{t_0 \vee (t-r) \leq s \leq t} \left| \int_{t_0}^s f_{\sigma(s)}(s, x_s^{(n)}) ds \right|^p \right\} \\ &\quad + 3^{p-1} \mathbb{E} \left\{ \sup_{t_0 \vee (t-r) \leq s \leq t} \left| \int_{t_0}^s g_{\sigma(s)}(s, x_s^{(n)}) dW(s) \right|^p \right\}, \quad (5.1.17) \end{aligned}$$

where, by Hölder's inequality and the linear growth condition (5.1.5),

$$\begin{aligned} \mathbb{E} \left\{ \sup_{t_0 \vee (t-r) \leq s \leq t} \left| \int_{t_0}^s f_{\sigma(s)}(s, x_s^{(n)}) ds \right|^p \right\} &\leq \mathbb{E} \left\{ \int_{t_0}^t |f_{\sigma(s)}(s, x_s^{(n)})| ds \right\}^p \\ &\leq (t_1 - t_0)^{\frac{p}{2}} \mathbb{E} \left\{ \int_{t_0}^t |f_{\sigma(s)}(s, x_s^{(n)})|^2 ds \right\}^{\frac{p}{2}} \\ &\leq (t_1 - t_0)^{\frac{p}{2}} \mathbb{E} \left\{ \int_{t_0}^t K^2 (1 + \|x_s^{(n)}\|^2) ds \right\}^{\frac{p}{2}} \end{aligned}$$

$$\begin{aligned} &\leq (t_1 - t_0)^{\frac{p}{2}} K^p \left[2^{\frac{p}{2}-1} (t_1 - t_0)^{\frac{p}{2}} + 2^{\frac{p}{2}-1} \mathbb{E} \left\{ \int_{t_0}^t \|x_s^{(n)}\|^2 ds \right\}^{\frac{p}{2}} \right] \\ &\leq (t_1 - t_0)^{\frac{p}{2}} K^p \left[2^{\frac{p}{2}-1} (t_1 - t_0)^{\frac{p}{2}} + 2^{\frac{p}{2}-1} (t_1 - t_0)^{\frac{p}{2}-1} \int_{t_0}^t \mathbb{E} \{ \|x_s^{(n)}\|^p \} ds \right], \end{aligned}$$

and, by the Burkholder-Davis-Gundy inequality and the linear growth condition (5.1.5),

$$\begin{aligned} \mathbb{E} \left\{ \sup_{t_0 \vee (t-r) \leq s \leq t} \left| \int_{t_0}^s g_{\sigma(s)}(s, x_s^{(n)}) dW(s) \right|^p \right\} &\leq C_p \mathbb{E} \left\{ \int_{t_0}^t |g_{\sigma(s)}(s, x_s^{(n)})|^2 ds \right\}^{\frac{p}{2}} \\ &\leq C_p K^p 2^{\frac{p}{2}-1} \left[(t_1 - t_0)^{\frac{p}{2}} + (t_1 - t_0)^{\frac{p}{2}-1} \int_{t_0}^t \mathbb{E} \{ \|x_s^{(n)}\|^p \} ds \right], \end{aligned}$$

where C_p is a constant that depends only on p . Hence, (5.1.17) reduces to

$$\mathbb{E} \{ \|x_t^{(n)}\|^p \} \leq \kappa_1 + \kappa_2 \int_{t_0}^t \mathbb{E} \{ \|x_s^{(n)}\|^p \} ds, \quad t \in [t_0, t_1), \quad (5.1.18)$$

where

$$\kappa_1 = 3^{p-1} \left[\mathbb{E} \{ \|\xi\|^p \} + K^p (t_1 - t_0)^p + C_p 2^{\frac{p}{2}-1} K^p (t_1 - t_0)^{\frac{p}{2}} \right] < \infty,$$

and

$$\kappa_2 = 3^{p-1} 2^{\frac{p}{2}-1} K^p \left[(t_1 - t_0)^{p-1} + C_p (t_1 - t_0)^{\frac{p}{2}-1} \right] < \infty.$$

By Gronwall's inequality, (5.1.18) implies that

$$\mathbb{E} \{ \|x_t^{(n)}\|^p \} \leq \kappa_1 e^{\kappa_2(t-t_0)}, \quad t \in [t_0, t_1),$$

which, by letting $n \rightarrow \infty$, yields that

$$\mathbb{E} \{ \|x_t\|^p \} \leq \kappa_1 e^{\kappa_2(t-t_0)}, \quad t \in [t_0, t_1).$$

Consequently, $\mathbb{E} \{ \|x_t\|^p \} < \infty$ for all $t \in [t_0, t_1)$ and $\mathbb{E} \{ \|x_{t_1^-}\|^p \} < \infty$. At $t = t_1$, it follows from (5.1.15) that

$$\begin{aligned} \mathbb{E} \{ \|x_{t_1}\|^p \} &= \mathbb{E} \left\{ \sup_{t_1-r \leq s \leq t_1} |x^{(n)}(t)|^p \right\} \\ &\leq \mathbb{E} \left\{ |x(t_1)|^p \vee \|x_{t_1^-}\|^p \right\} \\ &= \mathbb{E} \left\{ |x(t_1^-) + I_{j_1}(t_1, x_{t_1^-})|^p \vee \|x_{t_1^-}\|^p \right\} \\ &\leq \mathbb{E} \left\{ |x(t_1^-) + I_{j_1}(t_1, x_{t_1^-})|^p \right\} + \mathbb{E} \{ \|x_{t_1^-}\|^p \} < \infty. \end{aligned}$$

Repeating the same argument on $[t_k, t_{k+1}]$, $k = 1, 2, \dots, m - 1$, we obtain the required conclusion that $E\{\|x_t\|^p\} < \infty$ for all $t \in [t_0, T]$. The proof is complete. \square

Corollary 5.1.1 *Suppose that conditions (i)-(iii) in Theorem 5.1.1 hold for each $T > 0$. Then there exists a unique solution to system (5.1.1) on $[t_0, \infty)$. If, in addition, (5.1.15) is satisfied and $\xi \in \mathcal{L}_{\mathcal{F}_{t_0}}^p$, for some $p \geq 2$, then $E\{\|x_t\|^p\} < \infty$ for all $t \geq t_0$.*

Remark 5.1.1 For $0 < p < 2$, Hölder's inequality implies that $E\{\|x_t\|^p\} \leq [E\{\|x_t\|^2\}]^{\frac{p}{2}}$. Therefore, if (5.1.15) holds and $\xi \in \mathcal{L}_{\mathcal{F}_{t_0}}^2$, Theorem 5.1.2 also implies that $E\{\|x_t\|^p\} < \infty$, where $0 < p < 2$. Particularly, if $\xi \in \mathcal{L}_{\mathcal{F}_{t_0}}^b$, then $E\{\|x_t\|^p\} < \infty$ for all $p > 0$, which implies that the solution to system (5.1.1) has finite moments of any order. \square

Remark 5.1.2 The Lipschitz condition (5.1.4) in Theorem 5.1.4 can be replaced by the following local Lipschitz condition: for each integer $n \geq 1$,

$$|f_i(t, \phi) - f_i(t, \psi)| + |g_i(t, \phi) - g_i(t, \psi)| \leq K_n \|\phi - \psi\|, \quad (5.1.19)$$

holds for all $(t, \phi, \psi) \in [t_0, T] \times \mathcal{PC} \times \mathcal{PC}$, $i \in \mathcal{I}$, and $\|\phi\| \vee \|\psi\| \leq n$, where K_n is a constant depending on n . The proof for uniqueness remains the same, while the existence can be proved by the standard truncation procedure (see, e.g., [53] or [140]). \square

Remark 5.1.3 Following the idea of [79], it is possible to establish some existence results for system (5.1.1) under the condition that the initial data ξ satisfies $E\{\|\xi\|^4\} < \infty$. However, this type of results are not desirable due to the impulse effects - even if the initial data ξ satisfies this moment condition, it cannot be guaranteed that the fourth moment of the solution is still finite after a certain impulse. For existence and uniqueness results on continuous stochastic functional or delay differential equations without impulses, see, e.g., [140] and [143]. \square

Remark 5.1.4 The condition that f_i and g_i are composite-PC is to guarantee that the integrals in question, such as $\int_{t_0}^t f_i(s, x_s) ds$ and $\int_{t_0}^t g_i(s, x_s) ds$, are well-defined. This extra composite-PC condition is needed for impulsive delay differential equations, since x_t as a \mathcal{PC} -valued function of t is generally not even piecewise continuous [9], whereas, for a continuous function x , x_t as a $C([-r, 0]; \mathcal{R}^n)$ -valued function is continuous (and hence measurable) with respect to t . Here, however, the composite-PC condition can be replaced by a weaker one, i.e., that the composite functions $f_i(s, x_s)$ and $g_i(s, x_s)$ are integrable with respect to t (one could call this condition a **composite-integrable** condition). \square

Remark 5.1.5 As a special case of system (5.1.1) without switching, Theorem 5.1.1, Theorem 5.1.2, and Corollary 5.1.1 clearly can be applied to the following impulsive stochastic functional (delay) differential system described by (5.3.1) in Section 5.3. Moreover, if we only consider the switched stochastic delay system (5.1.3), Remark 5.1.4 above shows that the composite-PC conditions on f_i and g_i can be dropped, since the solution of a system (5.1.3) is a \mathcal{C} -valued process instead of a \mathcal{PC} -valued process. Therefore, the composite functions $f_i(t, x_t)$ and $g_i(t, x_t)$ are both measurable with respect to t . \square

5.2 Multiple Lyapunov Functions and Itô's Formula

Before we move on to the stability analysis of stochastic hybrid systems, we give a brief account on the method of multiple Lyapunov functions and Itô's formula¹, which are the key tools to be used later in this chapter.

The following definition generalizes the definition given by (2.3.1) on the derivatives of multiple Lyapunov functions along solutions of subsystems of deterministic switched ordinary systems to stochastic switched systems with time-delay.

Definition 5.2.1 Let $\mathcal{C}^{1,2} = \mathcal{C}^{1,2}(\mathcal{R} \times \mathcal{R}^n; \mathcal{R}^n)$ denote the set of all functions from $\mathcal{R} \times \mathcal{R}^n$ to \mathcal{R} that are continuously differentiable in the first variable and twice continuously differentiable in the second variable. Suppose that $\{V_i; i \in \mathcal{I}\}$ is a family of functions in $\mathcal{C}^{1,2}$. For each $i \in \mathcal{I}$, define an operator from $\mathcal{R} \times \mathcal{PC}$ to \mathcal{R} , corresponding to the i th mode of (5.1.1a), by

$$\mathcal{L}V_i(t, \phi) = V_t^i(t, \phi(0)) + V_x^i(t, \phi(0))f_i(t, \phi) + \frac{1}{2}\text{trace}[g_i^T(t, \phi)V_{xx}^i(t, \phi(0))g_i(t, \phi)],$$

where V_t^i , V_x^i , and V_{xx}^i are functions from $\mathcal{R}^+ \times \mathcal{R}^n$ defined by

$$V_t^i(t, x) = \frac{\partial V_i(t, x)}{\partial t}, \quad V_x^i(t, x) = \left(\frac{\partial V_i(t, x)}{\partial x_1}, \dots, \frac{\partial V_i(t, x)}{\partial x_n} \right),$$

$$V_{xx}^i(t, x) = \left(\frac{\partial^2 V_i(t, x)}{\partial x_i \partial x_j} \right)_{n \times n}. \quad \square$$

The definition of the operators $\mathcal{L}V_i$ is stimulated by the well-known formula due to Itô (see, e.g., [140, p.36, Chapter 1]). Instead of presenting the general Itô's formula, we apply

¹Itô's Lemma is currently also referred to as the Itô-Doebelin Theorem in recognition of the recently discovered work of Wolfgang Doebelin (1915–1940) [22].

Itô's formula to our system (5.1.1) together with a family of multiple Lyapunov functions candidates $\{V_i : i \in \mathcal{I}\}$ in $\mathcal{C}^{1,2}$ and obtain the following lemma in view of the operators \mathcal{L}_i defined by Definition 5.2.1.

Lemma 5.2.1 (Itô's Formula) *Let $x(t)$ be an n -dimensional stochastic process defined on $[t_0, T]$ that solves system (5.1.1) with $\{(t_k, i_k, j_k)\}$ as a particular impulsive switching signal. Let $\{V_i : i \in \mathcal{I}\}$ be a family of functions in $\mathcal{C}^{1,2}$. Then we have*

$$V_{i_k}(t, x(t)) = V_{i_k}(s, x(s)) + \int_s^t \mathcal{L}V_{i_k}(\tau, x(\tau))d\tau + \int_s^t V_{x^{i_k}}^{i_k}(\tau, x(\tau))g_{i_k}(\tau, x(\tau))dW(\tau),$$

for all $s, t \in [t_k, t_{k+1})$.

Taking expectation from both sides of the equation in Lemma 5.2.1 and using properties of Itô integral, we get

$$\mathbb{E}\{V_{i_k}(t, x(t))\} = \mathbb{E}\{V_{i_k}(s, x(s))\} + \int_s^t \mathbb{E}\{\mathcal{L}V_{i_k}(\tau, x(\tau))\}d\tau, \quad (5.2.1)$$

for all $s, t \in [t_k, t_{k+1})$. This relation shall play a key role in applying multiple Lyapunov functions to study stability properties of system (5.1.1). It is also evident from equation (5.2.1) that the operators $\mathcal{L}V_i$ for stochastic hybrid systems are the counterpart of \dot{V}_i or D^+V_i for deterministic hybrid systems, and will play an equally important role in subsequent analysis.

5.3 Impulsive Stabilization of Stochastic Delay Systems

5.3.1 Mathematical Formulation

Consider the following impulsive stochastic functional differential system:

$$\begin{cases} dx(t) = f(t, x_t)dt + g(t, x_t)dW(t), & t \neq t_k, \quad t \geq t_0, & (5.3.1a) \\ \Delta x(t) = I(t, x_{t-}), & t = t_k, & (5.3.1b) \\ x_{t_0} = \xi, & & (5.3.1c) \end{cases}$$

where $\{t_k : k \in \mathcal{Z}^+\}$ is a strictly increasing sequence such that $t_k \rightarrow \infty$ as $k \rightarrow \infty$, called the **impulse times**. Other notations are the same as described in Section 5.1. It is assumed that f , g , and I satisfy assumptions in Theorems 5.1.1 and 5.1.2 so that, for any initial data $\xi \in \mathcal{L}_{\mathcal{F}_{t_0}}^b$, system (5.3.1) has a unique global solution, denoted by $x(t; \xi)$, and, moreover,

$x(t; \xi) \in \mathcal{L}_{\mathcal{F}_t}^p$ for all $t \geq t_0$ and $p > 0$. In addition, it is assumed that $f(t, 0) \equiv 0$, $g(t, 0) \equiv 0$, and $I(t, 0) \equiv 0$, for all $t \in [0, \infty)$, so that system (5.3.1) admits a trivial solution.

The main objective of this section is to find conditions such that, even if the continuous dynamics given by (5.3.1a) is highly unstable, the impulse control, introduced by (5.3.1b), can successfully stabilize system (5.3.1). Both moment stability and almost sure stability will be considered, which are formulated in the following definition.

Definition 5.3.1 For $p > 0$, the trivial solution of system (5.3.1) is said to be ***p*th moment globally uniformly exponentially stable (GUES)**, if, for any initial data $\xi \in \mathcal{L}_{\mathcal{F}_{t_0}}^b$, the solution $x(t; \xi)$ satisfies

$$\mathbb{E} \{|x(t; \xi)|^p\} \leq C \mathbb{E} \{\|\xi\|^p\} e^{-\varepsilon(t-t_0)}, \quad t \geq t_0, \quad (5.3.2)$$

where ε and C are positive constants independent of t_0 . It follows from (5.3.2) that

$$\limsup_{t \rightarrow \infty} \frac{1}{t} \log \mathbb{E} \{|x(t; \xi)|^p\} \leq -\varepsilon. \quad (5.3.3)$$

The left-hand side of (5.3.3) is called the ***p*th moment Lyapunov exponent** for the solution. Moreover, define

$$\limsup_{t \rightarrow \infty} \frac{1}{t} \log |x(t; \xi)| \quad (5.3.4)$$

to be the ***Lyapunov exponent*** of the solution. The trivial solution of system (5.3.1) is said to be ***almost surely exponentially stable*** if the Lyapunov exponent is almost surely negative for any $\xi \in \mathcal{L}_{\mathcal{F}_{t_0}}^b$. \square

Since there is no switching in (5.3.1), we shall use a single Lyapunov function V in $\mathcal{C}^{1,2}$, and the operator $\mathcal{L}V$ reduces to

$$\mathcal{L}V(t, \phi) = V_t(t, \phi(0)) + V_x(t, \phi(0))f(t, \phi) + \frac{1}{2} \text{trace}[g^T(t, \phi) V_{xx}(t, \phi(0))g(t, \phi)].$$

5.3.2 Moment Exponential Stability

We first investigate the *p*th moment exponential stability of system (5.3.1). It is shown that, even if the *p*th moment of a stochastic delay system are unstable, the impulsive control can effectively stabilize the system and achieve *p*th moment global exponential stability.

Theorem 5.3.1 Let $\Lambda, p, c_1, c_2, \rho < 1, \delta$, and $\bar{\mu}$ be positive constants. Suppose that

- (i) there exists a function $V \in \mathcal{C}^{1,2}$ such that $c_1 |x|^p \leq V(t, x) \leq c_2 |x|^p$, for $(t, x) \in [t_0 - r, \infty) \times \mathcal{R}^n$,

(ii) there exists a nonnegative and piecewise continuous function $\mu : [t_0, \infty) \rightarrow \mathcal{R}^+$, satisfying $\int_t^{t+\delta} \mu(s) ds \leq \bar{\mu}\delta$ for all $t \geq t_0$, such that

$$\mathbb{E}\{\mathcal{L}V(t, \phi)\} \leq \mu(t) \mathbb{E}\{V(t, \phi(0))\}, \quad (5.3.5)$$

whenever $t \geq t_0$ and $\phi \in \mathcal{L}_{\mathcal{F}_t}^p$ are such that $\mathbb{E}\{V(t+s, \phi(s))\} \leq q \mathbb{E}\{V(t, \phi(0))\}$, for all $s \in [-r, 0]$, where q is a constant such that $q \geq \exp(\Lambda r + \Lambda\delta + \bar{\mu}\delta)$,

(iii) there exist positive constants d_k , with $\prod_{k=1}^{\infty} d_k < \infty$, such that

$$\mathbb{E}\{V(t_k, \phi(0) + I(t_k, \phi))\} \leq \rho d_k \mathbb{E}\{V(t_k^-, \phi(0))\}, \quad (5.3.6)$$

for $k \in \mathcal{Z}^+$ and $\phi \in \mathcal{L}_{\mathcal{F}_t}^p$, and

(iv) $\sup_{k \in \mathcal{Z}^+} \{t_k - t_{k-1}\} = \delta < -\frac{\ln(\rho)}{\Lambda + \bar{\mu}}$.

Then the trivial solution of system (5.3.1) is p th moment globally uniformly exponentially stable and its p th moment Lyapunov exponent is not greater than $-\Lambda$.

Proof. Given any initial data $\xi \in \mathcal{L}_{\mathcal{F}_{t_0}}^b$, the global solution $x(t; \xi)$ of (5.3.1) is written as $x(t)$ in this proof. Without loss of generality, assume that the initial data ξ is nontrivial so that $x(t)$ is not a trivial solution. Let $v(t) = \mathbb{E}\{V(t, x(t))\}$, for $t \geq t_0 - r$, and $\tilde{\Lambda} = \Lambda - \eta$, where $\eta > 0$ being an arbitrary number such that $\tilde{\Lambda} > 0$. It is clear that $v(t)$ is right-continuous for $t \geq t_0$. Choose $M \in (e^{(\Lambda + \bar{\mu})\delta}, qe^{\Lambda\delta})$ so that

$$\|v_{t_0}\| < M\|v_{t_0}\|e^{-(\Lambda + \bar{\mu})\delta} < M\|v_{t_0}\|e^{-\Lambda\delta} < q\|v_{t_0}\|, \quad (5.3.7)$$

where $\|v_{t_0}\| = \max_{-r \leq s \leq 0} v(t_0 + s)$. We will show that

$$v(t) \leq M\|v_{t_0}\|e^{-\tilde{\Lambda}(t_1 - t_0)}, \quad \forall t \in [t_0, t_1], \quad (5.3.8)$$

by proving a stronger claim:

$$v(t) \leq M\|v_{t_0}\|e^{-\Lambda\delta}, \quad \forall t \in [t_0, t_1]. \quad (5.3.9)$$

Suppose (5.3.9) is not true and observe that

$$v(t) \leq \|v_{t_0}\| < M\|v_{t_0}\|e^{-\Lambda\delta}, \quad (5.3.10)$$

holds on $[t_0 - r, t_0]$. Define $t^* = \inf\{t \in [t_0, t_1] : v(t) > M\|v_{t_0}\|e^{-\Lambda\delta}\}$. Then $t^* \in (t_0, t_1)$ and, by continuity of $v(t)$,

$$v(t) \leq v(t^*) = M\|v_{t_0}\|e^{-\Lambda\delta}, \quad \forall t \in [t_0, t^*]. \quad (5.3.11)$$

In view of (5.3.10), define $t_* = \sup \{t \in [t_0, t^*) : v(t) \leq \|v_{t_0}\|\}$. Then $t_* \in [t_0, t^*)$ and, by continuity of $v(t)$,

$$v(t) \geq v(t_*) = \|v_{t_0}\|, \quad \forall t \in [t_*, t^*]. \quad (5.3.12)$$

Now in view of (5.3.7), (5.3.11), and (5.3.12), one has, for $t \in [t_*, t^*]$ and $s \in [-r, 0]$,

$$v(t+s) \leq v(t^*) = M\|v_{t_0}\|e^{-\Lambda\delta} < q\|v_{t_0}\| \leq qv(t).$$

By the Razumikhin-type condition (ii), one has

$$\mathbb{E}\{\mathcal{L}V(t, x_t)\} \leq \mu(t) \mathbb{E}\{V(t, x(t))\}, \quad \forall t \in [t_*, t^*]. \quad (5.3.13)$$

Applying Itô's fomula on $[t_*, t^*]$ and by (5.3.13), one obtains that

$$\begin{aligned} & e^{\int_{t_0}^{t^*} \mu(\tau) d\tau} v(t^*) - e^{\int_{t_0}^{t_*} \mu(\tau) d\tau} v(t_*) \\ &= \int_{t_*}^{t^*} e^{\int_{t_0}^s \mu(\tau) d\tau} [\mathbb{E}\{\mathcal{L}V(s, x_s)\} - \mu(s) \mathbb{E}\{V(s, x(s))\}] ds \\ &\leq 0, \end{aligned}$$

which implies

$$v(t^*) \leq v(t_*) e^{\int_{t_*}^{t^*} \mu(s) ds} \leq v(t_*) e^{\bar{\mu}\delta}. \quad (5.3.14)$$

Since (5.3.14) contradicts what is implied by (5.3.7), (5.3.11), and (5.3.12), claim (5.3.9) must be true and so is (5.3.8).

Now, assume that

$$v(t) \leq M_k \|v_{t_0}\| e^{-\tilde{\Lambda}(t_k - t_0)}, \quad \forall t \in [t_{k-1}, t_k], \quad (5.3.15)$$

for all $k \leq m$, where $k, m \in \mathcal{Z}^+$ and M_k is defined as $M_1 = M$ and $M_k = M \prod_{1 \leq l \leq k-1} d_l$, for $k \geq 2$. We proceed to show that

$$v(t) \leq M_{m+1} \|v_{t_0}\| e^{-\tilde{\Lambda}(t_{m+1} - t_0)}, \quad \forall t \in [t_m, t_{m+1}], \quad (5.3.16)$$

by proving a stronger claim:

$$v(t) \leq M_{m+1} \|v_{t_0}\| e^{-\tilde{\Lambda}[(t_m - t_0) + \delta]}, \quad \forall t \in [t_m, t_{m+1}]. \quad (5.3.17)$$

From (5.3.15) and (5.3.6), one has

$$v(t_m) \leq \rho d_m v(t_m^-) \leq \rho d_m M_m \|v_{t_0}\| e^{-\tilde{\Lambda}(t_m - t_0)} = \rho M_{m+1} \|v_{t_0}\| e^{-\tilde{\Lambda}(t_m - t_0)},$$

which implies

$$v(t_m) < e^{-\bar{\mu}\delta} M_{m+1} \|v_{t_0}\| e^{-\tilde{\Lambda}[(t_m-t_0)+\delta]}. \quad (5.3.18)$$

Choose $\varepsilon > 0$ sufficiently small such that

$$v(t_m) < e^{-\bar{\mu}\delta-\varepsilon} M_{m+1} \|v_{t_0}\| e^{-\tilde{\Lambda}[(t_m-t_0)+\delta]} < e^{-\bar{\mu}\delta} M_{m+1} \|v_{t_0}\| e^{-\tilde{\Lambda}[(t_m-t_0)+\delta]}. \quad (5.3.19)$$

Suppose claim (5.3.17) is not true. Define

$$\bar{t} = \inf \left\{ t \in [t_m, t_{m+1}) : v(t) > M_{m+1} \|v_{t_0}\| e^{-\tilde{\Lambda}[(t_m-t_0)+\delta]} \right\}.$$

In view of (5.3.18), one has $\bar{t} \in (t_m, t_{m+1})$ and, by continuity of $v(t)$,

$$v(t) \leq v(\bar{t}) = M_{m+1} \|v_{t_0}\| e^{-\tilde{\Lambda}[(t_m-t_0)+\delta]}, \quad \forall t \in [t_m, \bar{t}]. \quad (5.3.20)$$

In view of (5.3.19), define

$$\underline{t} = \sup \left\{ t \in [t_m, \bar{t}) : v(t) \leq e^{-\bar{\mu}\delta-\varepsilon} M_{m+1} \|v_{t_0}\| e^{-\tilde{\Lambda}[(t_m-t_0)+\delta]} \right\}.$$

Then $\underline{t} \in (t_m, \bar{t})$ and, by continuity of $v(t)$,

$$v(t) \geq v(\underline{t}) = e^{-\bar{\mu}\delta-\varepsilon} M_{m+1} \|v_{t_0}\| e^{-\tilde{\Lambda}[(t_m-t_0)+\delta]} = e^{-\bar{\mu}\delta-\varepsilon} v(\bar{t}), \quad (5.3.21)$$

for all $t \in [\underline{t}, \bar{t}]$. Now for $t \in [\underline{t}, \bar{t}]$ and $s \in [-r, 0]$, from (5.3.15), (5.3.21), and the fact that $q \geq \exp(\Lambda r + \Lambda \delta + \bar{\mu}\delta)$ and $t + s \in [t_{m-1}, \bar{t}]$, one has

$$v(t + s) \leq M_{m+1} \|v_{t_0}\| e^{-\tilde{\Lambda}(t+s-t_0)} \leq e^{\tilde{\Lambda}r + \tilde{\Lambda}\delta + \bar{\mu}\delta + \varepsilon} v(\underline{t}) \leq qv(t),$$

provided that ε defined in (5.3.19) is chosen sufficiently small. Similar to the argument on $[t_*, t^*]$, an application of Itô's formula on $[\underline{t}, \bar{t}]$ will lead to $v(\bar{t}) \leq v(\underline{t})e^{\bar{\mu}\delta}$, which would contradict (5.3.21). Therefore, claim (5.3.17) must be true and so is (5.3.16). By induction on m and the definition of M_m , one can conclude that

$$v(t) \leq M \prod_{\{k: t_0 < t_k \leq t\}} d_k \|v_{t_0}\| e^{-\tilde{\Lambda}(t-t_0)}, \quad \forall t \geq t_0.$$

By condition (i) and the facts that $\hat{d} = \prod_{k=1}^{\infty} d_k < \infty$ and $\eta > 0$ is arbitrary and independent of t , we actually have shown

$$\mathbb{E} \{ |x(t)|^p \} \leq M \hat{d} \frac{c_2}{c_1} \mathbb{E} \{ \|\xi\|^p \} e^{-\Lambda(t-t_0)}, \quad \forall t \geq t_0,$$

which shows that the trivial solution of (5.3.1) is p th moment GUES, with its p th moment Lyapunov exponent not greater than $-\Lambda$. \square

Remark 5.3.1 It is clear that Theorem 5.3.2 allows the continuous dynamics of system (5.3.1) to be unstable, since the function $\mu(t)$ in (5.3.5), which characterizes the changing rate of $V(t, x(t))$ at t , is assumed to be nonnegative. Theorem 5.3.1 shows that an unstable stochastic delay system can be successfully stabilized by impulses. \square

Remark 5.3.2 The only condition in Theorem 5.3.1 that involves the delay size r is condition (ii), where q is required to satisfy

$$q \geq \exp(\Lambda r + \Lambda \delta + \bar{\mu} \delta), \quad (5.3.22)$$

with $\bar{\mu}$ usually being a quantity depending on q due to the Razumikhin-type condition. To apply the theorem, it is required that (5.3.22) as an inequality of q has at least one solution. When r becomes larger (while Λ can still be arbitrarily chosen but fixed), δ has to become sufficiently small to guarantee that (5.3.22) has a solution, i.e., the impulse frequency has to reach a certain level to cope with the increase in time-delay, which is reasonable. Based on this observation, Theorem 5.3.1 can be easily applied to system with arbitrarily large delays. \square

Remark 5.3.3 In the condition (5.3.6), the constants d_k make it possible to tolerate certain perturbations in the overall impulsive stabilization process, i.e., it is not strictly required by Theorem 5.3.1 that each impulse contributes to stabilize the system, as long as the overall contribution of the impulses are stabilizing. Without these d_k (i.e., $d_k \equiv 1$), it is required that each impulse is a stabilizing factor ($\rho < 1$), which is more restrictive. \square

5.3.3 Almost Sure Exponential Stability

The following theorem shows that the trivial solution of system (5.3.1) is also almost surely exponentially stable, under some additional conditions.

Theorem 5.3.2 *Suppose that $p \geq 1$ and the same conditions as in Theorems 5.3.1 hold. Moreover, there exists a constant $K > 0$ such that*

$$\mathbb{E} \{ |f(t, \phi)|^p \vee |g(t, \phi)|^p \vee |I(t, \phi)|^p \} \leq K \sup_{-r \leq s \leq 0} \mathbb{E} \{ |\phi(s)|^p \}, \quad (5.3.23)$$

and there exists a positive integer N such that there are at most N impulse times within any interval of length r . Then the trivial solution of system (5.3.1) is also almost surely exponentially stable, with its Lyapunov exponent not greater than $-\Lambda/p$.

This theorem can be proved as a special case of a more general result given by Theorem 5.5.4.

5.3.4 Linear Systems

Now consider the linear impulsive stochastic delay system

$$\begin{cases} dx(t) = [Ax(t) + Bx(t - \hat{r})]dt + [Cx(t) + Dx(t - \hat{r})]dW(t), & t \neq t_k, \\ \Delta x(t) = E_k x(t^-), & t = t_k, \end{cases} \quad (5.3.24)$$

where A, B, C, D , and E_k are all $n \times n$ matrices and W is a one-dimensional standard Wiener process. A single time-varying delay is given by $\hat{r} = r(t)$, which is continuous on \mathcal{R}^+ and satisfies $0 \leq \hat{r} \leq r$, for some constant $r > 0$. The initial data is omitted, but it is assumed to be in $\mathcal{L}_{\mathcal{F}_{t_0}}^b$.

Theorem 5.3.3 *If there exist constants $p \geq 2$, $\Lambda > 0$, and $q > 1$ such that $q \geq \exp(\Lambda r + \Lambda \delta + \mu \delta)$, where $\mu = \kappa + \tilde{\kappa} q > 0$ with*

$$\begin{aligned} \kappa = & \frac{p}{2} \lambda_{\max}(A^T + A) + \frac{p}{2} \|B\| + \frac{p(\mathcal{I} - 1)}{2} \|C\|^2 + (\mathcal{I} - 1)^2 \|C\| \|D\| \\ & + \frac{(\mathcal{I} - 1)(\mathcal{I} - 2)}{2} \|D\|^2, \end{aligned}$$

$$\tilde{\kappa} = \|B\| + (\mathcal{I} - 1) \|C\| \|D\| + (\mathcal{I} - 1) \|D\|^2,$$

and

$$\log(\|I + E_k\|) < -\frac{1}{2}(\Lambda + \mu)\delta + \ln d_k, \quad \forall k \in \mathcal{Z}^+,$$

where $\delta = \sup_{k \in \mathcal{Z}^+} \{t_k - t_{k-1}\}$, $d_k > 0$, and $\prod_{k=1}^{\infty} d_k < \infty$, then the trivial solution of (5.1.5) is p th moment GUES, with its p th moment Lyapunov exponent not greater than $-\Lambda$. If, in addition, there are at most N impulse times within any interval of length r , for some fixed integer N , then the trivial solution of system (5.3.24) is also almost surely exponentially stable, with its Lyapunov exponent not greater than $-\Lambda/p$.

Proof. The conclusions follow from Theorems 5.3.1 and 5.3.2 by considering $V(x) = |x|^p$. \square

5.3.5 An Example

Example 5.3.1 Consider the linear impulsive stochastic delay system

$$\begin{cases} dx(t) = [Ax(t) + Bx(t-1)]dt + [Cx(t) + Dx(t-1)]dW(t), & t \neq t_k, \\ \Delta x(t) = E_k x(t^-), & t = t_k, \end{cases} \quad (5.3.25)$$

with $t_k = k/10, k \in \mathcal{Z}^+$,

$$\begin{aligned} A &= \begin{bmatrix} -0.01 & -0.26 & -0.13 \\ -0.16 & 0.14 & 0.17 \\ 0.05 & 0.32 & 0.25 \end{bmatrix}, & B &= \begin{bmatrix} -0.31 & -0.08 & 0.14 \\ -0.28 & 0.13 & 0.25 \\ 0.11 & 0.16 & 0.13 \end{bmatrix}, \\ C &= \begin{bmatrix} 0.23 & -0.03 & -0.21 \\ -0.24 & -0.32 & 0.28 \\ 0 & 0.05 & -0.16 \end{bmatrix}, & D &= \begin{bmatrix} 0.1 & -0.43 & 0.12 \\ 0.04 & -0.01 & 0.1 \\ -0.18 & -0.20 & 0.33 \end{bmatrix}, \\ E_k &= \begin{bmatrix} -0.3 & 0 & 0 \\ 0 & -0.4 & 0 \\ 0 & 0 & -0.3 \end{bmatrix}. \end{aligned}$$

Choosing $p = 2$, then κ and $\tilde{\kappa}$ in Theorem 5.3.3 can be computed to be $\kappa = 2.1255$ and $\tilde{\kappa} = 1.1196$. If we further choose $\Lambda = 0.5$ and $\delta = 0.1$, then there exists $q = 2.9992$ such that $q = \exp(\Lambda r + \Lambda \delta + \mu \delta)$, where $\mu = \kappa + \tilde{\kappa} q = 5.4834$. It is easy to verify that $\log(\|I + E_k\|) = -0.3567 < -0.2992 = -(\Lambda + \mu)\delta/2$. Theorem 5.3.3 guarantees that the trivial solution of system (5.3.25) is second moment GUES, with its second moment Lyapunov exponent not greater than $-\Lambda = -0.5$, and also almost surely exponentially stable, with its Lyapunov exponent not greater than $-\Lambda/2 = -0.25$. Numerical simulations for this example are shown in Figure 5.1. It is clearly demonstrated that impulses can successfully stabilize an otherwise unstable stochastic delay system. \square

5.4 Switching Stabilization of Stochastic Delay Systems

As shown in Section 2.5, a state-dependent switching signal can be constructed to stabilize a family of unstable systems under suitable assumptions on the vector fields of the subsystems. Namely, a linear convex combination of the vector fields has to assume a Lyapunov function.

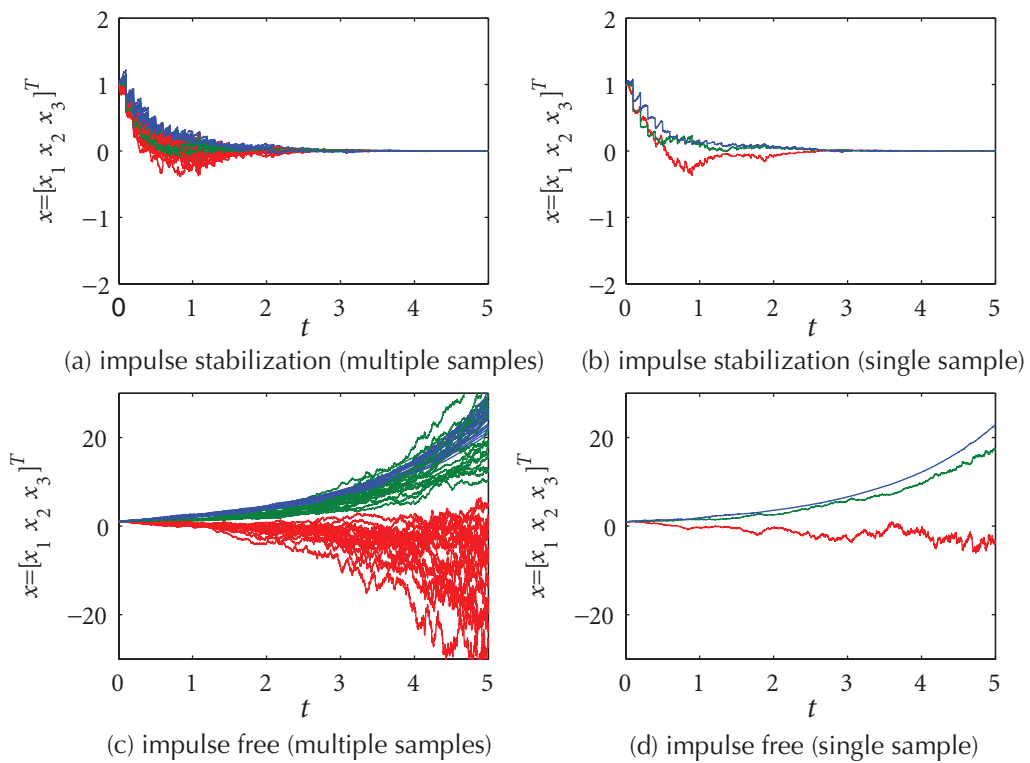

Figure 5.1 Simulation results for Example 5.3.1: (a) impulsive stabilization of system (5.3.1) (multiple samples); (b) impulsive stabilization of system (5.3.1) (single sample); (c) system response without impulses (multiple samples); (d) system response without impulses (single sample).

In the case of switched nonlinear systems, we have further shown that this Lyapunov function does not have to be quadratic, and a generalized rule, which extends the minimal rule as proposed in [182], can be used to avoid chattering and Zeno behavior.

In this section, we will explore the idea of switching stabilization in the stochastic setting. We shall also consider time-delay as studied in [91] and [92] for deterministic switched linear systems. In contrast with Section 2.5, here we focus on systems whose vector fields assume a *quadratic Lyapunov function*. Nevertheless, the results will cover both linear and nonlinear systems.

5.4.1 Mathematical Formulation

Consider the following stochastic uncertain switched system

$$\begin{cases} dx(t) = [(A_\sigma + \Delta A_\sigma(t))x(t) + (B_\sigma + \Delta B_\sigma(t))x(t-r)] dt \\ \quad + g_\sigma(t, x(t), x(t-r))dW(t), \quad t \geq t_0, \\ x_{t_0} = \xi, \end{cases} \quad (5.4.1)$$

where $\sigma : \mathcal{R}^+ \rightarrow \mathcal{I} = \{1, 2, \dots, N\}$ is a switching rule to be constructed and interpreted as a time-dependent function, $x \in \mathcal{R}^n$ is the state, h is a constant time-delay, $W(t)$ is an m -dimensional standard Wiener process, $\xi \in \mathcal{L}_{\mathcal{F}_{t_0}}^b$ is the initial data, $A_i, B_i \in \mathcal{R}^{n \times n}$ are constant real matrices, and $\Delta A_i(t), \Delta B_i(t)$ are bounded but unknown disturbances (uncertainties). We assume $g_i : \mathcal{R}^+ \times \mathcal{R}^n \times \mathcal{R}^n \rightarrow \mathcal{R}^{n \times m}$ satisfies the conditions in Theorems 5.1.1 and 5.1.2 so that, for each $\xi \in \mathcal{L}_{\mathcal{F}_{t_0}}^b$, system (5.4.1) has a unique global solution, denoted by $x(t; \xi)$, and $x(t; \xi) \in \mathcal{L}_{\mathcal{F}_t}^p$ for all $t \geq t_0$ and $p > 0$. We further assume that $g_i(t, 0, 0) \equiv 0$ so that system (5.4.1) yields a trivial solution. We propose the following assumption.

Assumption 5.4.1 For system (5.4.1) defined above, there exists a Hurwitz linear convex combination of $A_i + B_i$, that is

$$H = \sum_{i=1}^N \alpha_i (A_i + B_i), \quad (5.4.2)$$

where $0 < \alpha_i < 1$ and $\sum_{i=1}^N \alpha_i = 1$. □

Under Assumption 5.4.1, there exist positive definite symmetric matrices P and Q which satisfy

$$H^T P + P H = -Q. \quad (5.4.3)$$

Equation (2.4.3) leads immediately to the following lemma.

Lemma 5.4.1 ([91]) *Let P and Q be given by (5.4.3) and define*

$$\Omega_i = \{x \in \mathcal{R}^n : x^T[(A_i + B_i)^T P + P(A_i + B_i)]x \leq -x^T Qx\}.$$

Then $\mathcal{R}^n = \cup_{i=1}^N \Omega_i$.

The proof is similar to that of Proposition 2.5.1.

From Lemma 5.4.1, we can see that if $x \in \Omega_i$, then the quadratic function $V(x) = x^T P x$ decreases along the trajectory of the system

$$\dot{x}(t) = (A_i + B_i)x(t),$$

which is reduced from system (5.4.1) by neglecting uncertainties, stochastic perturbations, and time-delays. This actually gives the intuitive idea behind the stabilizing rule constructed in [182], which was later extended to switch linear delay systems in [91] and [92]. In addition, as already shown in Section 2.5, the idea of hysteresis switching (see, e.g., [107]) is important here to prevent chattering. The hysteresis switching is defined by first enlarging the region Ω_i a little bit to obtain

$$\Omega'_i = \left\{x \in \mathcal{R}^n : x^T[(A_i + B_i)^T P + P(A_i + B_i)]x \leq -\frac{1}{\zeta} x^T Qx\right\},$$

where $\zeta > 1$ can be arbitrarily chosen, then defining a **minimal rule** as follows.

(R₁) Starting from some $t = t_0$, let

$$\sigma(t_0) = \arg \min_i x^T[(A_i + B_i)^T P + P(A_i + B_i)]x,$$

where \arg denotes the value of the argument i such that the minimal is attained;

(R₂) Maintain $\sigma(t) = i$ as long as $x(t) \in \Omega'_i$ and $\sigma(t^-) = i$;

(R₃) Once $x(t_1)$ hits the boundary of Ω'_i for some t_1 , let $t_0 = t_1$ and start over according to **(R₁)**.

Remark 5.4.1 The designed overlapping regions of Ω_i serve as “buffering regions” and produce hysteresis switching to avoid chattering. It would work well in this case since we have assumed that the nonlinearities g_i satisfy a linear growth condition, which happens to a standard requirement for the global existence of stochastic systems. As for switched

nonlinear systems studied in Section 2.5, this simple procedure of producing hysteresis switching does not necessarily avoid Zeno behavior because of the full nonlinearity as well as non-quadratic Lyapunov function considered there. \square

5.4.2 Stabilization of Systems with Linear Drifts

Theorem 5.4.1 *Let Assumption 5.4.1 hold and P, Q be defined by (5.4.3). Assume that there exist positive constants $\beta_j, 1 \leq j \leq 4$, such that*

$$\|\Delta A_i(t)\| \leq \beta_1, \quad \|\Delta B_i(t)\| \leq \beta_2, \quad (5.4.4)$$

and

$$|g_i(t, x, y)|^2 \leq \beta_3|x|^2 + \beta_4|y|^2, \quad (5.4.5)$$

for all $t \geq t_0, x \in \mathcal{R}^n, y \in \mathcal{R}^n$ and $i \in \{1, 2, \dots, N\}$. If for some $\zeta > 1$,

$$r < \frac{a^2 \sqrt{d^2 + acd}}{(d + \sqrt{d^2 + acd})(ac + d + \sqrt{d^2 + acd})},$$

where

$$a = \frac{1}{\zeta} \lambda_{\min}(Q) - \|P\| (2\beta_1 + 2\beta_2 + \beta_3 + \beta_4) > 0,$$

$$c = 2 \max_{1 \leq i \leq N} \|PB_i\| \left(\max_{1 \leq i \leq N} \|A_i\| + \max_{1 \leq i \leq N} \|B_i\| + \beta_1 + \beta_2 \right),$$

$$d = \max_{1 \leq i \leq N} \|PB_i\|^2 (\beta_3 + \beta_4),$$

then system (5.4.1) is exponentially stable in mean square.

Proof. Given any initial data ξ , we write $x(t; \xi)$ as $x(t)$ for simplicity. Let $v(t) = x^T(t)Px(t)$ for all $t \geq t_0 - r$. By Itô's formula, we have

$$\begin{aligned} dv(t) &= 2x^T(t)P[(A_i + \Delta A_i(t))x(t) + (B_i + \Delta B_i(t))x(t-r)]dt \\ &\quad + \text{trace}[g_i^T(t, x(t), x(t-r))Pg_i(t, x(t), x(t-r))]dt \\ &\quad + 2x^T(t)Pg_i(t, x(t), x(t-r))dW(t), \end{aligned} \quad (5.4.6)$$

where $x(t) \in \Omega'_i$ by how we have constructed $\sigma(t)$. By the definition of Ω'_i ,

$$x^T[(A_i + B_i)^T P + P(A_i + B_i)]x \leq -\frac{1}{\zeta}x^T Qx, \quad x \in \Omega'_i,$$

Using this and the assumptions, we can obtain the estimates

$$\begin{aligned} 2x^T(t)P[A_i x(t) + B_i x(t-r)] &= 2x^T(t)P[A_i + B_i]x(t) - 2x^T(t)PB_i[x(t) - x(t-r)] \\ &\leq -\frac{1}{\zeta}x^T(t)Qx(t) - 2x^T(t)PB_i[x(t) - x(t-r)] \\ &\leq -\frac{1}{\zeta}\lambda_{\min}(Q)|x(t)|^2 - 2x^T(t)PB_i[x(t) - x(t-r)], \end{aligned}$$

$$2x^T(t)P[\Delta A_i(t)x(t) + \Delta B_i(t)x(t-r)] \leq \|P\|((2\beta_1 + \beta_2)|x(t)|^2 + \beta_2|x(t-r)|^2),$$

and

$$\text{trace}[g_i^T(t, x(t), x(t-r))Pg_i(t, x(t), x(t-r))] \leq \|P\|(\beta_3|x(t)|^2 + \beta_4|x(t-r)|^2).$$

Substituting these into (5.4.6) gives

$$\begin{aligned} dv(t) &\leq -\left[\frac{1}{\zeta}\lambda_{\min}(Q) - \|P\|(2\beta_1 + \beta_2 + \beta_3)\right]|x(t)|^2 dt \\ &\quad + \|P\|(\beta_2 + \beta_4)|x(t-r)|^2 dt - 2x^T(t)PB_i[x(t) - x(t-r)]dt \\ &\quad + 2x^T(t)Pg_i(t, x(t), x(t-r))dW(t). \end{aligned} \tag{5.4.7}$$

Moreover, by the definition of stochastic integral, we have, for $t \geq h$,

$$\begin{aligned} x(t) - x(t-r) &= \int_{t-r}^t [(A_{\sigma(s)} + \Delta A_{\sigma(s)}(s))x(s) + (B_{\sigma(s)} + \Delta B_{\sigma(s)}(s))x(s-r)] ds \\ &\quad + \int_{t-r}^t g_{\sigma(s)}(s, x(s), x(s-r))dW(s). \end{aligned}$$

Note that regarding the switching signal as a function of time gives the simple expression above. Using this and the assumptions, we obtain, for $t \geq t_0 + r$,

$$\begin{aligned} &- 2x^T(t)PB_i[x(t) - x(t-r)] \\ &\leq [h(\gamma_1 + \gamma_2 + \gamma_3 + \gamma_4) + \gamma_5]|x(t)|^2 \\ &\quad + \max_{1 \leq i \leq N} \|PB_i\|^2 (\gamma_1^{-1} \max_{1 \leq i \leq N} \|A_i\|^2 + \gamma_3^{-1} \beta_1^2) \int_{t-r}^t |x(s)|^2 ds \\ &\quad + \max_{1 \leq i \leq N} \|PB_i\|^2 (\gamma_2^{-1} \max_{1 \leq i \leq N} \|B_i\|^2 + \gamma_4^{-1} \beta_2^2) \int_{t-r}^t |x(s-r)|^2 ds \\ &\quad + \gamma_5^{-1} \max_{1 \leq i \leq N} \|PB_i\|^2 \left| \int_{t-r}^t g_{\sigma(s)}(s, x(s), x(s-r))dW(s) \right|^2, \end{aligned}$$

where γ_i ($1 \leq i \leq 5$) can be chosen later to optimize the estimation. Substituting this into (5.4.7), we have two cases.

(i) For $t \geq t_0 + r$, we have

$$\begin{aligned} dv(t) \leq & \left[\kappa_1 |x(t)|^2 + \kappa_2 |x(t-r)|^2 + \kappa_3 \int_{t-r}^t |x(s)|^2 ds + \kappa_4 \int_{t-r}^t |x(s-r)|^2 ds \right] dt \\ & + \kappa_5 \left| \int_{t-r}^t g_{\sigma(s)}(s, x(s), x(s-r)) dW(s) \right|^2 dt \\ & + 2x^T(t)Pg_i(t, x(t), x(t-r))dW(t), \end{aligned} \quad (5.4.8)$$

where

$$\begin{aligned} \kappa_1 &= -\frac{1}{\zeta} \lambda_{\min}(Q) + \|P\| (2\beta_1 + \beta_2 + \beta_3) + r(\gamma_1 + \gamma_2 + \gamma_3 + \gamma_4) + \gamma_5, \\ \kappa_2 &= \|P\| (\beta_2 + \beta_4), \\ \kappa_3 &= \max_{1 \leq i \leq N} \|PB_i\|^2 (\gamma_1^{-1} \max_{1 \leq i \leq N} \|A_i\|^2 + \gamma_3^{-1} \beta_1^2), \\ \kappa_4 &= \max_{1 \leq i \leq N} \|PB_i\|^2 (\gamma_2^{-1} \max_{1 \leq i \leq N} \|B_i\|^2 + \gamma_4^{-1} \beta_2^2), \\ \kappa_5 &= \gamma_5^{-1} \max_{1 \leq i \leq N} \|PB_i\|^2. \end{aligned}$$

(ii) For $t_0 \leq t < t_0 + r$,

$$\begin{aligned} dv(t) \leq & - \left[\frac{1}{\zeta} \lambda_{\min}(Q) - \|P\| (2\beta_1 + \beta_2 + \beta_3) + 1 \right] |x(t)|^2 dt \\ & + \|P\| (\beta_2 + \beta_4) |x(t-r)|^2 dt + \max_{1 \leq i \leq N} \|PB_i\|^2 |x(t) - x(t-r)|^2 dt \\ & + 2x^T(t)Pg_i(t, x(t), x(t-r))dW(t). \end{aligned} \quad (5.4.9)$$

Now fix any $\varepsilon > 0$. It is clear that

$$d[e^{\varepsilon t} v(t)] = \varepsilon e^{\varepsilon t} x^T(t)Px(t)dt + e^{\varepsilon t} dv(t). \quad (5.4.10)$$

Moreover, by the Itô isometry, we have

$$\mathbb{E} \left\{ \left| \int_{t-r}^t g_{\sigma(s)}(s, x(s), x(s-r)) dW(s) \right|^2 \right\} = \int_{t-r}^t \mathbb{E} \left\{ |g_{\sigma(s)}(s, x(s), x(s-r))|^2 \right\} ds. \quad (5.4.11)$$

Substituting the previous estimates (5.4.8) and (5.4.9) for $dv(t)$ into (5.4.10), integrating from t_0 to t , taking expectation from both sides, and by virtue of (5.4.11), we can obtain

that, for all $t \geq t_0$ and $\varepsilon > 0$,

$$\begin{aligned}
\mathbb{E} \{ e^{\varepsilon t} v(t) \} &\leq \mathbb{E} \{ \xi(0) P \xi(0) \} + (\kappa_1 + \|P\| \varepsilon) \mathbb{E} \left\{ \int_{t_0+r}^t e^{\varepsilon s} |x(s)|^2 ds \right\} \\
&\quad + \kappa_2 \mathbb{E} \left\{ \int_{t_0+r}^t e^{\varepsilon s} |x(s-r)|^2 ds \right\} + \kappa_3 \int_{t_0+r}^t e^{\varepsilon s} \int_{s-r}^s \mathbb{E} \{ |x(\tau)|^2 \} d\tau ds \\
&\quad + \kappa_4 \int_{t_0+r}^t e^{\varepsilon s} \int_{s-r}^s \mathbb{E} \{ |x(\tau-r)|^2 \} d\tau ds \\
&\quad + \kappa_5 \int_{t_0+r}^t e^{\varepsilon s} \int_{s-r}^s \mathbb{E} \{ |g_{\sigma(\tau)}(\tau, x(\tau), x(\tau-r))|^2 \} d\tau ds + c_0 \\
&\leq \mathbb{E} \{ \xi(0) P \xi(0) \} + (\kappa_1 + \|P\| \varepsilon) \mathbb{E} \left\{ \int_{t-r}^t e^{\varepsilon s} |x(s)|^2 ds \right\} \\
&\quad + \kappa_2 \mathbb{E} \left\{ \int_{t_0+r}^t e^{\varepsilon s} |x(s-r)|^2 ds \right\} \\
&\quad + (\kappa_3 + \kappa_5 \beta_3) \int_{t_0+r}^t e^{\varepsilon s} \int_{s-r}^s \mathbb{E} \{ |x(\tau)|^2 \} d\tau ds \\
&\quad + (\kappa_4 + \kappa_5 \beta_4) \int_{t_0+r}^t e^{\varepsilon s} \int_{s-r}^s \mathbb{E} \{ |x(\tau-r)|^2 \} d\tau ds + c_0, \tag{5.4.12}
\end{aligned}$$

where

$$\begin{aligned}
c_0 &= -\left[\frac{1}{\zeta} \lambda_{\min}(Q) - \|P\| (2\beta_1 + \beta_2 + \beta_3 + \varepsilon) + 1 \right] \mathbb{E} \left\{ \int_{t_0}^r e^{\varepsilon s} |x(s)|^2 ds \right\} \\
&\quad + \kappa_2 \mathbb{E} \left\{ \int_{t_0}^r e^{\varepsilon s} |x(s-r)|^2 ds \right\} \\
&\quad + \max_{1 \leq i \leq N} \|PB_i\|^2 \mathbb{E} \left\{ \int_{t_0}^r e^{\varepsilon s} |x(s) - x(s-r)|^2 ds \right\} \\
&\leq -\left[\frac{1}{\zeta} \lambda_{\min}(Q) - \|P\| (2\beta_1 + \beta_2 + \beta_3 + \varepsilon) + 1 + \kappa_2 + 2 \max_{1 \leq i \leq N} \|PB_i\|^2 \right] \\
&\quad \times h e^{\varepsilon h} \mathbb{E} \{ \|\xi\| \} + 2 \max_{1 \leq i \leq N} \|PB_i\|^2 h e^{\varepsilon h} \mathbb{E} \{ \|x_{t_0+r}\| \} < \infty.
\end{aligned}$$

To get a simpler estimation of the right hand side, we compute the integrals in the previous inequality as follows. First, for $t \geq t_0 + r$,

$$\begin{aligned}
\mathbb{E} \left\{ \int_{t_0+r}^t e^{\varepsilon s} |x(s-r)|^2 ds \right\} &= \mathbb{E} \left\{ \int_{t_0}^{t-r} e^{\varepsilon(s+r)} |x(s)|^2 ds \right\} \\
&\leq e^{\varepsilon h} \mathbb{E} \left\{ \int_{t_0+r}^t e^{\varepsilon s} |x(s)|^2 ds \right\} + c_1,
\end{aligned}$$

where $c_1 = he^{2\epsilon h} \mathbb{E}\{\|\xi\|\} < \infty$. Moreover,

$$\begin{aligned} \int_{t_0+r}^t e^{\epsilon s} \int_{s-r}^s \mathbb{E}\{|x(r)|^2\} dr ds &\leq \int_{t_0}^t \mathbb{E}\{|x(r)|^2\} \int_{\tau}^{\tau+r} e^{\epsilon s} ds d\tau \\ &\leq he^{\epsilon h} \mathbb{E}\left\{ \int_{t_0+r}^t e^{\epsilon r} |x(r)|^2 dr \right\} + c_2, \end{aligned}$$

where $c_2 = hc_1 < \infty$. Finally,

$$\begin{aligned} \int_{t_0+r}^t e^{\epsilon s} \int_{s-r}^s \mathbb{E}\{|x(\tau-r)|^2\} d\tau ds &\leq he^{\epsilon h} \mathbb{E}\left\{ \int_{t_0}^t e^{\epsilon r} |x(\tau-r)|^2 d\tau \right\} \\ &\leq he^{2\epsilon h} \mathbb{E}\left\{ \int_{t_0+r}^t e^{\epsilon s} |x(s)|^2 ds \right\} + c_3, \end{aligned}$$

where $c_3 = c_1(h + re^{\epsilon h}) < \infty$. Substituting all these into (5.4.12) and reorganizing the items, we finally get

$$\mathbb{E}\left\{ e^{\epsilon t} x^T(t) P x(t) \right\} \leq \rho_1 + \rho_2 \mathbb{E}\left\{ \int_{t_0}^t e^{\epsilon s} |x(s)|^2 ds \right\}, \quad (5.4.13)$$

where

$$\rho_1 = \mathbb{E}\{\xi(0) P \xi(0)\} + \kappa_2 c_1 + (\kappa_3 + \kappa_5 \beta_3) c_2 + (\kappa_4 + \kappa_5 \beta_4) c_3 + c_0 < \infty,$$

and

$$\rho_2 = \kappa_1 + \|P\| \epsilon + \kappa_2 e^{\epsilon h} + (\kappa_3 + \kappa_5 \beta_3) h e^{\epsilon h} + (\kappa_4 + \kappa_5 \beta_4) h e^{2\epsilon h}.$$

Our aim is to find some positive ϵ such that $\rho_2 = 0$. Since ρ_2 is increasing with respect to ϵ , it is clear that if

$$\kappa_1 + \kappa_2 + (\kappa_3 + \kappa_5 \beta_3) h + (\kappa_4 + \kappa_5 \beta_4) r < 0,$$

then there exists some positive ϵ such that ρ_2 becomes 0. Recall what we denote by κ_i ($1 \leq i \leq 4$) and solve the previous inequality for h gives that

$$r < \frac{\frac{1}{\zeta} \lambda_{\min}(Q) - \|P\| (2\beta_1 + 2\beta_2 + \beta_3 + \beta_4) - \gamma_5}{D},$$

where

$$\begin{aligned} D &= (\gamma_1 + \gamma_2 + \gamma_3 + \gamma_4) + \max_{1 \leq i \leq N} \|PB_i\|^2 \times \\ &\quad (\gamma_1^{-1} \max_{1 \leq i \leq N} \|A_i\|^2 + \gamma_2^{-1} \max_{1 \leq i \leq N} \|B_i\|^2 + \gamma_3^{-1} \beta_1^2 + \gamma_4^{-1} \beta_2^2 + \gamma_5^{-1} \beta_3 + \gamma_5^{-1} \beta_4). \end{aligned}$$

Moreover, to relax the restriction on h , γ_i ($1 \leq i \leq 5$) can be chosen to minimize the denominator D , that is

$$\begin{aligned}\gamma_1 &= \max_{1 \leq i \leq N} \|PB_i\| \max_{1 \leq i \leq N} \|A_i\|, \\ \gamma_2 &= \max_{1 \leq i \leq N} \|PB_i\| \max_{1 \leq i \leq N} \|B_i\|, \\ \gamma_3 &= \max_{1 \leq i \leq N} \|PB_i\| \beta_1, \\ \gamma_4 &= \max_{1 \leq i \leq N} \|PB_i\| \beta_2,\end{aligned}$$

which immediately gives that

$$\begin{aligned}D &= 2 \max_{1 \leq i \leq N} \|PB_i\| \left(\max_{1 \leq i \leq N} \|A_i\| + \max_{1 \leq i \leq N} \|B_i\| + \beta_1 + \beta_2 \right) \\ &\quad + \gamma_5^{-1} \max_{1 \leq i \leq N} \|PB_i\|^2 (\beta_3 + \beta_4).\end{aligned}$$

Now, γ_5 is still not determined. To finish this, we observe that the function $f(x)$ on $(0, \infty)$ defined as

$$f(x) = \frac{a - x}{c + x^{-1}d}$$

for positive a , c , and d is increasing on $(0, \frac{ad}{d + \sqrt{d^2 + acd}})$ and decreasing on $(\frac{ad}{d + \sqrt{d^2 + acd}}, \infty)$.

Hence if we use the notations

$$\begin{aligned}a &= \frac{1}{\zeta} \lambda_{\min}(Q) - \|P\| (2\beta_1 + 2\beta_2 + \beta_3 + \beta_4), \\ c &= 2 \max_{1 \leq i \leq N} \|PB_i\| \left(\max_{1 \leq i \leq N} \|A_i\| + \max_{1 \leq i \leq N} \|B_i\| + \beta_1 + \beta_2 \right), \\ d &= \max_{1 \leq i \leq N} \|PB_i\|^2 (\beta_3 + \beta_4),\end{aligned}$$

then $\gamma_5 = \frac{ad}{d + \sqrt{d^2 + acd}}$ would maximize the upper bound of h and actually yields

$$r < \frac{a - \frac{ad}{d + \sqrt{d^2 + acd}}}{c + \frac{d + \sqrt{d^2 + acd}}{a}} = \frac{a^2 \sqrt{d^2 + acd}}{(d + \sqrt{d^2 + acd})(ac + d + \sqrt{d^2 + acd})},$$

which is our final restriction on h to guarantee that there exists some ε such that ρ_2 becomes 0. Hence we have, for this ε , that

$$\mathbb{E} \left\{ e^{\varepsilon t} x^T(t) P x(t) \right\} \leq \rho_1, \quad (5.4.14)$$

for $t \geq t_0 + r$, which eventually implies

$$\mathbb{E} \{ |x(t)|^2 \} \leq \frac{\rho_1 e^{-\varepsilon t}}{\lambda_{\min}(P)},$$

for all $t \geq t_0 + r$. Hence

$$\limsup_{t \rightarrow \infty} \frac{1}{t} \log \mathbb{E} \{ |x(t)|^2 \} \leq -\varepsilon,$$

which means system (5.4.1) is exponentially stable in mean square. \square

On the almost sure stability of system (5.4.1), we have the following theorem.

Theorem 5.4.2 *Under the same assumptions as in Theorem 5.4.1, system (5.4.1) is also almost surely exponentially stable.*

Proof. The proof is based on Doob's martingale inequality and the Borel-Cantelli lemma. For a complete proof one can refer to the proof of Theorem 5.5.4, where both impulses and switching are considered. \square

We consider two special cases of Theorems 5.4.1 and 5.4.2.

The case $g_i(t, x, y) \equiv 0$. If there is no stochastic perturbation in system (5.4.1), as corollaries of Theorems 5.4.1 and 5.4.2, we can have some results on deterministic switched systems. In this case, system (5.4.1) reduces to

$$\dot{x}(t) = (A_i + \Delta A_i(t))x(t) + (B_i + \Delta B_i(t))x(t - r), \quad \sigma(t) = i, \quad t \geq t_0. \quad (5.4.15)$$

For this system, we have the following corollary.

Corollary 5.4.1 *Let Assumption 5.4.1 hold and P, Q be defined as thereafter. Assume also there exist positive constants $\beta_j, 1 \leq j \leq 2$, such that*

$$\|\Delta A_i(t)\| \leq \beta_1, \quad \|\Delta B_i(t)\| \leq \beta_2, \quad (5.4.16)$$

for all $t \geq t_0$ and $i \in \{1, 2, \dots, N\}$. If for some $\zeta > 1$,

$$r < \frac{\lambda_{\min}(Q) - 2 \|P\| (\beta_1 + \beta_2)\zeta}{2\zeta \max_{1 \leq i \leq N} \|PB_i\| \left(\max_{1 \leq i \leq N} \|A_i\| + \max_{1 \leq i \leq N} \|B_i\| + \beta_1 + \beta_2 \right)},$$

then system (5.4.15) is exponentially stable in mean square and also almost surely exponentially stable.

The case $g_i(t, x, y) \equiv 0$ and $\Delta A_i(t) \equiv \Delta B_i(t) \equiv 0$. Now system (5.4.1) further reduces to

$$\dot{x}(t) = A_\sigma x(t) + B_\sigma x(t - r), \quad t \geq t_0. \quad (5.4.17)$$

which is actually the same system considered in [91]. For this system, we have the following corollary.

Corollary 5.4.2 *Let Assumption 5.4.1 hold and P, Q be defined as thereafter. If for some $\zeta > 1$,*

$$r < \frac{\lambda_{\min}(Q)}{2\zeta \max_{1 \leq i \leq N} \|PB_i\| \left(\max_{1 \leq i \leq N} \|A_i\| + \max_{1 \leq i \leq N} \|B_i\| \right)}, \quad (5.4.18)$$

then system (5.4.17) is exponentially stable in mean square and also almost surely exponentially stable.

5.4.3 Stabilization of Nonlinear Systems

Generally, we can consider the following nonlinear stochastic switched system

$$\begin{aligned} dx(t) = & [f_\sigma(t, x(t), x(t - r)) + \Delta f_\sigma(t, x(t), x(t - r))]dt \\ & + g_\sigma(t, x(t), x(t - r))dW(t), \quad t \geq t_0, \end{aligned} \quad (5.4.19)$$

$$x_{t_0} = \phi,$$

where $\sigma : [t_0, \infty) \rightarrow \{1, 2, \dots, N\}$ is the switching rule. We assume that f_i and Δf_i are locally Lipschitz continuous functions from $\mathcal{R}_+ \times \mathcal{R}^n \times \mathcal{R}^n \rightarrow \mathcal{R}^n$ satisfying the linear growth condition so that system (5.4.19) has a global unique solution. Moreover, suppose that $f_i(t, 0, 0) \equiv \Delta f_i(t, 0, 0) \equiv 0$ such that the system admits a trivial solution $x(t; 0) \equiv 0$.

The following assumption and lemma are the counterparts of Assumption 5.4.1 and Lemma 5.4.1.

Assumption 5.4.2 For system (5.4.19) defined above, there exist a symmetric positive definite matrix P and positive constants λ and $\alpha_i, 1 \leq i \leq N$, such that $\sum_{i=1}^N \alpha_i = 1$ and

$$2 \sum_{i=1}^N \alpha_i x^T P f_i(t, x, x) \leq -\lambda |x|^2,$$

for all $t \geq t_0$ and $x \in \mathcal{R}^n$. □

Lemma 5.4.2 *Define*

$$\Omega_i = \{x \in \mathcal{R}^n : x^T P f_i(t, x, x) + f_i^T(t, x, x) P x \leq -\lambda |x|^2\}.$$

Then $\mathcal{R}^n = \cup_{i=1}^N \Omega_i$.

This lemma essentially guarantees that we can construct a state-dependent switching rule for system (5.4.19) as we do in Section 5.4.2. Similar argument will lead to the following result.

Theorem 5.4.3 *Let Assumption 5.4.2 hold and P be the symmetric positive definite matrix. Assume also there exist positive constants δ_j , $1 \leq j \leq 3$, and β_k , $1 \leq k \leq 4$, such that*

$$|f_i(t, x, x) - f_i(t, x, y)| \leq \delta_1 |x - y|,$$

$$|f_i(t, x, y)| \leq \delta_2 |x| + \delta_3 |y|,$$

$$|\Delta f_i(t, x, y)| \leq \beta_1 |x| + \beta_2 |y|,$$

$$|g_i(t, x, y)|^2 \leq \beta_3 |x|^2 + \beta_4 |y|^2,$$

for all $t \geq t_0$, $x \in \mathcal{R}^n$, $y \in \mathcal{R}^n$, and $i \in \{1, 2, \dots, N\}$. If for some $\zeta > 1$,

$$r < \frac{a^2 \sqrt{d^2 + acd}}{(d + \sqrt{d^2 + acd})(ac + d + \sqrt{d^2 + acd})},$$

where

$$a = \frac{1}{\zeta} \lambda - \|P\| (2\beta_1 + 2\beta_2 + \beta_3 + \beta_4) > 0,$$

$$c = 2\delta_1 \|P\| (\delta_2 + \delta_3 + \beta_1 + \beta_2),$$

$$d = \delta_1 \|P\|^2 (\beta_3 + \beta_4),$$

then system (5.4.19) is exponentially stable in mean square and also almost surely exponentially stable.

Proof. The proof is essentially similar to the proof for Theorem 5.4.1 and is omitted. \square

If $g_i(t, x, y) \equiv 0$, then system (5.4.19) reduces to a deterministic switched system, i.e.,

$$\dot{x}(t) = f_\sigma(t, x(t), x(t-r)) + \Delta f_\sigma(t, x(t), x(t-r)), \quad t \geq t_0. \quad (5.4.20)$$

The following is a corollary of Theorem 5.4.2.

Corollary 5.4.3 *Let Assumption 5.4.2 hold and P be the symmetric positive definite matrix. Assume also there exist positive constants δ_j , $1 \leq j \leq 3$, and β_k , $1 \leq k \leq 2$, such that*

$$|f_i(t, x, x) - f_i(t, x, y)| \leq \delta_1 |x - y|,$$

$$|f_i(t, x, y)| \leq \delta_2 |x| + \delta_3 |y|,$$

$$|\Delta f_i(t, x, y)| \leq \beta_1 |x| + \beta_2 |y|,$$

for all $t \geq t_0$, $x \in \mathcal{R}^n$, $y \in \mathcal{R}^n$, and $i \in \{1, 2, \dots, N\}$. If for some $\zeta > 1$,

$$r < \frac{\lambda - 2 \|P\| (\beta_1 + \beta_2) \zeta}{2 \delta_1 \zeta \|P\| (\delta_2 + \delta_3 + \beta_1 + \beta_2)},$$

then system (5.4.20) is exponentially stable in mean square and also almost surely exponentially stable.

Furthermore, if $\Delta f_i(t, x, y) \equiv 0$, system (5.4.20) further reduces to

$$\dot{x}(t) = f_\sigma(t, x(t), x(t-r)), \quad t \geq t_0, \quad (5.4.21)$$

For this system, we have the following result.

Corollary 5.4.4 *Let Assumption 5.4.2 hold and P be the symmetric positive definite matrix. Assume also there exist positive constants δ_j , $1 \leq j \leq 3$, such that*

$$|f_i(t, x, x) - f_i(t, x, y)| \leq \delta_1 |x - y|,$$

$$|f_i(t, x, y)| \leq \delta_2 |x| + \delta_3 |y|,$$

for all $t \geq t_0$, $x \in \mathcal{R}^n$, $y \in \mathcal{R}^n$, and $i \in \{1, 2, \dots, N\}$. If for some $\zeta > 1$,

$$r < \frac{\lambda}{2 \delta_1 \zeta \|P\| (\delta_2 + \delta_3)},$$

then system (5.4.21) is exponentially stable in mean square and also almost surely exponentially stable.

5.4.4 Examples

Example 5.4.1 Consider a switched system with two subsystems given by

$$\begin{aligned} dx(t) = & \left[(A_1 + \Delta A_1(t))x(t) + (B_1 + \Delta B_1(t))x(t-r) \right] dt \\ & + g_1(t, x(t), x(t-r))dW(t), \end{aligned} \quad (5.4.22)$$

$$\begin{aligned} dx(t) = & \left[(A_2 + \Delta A_2(t))x(t) + (B_2 + \Delta B_2(t))x(t-r) \right] dt \\ & + g_2(t, x(t), x(t-h))dW(t), \end{aligned} \quad (5.4.23)$$

where

$$\begin{aligned} A_1 &= \begin{bmatrix} -2 & 2 \\ -20 & -2 \end{bmatrix}, & B_1 &= \begin{bmatrix} -1 & -7 \\ 23 & 6 \end{bmatrix}, \\ A_2 &= \begin{bmatrix} -2 & 10 \\ -4 & -2 \end{bmatrix}, & B_2 &= \begin{bmatrix} 4 & -5 \\ 1 & -8 \end{bmatrix}, \end{aligned}$$

$$\|\Delta A_i(t)\| \leq 0.1, \quad \|\Delta B_i(t)\| \leq 0.1, \quad i = 1, 2,$$

and

$$|g_i(t, x, y)|^2 \leq 0.1|x|^2 + 0.1|y|^2, \quad i = 1, 2,$$

for all $t \geq 0$ and $x = [x_1 \ x_2]^T$ and $y = [y_1 \ y_2]^T \in \mathcal{R}^2$. Let

$$H = 0.52(A_1 + B_1) + 0.48(A_2 + B_2)$$

and $Q = I_2$, we can find

$$P = \begin{bmatrix} 0.8247 & -0.0429 \\ -0.0429 & 0.1870 \end{bmatrix}$$

such that $PH + H^T P = -Q$. It is easy to compute that

$$\begin{aligned} \|P\| &= 0.8276, & \max_{1 \leq i \leq 2} \|PB_i\| &= 7.0148, \\ \max_{1 \leq i \leq 2} \|A_i\| &= 20.1803, & \max_{1 \leq i \leq 2} \|B_i\| &= 23.9390. \end{aligned}$$

Applying Theorem 5.4.1 with $\beta_1 = \beta_2 = \beta_3 = \beta_4 = 0.1$, we can conclude that the system switching between (5.4.22) and (5.4.23) via the switching rule σ is exponentially stable for $r < 5.6895 \times 10^{-4}$. If there are no stochastic perturbations and uncertainties,

i.e., $g_i(t, x, y) \equiv 0$ and $\Delta A_i(t) \equiv \Delta B_i(t) \equiv 0$, then the system reduces to Example 1 in [91]. Corollary 5.4.2 shows that the system is exponentially stable for $r < 0.001615$, which improves the delay upper bound of 0.001573 in [91]. Typical paths of the evolution and the switching rule σ for the above system are shown in Figures 5.2 and 5.3 for $r = 0.0005$, $\zeta = 1.1$,

$$\Delta A_1(t) = \Delta B_1(t) = 0.1 \sin(10t)I_2,$$

$$\Delta A_2(t) = \Delta B_2(t) = 0.1 \cos(10t)I_2,$$

and

$$g_1 = g_2 = \frac{\sqrt{0.1}}{2} \begin{bmatrix} x_1 \sin(x_1 y_1) + x_2 \sin(x_2 y_2) & 0 \\ 0 & y_1 \cos(x_1 y_1) + y_2 \cos(x_2 y_2) \end{bmatrix}.$$

Also, Figures 5.4 and 5.5 show that each subsystem is unstable even without uncertainties and stochastic perturbations. \square

Next we consider a switched system consisting of nonlinear subsystems.

Example 5.4.2 Consider a switched system with two subsystems given by

$$\begin{aligned} dx(t) &= [f_1(t, x(t), x(t-r)) + \Delta f_1(t, x(t), x(t-r))]dt \\ &\quad + g_1(t, x(t), x(t-r))dW(t), \end{aligned} \tag{5.4.24}$$

and

$$\begin{aligned} dx(t) &= [f_2(t, x(t), x(t-r)) + \Delta f_2(t, x(t), x(t-r))]dt \\ &\quad + g_2(t, x(t), x(t-r))dW(t), \end{aligned} \tag{5.4.25}$$

where

$$\begin{aligned} f_1(t, x, y) &= \left\{ \begin{array}{l} 0.5x_1 + 0.5y_1 - x_2 \sin(t) \\ x_1 \cos(t) - x_2 - y_2 \end{array} \right\}, \\ f_2(t, x, y) &= \left\{ \begin{array}{l} -x_1 - y_1 - x_2 \cos(t) \\ x_1 \sin(t) + 0.1x_2 + 0.9y_2 \end{array} \right\}, \end{aligned}$$

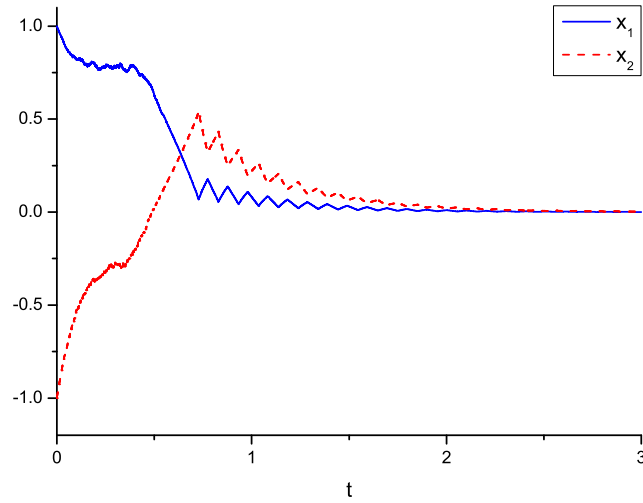

Figure 5.2 The solution of the system switching between (5.4.22) and (5.4.23) according to the switching signal $\sigma(t)$. The time-delay is set to be $h = 0.0016$ and the initial data given by $x = [1 \ -1]^T$.

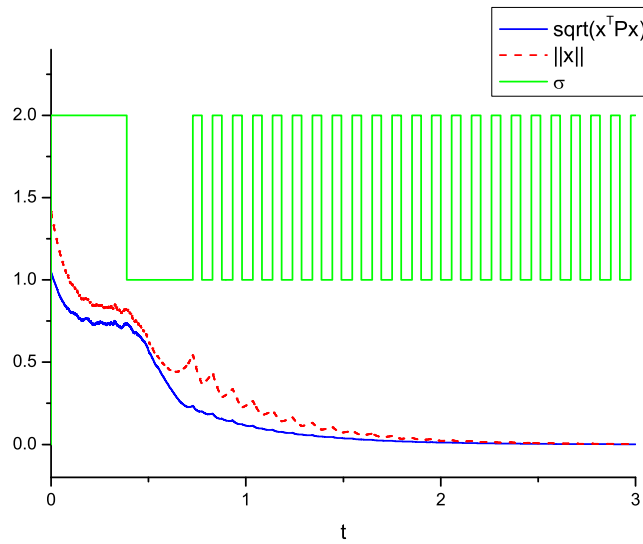

Figure 5.3 The Euclidian norm $|x|$ and quadratic norm $\sqrt{x^T P x}$ versus the constructed switching signal $\sigma(t)$.

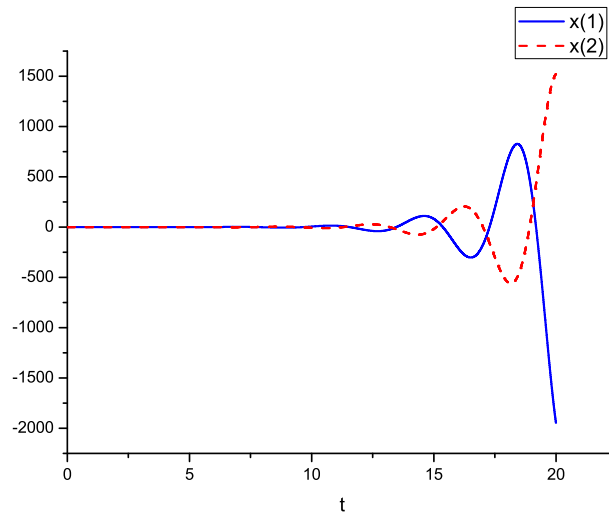

Figure 5.4 The solution of subsystem (5.4.22) without uncertainty and stochastic perturbation. The time-delay is set to be $r = 0.0005$ and the initial data given by $x = [0.01 \ 0.01]^T$.

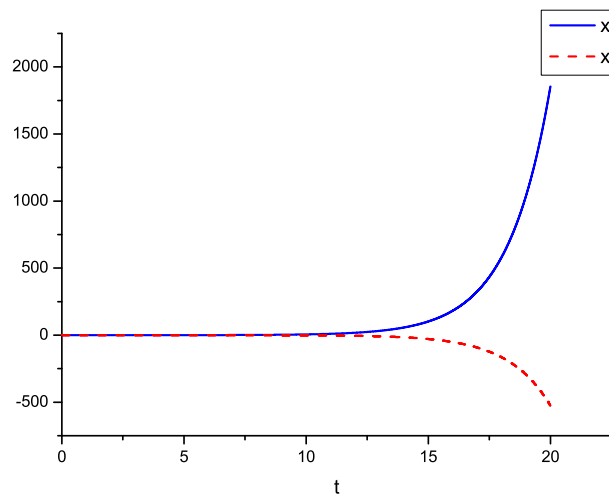

Figure 5.5 The solution of subsystem (5.4.23) without uncertainty and stochastic perturbation. The time-delay is set to be $r = 0.0005$ and the initial data given by $x = [0.01 \ 0.01]^T$.

for all $t \geq 0$ and $x, y \in \mathcal{R}^2$, and the uncertainties Δf_i and stochastic perturbations g_i are assumed to satisfy

$$\begin{aligned} |\Delta f_i(t, x, y)| &\leq 0.1|x| + 0.1|y|, \\ |g_i(t, x, y)|^2 &\leq 0.1|x|^2 + 0.1|y|^2, \end{aligned}$$

for $i = 1, 2, t \geq 0$, and $x, y \in \mathcal{R}^2$. It is easy to show that

$$\begin{aligned} 2\left[\frac{1}{2}x^T f_1(t, x, x) + \frac{1}{2}x^T f_2(t, x, x)\right] &\leq -|x|^2, \\ |f_i(t, x, x) - f_i(t, x, y)| &\leq |x - y|, \\ |f_i(t, x, y)| &\leq 2|x| + |y|, \end{aligned}$$

for $i = 1, 2, t \geq 0$, and $x, y \in \mathcal{R}^2$. To apply Theorem 5.4.2 with $\zeta = 1.1, \delta_1 = 1, \delta_2 = 2.24, \delta_3 = 1.74, \beta_1 = \beta_2 = \beta_3 = \beta_4 = 0.1, P = I_2$, and $\lambda = 1$, we can compute that

$$\begin{aligned} a &= \frac{1}{\zeta}\lambda - \|P\| (2\beta_1 + 2\beta_2 + \beta_3 + \beta_4) = 0.3091, \\ c &= 2\delta_1 \|P\| (\delta_2 + \delta_3 + \beta_1 + \beta_2) = 6.4, \\ d &= \delta_1 \|P\|^2 (\beta_3 + \beta_4) = 0.2. \end{aligned}$$

Thus Theorem 5.4.2 gives that, for

$$r < \frac{a^2 \sqrt{d^2 + acd}}{(d + \sqrt{d^2 + acd})(ac + d + \sqrt{d^2 + acd})} = 0.0258,$$

(25) is exponentially stable. Typical paths of the evolution and the switching rule σ for the above system are shown in Figures 5.6 and 5.7 for $h = 0.02, \zeta = 1.1$,

$$\Delta f_1 = \Delta f_2 = \begin{Bmatrix} 0.1x_1 \sin(y_1 y_2) + 0.1y_1 \cos(x_1 x_2) \\ 0.1x_2 \sin(y_1 y_2) + 0.1y_2 \cos(x_1 x_2) \end{Bmatrix},$$

and

$$g_1 = g_2 = \frac{\sqrt{0.1}}{2} \begin{bmatrix} x_1 \sin(x_1 y_1) + x_2 \sin(x_2 y_2) & 0 \\ 0 & y_1 \cos(x_1 y_1) + y_2 \cos(x_2 y_2) \end{bmatrix}.$$

Also, Figures 5.8 and 5.9 show that each subsystem is unstable even without uncertainties and stochastic perturbations. \square

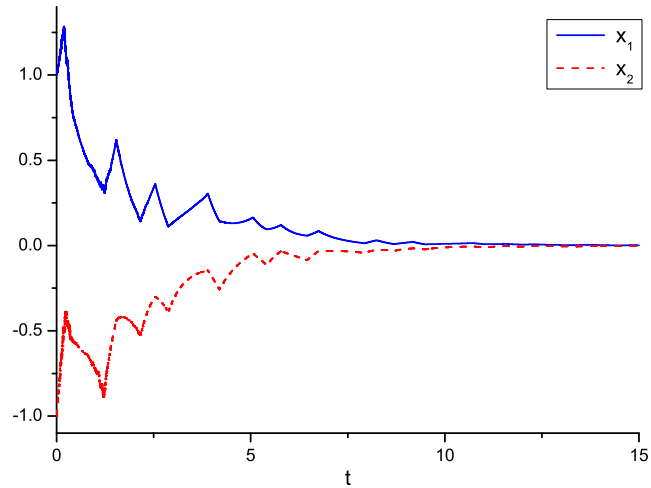

Figure 5.6 The solution of the system switching between (5.4.24) and (5.4.25) according to the switching signal $\sigma(t)$. The time-delay is set to be $h = 0.02$ and the initial data given by $x = [1 \ -1]^T$.

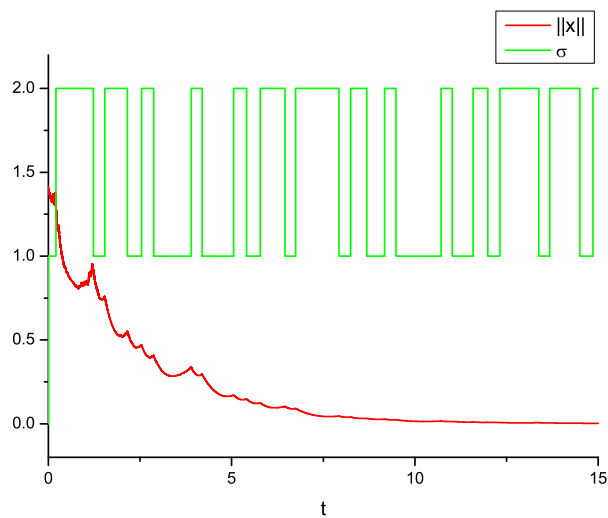

Figure 5.7 The Euclidian norm of x versus the constructed switching signal $\sigma(t)$. Note that in this case $P = I_2$ and the quadratic norm $\sqrt{x^T P x}$ coincides with the Euclidian norm.

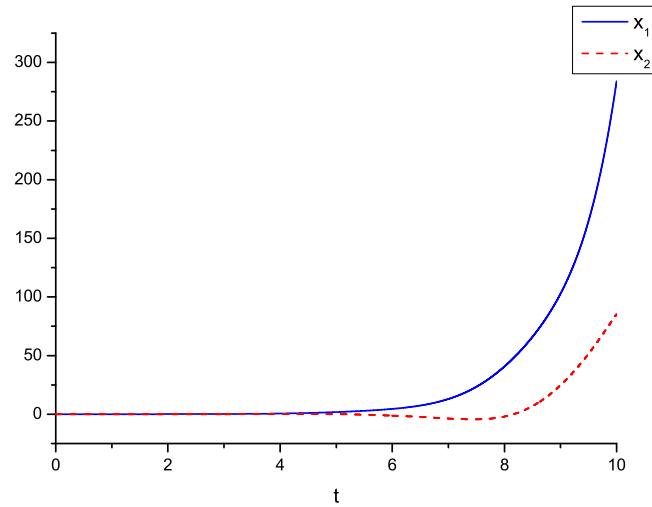

Figure 5.8 The solution of subsystem (5.4.24) without uncertainty and stochastic perturbation. The time-delay is set to be $r = 0.02$ and the initial data given by $x = [0.01 \ 0.01]^T$.

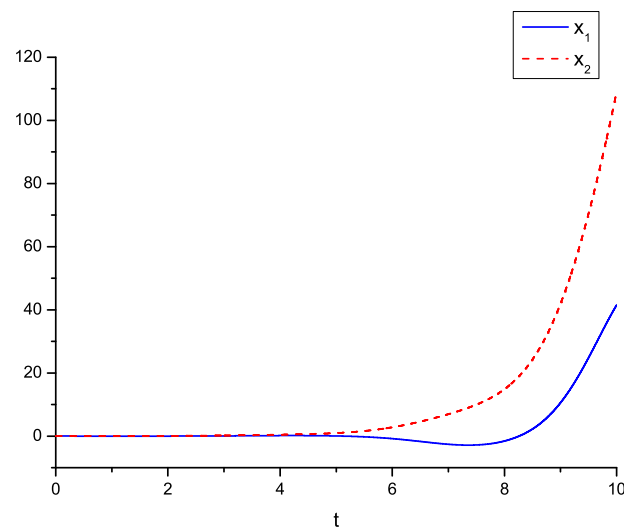

Figure 5.9 The solution of subsystem (5.4.25) without uncertainty and stochastic perturbation. The time-delay is set to be $r = 0.02$ and the initial data given by $x = [0.01 \ 0.01]^T$.

5.5 Razumikhin-Type Theorems for Stochastic Hybrid Delay Systems

In this section, we will apply multiple Lyapunov functions to obtain several Razumikhin-type results on the stability and stabilization of general stochastic hybrid systems with time-delay.

5.5.1 Preliminaries

We will focus on system (5.1.1) formulated in Section 5.1. Here it is assumed that $\{f_i : i \in \mathcal{I}\}$, $\{g_i : i \in \mathcal{I}\}$, and $\{I_j : j \in \mathcal{J}\}$ satisfy assumptions of Theorems 5.1.1 and 5.1.2 so that, for any initial data $\xi \in \mathcal{L}_{\mathcal{F}_{t_0}}^b$ and a given impulsive switching signal $\{(t_k, i_k, j_k)\}$, system (5.1.1) has a unique global solution, denoted by $x(t) = x(t; \xi)$, and, moreover, $x_t(\xi) \in \mathcal{L}_{\mathcal{F}_t}^p$ for all $t \geq t_0$ and $p > 0$. In addition, it is assumed that $f_i(t, 0) \equiv 0$, $g_i(t, 0) \equiv 0$, and $I_j(t, 0) = 0$, for all $i \in \mathcal{I}$, $j \in \mathcal{J}$ and $t \in \mathcal{R}^+$, so that system (5.1.1) admits a trivial solution.

Definitions of the two types of stability to be investigated, p th moment stability and almost sure stability, can be given in a similar way as Definition 5.3.1 in Section 5.3.

Definition 5.5.1 For $p > 0$, the trivial solution of system (5.1.1) is said to be **p th moment globally uniformly exponentially stable** (GUES) over a set \mathcal{S} of impulsive switching signals, if for any given initial data $\xi \in \mathcal{L}_{\mathcal{F}_{t_0}}^b$ and $\{(t_k, i_k, j_k)\} \in \mathcal{S}$, the solution $x(t; \xi)$ satisfies

$$\mathbb{E}\{|x(t; \xi)|^p\} \leq C \mathbb{E}\{\|\xi\|^p\} e^{-\varepsilon(t-t_0)}, \quad t \geq t_0, \quad (5.5.1)$$

where ε and C are positive constants independent of t_0 and the choice of $\{(t_k, i_k, j_k)\}$ in \mathcal{S} . It follows from (5.5.1) that

$$\limsup_{t \rightarrow \infty} \frac{1}{t} \log \mathbb{E}\{|x(t; \xi)|^p\} \leq -\varepsilon. \quad (5.5.2)$$

The left-hand side of (5.5.2) is called the **p th moment Lyapunov exponent** for the solution. Moreover, define

$$\limsup_{t \rightarrow \infty} \frac{1}{t} \log |x(t; \xi)| \quad (5.5.3)$$

to be the **Lyapunov exponent** of the solution. The trivial solution of system (5.1.1) is said to be **almost surely globally uniformly exponentially stable** if the Lyapunov exponent is bounded by a negative constant that is independent of the choice of $\xi \in \mathcal{L}_{\mathcal{F}_{t_0}}^b$ and $\{(t_k, i_k, j_k)\} \in \mathcal{S}$. \square

Remark 5.5.1 From Definition 5.5.1, one can see that the stability considered here is not only “uniform” with respect to the initial time, but also “uniform” with respect to an admissible set of impulsive switching signals \mathcal{S} , which in accordance with the uniform stability we have investigated in Section 2.4 for switched nonlinear systems and in [69] for switched linear systems. \square

The following definition formulates some particular classes of impulsive switching signals to be used in this section. The classification is based solely on the frequency of impulsive switching times.

5.5.2 Moment Exponential Stability: Average Dwell-Time Approach

In this subsection, the impulses are only considered as perturbations. Sufficient conditions for exponential stability are derived in terms of average dwell-time and Razumikhin-type conditions.

Theorem 5.5.1 *Let $p, c_1, c_2, \hat{d}, \lambda_i$, and $\rho_i \geq 1$ ($i \in \mathcal{I}$) be positive constants. Suppose that*

(i) *there exists a family of functions $\{V_i : i \in \mathcal{I}\} \subset \mathcal{C}^{1,2}$ such that*

$$c_1 |x|^p \leq V_i(t, x) \leq c_2 |x|^p, \quad (5.5.4)$$

for $(i, t, x) \in \mathcal{I} \times \mathcal{R}^+ \times \mathcal{R}^n$; and

(ii) *there exists a family of continuous functions $\{\mu_i : i \in \mathcal{I}\}$ from \mathcal{R}^+ to \mathcal{R} such that*

$$\mathbb{E}\{\mathcal{L}V_i(t, \phi)\} \leq \mu_i(t) \mathbb{E}\{V_i(t, \phi(0))\}, \quad (5.5.5)$$

whenever $i \in \mathcal{I}, t \geq t_0$, and $\phi \in \mathcal{L}_{\mathcal{F}_t}^p$ satisfies

$$\min_{i \in \mathcal{I}} \mathbb{E}\{V_i(t+s, \phi(s))\} \leq q \mathbb{E}\{V_i(t, \phi(0))\}, \quad \forall s \in [-r, 0], \quad (5.5.6)$$

where $q \geq e^{\mu r}$ is a finite constant and

$$\mu = \max_{i \in \mathcal{I}} \sup_{t \in [t_0, \infty)} \mu_i^-(t) < \infty, \quad (5.5.7)$$

where $\mu_i^- = \max(0, -\mu_i)$ is the negative part of the function μ_i .

Then the trivial solution of system (5.1.1) is p th moment globally uniformly exponentially stable on \mathcal{S} , where \mathcal{S} includes all impulsive switching signals $\sigma = \{(t_k, i_k, j_k)\}$ satisfying

(a) $\sigma \in \mathcal{S}_a^i(\tau_i, N_0)$ for each $i \in \mathcal{I}$,

(b) there exists a function $d : \mathcal{R}^+ \rightarrow [1, \infty)$ such that

$$\mathbb{E}\{V_{i_k}(t_k, \phi(0) + I_{j_k}(t_k, \phi))\} \leq \rho_{i_k} d(t_k) \mathbb{E}\{V_{i_{k-1}}(t, \phi(0))\}, \quad (5.5.8)$$

for $(t, \phi) \in \mathcal{R}^+ \times \mathcal{L}_{\mathcal{F}_t}^p$ and $i, j \in \mathcal{I}$,

(c) $\int_{t_0}^t [\mu_{\sigma(s)}(s) + \lambda_{\sigma(s)}] ds \leq 0$, for all $t \geq t_0$ (see²),

(d) $\prod_{k=1}^{\infty} d(t_k) \leq \hat{d}$, and

(e) $\tau_i > \ln(\rho_i)/\lambda_i$ for each $i \in \mathcal{I}$,

and its p th moment Lyapunov exponent is guaranteed to be not greater than $-\Lambda$, where $\Lambda = \min_{i \in \mathcal{I}} \{\lambda_i - \ln(\rho_i)/\tau_i\}$.

Proof. Let $\{(t_k, i_k, j_k)\}$ be a given signal \mathcal{S} , σ be as defined in condition (c), and $\xi \in \mathcal{L}_{\mathcal{F}_{t_0}}^b$ be the initial data, the global solution of (5.1.1) is simply denoted by $x(t)$. Without loss of generality, assume the initial data ξ is nontrivial so that $x(t)$ is not a trivial solution. Let $v(t) = \mathbb{E}\{V_{\sigma(t)}(t, x(t))\}$, for $t \geq t_0 - r$, and

$$u(t) = v(t) - \|v_{t_0}\| \prod_{i \in \mathcal{I}} \rho_i^{N_{\sigma}^i(t, t_0)} \prod_{t_0 < t_k \leq t} d(t_k) \exp\left\{\int_{t_0}^t \tilde{\mu}_{\sigma(s)}(s) ds\right\}, \quad t \geq t_0,$$

where $\|v_{t_0}\| = \max_{-r \leq s \leq 0} v(t_0 + s)$ and $\tilde{\mu}_i(t) = \mu_i(t) + \eta$, with $\eta > 0$ to be chosen later. Extend $u(t)$ to $[t_0 - r, t_0)$ by letting $u(t) = v(t) - \|v_{t_0}\|$ for $t \in [t_0 - r, t_0)$.

It is easy to see that $u(t)$ is continuous on $[t_0, t_1)$ and $u(t) \leq 0$ for $t \in [t_0 - r, t_0]$. We proceed to show that $u(t) \leq 0$ for $t \in [t_0, t_1)$. Assume this is not true. Then $u(t) \geq \alpha$ for some $t \in [t_0, t_1)$ and $\alpha > 0$. Let $t^* = \inf\{t \in [t_0, t_1) : u(t) > \alpha\}$. Since $u(t_0) \leq 0$, one must have $t^* \in (t_0, t_1)$ and $u(t^*) = \alpha$. Moreover, $u(t) \leq \alpha$ for $t \in [t_0 - r, t^*]$. Now for any

²Here σ is a switching signal reconstructed using the sequence of pairs $\{(t_k, i_k)\}$ by defining $\sigma(t) = i_k$ on $[t_k, t_{k+1})$. This was remarked in Remark 3.1.1 and should cause no confusion even we also use σ to denote the signal $\{(t_k, i_k, j_k)\}$ itself.

$s \in [-r, 0]$, one has

$$\begin{aligned} v(t^* + s) &\leq \alpha + \|v_{t_0}\| \exp\left(\int_{t_0}^{t^*+s} \tilde{\mu}_{\sigma(\theta)}(\theta) d\theta\right) \\ &\leq \max\left\{1, \exp\left(\int_{t^*}^{t^*+s} \tilde{\mu}_{\sigma(\theta)}(\theta) d\theta\right)\right\} v(t^*) \\ &\leq qv(t^*), \end{aligned}$$

since

$$\int_{t^*}^{t^*+s} \tilde{\mu}_{\sigma(\theta)}(\theta) d\theta \leq \int_{t^*}^{t^*+s} \mu_{\sigma(\theta)}(\theta) d\theta \leq \int_{t^*+s}^{t^*} \mu_{\sigma(\theta)}^-(\theta) d\theta \leq \mu r.$$

By (5.5.5) and (5.5.6), one has

$$\mathbb{E}\left\{\mathcal{L}V_{\sigma(t^*)}(t^*, x_{t^*})\right\} \leq \mu_{\sigma(t^*)}(t^*) \mathbb{E}\left\{V_{\sigma(t^*)}(t^*, x(t^*))\right\}.$$

Since $u(t^*) = \alpha > 0$, it is clear that $\mathbb{E}\left\{V_{\sigma(t^*)}(t^*, x(t^*))\right\} = v(t^*) > 0$. Hence

$$\begin{aligned} &\mathbb{E}\left\{\mathcal{L}V_{\sigma(t^*)}(t^*, x_{t^*})\right\} - \tilde{\mu}_{\sigma(t^*)}(t^*) \mathbb{E}\left\{V_{\sigma(t^*)}(t^*, x(t^*))\right\} \\ &< \mathbb{E}\left\{\mathcal{L}V_{\sigma(t^*)}(t^*, x_{t^*})\right\} - \mu_{\sigma(t^*)}(t^*) \mathbb{E}\left\{V_{\sigma(t^*)}(t^*, x(t^*))\right\} \\ &\leq 0, \end{aligned}$$

which, by continuity, implies that

$$\mathbb{E}\left\{\mathcal{L}V_{\sigma(\theta)}(\theta, x_\theta)\right\} - \tilde{\mu}_{\sigma(\theta)}(\theta) \mathbb{E}\left\{V_{\sigma(\theta)}(\theta, x(\theta))\right\} \leq 0, \quad \theta \in [t^*, t^* + h],$$

provided that h is sufficiently small. Applying Itô's formula on $[t^*, t^* + h']$, where $h' \in [0, h]$, one has

$$\begin{aligned} u(t^* + h') - u(t^*) &= \int_{t^*}^{t^*+h'} \left[\mathbb{E}\left\{\mathcal{L}V_{\sigma(\theta)}(\theta, x_\theta)\right\} - \tilde{\mu}_{\sigma(\theta)}(\theta) \mathbb{E}\left\{V_{\sigma(\theta)}(\theta, x(\theta))\right\} \right] d\theta \\ &\leq 0, \end{aligned}$$

for all $h' \in [0, h]$, which contradicts the definition of t^* . Therefore, one must have $u(t) \leq 0$ for $t \in [t_0, t_1)$.

Now assume that $u(t) \leq 0$, $\forall t \in [t_0 - r, t_m)$, where $m \geq 1$ is a positive integer. We proceed to show that $u(t) \leq 0$ on $[t_m, t_{m+1})$. To derive a contradiction, assume that $u(t) \leq 0$ does not hold on $[t_m, t_{m+1})$. Then $u(t) \geq \alpha$ for some $t \in [t_m, t_{m+1})$ and some $\alpha > 0$. Let

$t^* = \inf\{t \in [t_m, t_{m+1}) : u(t) > \alpha\}$. Since, by (5.5.8),

$$\begin{aligned} u(t_m) &= v(t_m) - \|v_{t_0}\| \prod_{i \in \mathcal{I}} \rho_i^{N_\sigma^i(t_m, t_0)} \prod_{t_0 < t_k \leq t_m} d(t_k) \exp\left(\int_{t_0}^{t_m} \tilde{\mu}_{\sigma(\theta)}(\theta) d\theta\right) \\ &\leq \rho_{\sigma(t_m)} d(t_m) \left\{ v(t_m^-) - \|v_{t_0}\| \prod_{i \in \mathcal{I}} \rho_i^{N_\sigma^i(t_m^-, t_0)} \prod_{t_0 < t_k < t_m} d(t_k) \exp\left(\int_{t_0}^{t_m} \tilde{\mu}_{\sigma(\theta)}(\theta) d\theta\right) \right\} \\ &\leq 0, \end{aligned}$$

one must have $t^* \in (t_m, t_{m+1})$ and $u(t^*) = \alpha$. Moreover, $u(t) \leq \alpha$ for $t \in [t_0 - r, t^*]$. For $s \in [-r, 0]$, one now has,

$$\begin{aligned} v(t^* + s) &\leq \alpha + \|v_{t_0}\| \prod_{i \in \mathcal{I}} \rho_i^{N_\sigma^i(t^* + s, t_0)} \prod_{t_0 < t_k \leq t^* + s} d(t_k) \exp\left(\int_{t_0}^{t^* + s} \tilde{\mu}_{\sigma(\theta)}(\theta) d\theta\right) \\ &\leq \max\left\{1, \exp\left(\int_{t^*}^{t^* + s} \tilde{\mu}_{\sigma(\theta)}(\theta) d\theta\right)\right\} v(t^*) \\ &\leq qv(t^*). \end{aligned}$$

Repeating the same argument as on $[t_0, t_1)$, one can derive a contradiction and hence show that $u(t) \leq 0$ for $t \in [t_m, t_{m+1})$. By induction on m , one can conclude that $u(t) \leq 0$ for all $t \geq t_0$, which implies

$$v(t) \leq \hat{d} \|v_{t_0}\| \prod_{i \in \mathcal{I}} \rho_i^{N_\sigma^i(t, t_0)} \exp\left(\int_{t_0}^t \tilde{\mu}_{\sigma(s)}(s) ds\right), \quad \forall t \geq t_0. \quad (5.5.9)$$

Since $\eta > 0$ is arbitrary and independent of t , (5.5.9) actually implies

$$v(t) \leq \hat{d} \|v_{t_0}\| \prod_{i \in \mathcal{I}} \rho_i^{N_\sigma^i(t, t_0)} \exp\left(\int_{t_0}^t \mu_{\sigma(s)}(s) ds\right), \quad \forall t \geq t_0. \quad (5.5.10)$$

By (5.5.4) and the fact that $\sigma \in \mathcal{S}$, (5.5.10) gives

$$\begin{aligned} \mathbb{E}\{|x(t)|^p\} &\leq C \mathbb{E}\{\|\xi\|^p\} \exp\left\{\sum_{i \in \mathcal{I}} \int_{[t_0, t] \cap \sigma^{-1}(\{i\})} \frac{\ln(\rho_i)}{\tau_i} ds - \int_{t_0}^t \lambda_{\sigma(s)} ds\right\} \\ &\leq C \mathbb{E}\{\|\xi\|^p\} \exp\left\{-\int_{t_0}^t \left[\lambda_{\sigma(s)} - \frac{\ln(\rho_{\sigma(s)})}{\tau_{\sigma(s)}}\right] ds\right\} \\ &\leq C \mathbb{E}\{\|\xi\|^p\} e^{-\Lambda(t-t_0)}, \end{aligned}$$

where $C = \hat{d} \prod_{i \in \mathcal{I}} \rho_i^{N_0} c_2/c_1$, which shows that the p th moment of system (5.1.1) is GUES with its p th moment Lyapunov exponent not greater than $-\Lambda$. \square

Remark 5.5.2 The formulation of the set \mathcal{S} of impulsive switching signals in Theorem 5.5.1 essentially proposes an average dwell-time condition $\tau_i > \ln(\rho_i)/\lambda_i$ for each individual mode, which generalizes the well-known average dwell-time notion from [68]. Moreover, it allows the existence of unstable mode since $\mu_i(t)$ can be positive on certain subintervals of \mathcal{R}^+ . The condition to guarantee stability is then given by the integral relation in condition (c) of the theorem, which essentially says that the switching between the stable modes and unstable modes results in a “stable” balance such that

$$\int_{t_0}^t [\mu_{\sigma(s)}(s) + \lambda_{\sigma(s)}] ds \leq 0.$$

This relation bears the same idea which we have used to investigate uniform stability of switched nonlinear systems with both stable and unstable modes in Chapter 2 (see also, [199] for switched linear systems; [1] and [200] for switched delay systems with linear structures), but now in a more general way. \square

Remark 5.5.3 According to Theorem 5.5.1, the average dwell-time condition for the i th mode is given by $\tau_i > \ln(\rho_i)/\lambda_i$. If $\rho_i = 1$, this condition reduces to $\tau_i > 0$, which would read as the i th mode has a positive average dwell-time condition. A closer scrutiny of the proof (see the estimate (5.5.10)) reveals that there is essentially no average dwell-time restriction on the i th mode, if (5.5.8) is satisfied with $\rho_i = 1$. \square

5.5.3 Moment Exponential Stability: Impulsive Stabilization

In this subsection, assuming that all the subsystems are unstable, impulses are added as a stabilizing mechanism to exponentially stabilize system (5.1.1).

Theorem 5.5.2 Let $\Lambda, p, c_1, c_2, \rho_i < 1, \delta_i (i \in \mathcal{I}), \hat{d}$ be positive constants and $\bar{v}_i (i \in \mathcal{I})$ be nonnegative numbers. Suppose that

(i) condition (i) of Theorem 5.5.1 holds; and

(ii) there exists a family of continuous functions $\{v_i : i \in \mathcal{I}\}$ from $[t_0, \infty)$ to \mathcal{R}^+ satisfying

$$\sup_{t \in [t_0, \infty)} \int_t^{t+\delta_i} v_i(s) \leq \bar{v}_i \delta_i, \quad (5.5.11)$$

such that

$$\mathbb{E}\{\mathcal{L}V_i(t, \phi)\} \leq v_i(t) \mathbb{E}\{V_i(t, \phi(0))\}, \quad (5.5.12)$$

whenever $i \in \mathcal{I}$, $t \geq t_0$, and $\phi \in \mathcal{L}_{\mathcal{F}_t}^p$ satisfies

$$\min_{i \in \mathcal{I}} \mathbf{E} \{V_i(t+s, \phi(s))\} \leq q_i \mathbf{E} \{V_i(t, \phi(0))\}, \quad \forall s \in [-r, 0], \quad (5.5.13)$$

where $q_i \geq 1$ is a constant such that

$$q_i \geq \exp(\Lambda r + \Lambda \delta_i + \bar{v}_i \delta_i). \quad (5.5.14)$$

Then the trivial solution of system (5.1.1) is p th moment globally uniformly exponentially stable on \mathcal{S} , where \mathcal{S} includes all impulsive switching signals $\sigma = \{(t_k, i_k, j_k)\}$ satisfying

- (a) $\sigma \in \mathcal{S}_{\text{sup}}^i(\delta_i)$ for all $i \in \mathcal{I}$,
- (b) same as (b) in Theorem 5.5.1,
- (c) $\prod_{k=1}^{\infty} d(t_k) \leq \hat{d}$,
- (d) $\delta_i < -\ln(\rho_i)/(\Lambda + \bar{v}_i)$, for all $i \in \mathcal{I}$,

and its p th moment Lyapunov exponent is not greater than $-\Lambda$.

Proof. Keep the same notation as in the proof for Theorem 5.5.1. Let $\tilde{\Lambda} = \Lambda - \eta$, where $\eta > 0$ being an arbitrary number such that $\tilde{\Lambda} > 0$. Choose $M \in (e^{(\Lambda + \bar{v}_{i_0})\delta_{i_0}}, q_{i_0} e^{\Lambda \delta_{i_0}})$ so that

$$\|v_{t_0}\| < M \|v_{t_0}\| e^{-(\Lambda + \bar{v}_{i_0})\delta_{i_0}} < M \|v_{t_0}\| e^{-\Lambda \delta_{i_0}} < q_{i_0} \|v_{t_0}\|, \quad (5.5.15)$$

where $i_0 = \sigma(t_0)$ and $\|v_{t_0}\| = \max_{-r \leq s \leq 0} v(t_0 + s)$. We will show that

$$v(t) \leq M \mathbf{E}\{\|\xi\|^p\} e^{-\tilde{\Lambda}(t-t_0)}, \quad \forall t \in [t_0, t_1], \quad (5.5.16)$$

by proving a stronger claim:

$$v(t) \leq M \|v_{t_0}\| e^{-\Lambda \delta_{i_0}}, \quad \forall t \in [t_0, t_1]. \quad (5.5.17)$$

Suppose (5.5.17) is not true and observe that

$$v(t) \leq \|v_{t_0}\| < M \|v_{t_0}\| e^{-\Lambda \delta_{i_0}}, \quad (5.5.18)$$

holds on $[t_0 - r, t_0]$. Define $t^* = \inf\{t \in [t_0, t_1] : v(t) > M \|v_{t_0}\| e^{-\Lambda \delta_{i_0}}\}$. Then $t^* \in (t_0, t_1)$ and, by continuity of $v(t)$,

$$v(t) \leq v(t^*) = M \|v_{t_0}\| e^{-\Lambda \delta_{i_0}}, \quad \forall t \in [t_0, t^*]. \quad (5.5.19)$$

In view of (5.5.18), define $t_* = \sup\{t \in [t_0, t^*] : v(t) \leq \|v_{t_0}\|\}$. Then $t_* \in [t_0, t^*]$ and, by continuity of $v(t)$,

$$v(t) \geq v(t_*) = \|v_{t_0}\|, \quad \forall t \in [t_*, t^*]. \quad (5.5.20)$$

Now in view of (5.5.15), (5.5.19), and (5.5.20), one has, for $t \in [t_*, t^*]$ and $s \in [-r, 0]$,

$$v(t+s) \leq v(t^*) = M\|v_{t_0}\|e^{-\Lambda\delta_{i_0}} < q_{i_0}\|v_{t_0}\| \leq q_{i_0}v(t).$$

By the Razumikhin-type conditions (5.5.12) and (5.5.13), one has

$$\mathbb{E}\{\mathcal{L}V_{\sigma(t)}(t, x_t)\} \leq v_{\sigma(t)}(t) \mathbb{E}\{V_{\sigma(t, x(t))}\}, \quad \forall t \in [t_*, t^*]. \quad (5.5.21)$$

Applying Itô's formula on $[t_*, t^*]$ and by (5.5.21), one obtains that

$$\begin{aligned} & e^{\int_{t_0}^{t^*} v_{\sigma(s)}(s)ds} v(t^*) - e^{\int_{t_0}^{t_*} v_{\sigma(s)}(s)ds} v(t_*) \\ &= \int_{t_*}^{t^*} e^{\int_{t_0}^s v_{\sigma(s)}(s)ds} [\mathbb{E}\{\mathcal{L}V_{\sigma(s)}(s, x_s)\} - v_{\sigma(s)}(s) \mathbb{E}\{V_{\sigma(s)}(s, x(s))\}] ds \\ &\leq 0, \end{aligned}$$

which implies, by (5.5.11),

$$v(t^*) \leq v(t_*) e^{\int_{t_*}^{t^*} v_{\sigma(s)}(s)ds} \leq v(t_*) e^{\bar{v}_{i_0}\delta_{i_0}}. \quad (5.5.22)$$

Since (5.5.22) contradicts what is implied by (5.5.15), (5.5.19), and (5.5.20), claim (5.5.17) must be true and so is (5.5.16). Although the choice of M in (5.5.15) depends on i_0 , one can choose some M independent of i_0 such that (5.5.16) holds, due to the fact that \mathcal{I} is a finite set.

Now, assume that

$$v(t) \leq M_k \|v_{t_0}\| e^{-\tilde{\Lambda}(t_k - t_0)}, \quad \forall t \in [t_{k-1}, t_k], \quad (5.5.23)$$

for all $k \leq m$, where $k, m \in \mathbb{Z}^+$ and M_k is defined by $M_1 = M$ and $M_k = M_{k-1}d(t_{k-1})$, for $k \geq 2$. We proceed to show that

$$v(t) \leq M_{m+1} \|v_{t_0}\| e^{-\tilde{\Lambda}(t_{m+1} - t_0)}, \quad \forall t \in [t_m, t_{m+1}], \quad (5.5.24)$$

by proving a stronger claim:

$$v(t) \leq M_{m+1} \|v_{t_0}\| e^{-\tilde{\Lambda}[(t_m - t_0) + \delta_{i_m}]}, \quad \forall t \in [t_m, t_{m+1}], \quad (5.5.25)$$

where $i_m = \sigma(t_m)$. From (5.5.23) and (5.5.8), one has

$$v(t_m) \leq \rho_{i_m} d(t_m) v(t_m^-) \leq \rho_{i_m} d(t_m) M_m \|v_{t_0}\| e^{-\tilde{\Lambda}(t_m-t_0)} = \rho_{i_m} M_{m+1} \|v_{t_0}\| e^{-\tilde{\Lambda}(t_m-t_0)},$$

which implies, by the fact that $\sigma \in \mathcal{S}$,

$$v(t_m) < e^{-\bar{v}_{i_m} \delta_{i_m}} M_{m+1} \|v_{t_0}\| e^{-\tilde{\Lambda}[(t_m-t_0)+\delta_{i_m}]}. \quad (5.5.26)$$

Choose $\varepsilon > 0$ sufficiently small such that

$$\begin{aligned} v(t_m) &< e^{-\bar{v}_{i_m} \delta_{i_m} - \varepsilon} M_{m+1} \|v_{t_0}\| e^{-\tilde{\Lambda}[(t_m-t_0)+\delta_{i_m}]} \\ &< e^{-\bar{v}_{i_m} \delta_{i_m}} M_{m+1} \|v_{t_0}\| e^{-\tilde{\Lambda}[(t_m-t_0)+\delta_{i_m}]}. \end{aligned} \quad (5.5.27)$$

Suppose claim (5.5.25) is not true. Define

$$\bar{t} = \inf \left\{ t \in [t_m, t_{m+1}) : v(t) > M_{m+1} \|v_{t_0}\| e^{-\tilde{\Lambda}[(t_m-t_0)+\delta_{i_m}]} \right\}.$$

In view of (5.5.26), one has $\bar{t} \in (t_m, t_{m+1})$ and, by continuity of $v(t)$,

$$v(t) \leq v(\bar{t}) = M_{m+1} \|v_{t_0}\| e^{-\tilde{\Lambda}[(t_m-t_0)+\delta_{i_m}]}, \quad \forall t \in [t_m, \bar{t}]. \quad (5.5.28)$$

In view of (5.5.27), define

$$\underline{t} = \sup \left\{ t \in [t_m, \bar{t}) : v(t) \leq e^{-\bar{v}_{i_m} \delta_{i_m} - \varepsilon} M_{m+1} \|v_{t_0}\| e^{-\tilde{\Lambda}[(t_m-t_0)+\delta_{i_m}]} \right\}.$$

Then $\underline{t} \in (t_m, \bar{t})$ and, by continuity of $v(t)$,

$$v(t) \geq v(\underline{t}) = e^{-\bar{v}_{i_m} \delta_{i_m} - \varepsilon} M_{m+1} \|v_{t_0}\| e^{-\tilde{\Lambda}[(t_m-t_0)+\delta_{i_m}]} = e^{-\bar{v}_{i_m} \delta_{i_m} - \varepsilon} v(\bar{t}), \quad (5.5.29)$$

for all $t \in [\underline{t}, \bar{t}]$. Now for $t \in [\underline{t}, \bar{t}]$ and $s \in [-r, 0]$, from (5.5.14), (5.5.23), (5.5.29), and the fact that $t + s \in [t_{m-1}, \bar{t}]$, one has

$$\begin{aligned} v(t+s) &\leq M_{m+1} \|v_{t_0}\| e^{-\tilde{\Lambda}(t+s-t_0)} = e^{\tilde{\Lambda}(t_m-t) - \tilde{\Lambda}s + \tilde{\Lambda}\delta_{i_m}} v(\bar{t}) \\ &\leq e^{\tilde{\Lambda}r + \tilde{\Lambda}\delta_{i_m} + \bar{v}_{i_m}\delta_{i_m} + \varepsilon} v(\underline{t}) \\ &\leq q_{i_m} v(t), \end{aligned}$$

provided that ε defined in (5.5.27) is chosen sufficiently small. Similar to the argument on $[t_*, t^*]$, an application of Itô's formula on $[\underline{t}, \bar{t}]$ will lead to $v(\bar{t}) \leq v(\underline{t}) e^{\bar{v}_{i_m} \delta_{i_m}}$, which would contradict (5.5.29). Therefore, claim (5.5.25) must be true and so is (5.5.24). By induction on m and the definition of M_m , one can conclude that

$$v(t) \leq M \prod_{t_0 < t_k \leq t} d(t_k) \|v_{t_0}\| e^{-\tilde{\Lambda}(t-t_0)}, \quad \forall t \geq t_0.$$

By (5.5.4) and the condition on $d(t)$, one has

$$\mathbb{E} \{ |x(t)|^p \} \leq M \hat{d} \frac{c_2}{c_1} \mathbb{E} \{ \|\xi\|^p \} e^{-\tilde{\Lambda}(t-t_0)}, \quad \forall t \geq t_0.$$

Since $\eta > 0$ is arbitrary and independent of t , we actually have shown

$$\mathbb{E} \{ |x(t)|^p \} \leq M \hat{d} \frac{c_2}{c_1} \mathbb{E} \{ \|\xi\|^p \} e^{-\Lambda(t-t_0)}, \quad \forall t \geq t_0,$$

which shows that the p th moment of system (5.1.1) is GUES with its p th moment Lyapunov exponent not greater than $-\Lambda$. \square

5.5.4 Moment Exponential Stability: Combined Hybrid Strategy

Theorems 5.5.1 and 5.5.2 address the average dwell-time approach and impulsive stabilization, respectively. While Theorem 5.5.1 applies to the situation when both stable and unstable modes are present in the switched system and stability is achieved by restricting the switching signal so that a certain balance between the activation time of the stable mode and the unstable mode, Theorem 5.5.2 assumes all the modes are unstable and addresses how one can seek an impulsive stabilization rule for a certain class of switching signals. In this section, these two approaches are combined to achieve a stabilization result for impulsive switched stochastic delay systems.

The motivation for proposing this strategy is the fact that impulse stabilization should be kept to a minimal in many applications due to its cost. We consider applying impulses only when the system is about to switch to an unstable mode. Otherwise, the requirement for stability is guaranteed by imposing an average dwell-time condition. For this purpose, we propose a partition of the subsystems by $\mathcal{I} = \mathcal{I}_s \cup \mathcal{I}_u$ and $\mathcal{I}_s \cap \mathcal{I}_u = \emptyset$. Recall the notion from Section 3.1.1 and define

$$[t, T]_\sigma^s = \bigcup_{i \in \mathcal{I}_s} [t, T]_\sigma^i, \quad [t, T]_\sigma^u = \bigcup_{i \in \mathcal{I}_u} [t, T]_\sigma^i,$$

i.e., $[t, T]_\sigma^s$ and $[t, T]_\sigma^u$ denote the union of all subintervals of $[t, T]$ on which a mode in \mathcal{I}_s and \mathcal{I}_u , respectively, is activated.

The combined hybrid strategy can be described as follows:

- (i) on $[t, T]_\sigma^s$, stabilization is achieved by an average dwell-time approach and impulsive stabilization is not performed; and
- (ii) on $[t, T]_\sigma^u$, a stabilizing impulse is added at each impulsive switching time.

Theorem 5.5.3 Let $\lambda, \Lambda, p, c_1, c_2, \hat{d}, \rho_i \geq 1$ ($i \in \mathcal{I}_s$), $\tau_i, \delta_i, \rho_i < 1$ be positive constants and \bar{v}_i ($i \in \mathcal{I}_u$) be nonnegative constants. Suppose that

- (i) condition (i) of Theorem 5.5.1 holds;
- (ii) there exists a family of continuous functions $\{\mu_i : i \in \mathcal{I}_s\}$ from $[t_0, \infty)$ to \mathcal{R} such that condition (ii) of Theorem 5.5.1 holds, for all $i \in \mathcal{I}_s$, with

$$\mu = \max_{i \in \mathcal{I}_s} \sup_{t \in [t_0, \infty)} \mu_i^-(t); \quad (5.5.30)$$

- (iii) there exists a family of continuous functions $\{v_i : i \in \mathcal{I}_u\}$ from $[t_0, \infty)$ to \mathcal{R}^+ satisfying (5.5.11) such that condition (ii) of Theorem 5.5.2 is satisfied, for all $i \in \mathcal{I}_u$, with

$$q_i \geq \exp(\mu r + \Lambda \delta_i + \bar{v}_i \delta_i). \quad (5.5.31)$$

Then the trivial solution of system (7.1.1) is p th moment globally uniformly exponentially stable on \mathcal{S} , where \mathcal{S} includes all impulsive switching signals $\sigma = \{(t_k, i_k, j_k)\}$ satisfying

(a) $\sigma \in \mathcal{S}_a^i(\tau_i, N_0)$ for all $i \in \mathcal{I}_s$ and $\sigma \in \mathcal{S}_{\text{sup}}^i(\delta_i)$ for all $i \in \mathcal{I}_u$,

(b) same as (b) in Theorem 5.5.1,

(c) $\prod_{k=1}^{\infty} d(t_k) \leq \hat{d}$,

(d) $\int_{[t_0, t]_{\sigma}^s} [\mu_{\sigma(s)}(s) + \lambda_{\sigma(s)}] ds \leq 0$, for all $t \geq t_0$,

(e) $\tau_i > \ln(\rho_i)/\lambda_i$, for all $i \in \mathcal{I}_s$,

(f) $\delta_i < -\ln(\rho_i)/(\Lambda + \bar{v}_i)$, for all $i \in \mathcal{I}_u$,

where $\Lambda = \min_{i \in \mathcal{I}_s} \{\lambda_i - \ln(\rho_i)/\tau_i\}$, and its p th moment Lyapunov exponent is not greater than $-\Lambda$.

Proof. Keep the same notation as in the proof for Theorem 5.5.1. The proof is essentially a combination of the proofs for Theorems 5.5.1 and 5.5.2. Let $\eta \in (0, \Lambda)$ be an arbitrary number and define

$$\tilde{\Lambda} = \Lambda - \eta, \quad \tilde{\mu}_i(t) = \mu_i(t) + \eta, \quad t \geq t_0, \quad i \in \mathcal{I}_s.$$

We claim that, for all $t \geq t_0$,

$$v(t) \leq M \|v_{t_0}\| \prod_{i \in \mathcal{I}_s} \rho_i^{N_\sigma^i(t, t_0)} \prod_{t_0 < t_k \leq t} d(t_k) \exp \left(\int_{[t_0, t]_\sigma^s} \tilde{\mu}_\sigma(s) ds - \int_{[t_0, t_\sigma]_\sigma^s} \tilde{\Lambda} ds \right),$$

where $\|v_{t_0}\| = \max_{-r \leq s \leq 0} v(t_0 + s)$, $M > 1$ is as chosen in the proof of Theorem 5.5.2, and t_σ is the next switching instant of σ beyond t . For simplicity, let $u(t)$ denote the right-hand side of the claimed inequality. We shall prove the claim by induction on $[t_{k-1}, t_k)$, $k \in \mathcal{Z}^+$. Starting on $[t_0, t_1)$, consider two cases: (i) $i_0 = \sigma(t_0) \in \mathcal{I}_s$, (ii) $i_0 \in \mathcal{I}_u$. We have

(i) following the argument in the proof of Theorem 5.5.1,

$$v(t) \leq \|v_{t_0}\| e^{\int_{t_0}^t \tilde{\mu}_\sigma(s) ds}, \quad t \in [t_0, t_1),$$

which implies the claim on $[t_0, t_1)$,

(ii) following the argument in the proof for Theorem 5.5.2,

$$v(t) \leq M \|v_{t_0}\| e^{-\tilde{\Lambda} \delta_{i_0}}, \quad \forall t \in [t_0, t_1),$$

which also implies the claim on $[t_0, t_1)$.

Now suppose that the claim is true on $[t_0, t_m)$, where $m \in \mathcal{Z}^+$. We shall show that it is also true on $[t_m, t_{m+1})$. Consider the following three cases:

(a) $\sigma(t_m) \in \mathcal{I}_s$. Suppose that the claim is not true on $[t_m, t_{m+1})$. Then there exists some $\alpha > 0$ such that $v(t) \leq u(t) + \alpha$, for some $t \in [t_m, t_{m+1})$. Let $t^* = \inf\{t \in [t_m, t_{m+1}) : v(t) > u(t) + \alpha\}$. Since $v(t_m) \leq u(t_m)$, one must have $t^* \in (t_m, t_{m+1})$. Moreover, by continuity of v and u on $[t_m, t_m + 1)$, $v(t^*) = u(t^*) + \alpha$ and $v(t) \leq u(t) + \alpha$ for $t \in [t_0 - r, t^*]$. Now for any $s \in [-r, 0]$, one has

$$v(t^* + s) \leq u(t^* + s) + \alpha \leq \max \left\{ 1, \frac{u(t^* + s)}{u(t^*)} \right\} v(t^*),$$

where

$$\begin{aligned} \frac{u(t^* + s)}{u(t^*)} &= \exp \left(\int_{[t^*, t^* + s]_\sigma^s} \tilde{\mu}_\sigma(s) ds - \int_{[t_\sigma^*, (t^* + s)_\sigma]_\sigma^u} \tilde{\Lambda} ds \right) \\ &\leq \exp \left(\int_{[t^*, t^* + s]_\sigma^s} \tilde{\mu}_\sigma(s) ds - \int_{[t^*, (t^* + s)_\sigma]_\sigma^u} \tilde{\Lambda} ds \right) \\ &\leq \exp \left(\int_{[t^* + s, t^*]_\sigma^s} \mu ds + \int_{[t^* + s, t^*]_\sigma^u} \Lambda ds \right) \\ &\leq \exp(\mu r), \end{aligned}$$

where in the last inequality the fact that $\Lambda \leq \mu$ (implied by the theorem conditions) is used. Following the same argument as in the proof of Theorem 5.5.1, one can draw a contradiction by applying Itô's formula and the Razumikhin-type argument. Therefore, we have shown that the claim holds on $[t_m, t_{m+1})$.

(b) $\sigma(t_m) \in \mathcal{I}_u$. On $[t_m - r, t_m)$, one has, by the inductive assumption,

$$v(t) \leq u(t) \leq C_m e^{\mu r}, \quad (5.5.32)$$

where

$$C_m = M \|v_{t_0}\| \prod_{i \in \mathcal{I}_s} \rho_i^{N_\sigma^i(t_m, t_0)} \prod_{1 \leq k \leq m} d(t_k) \exp \left(\int_{[t_0, t_m]_\sigma^s} \tilde{\mu}_\sigma(s) ds - \int_{[t_0, t_m]_\sigma^u} \tilde{\Lambda} ds \right),$$

and

$$v(t_m) < C_m e^{-\bar{v}_{i_m} \delta_{i_m} - \tilde{\Lambda} \delta_{i_m} - \varepsilon} < C_m e^{-\bar{v}_{i_m} \delta_{i_m} - \tilde{\Lambda} \delta_{i_m}},$$

where $i_m = \sigma(t_m)$ and $\varepsilon > 0$ is a sufficiently small number.

We shall show that

$$v(t) \leq C_m e^{-\tilde{\Lambda} \delta_{i_m}}, \quad \forall t \in [t_m, t_{m+1}). \quad (5.5.33)$$

Assume (5.5.33) is not true. Define

$$\bar{t} = \inf \left\{ t \in [t_m, t_{m+1}) : v(t) > C_m e^{-\tilde{\Lambda} \delta_{i_m}} \right\}.$$

and

$$\underline{t} = \sup \left\{ t \in [t_m, \bar{t}) : v(t) \leq C_m e^{-\bar{v}_{i_m} \delta_{i_m} - \tilde{\Lambda} \delta_{i_m} - \varepsilon} \right\}.$$

Then

$$v(\underline{t}) = C_m e^{-\bar{v}_{i_m} \delta_{i_m} - \tilde{\Lambda} \delta_{i_m} - \varepsilon} = e^{-\bar{v}_{i_m} \delta_{i_m} - \varepsilon} v(\bar{t}), \quad (5.5.34)$$

and

$$v(t) \leq v(\bar{t}), \quad \forall t \in [t_m, \bar{t}], \quad (5.5.35)$$

$$v(t) \geq v(\underline{t}), \quad \forall t \in [\underline{t}, \bar{t}]. \quad (5.5.36)$$

Therefore, for $t \in [\underline{t}, \bar{t}]$ and $s \in [-r, 0]$, from (5.5.32), (5.5.35), and (5.5.36), one can obtain

$$v(t+s) \leq C_m e^{\mu r} \leq e^{\mu r + \bar{v}_{i_m} \delta_{i_m} + \tilde{\Lambda} \delta_{i_m} + \varepsilon} v(\underline{t}) \leq q_{i_m} v(t),$$

provided that $\varepsilon > 0$ has been chosen sufficiently small.

By the Razumikhin-type conditions (iii) and applying Itô's formula on $[\underline{t}, \bar{t}]$, one can show that

$$v(\bar{t}) \leq v(\underline{t}) e^{\bar{v}_{im} \delta_{im}},$$

which would contradict (5.5.34). Therefore (5.5.33) must be true. It follows immediately that the claim holds on $[t_m, t_{m+1})$.

We can now conclude that the claim holds for all $t \geq t_0$. By the arbitrary choice of η , we actually have

$$v(t) \leq M \|v_{t_0}\| \prod_{i \in \mathcal{I}_s} \rho_i^{N_\sigma^i(t, t_0)} \prod_{t_0 < t_k \leq t} d(t_k) \exp \left(\int_{[t_0, t]_\sigma^s} \mu_{\sigma(s)}(s) ds - \int_{[t_0, t_\sigma]_\sigma^u} \Lambda ds \right),$$

which, by the fact that $\sigma \in \mathcal{S}$, implies

$$\begin{aligned} v(t) &\leq M \hat{d} \|v_{t_0}\| \prod_{i \in \mathcal{I}_s} \rho_i^{N_0} \exp \left(\int_{[t_0, t]_\sigma^s} \left[\frac{\ln(\rho_{\sigma(s)})}{\tau_{\sigma(s)}} - \lambda_{\sigma(s)} \right] ds - \int_{[t_0, t_\sigma]_\sigma^u} \Lambda ds \right) \\ &= M \hat{d} \|v_{t_0}\| \prod_{i \in \mathcal{I}_s} \rho_i^{N_0} e^{-\Lambda(t-t_0)}. \end{aligned}$$

Finally, by (5.5.4), we have

$$\mathbb{E} \{ |x(t)|^p \} \leq C \mathbb{E} \{ \|\xi\|^p \} e^{-\Lambda(t-t_0)}, \quad \forall t \geq t_0,$$

with $C = M \hat{d} \prod_{i \in \mathcal{I}_s} \rho_i^{N_0} c_2/c_1$, which shows the p th moment of system (7.1.1) is GUES with its p th moment Lyapunov exponent not greater than $-\Lambda$. \square

5.5.5 Almost Sure Exponential Stability

In this section, with some additional conditions, we show that the trivial solution of system (7.1.1) is also almost surely exponential stable, provided that the conditions in Theorems 5.5.1, 5.5.2, or 5.5.3 are satisfied.

Theorem 5.5.4 *Let $p \geq 1$, $C > 0$ and $\Lambda > 0$. Suppose there exists a constant $K > 0$ such that*

$$\mathbb{E} \{ |f_i(t, \phi)|^p \vee |g_i(t, \phi)|^p \vee |l_j(t, \phi)|^p \} \leq K \sup_{-r \leq s \leq 0} \mathbb{E} \{ |\phi(s)|^p \}, \quad (5.5.37)$$

for all $i \in \mathcal{I}$, $j \in \mathcal{J}$, and $(t, \phi) \in \mathcal{L}_{\mathcal{F}_t}^p$. Moreover, suppose $\sigma \in \mathcal{S}_a(\tau, N_0)$. Then

$$\mathbb{E} \{ |x(t; \xi)|^p \} \leq C \mathbb{E} \{ \|\xi\|^p \} e^{-\Lambda(t-t_0)}, \quad t \geq t_0, \quad (5.5.38)$$

implies

$$\limsup_{t \rightarrow \infty} \frac{1}{t} \log |x(t; \xi)| \leq -\frac{\Lambda}{p}, \quad a.s. \quad (5.5.39)$$

where $x(t; \xi)$ is a given solution to system (7.1.1).

Proof. Write $x(t) = x(t; \xi)$ in the following. Let $s_m = t_0 + mr$, where $m \geq 1$ is a positive integer. Consider system (7.1.1) on $[s_{m-1}, s_m]$ for $m \geq 2$. We have

$$x(t) = x(s_{m-1}) + \int_{s_{m-1}}^{s_m} f_{\sigma(s)}(s, x_s) ds + \int_{s_{m-1}}^{s_m} g_{\sigma(s)}(s, x_s) dW(s) + \Sigma_m, \quad (5.5.40)$$

where

$$\Sigma_m = \sum_{t_k \in (s_{m-1}, s_m]} I_{jk}(t_k, x_{t_k}^-).$$

By Hölder's inequality, (5.5.40) implies

$$\begin{aligned} \mathbb{E} \{ \|x_{s_m}\|^p \} &\leq 4^{p-1} \left[\mathbb{E} \{ |x(s_{m-1})|^p \} + \mathbb{E} \left\{ \int_{s_{m-1}}^{s_m} |f_{\sigma(s)}(s, x_s)| ds \right\}^p \right. \\ &\quad \left. + \mathbb{E} \left\{ \sup_{0 \leq h \leq r} \left| \int_{s_{m-1}}^{s_{m-1}+h} g_{\sigma(s)}(s, x_s) dW(s) \right|^p \right\} + \mathbb{E} \{ |\Sigma_m|^p \} \right]. \end{aligned} \quad (5.5.41)$$

Now, according to (5.5.37) and (5.5.38) and using Hölder's inequality,

$$\begin{aligned} \mathbb{E} \left\{ \int_{s_{m-1}}^{s_m} |f_{\sigma(s)}(s, x_s)| ds \right\}^p &\leq Kr^{p-1} \int_{s_{m-1}}^{s_m} \sup_{-r \leq \theta \leq 0} \mathbb{E} \{ |x(s+\theta)|^p \} ds \\ &\leq Kr^{p-1} C \mathbb{E} \{ \|\xi\|^p \} \int_{s_{m-1}}^{s_m} e^{-\Lambda(s-r-t_0)} ds \\ &\leq Kr^p C \mathbb{E} \{ \|\xi\|^p \} e^{-\Lambda(m-2)r}. \end{aligned} \quad (5.5.42)$$

By the Burkholder-Davis-Gundy inequality (see, e.g., [140, p.40, Theorem 7.3]),

$$\mathbb{E} \left\{ \sup_{0 \leq h \leq r} \left| \int_{s_{m-1}}^{s_{m-1}+h} g_{\sigma(s)}(s, x_s) dW(s) \right|^p \right\} \leq C_p \mathbb{E} \left\{ \int_{s_{m-1}}^{s_m} |g_{\sigma(s)}(s, x_s)|^2 ds \right\}^{\frac{p}{2}}, \quad (5.5.43)$$

where C_p is a constant that depends only on p . Note that (5.5.37) actually implies $|g_i(t, \phi)|^p \leq K \|\phi\|^p$, for all $(i, t, \phi) \in \mathcal{I} \times \mathcal{R}^+ \times \mathcal{PC}$. Hence we can show that

$$\begin{aligned}
& \mathbb{E} \left\{ \int_{s_{m-1}}^{s_m} |g_{\sigma(s)}(s, x_s)|^2 ds \right\}^{\frac{p}{2}} \\
& \leq \mathbb{E} \left\{ \sup_{s_{m-1} \leq s \leq s_m} |g_{\sigma(s)}(s, x_s)| \int_{s_{m-1}}^{s_m} |g_{\sigma(s)}(s, x_s)| ds \right\}^{\frac{p}{2}} \\
& \leq \kappa \mathbb{E} \left\{ \sup_{s_{m-1} \leq s \leq s_m} |g_{\sigma(s)}(s, x_s)|^p \right\} + \kappa^{-1} \mathbb{E} \left\{ \int_{s_{m-1}}^{s_m} |g_{\sigma(s)}(s, x_s)| ds \right\}^p \\
& \leq \kappa K \mathbb{E} \left\{ \sup_{s_{m-1} \leq s \leq s_m} \|x_s\|^p \right\} + \kappa^{-1} r^{p-1} \int_{s_{m-1}}^{s_m} \mathbb{E} \left\{ |g_{\sigma(s)}(s, x_s)|^p \right\} ds \\
& \leq \kappa K \mathbb{E} \left\{ \|x_{s_m}\|^p \right\} + \kappa K \mathbb{E} \left\{ \|x_{s_{m-1}}\|^p \right\} + \kappa^{-1} K r^p C \mathbb{E} \left\{ \|\xi\|^p \right\} e^{-\Lambda(m-2)r}, \quad (5.5.44)
\end{aligned}$$

where $\kappa > 0$ is to be chosen later. Since $\sigma \in \mathcal{S}_a(\tau, N_0)$, there are at most $N = \lfloor r/\tau + N_0 \rfloor$ terms in Σ_m and hence

$$\begin{aligned}
\mathbb{E} \left\{ |\Sigma_m|^p \right\} & \leq N^{p-1} \sum_{t_k \in (s_{m-1}, s_m]} |I_{j_k}(t_k, x_{t_k^-})|^p \\
& \leq N^{p-1} K \sum_{t_k \in (s_{m-1}, s_m]} \sup_{-r \leq s < 0} \mathbb{E} \left\{ |x(t_k + s)|^p \right\} \\
& \leq N^p K C \mathbb{E} \left\{ \|\xi\|^p \right\} e^{-\Lambda(m-2)r}. \quad (5.5.45)
\end{aligned}$$

Combining (5.5.41)–(5.5.45) gives

$$\mathbb{E} \left\{ \|x_{s_m}\|^p \right\} \leq 4^{p-1} \kappa K C_p \left[\mathbb{E} \left\{ \|x_{s_m}\|^p \right\} + \mathbb{E} \left\{ \|x_{s_{m-1}}\|^p \right\} \right] + L e^{-\Lambda(m-2)r}, \quad (5.5.46)$$

where $L = [(C_p \kappa^{-1} r^p + N^p) K C + 1] \mathbb{E} \left\{ \|\xi\|^p \right\}$, a quantity independent of k . Now choose $\kappa > 0$ sufficiently small such that

$$0 < \frac{4^{p-1} \kappa K C_p}{1 - 4^{p-1} \kappa K C_p} < e^{-\Lambda r}.$$

Then (5.5.46) implies

$$\mathbb{E} \left\{ \|x_{s_m}\|^p \right\} \leq e^{-\Lambda r} \mathbb{E} \left\{ \|x_{s_{m-1}}\|^p \right\} + L e^{-\Lambda(m-2)r},$$

which is valid for all $m \geq 2$ and hence, by induction, implies

$$\begin{aligned}
\mathbb{E} \left\{ \|x_{s_m}\|^p \right\} & \leq e^{-\Lambda(m-1)r} \mathbb{E} \left\{ \|x_{s_1}\|^p \right\} + (m-1) L e^{-\Lambda(m-2)r}, \\
& \leq \left[\mathbb{E} \left\{ \|x_{s_1}\|^p \right\} + e^{\Lambda r} \right] m L e^{-\Lambda(m-1)r}, \quad \forall m \geq 2. \quad (5.5.47)
\end{aligned}$$

Define, for $m \geq 2$,

$$A_m := \{\omega : \|x_{s_m}\|^p > e^{-(\Lambda-\varepsilon)(m-1)r}\},$$

where $\varepsilon \in (0, \Lambda)$ is arbitrary. By (5.5.47),

$$P(A_m) \leq e^{(\Lambda-\varepsilon)(m-1)r} \mathbb{E}\{\|x_{s_m}\|^p\} \leq [\mathbb{E}\{\|x_{s_1}\|^p\} + e^{\Lambda r}] m L e^{-\varepsilon(m-1)r}.$$

The Borel-Cantelli lemma implies that $P(\limsup_{m \rightarrow \infty} A_m) = 0$, i.e., for almost all $\omega \in \Omega$, there exists an $M(\omega)$ such that

$$\|x_{s_m}\|^p \leq e^{-(\Lambda-\varepsilon)(m-1)r}, \quad \forall m \geq M(\omega), \quad (5.5.48)$$

which implies that, for $t \in [s_{m-1}, s_m]$,

$$\frac{1}{t} \log |x(t)|^p \leq -\frac{(\Lambda - \varepsilon)(m - 1)r}{t_0 + mr}, \quad \forall m \geq M(\omega).$$

Therefore, for almost all $\omega \in \Omega$,

$$\limsup_{t \rightarrow \infty} \frac{1}{t} \log(|x(t)|) \leq \lim_{m \rightarrow \infty} -\frac{(\Lambda - \varepsilon)(m - 1)r}{(t_0 + mr)p} = -\frac{\Lambda - \varepsilon}{p}. \quad (5.5.49)$$

Since $\varepsilon \in (0, \Lambda)$ is arbitrary, (5.5.39) follows from (5.5.49). The proof is complete. \square

Corollary 5.5.1 *If $p \geq 1$, then the same conditions as in Theorems 5.5.1 and 5.5.2 together with the conditions in Theorem 5.5.4 imply (5.5.39), i.e., the trivial solution of system (7.1.1) is also almost surely exponentially stable with its Lyapunov exponent not greater than $-\Lambda/p$.*

If $0 < p < 1$, a slightly stronger assumption on the coefficients f_i and g_i is needed while the assumption on I remains the same.

Theorem 5.5.5 *Let $0 < p < 1$ and suppose there exists a constant $K > 0$ such that the solution process x_t satisfies*

$$\mathbb{E} \left\{ \sup_{-r \leq s \leq 0} [|f_i(t+s, x_{t+s})|^p \vee |g_i(t+s, x_{t+s})|^p] \right\} \leq K \sup_{-2r \leq s \leq 0} \mathbb{E} \{ |x(s)|^p \}, \quad (5.5.50)$$

for all $i \in \mathcal{I}$ and $t \geq t_0 + r$ and

$$\mathbb{E} \{ |I_j(t, \phi)|^p \} \leq K \sup_{-r \leq s \leq 0} \mathbb{E} \{ |\phi(s)|^p \}, \quad (5.5.51)$$

for all $i \in \mathcal{I}, j \in \mathcal{J}$, and $(t, \phi) \in \mathcal{L}_{\mathcal{F}_t}^p$. Suppose, in addition, $\sigma \in \mathcal{S}_a(\tau, N_0)$. Then (5.5.38) implies (5.5.39).

Proof. From (5.5.40), we have

$$\begin{aligned} \mathbb{E} \{ \|x_{s_m}\|^p \} &\leq \left[\mathbb{E} \{ |x(s_{m-1})|^p \} + \mathbb{E} \left\{ \int_{s_{m-1}}^{s_m} |f_{\sigma(s)}(s, x_s)| ds \right\}^p \right. \\ &\quad \left. + \mathbb{E} \left\{ \sup_{0 \leq h \leq r} \left| \int_{s_{m-1}}^{s_{m-1}+h} g_{\sigma(s)}(s, x_s) dW(s) \right|^p \right\} + \mathbb{E} \{ |\Sigma_m|^p \} \right], \end{aligned} \quad (5.5.52)$$

where the fact that $(\sum a_i)^p \leq \sum a_i^p$, for nonnegative reals a_i and $0 < p < 1$, is used. According to (5.5.38) and (5.5.50),

$$\begin{aligned} \mathbb{E} \left\{ \int_{s_{m-1}}^{s_m} |f_{\sigma(s)}(s, x_s)| ds \right\}^p &\leq r^p \mathbb{E} \left\{ \sup_{s_{m-1} \leq s \leq s_m} |f_{\sigma(s)}(s, x_s)|^p \right\} \\ &\leq Kr^p \sup_{s_{m-2} \leq s \leq s_m} \mathbb{E} \{ |x(s)|^p \} \\ &\leq Kr^p C \mathbb{E} \{ \|\xi\|^p \} e^{-\Lambda(m-2)r}. \end{aligned} \quad (5.5.53)$$

While (5.5.43) remains valid, (5.5.50) implies

$$\begin{aligned} \mathbb{E} \left\{ \int_{s_{m-1}}^{s_m} |g_{\sigma(s)}(s, x_s)|^2 ds \right\}^{\frac{p}{2}} &\leq r^{\frac{p}{2}} \mathbb{E} \left\{ \sup_{s_{m-1} \leq s \leq s_m} |g_{\sigma(s)}(s, x_s)|^p \right\} \\ &\leq Kr^{\frac{p}{2}} C \mathbb{E} \{ \|\xi\|^p \} e^{-\Lambda(m-2)r}. \end{aligned} \quad (5.5.54)$$

On the other hand, according to (5.5.51),

$$\begin{aligned} \mathbb{E} \{ |\Sigma_m|^p \} &\leq \sum_{t_k \in (s_{m-1}, s_m]} \mathbb{E} \left\{ |I_{j_k}(t_k, x_{t_k}^-)|^p \right\} \\ &\leq K \sum_{t_k \in (s_{m-1}, s_m]} \sup_{-r \leq s < 0} \mathbb{E} \{ |x(t_k + s)|^p \} \\ &\leq NKC \mathbb{E} \{ \|\xi\|^p \} e^{-\Lambda(m-2)r}. \end{aligned} \quad (5.5.55)$$

Combining (5.5.52)–(5.5.55) gives

$$\mathbb{E} \{ \|x_{s_m}\|^p \} \leq 4^{p-1} \kappa KC_p \left[\mathbb{E} \{ \|x_{s_m}\|^p \} + \mathbb{E} \{ \|x_{s_{m-1}}\|^p \} \right] + L e^{-\Lambda(m-2)r}, \quad (5.5.56)$$

where $L = [K(r^p + C_p r^{\frac{p}{2}} + N) + 1] C \mathbb{E} \{ \|\xi\|^p \}$, a quantity independent of k . The rest of the proof is the same as the proof of Theorem 5.5.4. \square

Remark 5.5.4 Deriving almost sure exponential stability from exponential stability in moment under certain conditions on the growth of coefficients for stochastic functional differential equation is first done in [138] (see also [140, p.175–178]). The proofs here for

Theorem 5.5.4 and Theorem 5.5.5 are based on the proofs in [140], now taking switching and impulses into account. It can be seen that additional conditions on switching signal and the impulse function are necessary for the implication. \square

Corollary 5.5.2 *If $0 < p < 1$, then the same conditions as in Theorems 5.5.1– 5.5.3 together with the conditions in Theorem 5.5.5 imply (5.5.39), i.e., the trivial solution system (7.1.1) is also almost surely exponentially stable with its sample Lyapunov exponent not greater than $-\Lambda/p$.*

5.5.6 Examples

In this subsection, we will present two examples to illustrate the results obtained in this section. We shall omit mentioning the initial data, which are always assumed to be in $\mathcal{L}_{\mathcal{F}_{t_0}}^b$. For simplicity, only second moment stability ($p = 2$) is considered. Almost sure stability would follow from Theorem 5.5.4 under suitable assumptions.

Example 5.5.1 Consider the switched stochastic delay system

$$\begin{aligned} dx(t) &= [A_{i_k}x(t) + f_{i_k}(t, x(t), x(t - r(t)))]dt \\ &\quad + g_{i_k}(t, x(t), x(t - r(t)))dW(t), \quad t \neq t_k, \\ \Delta x(t) &= I_{j_k}(t, x_{t^-}), \quad t = t_k, \end{aligned} \quad (5.5.57)$$

where $\sigma = \{(t_k, i_k, j_k)\} \subset \mathcal{R}^+ \times I \times \mathcal{J}$ is an impulsive switching signal. Suppose that there exist positive constants $\alpha_i, \tilde{\alpha}_i, \beta_i$, and $\tilde{\beta}_i$ such that

$$|f_i(t, x, y)| \leq \alpha_i|x| + \tilde{\alpha}_i|y|, \quad (5.5.58)$$

and

$$|g_i(t, x, y)|^2 \leq \beta_i|x|^2 + \tilde{\beta}_i|y|^2, \quad (5.5.59)$$

for $i \in \mathcal{I}$ and $(t, x, y) \in \mathcal{R}^+ \times \mathcal{R}^n \times \mathcal{R}^n$. A single time-varying delay is given by $r(t)$, which is continuous on \mathcal{R}^+ and satisfies $0 \leq r(t) \leq r$ for some constant $r > 0$.

Stability Analysis. Assume that there exist real symmetric matrices P_i and Q_i such that P_i is positive definite and $A_i^T P_i + P_i A_i = Q_i$, for all $i \in \mathcal{I}$. Let $V_i(t, x) = x^T P_i x, i \in \mathcal{I}$. Then

$$\min_{i \in \mathcal{I}} \lambda_{\min}(P_i) |x|^2 \leq V_i(t, x) \leq \max_{i \in \mathcal{I}} \lambda_{\max}(P_i) |x|^2,$$

for all $(i, t, x) \in \mathcal{I} \times \mathcal{R} \times \mathcal{R}^n$. For $\phi \in \mathcal{L}_{\mathcal{F}_t}^2$, we have

$$\begin{aligned} \mathcal{L}V_i(t, \phi) &= 2\phi^T(0)P_i[A_i\phi(0) + f_i(t, \phi, \phi(-r(t)))] \\ &\quad + \text{trace}[g_i^T(t, \phi(0), \phi(-r(t)))P_i g_i(t, \phi(0), \phi(-r(t)))] \\ &\leq \lambda_{\max}(Q_i) |\phi(0)|^2 + 2\alpha_i \lambda_{\max}(P_i) |\phi(0)|^2 \\ &\quad + 2\tilde{\alpha}_i \lambda_{\max}(P_i) |\phi(0)\phi(-r(t))| \\ &\quad + \beta_i \lambda_{\max}(P_i) |\phi(0)|^2 + \tilde{\beta}_i \lambda_{\max}(P_i) |\phi(-r(t))|^2. \end{aligned} \quad (5.5.60)$$

If, for some $q > 1$, we have

$$\min_{i \in \mathcal{I}} \mathbb{E} \{ \phi^T(s) P_i \phi(s) \} \leq q \mathbb{E} \{ \phi^T(0) P_i \phi(0) \}, \quad \forall s \in [-r, 0],$$

which implies,

$$\min_{i \in \mathcal{I}} \lambda_{\min}(P_i) \mathbb{E} \{ |\phi(s)|^2 \} \leq q \mathbb{E} \{ \phi^T(0) P_i \phi(0) \}, \quad \forall s \in [-r, 0].$$

Hence, by (5.5.60),

$$\mathbb{E} \{ \mathcal{L}V_i(t, \phi) \} \leq \mu_i \mathbb{E} \{ V_i(t, \phi(0)) \}, \quad (5.5.61)$$

where $\mu_i = \kappa_i + q\tilde{\kappa}_i$, with

$$\kappa_i = \frac{\lambda_{\max}(Q_i)}{\lambda_{\max}(P_i)} + (2\alpha_i + \tilde{\alpha}_i + \beta_i) \frac{\lambda_{\max}(P_i)}{\lambda_{\min}(P_i)}, \quad (5.5.62)$$

and

$$\tilde{\kappa}_i = (\tilde{\alpha}_i + \tilde{\beta}_i) \frac{\lambda_{\max}(P_i)}{\min_{i \in \mathcal{I}} \lambda_{\min}(P_i)}. \quad (5.5.63)$$

Average Dwell-Time Approach

If $\kappa_i + \tilde{\kappa}_i < 0$ for all $i \in \mathcal{I}$, it is clear that each of the equations

$$-(\kappa_i + q\tilde{\kappa}_i) = \frac{\log(q)}{r}, \quad i \in \mathcal{I}, \quad (5.5.64)$$

has a unique solution q_i in $(1, -\kappa_i/\tilde{\kappa}_i)$. Let $q = \max_{i \in \mathcal{I}} q_i$, and $\mu = \max_{i \in \mathcal{I}} (-\mu_i)$. Then $q = e^{\mu r}$ and condition (ii) of Theorem 5.5.1 is satisfied. Assume, in this case, the impulse function is constantly zero. We have $V_i(t, x) \leq \max_{i \in \mathcal{I}} \lambda_{\max}(P_i P_j^{-1}) V_j(t, x)$, for all $(t, x) \in [t_0, \infty) \times \mathcal{R}^n$ and $i, j \in \mathcal{I}$, which implies that condition (b) of Theorem 5.5.1 is satisfied with $\rho_i = \max_{j \in \mathcal{I}} \lambda_{\max}(P_i P_j^{-1})$. By Theorem 5.5.1, the trivial solution of system

(5.5.57) is second moment globally uniformly exponentially stable on $\bigcap_{i \in \mathcal{I}} \mathcal{S}_a^i(\tau_i, N_0)$, where $\tau_i > \ln(\rho_i)/(-\mu_i)$, for all $i \in \mathcal{I}$, and its second moment Lyapunov exponent is not greater than $-\Lambda = -\min_{i \in \mathcal{I}}\{(-\mu_i) - \ln(\rho_i)/\tau_i\}$.

Impulsive Stabilization

If $\kappa_i + \tilde{\kappa}_i \geq 0$ for all $i \in \mathcal{I}$, we can consider the situation where all subsystems of (5.5.57) without impulses are unstable and seek impulsive stabilization for (5.5.57) by Theorem 5.5.2. For given Λ and r , we can find $q_i > 1$ such that

$$q_i = \exp(\Lambda r + \Lambda \delta_i + \mu_i \delta_i), \quad (5.5.65)$$

where $\mu_i = \kappa_i + q_i \tilde{\kappa}_i$, provided that δ_i is sufficiently small. Now according to Theorem 5.5.2, if we choose the impulses accordingly such that $\delta_i < -\ln(\rho_i)/(\Lambda + \mu_i)$, then the trivial solution of system (5.5.57) is second moment globally uniformly exponentially stable on $\bigcap_{i \in \mathcal{I}} \mathcal{S}_{\text{sup}}^i(\delta_i)$ with a second moment Lyapunov exponent not greater than $-\Lambda$.

Combined Hybrid Strategy

Suppose $\mathcal{I} = \mathcal{I}_s \cup \mathcal{I}_u$ with $\kappa_i + \tilde{\kappa}_i < 0$, for all $i \in \mathcal{I}_s$, and $\kappa_i + \tilde{\kappa}_i \geq 0$, for all $i \in \mathcal{I}_u$. Following case I, it is clear that, for each $i \in \mathcal{I}_s$, (5.5.64) has a unique solution q_i in $(1, -\kappa_i/\tilde{\kappa}_i)$. Let $q = \max_{i \in \mathcal{I}_s} q_i$ and $\mu = \max_{i \in \mathcal{I}_s} (-\mu_i)$. Then $q = e^{\mu r}$ and condition (ii) of Theorem 5.5.3 is satisfied. Choose the average dwell-time $\tau_i > \ln(\rho_i)/(-\mu_i)$ for $i \in \mathcal{I}_s$. We seek appropriate impulsive stabilization for the subsystems in \mathcal{I}_u . Let $\Lambda = \min_{i \in \mathcal{I}_s} \{(-\mu_i) > \ln(\rho_i)/\tau_i\}$. For each $i \in \mathcal{I}_u$ and a sufficiently small δ_i , we can find $q_i > 1$ such that

$$q_i = \exp(\mu r + \Lambda \delta_i + \mu_i \delta_i), \quad (5.5.66)$$

and $\mu_i = \kappa_i + q_i \tilde{\kappa}_i$. According to Theorem 5.5.3, if we choose the impulses such that $\delta_i < -\ln(\rho_i)/(\Lambda + \mu_i)$ for $i \in \mathcal{I}_u$, then the trivial solution of system (5.5.57) is second moment globally uniformly exponentially stable on

$$\left\{ \bigcap_{i \in \mathcal{I}_u} \mathcal{S}_{\text{sup}}(\delta_i) \right\} \cap \left\{ \bigcap_{i \in \mathcal{I}_s} \mathcal{S}_a^i(\tau, N_0) \right\},$$

with its second moment Lyapunov exponent not greater than $-\Lambda$. \square

The stability analysis for Example 5.5.1 can be summarized in the following proposition, while the notations are explained in the above argument.

Proposition 5.5.1 *The trivial solution of system (5.5.57) is second moment globally uniformly exponentially stable on*

- (i) $\bigcap_{i \in \mathcal{I}} \mathcal{S}_a^i(\tau_i, N_0)$, if $\kappa_i + \tilde{\kappa}_i < 0$ and $\tau_i > \ln(\rho_i)/(-\mu_i)$, for all $i \in \mathcal{I}$,
- (ii) $\bigcap_{i \in \mathcal{I}} \mathcal{S}_{\text{sup}}^i(\delta_i)$, if $\kappa_i + \tilde{\kappa}_i \geq 0$ and $\delta_i < -\ln(\rho_i)/(\Lambda + \mu_i)$, for all $i \in \mathcal{I}$,
- (iii) $\left\{ \bigcap_{i \in \mathcal{I}_u} \mathcal{S}_{\text{sup}}^i(\delta_i) \right\} \cap \left\{ \bigcap_{i \in \mathcal{I}_s} \mathcal{S}_a^i(\tau_i, N_0) \right\}$, if $\kappa_i + \tilde{\kappa}_i < 0$ and $\tau_i > \ln(\rho_i)/(-\mu_i)$, for all $i \in \mathcal{I}_s$, and $\kappa_i + \tilde{\kappa}_i \geq 0$ and $\delta_i < -\ln(\rho_i)/(\Lambda + \mu_i)$, for all $i \in \mathcal{I}_u$.

In all three cases, the second moment Lyapunov exponent is guaranteed to be not greater than $-\Lambda$. If, in addition, assumptions of Theorem 5.5.4 are satisfied, then the Lyapunov exponent is guaranteed to be not greater than $-\Lambda/2$.

Example 5.5.2 Let $\mathcal{I} = \{1, 2\}$, $\mathcal{J} = \mathcal{I} \times \mathcal{I}$, and choose

$$A_1 = \begin{pmatrix} -4.05 & 2.01 & -1.31 \\ -4.53 & -4.18 & -0.33 \\ -1.24 & 0.15 & -3.15 \end{pmatrix}, \quad A_2 = \begin{pmatrix} -0.87 & -0.64 & 0.05 \\ 0.87 & 0.85 & 2.70 \\ -1.52 & -3.37 & 0.59 \end{pmatrix}.$$

Consider a special case of (5.5.57),

$$dx(t) = [A_{i_k}x(t) + B_{i_k}x(t-r)]dt + C_{i_k}x(t-r)dW(t), \quad t > t_0, \quad (5.5.67)$$

with

$$I_{j_k}(t_k, \phi) = D(i_{k-1}, i_k)\phi(0),$$

where $r > 0$ is a constant, $B_i = C_i = E_3$ (E_3 is the 3×3 identity matrix), and $D(\cdot, \cdot)$ are 3×3 constant matrices.

Combined Hybrid Stabilization. We shall follow the same notations and argument as in Example 5.5.1. Choose $V_1(t, x) = V_2(t, x) = x^2$ (i.e., $P_1 = P_2 = I_3$). Taking $f_i(t, x, y) := B_i y$, $g_i(t, x, y) := C_i y$, it is clear that (5.5.58) and (5.5.59) are satisfied with $\tilde{\alpha}_i = \|B_i\|$, $\tilde{\beta}_i = \|C_i\|^2$, and $\alpha_i = \beta_i = 0$. We can compute, from (5.5.62) and (5.5.63),

$$\kappa_1 = \lambda_{\max}(A_1^T + A_1) + \|B_1\| = -3.0139, \quad \tilde{\kappa}_1 = \|B_1\| + \|C_1\|^2 = 2,$$

and

$$\kappa_2 = \lambda_{\max}(A_2^T + A_2) + \|B_2\| = 2.4545, \quad \tilde{\kappa}_2 = \|B_2\| + \|C_2\|^2 = 2.$$

Therefore, $\kappa_1 + \tilde{\kappa}_1 < 0$ and $\kappa_2 + \tilde{\kappa}_2 > 0$. Following case (iii) of Proposition 5.5.1, we can choose a combined hybrid strategy to stabilize system (5.5.67). The key steps are to find the average dwell-time condition τ_1 for the first mode, and the constants δ_2 and ρ_2 , which characterize, respectively, the impulse frequency and impulse strength for the second mode. Since $P_1 = P_2 = E_3$ and there are no impulses applied when the first mode is to be activated, we have that (5.5.8) (in condition (b) of Theorem 5.5.1), for $j = 1$, is satisfied with $\rho_1 = 1$ and $d(t) \equiv 1$, which, according to Remark 5.5.3, implies that there is essentially no average dwell-time restriction for the first mode. Solving (5.5.64) for $i = 1$ gives $q_1 = 1.3550$ and $\mu_1 = -0.3038$. Hence $\Lambda = \mu = 0.3038$. Choose $\delta_2 = 0.1$. Solving (5.5.66) for $i = 2$ gives $q_2 = 3.8765$. Hence $\mu_2 = 10.2075$. To introduce impulses for the second mode only, let

$$D(i, 1) = 0, \quad D(i, 2) = -0.5I_3, \quad i = 1, 2. \quad (5.5.68)$$

Therefore, (5.5.8) is satisfied with $\rho_2 = 0.25$ and $d(t) \equiv 1$. It is verified that

$$\delta_2 = 0.1 < 0.1319 = -\frac{\ln(\rho_2)}{\Lambda + \mu_2}.$$

According to Theorem 5.5.2, the trivial solution of (5.5.67) is second moment globally uniformly exponentially stable and its second moment Lyapunov exponent is not greater than -0.3038 . If, in addition, $\sigma = \{(t_k, i_k, j_k)\}$ satisfies an overall average dwell-time condition, Theorem 5.5.4 also guarantees that trivial solution of (5.5.67) is almost surely exponentially stable and its Lyapunov exponent is not greater than -0.1519 .

Numerical Simulation. With $\sigma \in \mathcal{S}_{\text{sup}}^2(0.1)$, typical samples of (5.5.67) are simulated and shown in Figure 5.10. It is demonstrated that the combined strategy can successfully stabilize system (5.5.67), which, in the absence of impulses, can be unstable, as shown in Figure 5.12.

Average Dwell-Time Approach. Now we illustrate, still by Example 5.5.2, that Theorem 5.5.1 can well cover switched systems with both stable and unstable modes and an average dwell-time switching would exponentially stabilize system (5.5.67). Solving (5.5.64) for $i = 1$ gives $q_1 = 1.3550$ and $\mu_1 = -0.3038$. Choose $q = q_1 = 1.3550$ and $\mu_2 = \kappa_2 + q\tilde{\kappa}_2 = 5.1645$. It is easy to verify that condition (ii) of Theorem 5.5.1 is satisfied. Suppose that there are no impulses, i.e., $D(i, i') = 0$ for all $i, i' \in \mathcal{I}$. Therefore, (5.5.8) is satisfied with $\rho_i = 1$ for $i = 1, 2$. According to Remark 5.5.3, there are no average dwell-time restrictions for both

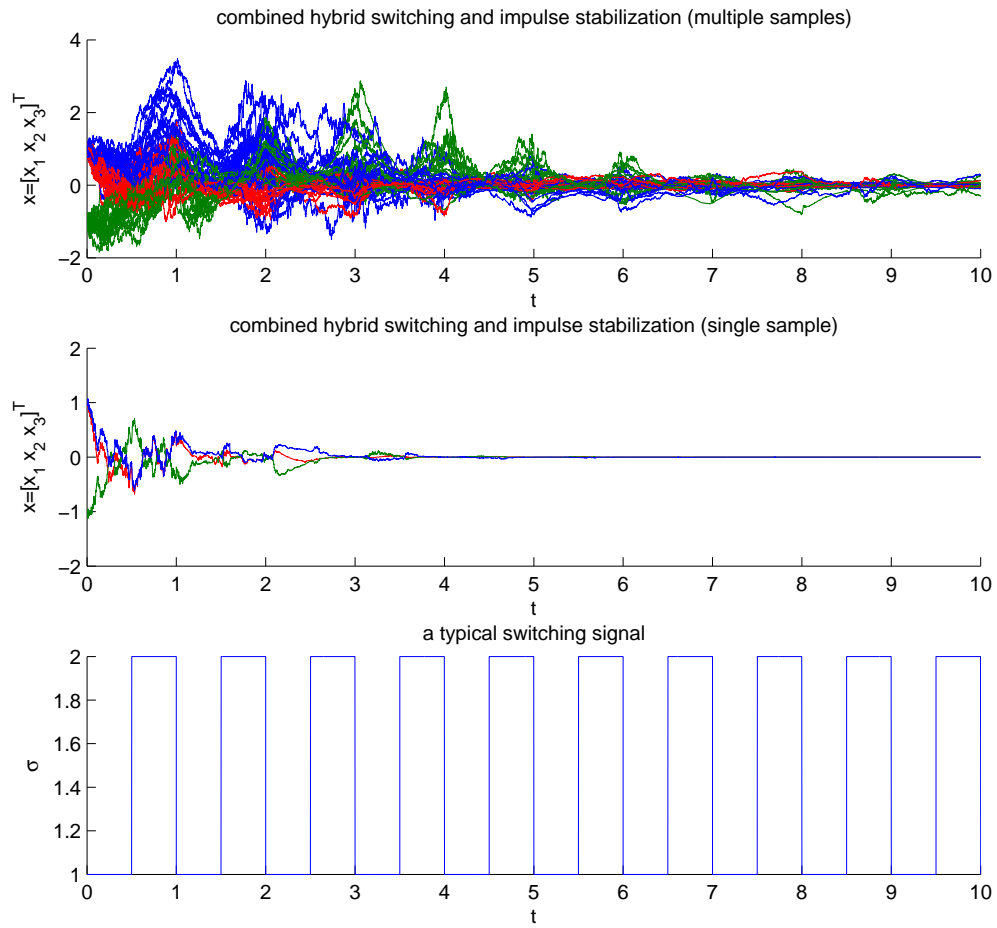

Figure 5.10 Simulation results for Example 5.5.1.

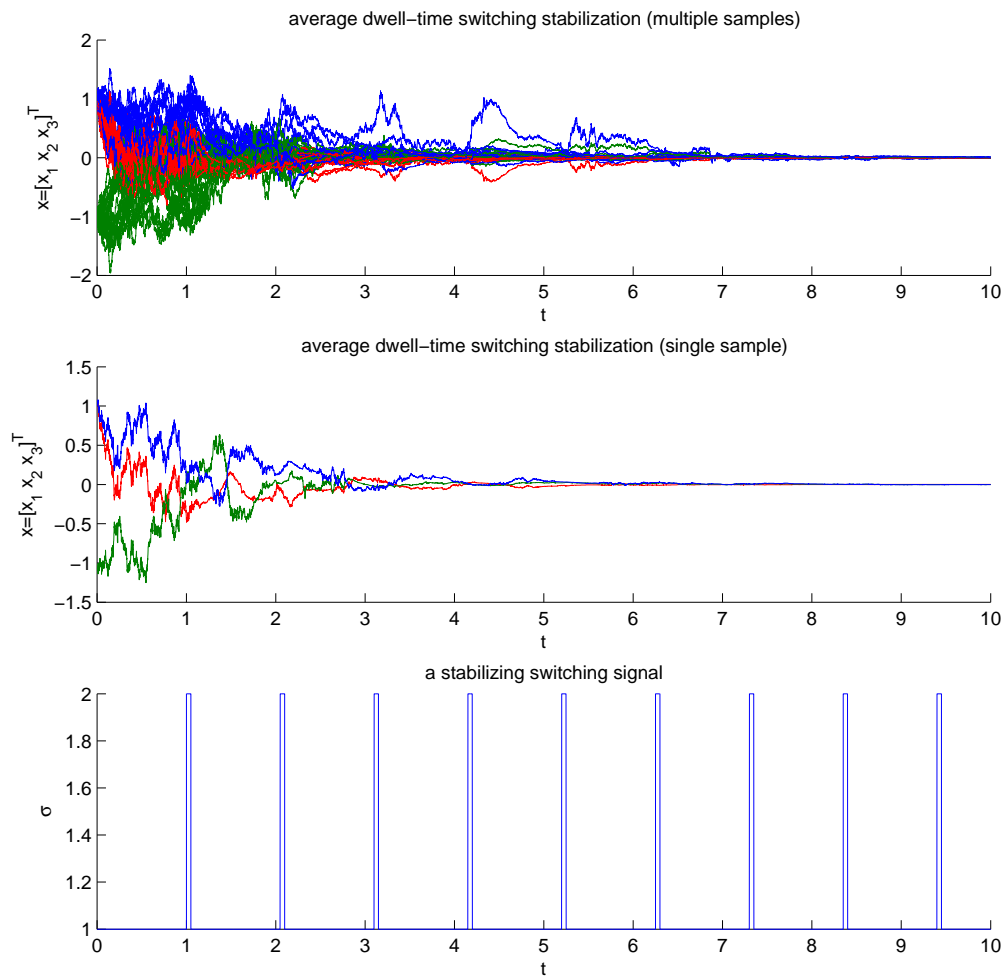

Figure 5.11 Simulation results for Example 5.5.1.

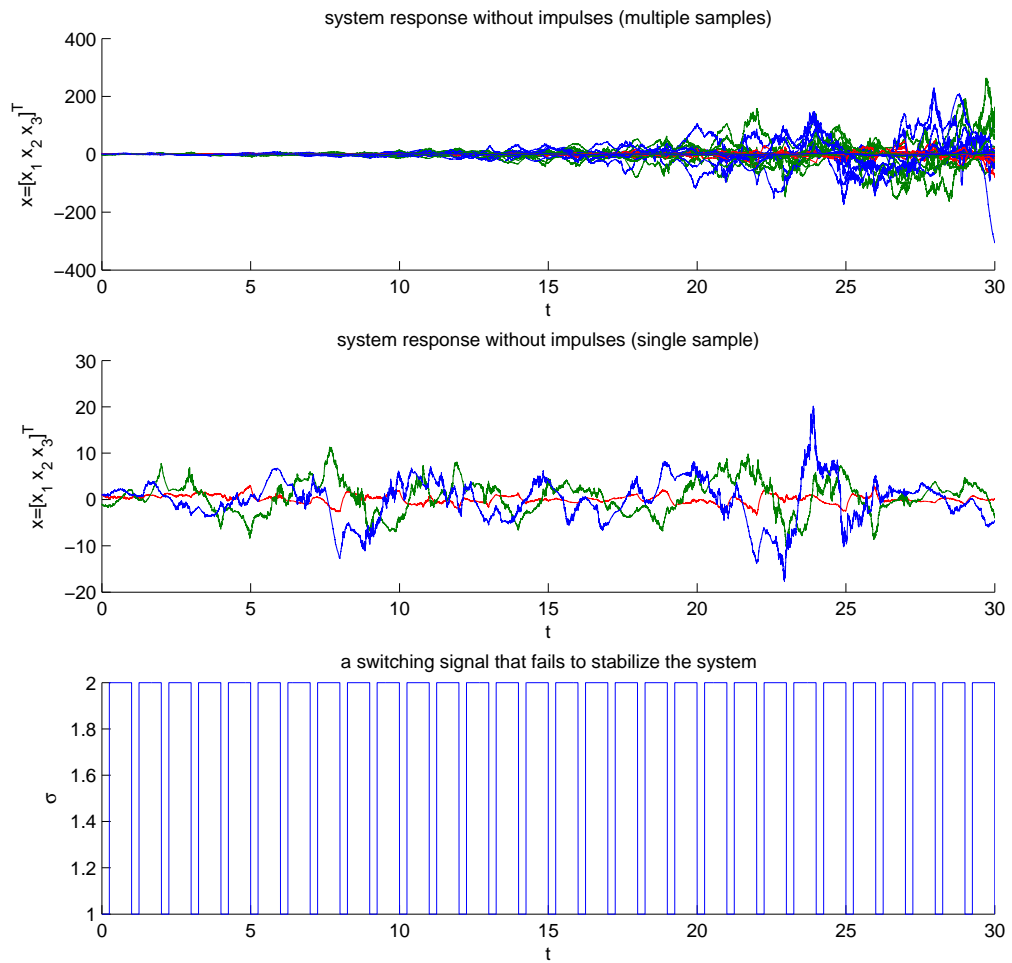

Figure 5.12 Simulation results for Example 5.5.1.

modes. The only condition in 5.5.1 remains to be verified is condition (c), which reads

$$\int_{t_0}^t \mu_{\sigma(s)} ds \leq -\lambda(t - t_0), \quad t \geq t_0, \quad (5.5.69)$$

for some constant $\lambda > 0$. To check (5.5.69), define, for $i = 1, 2$, $\pi_i(t)$ to be the total activation time of the i th mode up to time t . If $\sigma = \{(t_k, i_k, j_k)\}$ is such that

$$\frac{\pi_2(t)}{\pi_1(t)} \leq \vartheta, \quad t > t_0, \quad (5.5.70)$$

for some constant $\vartheta > 0$, then, by the identity $\pi_1(t) + \pi_2(t) = t - t_0$, we have

$$\pi_1(t) \geq \frac{t - t_0}{1 + \vartheta},$$

and, consequently,

$$\int_{t_0}^t \mu_{\sigma(s)} ds = \pi_1(t)\mu_1 + \pi_2(t)\mu_2 \leq \frac{(\mu_1 + \vartheta\mu_2)(t - t_0)}{1 + \vartheta}, \quad t > t_0.$$

Therefore, if we choose $\vartheta = 0.05 > 0$ such that $\mu_1 + \vartheta\mu_2 = -0.0456 < 0$, then (5.5.69) is verified and Theorem 5.5.1 guarantees that the trivial solution of (5.5.67) is second moment globally uniformly exponentially stable and its second moment Lyapunov exponent is not greater than -0.0456 . If, in addition, $\sigma = \{(t_k, i_k, j_k)\}$ satisfies an overall average dwell-time condition, Theorem 5.5.4 also guarantees that trivial solution of (5.5.67) is almost surely exponentially stable and its Lyapunov exponent is not greater than -0.0228 .

Numerical Simulation. With (σ, I) satisfying (5.5.70) with $\vartheta = 0.05$, typical samples of (5.5.67) are simulated and shown in Figure 5.11. It is demonstrated that the average dwell-time switching under the balance condition (5.5.70) can successfully stabilize system (5.5.67), which has both stable and unstable subsystems. Moreover, it is shown in Figure 5.12 that, a switching signal that fails to satisfy the balance condition (5.5.70) may also fail to stabilize the system. \square

5.6 Summary

In this chapter, we have presented a general mathematical framework for studying practical systems that may exhibit all the hybrid characteristics of impulse effects, switching, stochastic dynamics, and time delays.

Stability analysis and stabilization strategies have been proposed for such systems, which achieve both moment stability and almost sure stability under various circumstances. Given switched delay systems, Section 5.3 gives an impulsive stabilization scheme for such systems. In Section 5.4, a different stabilization approach is given, where a state-dependent switching signal is constructed to stabilize a family of unstable systems with time-delay. The results are extended to nonlinear systems and delay upper bounds have been quantified, which give various delay-dependent stability criteria.

Section 5.5 deals with general hybrid systems with time-delay and several Razumikhin-type theorems on stability have been established, each emphasizing a different situation. We first consider the situation that average dwell-time switching plays a dominant role in achieving stability. Here a balance between stable and unstable systems is formulated using an integral inequality that essentially proposes a class of generalized average dwell-time impulsive switching signals. We then consider the situation where average dwell-time switching fails and introduce impulse control scheme in this very general setting. Stability is guaranteed under a class of of impulsive switching signals with reverse average dwell-time. Finally, we consider the situation where both switching and impulse are used in the stabilization. Stabilizing impulses are only used when average dwell-time switching fails to stabilize certain subsystems.

While increasing attention has been paid to stability analysis and impulse control of stochastic delay systems, little has been paid to the existence and uniqueness of impulsive stochastic hybrid time-delay systems. It has been realized that there exist some key differences between continuous time-delay systems and impulsive time-delay systems. The same observation is true in the stochastic setting. By formulating the solutions in the space of piecewise continuous functions on the delay interval, we have established in Section 5.1 some existence and uniqueness results for general impulsive and switched hybrid stochastic time-delay systems. It should be pointed out that, in this thesis, the impulsive and switching signals are considered to be purely time-dependent and deterministic. The cases of state-dependent and random impulsive and switching signals can be topics of future research.

P A R T III

Applications

C H A **6** P T E R

Consensus in Dynamical Networks

While consensus problems have a long history in both computer science [134] and statistics [42], there has been a recent surge of interests among various disciplines of engineering and science in problems related to networked systems of multi-agents that emphasize consensus or agreement (see, e.g., [11], [15], [28], [29], [30], [46], [64], [77], [78], [76], [81], [127], [144], [148], [154], [153], [184]; see also [147] for a recent survey and extensive references therein). Consensus problems naturally arise when a group of agents, often distributed over a network, are seeking agreement upon a certain quantity of interest, such as attitude, position, velocity, voltage, direction, or temperature, depending on different applications.

Networked systems are often subject to environmental uncertainties and communication delays, which make it difficult or impossible for a networked agent to obtain timely and accurate information of its neighbors. Moreover, link gains/failures and formation reconfiguration make it necessary to address consensus problems for networks with switching network topology. The recent work of [77], [78], [76] studies stochastic consensus problems of networked agents, with or without switching topology, in the discrete-time setting using algorithms from stochastic approximation. In [127], the work of [77] is extended to the continuous-time setting, and both necessary and sufficient conditions for stochastic consensus have been obtained for networks that are balanced and contain a spanning tree (equivalent to strongly connected and balanced). Other work on consensus problems that explicitly takes into account measurement and environmental noises in different contexts includes [11], [17], [30], [43], [64], [153], [172], [173], and [184], in some of which the noises are modeled as deterministic but unknown disturbances (e.g., [11] and [43]). None

of the above mentioned work, however, has investigated stochastic consensus problems of networks with communication delays, either in discrete- or continuous-time setting, while delays are ubiquitous in communication networks.

The purpose and main contribution of this chapter are to investigate stochastic consensus problems with communication time-delays. Following the time-varying consensus protocol introduced in [77] for discrete-time systems and in [127] for continuous-time systems, both without communication delays, we propose a time-varying consensus protocol that takes into account both the measurement noises and general time-varying communication time-delays. We take a continuous-time approach using differential equations and stochastic calculus, and aim to provide conditions under which the proposed consensus protocol actually leads to consensus for networks with strongly connected and balanced topology. Moreover, the consensus results are extended to networks with arbitrary deterministic switching topology and with Markovian random switching topology. Explicit delay upper bounds for guaranteeing consensus are obtained in each case.

The rest of this chapter is organized as follows. In Section 6.1, we formulate the consensus problem, propose the consensus protocol, and introduce two notions of stochastic consensus. A Gronwall-Bellman-Halanay type inequality is established in Section 6.2, which plays an essential role in proving the consensus results. The main consensus results are presented in Section 6.3, followed by demonstrations through numerical simulations in Section 6.4. This chapter is concluded by Section 6.5, with a discussion on some possible future research along the line of this chapter.

6.1 Problem Formulation and Consensus Protocols

6.1.1 Network Topology

The interaction topology of a network of n -agents is modeled by a *weighted digraph* (or directed graph) $\mathcal{G} = (\mathcal{V}, \mathcal{E}, \mathcal{A})$ of order n with set of nodes $\mathcal{V} = \{v_1, \dots, v_n\}$, set of edges $\mathcal{E} \subset \mathcal{V} \times \mathcal{V}$, and a weighted adjacent matrix $\mathcal{A} = [a_{ij}]_{n \times n}$ with nonnegative elements a_{ij} . An edge of \mathcal{G} is denoted by $e_{ij} = (v_i, v_j)$. An edge e_{ij} exists if and only if $a_{ij} > 0$. It is assumed that $a_{ii} = 0$ for $i = 1, \dots, n$. The set of neighbors of a node v_i is denoted by $\mathcal{N}_i = \{v_j \in \mathcal{V} : (v_j, v_i) \in \mathcal{E}\}$. Let $x_i \in \mathcal{R}$ denote the value of node v_i , which is a scalar quantity of interest. Denote the set $\{1, \dots, n\}$ by \mathcal{I} . The *graph Laplacian* \mathcal{L} of the network

is defined by

$$\mathcal{L} = D - \mathcal{A}, \quad (6.1.1)$$

where $D = \text{diag}\{d_1, \dots, d_n\}$ is the degree matrix of \mathcal{G} with diagonal elements $d_i = \sum_{j \neq i} a_{ij}$ and \mathcal{A} is the weighted adjacent matrix. A digraph (and the corresponding network) is **strongly connected** if there is a directed path connecting any two arbitrary nodes in the graph. A digraph (and the corresponding network) is said to be **balanced** if $\sum_{j \neq i} a_{ij} = \sum_{j \neq i} a_{ji}$ for all $i \in \mathcal{I}$.

6.1.2 Consensus Protocols

Consider each node of the graph to be a dynamic agent with dynamics

$$\dot{x}_i = u_i, \quad i \in \mathcal{I}, \quad (6.1.2)$$

where the state feedback $u_i = u_i(x_{i_1}, \dots, x_{i_k})$ is called a **protocol** with topology \mathcal{G} if the set of nodes $\{x_{i_1}, \dots, x_{i_k}\}$ are all taken from the set $\{v_i\} \cup \mathcal{N}_i$, i.e., only the information of v_i itself and its neighbors are available in forming the state feedback for the node v_i .

We consider the following consensus protocol in [148]

$$u_i = \sum_{v_j \in \mathcal{N}_i} a_{ij}(x_j - x_i), \quad i \in \mathcal{I}. \quad (6.1.3)$$

The above protocol requires that agent i can obtain information from its neighbors in \mathcal{N}_i timely and accurately, i.e., it assumes zero communication time-delay and accurate information exchange among agents. Let y_{ji} be a measurement of x_j by x_i given by

$$y_{ji} = x_j + \sigma_{ji} \dot{w}_{ji}(t), \quad i \in \mathcal{I}, \quad (6.1.4)$$

where $\{\dot{w}_{ji}(t) : i, j = 1, \dots, n\}$ are independent standard white noises and $\sigma_{ji} \geq 0$ represent the noise intensity. Replacing x_j in (6.1.3) with the noisy measurement y_{ji} gives the following stochastic consensus protocol

$$u_i = \sum_{v_j \in \mathcal{N}_i} a_{ij}(y_{ji} - x_i), \quad i \in \mathcal{I}. \quad (6.1.5)$$

If, in addition, time-varying communication delays are considered, we propose the following delayed stochastic consensus protocol

$$u_i(t) = c(t) \sum_{v_j \in \mathcal{N}_i} a_{ij}[y_{ji} - x_i(t - \tau_{ij}(t))], \quad i \in \mathcal{I}, \quad (6.1.6)$$

where

$$y_{ji} = x_j(t - \tau_{ij}(t)) + \sigma_{ji}\dot{w}_{ji}(t), \quad i \in \mathcal{I},$$

and the time-varying delays $\tau_{ij}(t)$ lie in $[0, \tau]$ for some $\tau > 0$ and are assumed to be continuous in t . The function $c : \mathcal{R}^+ \rightarrow \mathcal{R}^+$ in (6.1.6) is a piecewise continuous function satisfying

$$\int_0^\infty c(s)ds = \infty \quad \text{and} \quad \int_0^\infty c^2(s)ds < \infty. \quad (6.1.7)$$

The role of the function $c(t)$ is to attenuate the noise effects as $t \rightarrow \infty$. Condition (6.1.7), on the one hand, implies that $c(t)$ is vanishing as $t \rightarrow \infty$, but, on the other hand, not too fast due to $\int_0^\infty c(s)ds = \infty$. Without loss of generality, we can assume that $\sup_{t \geq 0} c(t) \leq 1$. If \mathcal{N}_i is fixed, (6.1.6) gives a **fixed topology protocol**. If \mathcal{N}_i is time-varying, we have a **switching topology protocol**. The communication delays and noisy measurements in the protocol (6.1.6) are illustrated by Figure 6.1.

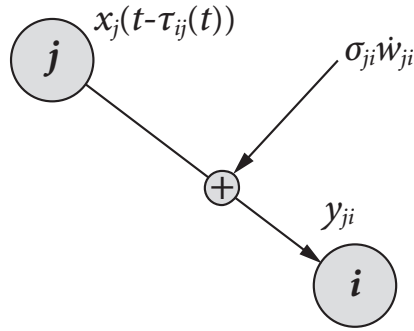

Figure 6.1 Delayed measurements with additive noises.

6.1.3 Network Dynamics

If the time-delays are uniform, i.e., $\tau_{ij}(t) = \tau(t)$ for all $i, j \in \mathcal{I}$, the collective dynamics of system (6.1.2) under the consensus protocol (6.1.6) can be written in a compact form of a stochastic delay differential equation (SDDE) as

$$dx(t) = c(t)[-Lx(t - \tau(t))dt + \Theta dW(t)], \quad (6.1.8)$$

where $W(t)$ is an n^2 -dimensional standard Wiener process, L is the graph Laplacian of the network, and $\Theta \in \mathcal{R}^{n \times n^2}$ is a constant matrix defined by $\Theta = \text{diag}(\Theta_1, \dots, \Theta_n)$, where Θ_i is an n -dimensional row vector given by $\Theta_i = [a_{i1}\sigma_{1i} \ a_{i2}\sigma_{2i} \ \dots \ a_{in}\sigma_{ni}]$.

6.1.4 Consensus Notions

We introduce the following notions of consensus for the multi-agent systems (6.1.2) under the consensus protocol (6.1.6) in an uncertain environment.

Definition 6.1.1 Given $p > 0$, the agents in (6.1.2) are said to reach **average-consensus in the p th moment** if $E\{|x_i(t)|^p\} < \infty$ for all $t \geq 0$ and $i \in \mathcal{I}$ and there exists a random variable x^* such that $E\{x^*\} = \text{avg}(x(0)) = \sum_{i=1}^n x_i(0)/n$ and $\lim_{t \rightarrow \infty} E\{|x_i(t) - x^*|^p\} = 0$ for all $i \in \mathcal{I}$. Particularly, if $p = 2$, the agents are said to reach **mean square average-consensus**. \square

Definition 6.1.2 The agents in (6.1.2) are said to reach **almost sure average-consensus** if there exists a random variable x^* such that $E\{x^*\} = \text{avg}(x(0)) = \sum_{i=1}^n x_i(0)/n$ and $\lim_{t \rightarrow \infty} x_i(t) = x^*$ almost surely for all $i \in \mathcal{I}$. \square

In [77], the authors defined and investigated both mean square consensus and almost sure consensus (called strong consensus) in the discrete-time setting, without emphasizing average-consensus and considering communication delays. Continuous-time mean square average-consensus has been defined and studied in [127], without considering communication delays.

6.2 A Gronwall-Bellman-Halanay Type Inequality

In this section, we present a generalized Gronwall-Bellman-Halanay type inequality for estimating a function based on a delay differential inequality, which is essential to prove the main theorem and might be of independent interest as well, since it generalizes the classical Halanay inequality in the sense that it can be applied to non-autonomous systems.

Lemma 6.2.1 Let t_0 and r be nonnegative constants. Let $m : [t_0 - r, \infty) \rightarrow \mathcal{R}^+$ be continuous and satisfy

$$D^+ m(t) \leq \gamma(t) - \mu c(t)m(t) + \lambda c(t) \sup_{-r \leq s \leq 0} m(t+s), \quad (6.2.1)$$

on $[t_0, \infty)$, where γ and c are piecewise continuous functions with $\gamma(t) \geq 0$ and $c(t) \in (0, 1]$ for all $t \geq 0$, and μ and λ are constants satisfying $\mu > \lambda > 0$. Then

$$m(t) \leq m_0 \exp \left\{ -\rho \int_{t_0}^t c(s) ds \right\} + \int_{t_0}^t \exp \left\{ -\rho \int_s^t c(r) dr \right\} \gamma(s) ds, \quad (6.2.2)$$

holds on $[t_0, \infty)$, where $\rho > 0$ is the root of $-\rho = -\mu + \lambda e^{\rho r}$ and $m_0 = \sup_{-r \leq s \leq 0} m(t_0+s)$.

Proof. Define

$$u(t) = \begin{cases} \text{RHS of (6.2.2)}, & t \in [t_0, \infty), \\ m_0, & t \in [t_0 - r, t_0), \end{cases}$$

and

$$t^* = t^*(\varepsilon) = \inf \{t \in [t_0, \infty) : m(t) > u(t) + \varepsilon\},$$

where $\varepsilon > 0$ is an arbitrary positive constant. Note that, if $t^* = \infty$ for all ε , then the lemma is proved. Suppose $t^* \in [t_0, \infty)$ for some $\varepsilon > 0$. By the definition of t^* and the continuity of $m(t)$, we have $m(t^*) = u(t^*) + \varepsilon$ and

$$\sup_{-r \leq s \leq 0} m(t^* + s) \leq \sup_{-r \leq s \leq 0} u(t^* + s) + \varepsilon \leq e^{\rho r} u(t^*) + \varepsilon < e^{\rho r} m(t^*). \quad (6.2.3)$$

Therefore, by (6.2.1) and (6.2.3),

$$D^+[m - u](t^*) < (-\mu + \lambda e^{\rho r} + \rho)c(t^*)m(t^*) - \rho c(t^*)\varepsilon = -\rho c(t^*)\varepsilon < 0, \quad (6.2.4)$$

which contradicts how t^* is defined. Therefore, we must have $t^* = \infty$ for all $\varepsilon > 0$ and the lemma is proved. \square

6.3 Consensus Results

In this section, we analyze the consensus properties of the dynamics of system (6.1.2).

6.3.1 Networks with Fixed Topology

We start by analyzing networks with fixed topology, i.e., the weighted graph $\mathcal{G} = (\mathcal{V}, \mathcal{E}, \mathcal{A})$ is time-invariant.

Theorem 6.3.1 *Suppose that \mathcal{G} is a strongly connected and balanced digraph with \mathcal{L} as its Laplacian. Let $\lambda_2(\mathcal{L})$ denote the second smallest eigenvalue of $\mathcal{L}_s = (\mathcal{L} + \mathcal{L}^T)/2$. If*

$$\tau < \frac{\lambda_2(\mathcal{L})}{\|\mathcal{L}^2\|}, \quad (6.3.1)$$

where $\|\cdot\|$ denotes the spectral norm, then the consensus protocol (6.1.6) leads to mean square average-consensus for the agents in (6.1.2).

To prove this theorem, we introduce a so-called displacement vector as in [148] and [127]

$$\delta(t) = x(t) - \mathbf{1}\alpha(t) = (I - J)x(t), \quad (6.3.2)$$

where $\mathbf{1}$ stands for the column n -vector with all ones, $\alpha(t) = \text{avg}(x(t)) = \frac{1}{n}\mathbf{1}^T x(t) = \frac{1}{n} \sum_{i=1}^n x_i(t)$, I is the $n \times n$ identity matrix, and $J = \frac{1}{n}\mathbf{1}\mathbf{1}^T$. It is easy to see that

$$\mathbf{1}^T \delta(t) = \sum_{i=1}^n x_i(t) - n\alpha(t) = 0, \quad t \geq 0. \quad (6.3.3)$$

The dynamics of $\delta(t)$ is given by

$$d\delta(t) = c(t)[- \mathcal{L}\delta(t - \tau(t))dt + (I - J)\Theta dW(t)], \quad (6.3.4)$$

where we have used the fact that $\mathbf{1}^T \mathcal{L} = \mathcal{L}\mathbf{1} = 0$. The consensus analysis relies on the Lyapunov function candidate

$$V(t) = \delta^T(t)\delta(t) = |\delta(t)|^2, \quad t \geq 0.$$

The quantity $\lambda_2(\mathcal{L})$, called the **algebraic connectivity** of the graph \mathcal{G} , was originally introduced in [47] for undirected graphs and later extended to digraphs in [148]. The following property of the graph Laplacian \mathcal{L} for strongly connected and balanced digraphs (see Theorem 7 of [148]),

$$\delta^T \mathcal{L} \delta \geq \lambda_2(\mathcal{L}) |\delta|^2, \quad \forall \mathbf{1}^T \delta = 0, \quad (6.3.5)$$

plays an important role in ensuring that the protocol (6.1.6) leads to consensus of the agents in (6.1.2).

Proof (Theorem 6.3.1). Applying Itô's formula to $V(t)$ in view of (6.3.2), we have

$$\begin{aligned} dV(t) &= -2c(t)\delta^T(t)\mathcal{L}\delta(t)dt + 2c(t)\delta^T(t)\mathcal{L}[\delta(t) - \delta(t - \tau(t))]dt \\ &\quad + C_0 c^2(t)dt + 2c(t)\delta^T(t)(I - J)\Theta dW(t), \end{aligned} \quad (6.3.6)$$

where

$$C_0 = \text{trace}[(I - J)^2 \Theta \Theta^T]. \quad (6.3.7)$$

Equation (6.3.6) implies that

$$\begin{aligned} \mathbb{E}\{V(t)\} - \mathbb{E}\{V(\tau)\} &= -2 \int_{\tau}^t c(s) \mathbb{E}\{\delta^T(s)\mathcal{L}\delta(s)\} ds \\ &\quad + 2 \int_{\tau}^t c(s) \mathbb{E}\{\delta^T(s)\mathcal{L}[\delta(s) - \delta(s - \tau(s))]\} ds \\ &\quad + C_0 \int_{\tau}^t c^2(s) ds. \end{aligned} \quad (6.3.8)$$

Let $m(t) = E\{V(t)\}$ for $t \geq 0$. Writing the above integral equation in differential form gives

$$\begin{aligned} D^+ m(t) &= -2c(t) E\{\delta^T(t) \mathcal{L}\delta(t)\} + C_0 c^2(t) \\ &\quad + 2c(t) E\{\delta^T(t) \mathcal{L}[\delta(t) - \delta(t - \tau(t))]\}. \end{aligned} \quad (6.3.9)$$

Note that

$$E\{\delta^T(t) \mathcal{L}\delta(t)\} \geq \lambda_2(\mathcal{L})EV(t),$$

and

$$2E\{\delta^T(t) \mathcal{L}[\delta(t) - \delta(t - \tau(t))]\} \leq \varepsilon E\{V(t)\} + \frac{1}{\varepsilon} E\{\mathcal{L}[\delta(t) - \delta(t - \tau(t))]\}^2,$$

where $\varepsilon > 0$ is a constant to be determined later. On the other hand, equation (6.3.4) implies that

$$\begin{aligned} &E\{\mathcal{L}[\delta(t) - \delta(t - \tau(t))]\}^2 \\ &\leq (1 + \beta) E\left\{\left|\int_{t-\tau(t)}^t c(s) \mathcal{L}^2 \delta(s - \tau(s)) ds\right|^2\right\} \\ &\quad + (1 + \frac{1}{\beta}) E\left\{\left|\int_{t-\tau(t)}^t c(s) \mathcal{L}(I - J) \Theta dW(s)\right|^2\right\} \\ &\leq (1 + \beta) \tau \|\mathcal{L}^2\|^2 \int_{t-\tau}^t E\{|\delta(s - \tau(s))|^2\} ds + (1 + \frac{1}{\beta}) \tau C_0 \|\mathcal{L}^2\| \int_{t-\tau}^t c^2(s) ds \\ &\leq (1 + \beta) \tau^2 \|\mathcal{L}^2\|^2 \sup_{-2r \leq s \leq 0} E\{V(t + s)\} + (1 + \frac{1}{\beta}) \tau C_0 \|\mathcal{L}^2\| \int_{t-\tau}^t c^2(s) ds, \end{aligned}$$

where $\beta > 0$ is a constant to be chosen later. Putting the above three estimates together into (6.3.9) and setting $\varepsilon = \tau \|\mathcal{L}^2\|$, we obtain

$$\begin{aligned} D^+ m(t) &\leq -2\lambda_2(\mathcal{L})c(t)m(t) + 2(1 + \beta)\tau \|\mathcal{L}^2\|c(t) \sup_{-2r \leq s \leq 0} m(t + s) \\ &\quad + (1 + \frac{1}{\beta})C_0^2 \int_{t-\tau}^t c^2(r)dr + C_0 c^2(t), \quad t \geq \tau. \end{aligned}$$

Inequality (6.3.1) implies that we can choose $\beta > 0$ sufficiently small such that $2\lambda_2(\mathcal{L}) > (2 + \beta)\tau \|\mathcal{L}^2\|$. Therefore, there exists $\rho > 0$ such that $-2\lambda_2(\mathcal{L}) + (2 + \beta)\tau \|\mathcal{L}^2\|e^{2\rho\tau} = -\rho$.

Lemma 6.2.1 shows that

$$m(t) \leq m_0 \exp\left\{-\rho \int_{\tau}^t c(s) ds\right\} + \int_{\tau}^t \exp\left\{-\rho \int_s^t c(r) dr\right\} \gamma(s) ds, \quad (6.3.10)$$

on $[\tau, \infty)$ with

$$m_0 = \sup_{-\tau \leq s \leq \tau} m(s), \quad \gamma(t) = \left(1 + \frac{1}{\beta}\right) C_0^2 \int_{t-\tau}^t c^2(r) dr + C_0 c^2(t).$$

It follows from (6.1.7) that

$$\exp \left\{ -\rho \int_{\tau}^t c(s) ds \right\} \rightarrow 0, \quad (6.3.11)$$

as $t \rightarrow \infty$. On the other hand, note that, for all $t \geq T \geq \tau$, we have

$$\begin{aligned} & \int_{\tau}^t \exp \left\{ -\rho \int_s^t c(r) dr \right\} \int_{s-\tau}^s c^2(r) dr ds \\ &= \int_{\tau}^T \exp \left\{ -\rho \int_s^t c(r) dr \right\} \int_{s-\tau}^s c^2(r) dr ds \\ & \quad + \int_T^t \exp \left\{ -\rho \int_s^t c(r) dr \right\} \int_{s-\tau}^s c^2(r) dr ds \\ &\leq \exp \left\{ -\rho \int_T^t c(r) dr \right\} \int_{\tau}^{\infty} \int_{s-\tau}^s c^2(r) dr ds + \int_T^{\infty} \int_{s-\tau}^s c^2(r) dr ds, \end{aligned} \quad (6.3.12)$$

and, similarly,

$$\begin{aligned} & \int_{\tau}^t \exp \left\{ -\rho \int_s^t c(r) dr \right\} c^2(s) ds \\ &\leq \exp \left\{ -\rho \int_T^t c(r) dr \right\} \int_{\tau}^{\infty} c^2(s) ds + \int_T^{\infty} c^2(s) ds. \end{aligned} \quad (6.3.13)$$

In view of (6.1.7), for fixed T ,

$$\exp \left\{ -\rho \int_T^t c(s) ds \right\} \rightarrow 0, \quad (6.3.14)$$

as $t \rightarrow \infty$, and

$$\int_{\tau}^{\infty} \int_{s-\tau}^s c^2(r) dr ds \leq \int_0^{\infty} c^2(r) \int_r^{r+\tau} ds dr = \tau \int_0^{\infty} c^2(r) dr < \infty. \quad (6.3.15)$$

Therefore, both

$$\int_T^{\infty} \int_{s-\tau}^s c^2(r) dr ds \rightarrow 0, \quad \int_T^{\infty} c^2(s) ds \rightarrow 0, \quad (6.3.16)$$

as $T \rightarrow \infty$. Putting (6.3.14), (6.3.15), and (6.3.16) into (6.3.12) and (6.3.13), we have shown

$$\int_{\tau}^t \exp \left\{ -\rho \int_s^t c(r) dr \right\} \gamma(s) ds \rightarrow 0, \quad (6.3.17)$$

as $t \rightarrow \infty$. Combining (6.3.11) and (6.3.17) into (6.3.10), we finally get $E\{V(t)\} = m(t) \rightarrow 0$ as $t \rightarrow \infty$.

Now note that

$$\alpha(t) = \frac{1}{n} \mathbf{1}^T x(t) = \frac{1}{n} \mathbf{1}^T x(0) + \int_0^t \frac{1}{n} c(s) \mathbf{1}^T (I - J) \Theta dW(s).$$

Since

$$E \left\{ \int_0^t \frac{1}{n} \mathbf{1}^T (I - J) \Theta dW(s) \right\}^2 = \frac{1}{n} C_0 \int_0^t c^2(s) ds < \int_0^\infty c^2(s) ds < \infty,$$

where C_0 is defined by (6.3.7), it follows that α is an L^2 -bounded martingale. Doob's martingale convergence theorem guarantees there exists a random variable x^* with $E\{|x^*|^2\} < \infty$ such that

$$\lim_{t \rightarrow \infty} \alpha(t) = x^* \text{ a.s.} \quad \text{and} \quad \lim_{t \rightarrow \infty} E\{|\alpha(t) - x^*|^2\} = 0.$$

Moreover, $E\{x^*\} = E\{\alpha(t)\} = E\{\alpha(0)\} = \sum_{i=1}^n x_i(0)/n$. On the other hand, for all $i \in \mathcal{I}$,

$$\begin{aligned} |x_i(t) - x^*|^2 &\leq 2|x_i(t) - \alpha(t)|^2 + 2|\alpha(t) - x^*|^2 \\ &= 2|\delta_i(t)|^2 + 2|\alpha(t) - x^*|^2 \\ &\leq 2V(t) + 2|\alpha(t) - x^*|^2. \end{aligned}$$

It follows from both $E\{V(t)\} \rightarrow 0$ and $E\{|\alpha(t) - x^*|^2\} \rightarrow 0$ that

$$E\{|x_i(t) - x^*|^2\} \rightarrow 0,$$

as $t \rightarrow \infty$. Moreover, it is easy to check that

$$E\{|x_i(t)|^2\} \leq E\{V(t)\} + E\{\alpha^2(t)\} < \infty, \quad t \geq 0.$$

Therefore, mean square consensus is reached and the proof is complete. \square

6.3.2 Networks with Arbitrarily Switching Topology

In general, the network topology specified by the weighted digraph $\mathcal{G} = (\mathcal{V}, \mathcal{E}, \mathcal{A})$ can be time-varying due to node and link failures/creations, packet-loss, asynchronous consensus, formation reconfiguration, evolution, and flocking as pointed out in [147]. To effectively model the dynamic changing of the network structures, we consider a collection of digraphs and introduce a general time-dependent switching signal, either deterministic or stochastic, to switch the network structures among the collection of digraphs.

We consider deterministic time-dependent switching in this subsection. Let \mathcal{I} denote a finite index set and $\{\mathcal{G}_p : p \in \mathcal{I}\}$ a family of digraphs. Let $\sigma : \mathcal{R}^+ \rightarrow \mathcal{I}$ be a piecewise constant and right-continuous function called a **switching signal**. The collective dynamics (6.1.8) can be written as a switched system

$$dx(t) = c(t) \left[-\mathcal{L}_{\sigma} x(t - \tau(t)) dt + \Theta dW(t) \right], \quad (6.3.18)$$

where \mathcal{L}_p ($p \in \mathcal{I}$) is the corresponding graph Laplacian of \mathcal{G}_p .

Theorem 6.3.2 *Suppose that each \mathcal{G}_p in $\{\mathcal{G}_p : p \in \mathcal{I}\}$ is a strongly connected and balanced digraph with \mathcal{L}_p as its Laplacian. Let $\lambda_2(\mathcal{L}_p)$ denote the second smallest eigenvalue of $\mathcal{L}_s^p = (\mathcal{L}_p + \mathcal{L}_p^T)/2$. If*

$$\tau < \frac{\min_{p \in \mathcal{I}} \lambda_2(\mathcal{L}_p)}{\max_{p \in \mathcal{I}} \|\mathcal{L}_p^2\|}, \quad (6.3.19)$$

then the consensus protocol (6.1.6) leads to mean square average-consensus for the agents in (6.1.2) under any arbitrary deterministic switching signals.

Proof. Let $\sigma(t)$, $t \geq 0$, be a given switching signal. Then $V(t)$ can serve as a common Lyapunov function for the displacement dynamics

$$d\delta(t) = c(t) \left[-\mathcal{L}_{\sigma(t)} \delta(t - \tau(t)) dt + (I - J) \Theta dW(t) \right], \quad (6.3.20)$$

which follows from (6.3.18). Repeating the same argument as in the proof of Theorem 6.3.1, we can obtain

$$\begin{aligned} D^+ m(t) &\leq -2 \min_{p \in \mathcal{I}} \lambda_2(\mathcal{L}_p) c(t) m(t) \\ &\quad + (2 + \beta) \tau \max_{p \in \mathcal{I}} \|\mathcal{L}_p^2\| c(t) \sup_{-2r \leq s \leq 0} m(t + s) \\ &\quad + \left(1 + \frac{1}{\beta}\right) C_0^2 \int_{t-\tau}^t c^2(r) dr + C_0 c^2(t), \quad t \geq \tau. \end{aligned}$$

Since we can choose $\beta > 0$ such that $2 \min_{p \in \mathcal{I}} \lambda_2(\mathcal{L}_p) > (2 + \beta) \tau \max_{p \in \mathcal{I}} \|\mathcal{L}_p^2\|$, there exists $\rho > 0$ such that $-2\lambda_2(\mathcal{L}) + (2 + \beta) \tau \|\mathcal{L}^2\| e^{2\rho\tau} = -\rho$. Lemma 6.2.1 implies that the same estimate (6.3.10) holds and the rest of the proof is essentially the same as the proof of Theorem 6.3.1. \square

6.3.3 Networks with Markovian Switching Topology

Hybrid systems driven by continuous-time Markov chains have long been used to model many practical systems where abrupt changes in their structures and parameters caused by phenomena such as component failures and repairs as pointed out in [137]. In this subsection, we consider the case where the switching signal is modeled by a continuous-time Markov chain. More specifically, let $\sigma : \mathcal{R}^+ \rightarrow \mathcal{I}$ be a right-continuous Markov chain with generator $\Gamma = (\gamma_{ij})_{N \times N}$ given by

$$P(\sigma(t + \Delta) = j \mid \sigma(t) = i) = \begin{cases} \gamma_{ij}\Delta + o(\Delta), & i \neq j, \\ 1 + \gamma_{ii}\Delta + o(\Delta), & i = j, \end{cases}$$

where $\Delta > 0$, N is the cardinality of \mathcal{I} , $\gamma_{ij} \geq 0$ for $i \neq j$, and $\gamma_{ii} = -\sum_{i \neq j} \gamma_{ij}$. Such switching signals are called *Markovian switching signals*.

Theorem 6.3.3 *If all the conditions in Theorem 6.3.2 are satisfied, then the consensus protocol (6.1.6) leads to mean square average-consensus for the agents in (6.1.2) under any Markovian switching signals.*

Proof. The proof is essentially the same as that of Theorem 6.3.2, except that we should apply the generalized Itô's formula [137, Theorem 1.45] due to the Markovian switching. Since a common Lyapunov function $V = |\delta|^2$ is used, we obtain the same integral equation as (6.3.8) for the expectation $E\{V(t)\}$ with $\mathcal{L}_{\sigma(s)}$ in place of \mathcal{L} . The rest of the proof is the same.

6.4 Simulation Results

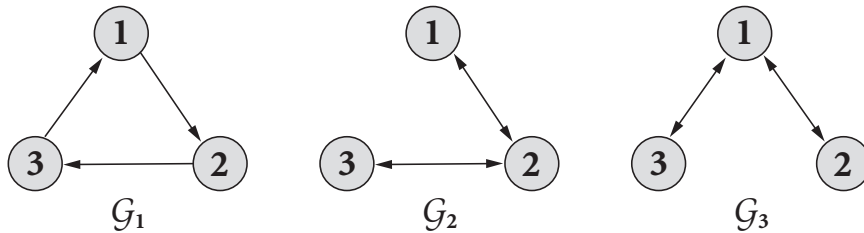

Figure 6.2 Three different network topologies of 3-agents.

Consider dynamical networks of three agents. Figure 6.2 shows three different topologies denoted by the family $\{\mathcal{G}_1, \mathcal{G}_2, \mathcal{G}_3\}$. While all digraphs in the figure have 0-1 weights,

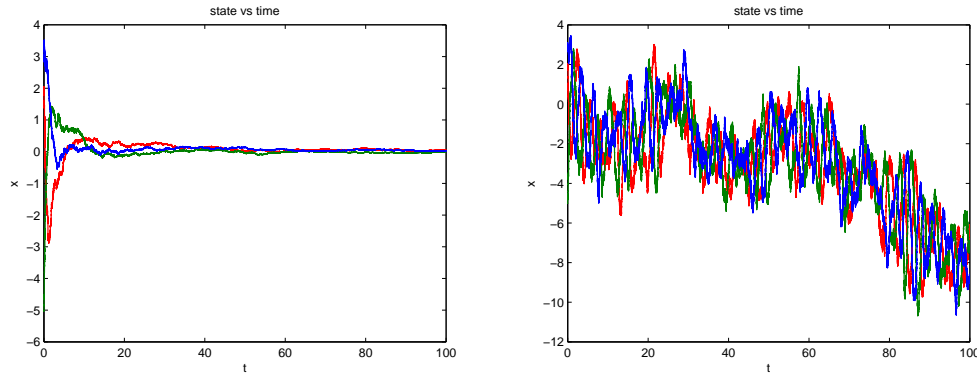

Figure 6.3 Simulation results for fixed topology \mathcal{G}_1 : the left figure shows results for $c(t) = 1/(t+1)$ and $\tau = 0.499$; the right figure shows results for $c(t) = 1$ and $\tau = 0.499$.

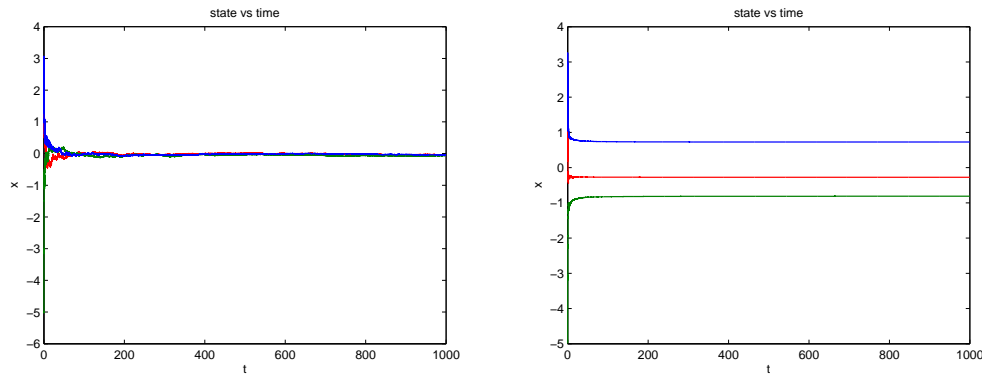

Figure 6.4 Simulation results for a Markovian switching topology among $\{\mathcal{G}_1, \mathcal{G}_2, \mathcal{G}_3\}$ driven by the generator $\Gamma = [-0.5 \ 0.2 \ 0.3; 0.4 \ -0.7 \ 0.3; 0.2 \ 0.55 \ -0.75]$: the left figure shows results for $c(t) = 1/(t+1)$ and $\tau = 0.111$; the right figure shows results for $c(t) = 1/(t+1)^2$ and $\tau = 0.111$.

they are also all strongly connected and balanced. The intensity of the measurement noises satisfies $\sigma_{ij} = 1$ for all $a_{ji} = 1$ ($i, j \in \mathcal{I}$). It can be calculated that $\lambda_2(\mathcal{L}_1) = 1.5$, $\lambda_2(\mathcal{L}_2) = \lambda_2(\mathcal{L}_3) = 1$, and $\|\mathcal{L}_1^2\| = 3$, $\|\mathcal{L}_2^2\| = \|\mathcal{L}_3^2\| = 9$. We simulate two different situations. First, we consider a fixed network topology given by \mathcal{G}_1 . According to Theorem 6.3.1, if the communication delays are less than $\lambda_2(\mathcal{L}_1)/\|\mathcal{L}_1^2\| = 0.5$, then the stochastic consensus protocol (6.1.6) will lead to mean square average-consensus for the network \mathcal{G}_1 . The initial states are chosen so that $\text{avg}(x(0)) = 0$. Average-consensus is confirmed by simulation as shown in Figure 6.3, where we choose $c(t) = 1/(t+1)$. It is also shown in this figure that if we choose $c(t) \equiv 1$, the noises cannot be attenuated, the states tend to

diverge from each other, and average-consensus is not reached. Second, we consider the situation where the network topologies are randomly switching among the three different configurations in $\{\mathcal{G}_1, \mathcal{G}_2, \mathcal{G}_3\}$ according to a continuous-time Markov chain. It follows from Theorem 6.3.3 that if the delays are less than

$$\frac{\min_{1 \leq i \leq 3} \lambda_2(\mathcal{L}_i)}{\max_{1 \leq i \leq 3} \|\mathcal{L}_i^2\|} = \frac{1}{9} = 0.1111,$$

then mean square average-consensus is reached. This is confirmed by simulation as shown in Figure 6.4, where we choose $c(t) = 1/(t + 1)$. It is also shown in this figure that if we choose $c(t) = 1/(t + 1)^2$, while the noises seem to be over attenuated, the states are settled at different values, and again consensus is not reached. Therefore, condition (6.1.7) on the function $c(t)$ plays a critical role in both attenuating the noise and achieving consensus.

6.5 Summary

We have investigated the average-consensus problem of networked multi-agents systems subject to measurement noises. A time-varying consensus protocol that takes into account both the measurement noises and general time-varying communication delays has been proposed. We have considered general networks with fixed topology, with arbitrary deterministic switching topology, and with Markovian switching topology. For each of these three cases, we have obtained sufficient conditions under which the proposed consensus protocol leads to mean square average-consensus. The sufficient conditions provide explicit delay upper bounds guaranteeing mean square average-consensus in terms of the graph Laplacians. We conclude this chapter by pointing some possible future research.

First, although both moment and almost sure average-consensus are formulated, this chapter focuses only on the mean square average-consensus. For future research, it would be interesting to propose consensus protocols to reach both general p th moment consensus and almost sure consensus.

Moreover, while characterizing exact delay bounds for stability of general linear time-delay systems remain challenging issues, obtaining optimal delay upper bounds for consensus are of practical importance. In [148], the exact delay bound for average-consensus is obtained for a fixed digraph network with a single constant delay, and in [15], exact delay bounds for average consensus are obtained for a fixed undirected network with a single time-varying delay or multiple constant delays. It would be interesting to know if these

bounds are still optimal under the measurement noises considered in this chapter. If so, one might be able to obtain necessary and sufficient conditions for mean square consensus despite both measurement noises and communication delays following the treatment in [127] for networked systems without communication time-delays.

Finally, when considering switching topology network, it is possible that some modes of the network fail to have a strongly connected and/or balanced network. These modes may be characterized as unstable modes and it would be interesting to investigate if the ideas from stability analysis of switched nonlinear systems with both stable and unstable subsystems in Section 2.4 can be applied here to investigate consensus problems under such situations.

C H A P T E R

7

Dynamics of Neural Networks

A neural network (or artificial neural network) is a mathematical or computational model inspired by the structural and functional aspects of the vast network of neurons in the human brain. A neural network processes information and performs computing tasks by connecting a large number of simple computing units, called (artificial) neurons.

As pointed out in [65], a neural network model can be regarded as a class of nonlinear signal-flow graphs. Each neuron takes weighted inputs from other connected neurons and produces an output through an activation function (often nonlinear). Therefore, neural networks are in fact a class of nonlinear dynamical systems due to the nonlinearity of activations. On the other hand, the computation developed using neural networks is essentially a self-adaptive distributed method based on a certain learning algorithm. The key point for the success of such an algorithm depends on whether or not the states of neurons converge to a given equilibrium. In this sense, the study of dynamics of neural networks is important for the desired applications. Most of the previous results on dynamics of neural networks have been focused on neural networks with Lipschitz continuous neuron activations.

The original work in [51] (see also [131]) has stimulated some interesting recent work (e.g., [51], [50], [49], [131], [132], [133], [149], [180], [177], [202]) on global stability of the equilibrium for neural networks with *discontinuous* neuron activations, which is an ideal model for the case in which the gain of the neuron amplifiers is very high [51], and frequently encountered in many applications (see, e.g., [72], [71], [125]). In practice, *time-delays* are inevitable in the applications of neural networks due to the finite switching

speed of amplifiers and communication time ([37], [141]). Interesting results have been published on delayed neural networks with discontinuous neuron activations ([50], [132], [133], [180], [177], [202]). In the seminal work [50], the authors investigated a class of delayed neuron networks with an arbitrary constant delay and discontinuous activations. Sufficient conditions for global exponential stability and global convergence in finite time of the delayed neural networks are given in terms of M-matrix conditions. In [132], dynamical behavior of delayed neural networks with discontinuous neuron activations are investigated. Under an easy-to-check assumption in terms of linear matrix inequalities, the authors derived global existence of solutions (viability), existence of equilibrium point, and global asymptotic stability of the delayed neural networks. In [180], the authors investigated dynamical behavior of the delayed Hopfield neural networks, where the neuron activation functions are assumed to be discontinuous and non-monotonic. In [177] and [202], taking the uncertainties into account, the authors investigated the robust stability of delayed neural networks with discontinuous neuron activations.

However, almost all of the above mentioned results deal with only a single constant time-delay. As pointed out in [50], it would be interesting to investigate discontinuous neural networks with more general delays, such as time-varying or distributed ones usually considered in neural networks with Lipschitz continuous neuron activations (see, e.g., [25], [26], [27], [82], [201]). One of the particular difficulties brought by time-varying and distributed delays, in the case where the activation functions are discontinuous, is that the step-by-step construction of local solutions to the discontinuous equations with delays as shown in [50] is no longer valid. In recent work [133], the authors not only investigated almost periodic dynamics of a general class of neural networks described by delayed integro-differential equations, they also showed that, by constructing a sequence of solutions to delayed dynamical systems with high-slope activations, one can obtain a solution in the sense of Filippov to discontinuous equations with general distributed delays.

Inspired by the approach in [133], we find that the difficulty of the existence of solutions for neural networks with discontinuous activations and general mixed time-delays can be overcome, which enables us to further investigate global stability of delayed neural networks with discontinuous neuron activations and mixed time-varying delays and distributed delays. We then investigate global stability and convergence of this general discontinuous delayed neural network model. Two sets of sufficient conditions are established, one in terms of linear matrix inequalities (LMIs) and the other in terms of M-matrix type conditions.

These results extend previous work on global stability of delayed neural networks with Lipschitz continuous neuron activations, and neural networks with discontinuous neuron activations and only constant delays. The study of this applied neural network model can also be regarded as applications of hybrid systems, since hybrid systems are often modeled with a combination of differential inclusions and difference inclusions as proposed in [55].

The structure of this chapter is outlined as follows. Section 7.1 discusses the neural network model studied in this chapter and presents some preliminaries. Section 7.2 present the main results on global stability and convergence, in which Section 7.2.1 provides sufficient conditions in terms of linear matrix inequalities and Section 7.2.2 gives M-matrix type conditions. Section 7.4 gives two examples to demonstrate the main results. Section 7.5 provides concluding remarks and possible topics for future work.

7.1 Neural Network Model and Preliminaries

Consider a class of neural networks described by the system of differential equations

$$\begin{aligned} \frac{dx_i(t)}{dt} = & -d_i x_i(t) + \sum_{j=1}^n a_{ij} g_j(x_j(t)) + \sum_{j=1}^n b_{ij} g_j(x_j(t - \tau_{ij}(t))) \\ & + \sum_{j=1}^n c_{ij} \int_0^\infty g_j(x_j(t-s)) p_{ij}(s) ds + I_i, \quad i = 1, \dots, n, \quad t \geq 0, \end{aligned} \quad (7.1.1)$$

where x_i is the state variable of the i th neuron; $d_i > 0$ are the self-inhibition of the i th neuron; a_{ij} are the connection strength of the j th neuron on the i th neuron; b_{ij} and c_{ij} are the delayed feedback of the j th neuron on the i th neuron, through time-varying delay and distributed delay, respectively; $\tau_{ij}(t)$ are the time-varying delays; $p_{ij}(s)$ are the probability kernels of the distributed delays; $g_i : \mathcal{R} \rightarrow \mathcal{R}$ represents the neuron input-output activation of the i th neuron; and I_i denotes the external input to the i th neuron.

Throughout this chapter, we suppose that the activation functions g_i belong to the **class** \mathcal{G} , where \mathcal{G} denotes the class of functions from \mathcal{R} to \mathcal{R} which are monotonically nondecreasing and have at most a finite number of jump discontinuities in every bounded interval.

Moreover, we assume, throughout this chapter, that the **time-varying delays** and the **distributed delays** satisfy that, for $i, j = 1, \dots, n$, $\tau_{ij}(t)$ are continuous functions from $[0, \infty)$ to $[0, \infty)$ such that $0 \leq \tau_{ij}(t) \leq r_{ij} < \infty$, where r_{ij} are some non-negative constants, and each kernel function $p_{ij}(\cdot)$ is a measurable function from $[0, \infty)$ to $[0, \infty)$ with $\int_0^\infty p_{ij}(s) ds = 1$.

Before we introduce the concept of **Filippov solution** for system (7.1.1), we present some preliminary definitions for later use. Given a set $E \subset \mathcal{R}^n$. Then $x \rightarrow F(x)$ is called a **set valued map** from $E \rightarrow \mathcal{R}^n$, if for each point $x \in E$, there exists a nonempty set $F(x) \subset \mathcal{R}^n$. A set-valued map F with nonempty values is said to be **upper semicontinuous** at $x_0 \in E$, if for any open set N containing $F(x_0)$, there exists a neighborhood M of x_0 such that $F(M) \subset N$. The map $F(x)$ is said to have a **closed (convex, compact) image** if for each $x \in E$, $F(x)$ is closed (convex, compact). We define $\text{Graph}(F(E)) = \{(x, y) \mid x \in E, y \in F(x)\}$. Let $x \in \mathcal{R}^n$ be a vector and $A \in \mathcal{R}^{n \times n}$ be a matrix. We use $\|x\|$ to denote the Euclidean norm of x and $\|A\|$ to denote the matrix norm induced by the Euclidean norm.

Now, for $x \in \mathcal{R}^n$ and $g_i \in \mathcal{G}$, $i = 1, \dots, n$, we denote by $g(x) = (g_1(x_1), \dots, g_n(x_n))$, a diagonal mapping, and denote

$$K[g(x)] = (K[g_1(x_1)], \dots, K[g_n(x_n)]),$$

where $K[g_i(x_i)] = [g_i(x_i^-), g_i(x_i^+)]$, with $g_i(x_i^-) = \lim_{x \rightarrow x_i^-} g_i(x)$ and $g_i(x_i^+) = \lim_{x \rightarrow x_i^+} g_i(x)$.

Definition 7.1.1 (Filippov Solutions) Suppose that $\phi = (\phi_1, \dots, \phi_n)^T$ is a continuous function from $(-\infty, 0]$ to \mathcal{R}^n and ψ is a measurable function $\psi = (\psi_1, \dots, \psi_n)^T$ from $(-\infty, 0]$ to \mathcal{R}^n such that $\psi(s) \in K[g(\phi(s))]$ almost everywhere (a.e.) on $(-\infty, 0]$. We say that $x(t) = (x_1(t), \dots, x_n(t))^T$, a function from $(-\infty, T]$ to \mathcal{R}^n , is a **solution** to the initial value problem for (7.1.1) on $[0, T]$, with initial data (ϕ, ψ) , if

- (i) x is continuous on $(-\infty, T]$ and absolutely continuous on $[0, T]$;
- (ii) there exists a measurable function $\gamma = (\gamma_1, \dots, \gamma_n)^T$ from $(-\infty, T]$ to \mathcal{R}^n such that $\gamma(s) \in K[g(x(s))]$ a.e. on $[0, T]$ and

$$\begin{aligned} \frac{dx_i(t)}{dt} = & -d_i x_i(t) + \sum_{j=1}^n a_{ij} \gamma_j(t) + \sum_{j=1}^n b_{ij} \gamma_j(t - \tau_{ij}(t)) \\ & + \sum_{j=1}^n c_{ij} \int_0^\infty \gamma_j(t-s) p_{ij}(s) ds + I_i, \end{aligned} \quad (7.1.2)$$

holds a.e. on $[0, T]$, for all $i = 1, \dots, n$;

- (iii) $x(s) = \phi(s)$ and $\gamma(s) = \psi(s)$ hold for all $s \in (-\infty, 0]$.

Any function as in (7.1.2) is called an **output** associated with the solution x . □

Throughout this chapter, the initial functions ϕ and ψ (as described in Definition 7.1.1) satisfy the following: ϕ is a bounded continuous function from $(-\infty, 0]$ to \mathcal{R}^n and ψ is an essentially bounded measurable function from $(-\infty, 0]$ to \mathcal{R}^n such that $\psi(s) \in K[g(\phi(s))]$ a.e. on $(-\infty, 0]$. The norms of ϕ and ψ are given by the supremum and essential supremum norm, respectively.

7.1.1 A Lemma on Existence of Equilibrium Point

Definition 7.1.2 (Equilibrium Point) We say that a vector $\xi \in \mathcal{R}^n$ is an *equilibrium point* of (7.1.1) if there exists $\eta \in K[g(\xi)]$ such that

$$0 = -D\xi + (A + B + C)\eta + I,$$

where $D = \text{diag}\{d_1, \dots, d_n\}$, $A = (a_{ij})_{i,j=1}^n$, $B = (b_{ij})_{i,j=1}^n$, $C = (c_{ij})_{i,j=1}^n$, and $I = (I_1, \dots, I_n)^T$. The vector η is called an *output equilibrium point* corresponding to the equilibrium point ξ . \square

Remark 7.1.1 If there exists an equilibrium point of (7.1.1), without loss of generality, we can assume that 0 is an equilibrium point of system (7.1.1) with $I = 0$, and 0 is a corresponding output equilibrium point, i.e., $0 \in K[g(0)]$. Actually, if ξ is an equilibrium point of (7.1.1) and η is the corresponding output equilibrium point, we can always define $y(t) = x(t) - \xi$ and $\mu(t) = \gamma(t) - \eta$, and investigate the resulting system about $y(t)$. \square

The following lemma, taken from [131], provides a useful sufficient condition to check for the existence of an equilibrium point for system (7.1.1).

Lemma 7.1.1 (Existence of Equilibrium, Theorem 2 in [131]) *If $-S$ is a Lyapunov diagonally stable matrix, i.e., there exists a positive definite diagonal matrix P such that $-PS - S^T P$ is positive definite, then there exist $\xi \in \mathcal{R}^n$ and $\eta \in K[g(\xi)]$ such that*

$$0 = -D\xi + S\eta + I,$$

where g , D , and I are the same as in system (7.1.1).

This important lemma is proved in [131] using an equilibrium theorem from [3]. For the sake of completeness, we present here a different and somewhat more direct proof of Lemma 7.1.1 based on a nonlinear alternative for set-valued maps, taken from [56].

Lemma 7.1.2 (Nonlinear Alternative, Theorem 8.5 in [56]) *Let C be a convex set in a normed linear space, and let $U \subset C$ be open with $0 \in U$. Let $\mathcal{K}(\bar{U}, 2^C)$ denote the set of nonempty compact convex upper semicontinuous set-valued maps from the closure of U to C . Then each $F \in \mathcal{K}(\bar{U}, 2^C)$ has at least one of the following properties:*

- (a) *F has a fixed point in \bar{U} , i.e., there exists some $x_0 \in \bar{U}$ such that $x_0 \in F(x_0)$;*
- (b) *there exists $x \in \partial U$ (the boundary of U) and $\lambda \in (0, 1)$ such that $x \in \lambda F(x)$.*

Now we are ready to prove Lemma 7.1.1.

Proof (Lemma 7.1.1). It is easy to see that the conclusion of Lemma 7.1.1 is equivalent to the statement that there exists $\xi \in \mathcal{R}^n$ such that

$$\xi \in D^{-1} \{SK[g(\xi)] + I\}, \quad (7.1.3)$$

i.e., the set-valued map $G(x)$, defined by $G(x) = D^{-1} \{SK[g(x)] + I\}$ for $x \in \mathcal{R}^n$, has a fixed point. Consider two cases:

- (i) Suppose that G , as a set-valued map from \mathcal{R}^n to \mathcal{R}^n , is bounded. Therefore, there exists an open ball $B(0, r)$, centered at 0 and with radius $r > 0$, such that $G(x) \subset B(0, r)$ for all $x \in \mathcal{R}^n$. We let $U = B(0, r)$. It is clear that the second alternative in Lemma 7.1.2 does not hold for G and U , and, therefore, $G(x)$ has a fixed point by Lemma 7.1.2.
- (ii) Suppose that G is unbounded. It follows that g must be unbounded. Since g_i are class \mathcal{G} functions, there must exist $i \in \{1, \dots, n\}$ such that

$$\text{either } \lim_{s \rightarrow \infty} g_i(s) = \infty \quad \text{or} \quad \lim_{s \rightarrow \infty} g_i(s) = -\infty.$$

Without loss of generality, we shall assume that $\lim_{s \rightarrow \infty} g_i(s) = \infty$. Let

$$a = \lambda_{\min}(-PS - S^T P) > 0, \quad b = \frac{2 \|PI\|^2}{a} > 0,$$

where $\lambda_{\min}(\cdot)$ represents the minimum real eigenvalue of a matrix. Without loss of generality, we can assume $0 \in K[g(0)]$. Actually, if this is not the case, we can define $\tilde{g} = g - \tilde{\eta}$, where $\tilde{\eta} \in g(0)$, and $\tilde{I} = I + S\tilde{\eta}$. Then, we have $0 \in K[\tilde{g}(0)]$, and \tilde{g} still satisfies $\lim_{s \rightarrow \infty} g_i(s) = \infty$ and $G(x) = D^{-1} \{SK[\tilde{g}(x)] + \tilde{I}\}$. Now, since $0 \in K[g(0)]$ and g_i is in class \mathcal{G} , it follows that

$$\eta^T P D x \geq 0, \quad \forall x \in \mathcal{R}^n, \quad \eta \in K[g(x)]. \quad (7.1.4)$$

Since $\lim_{s \rightarrow \infty} g_i(s) = \infty$, it follows that there exists $c > 0$ such that $x_i \geq c$ implies $g_i(x_i^-) > \sqrt{\frac{2b}{a}}$. Let $U = \{x \in \mathcal{R}^n : x_i < c\}$. We proceed to show that, with this choice of U , the second alternative of Lemma 7.1.2 does not hold for G . We show this by contradiction. Suppose there exists $x \in \partial U$, i.e., $x_i = c$, and $\lambda \in (0, 1)$ such that $x \in \lambda G(x)$, i.e., there exists $\eta \in K[g(x)]$ such that

$$0 = -Dx + \lambda(S\eta + I). \quad (7.1.5)$$

It follows from (7.1.4) and (7.1.5) that

$$\begin{aligned} 0 &= 2\eta P[-Dx + \lambda(S\eta + I)] \\ &\leq -\lambda\eta^T(-PS - S^T P)\eta + 2\lambda\eta^T P I \\ &\leq -a\lambda \|\eta\|^2 + \frac{a}{2}\lambda \|\eta\|^2 + \frac{2}{a}\lambda \|PI\|^2 \\ &\leq \lambda \left(-\frac{a}{2} |\eta_i|^2 + b \right), \end{aligned} \quad (7.1.6)$$

where $\eta_i \in [g_i(x_i^-), g_i(x_i^+)]$. By the choice of c , it follows that $-\frac{a}{2} |\eta_i|^2 + b < 0$, which contradicts (7.1.6). Therefore, $G(x)$ has a fixed point by Lemma 7.1.2.

The proof is now complete. \square

As an immediate consequence of Lemma 7.1.1, it is seen that, if $-(A + B + C)$ is Lyapunov diagonally stable, then there exists an equilibrium point for system (7.1.1).

7.2 Global Stability and Convergence

In this section, we present the main results of this chapter, which include two sets of sufficient conditions for the global stability and convergence of both the state and the output of system (7.1.1), in terms of linear matrix inequalities in Section 7.2.1, and M-matrix type conditions in Section 7.2.2.

7.2.1 Sufficient Conditions by LMIs

We propose the following linear matrix inequality based on the coefficient matrices A , B , and C of (7.1.1):

$$Z = \begin{bmatrix} -PA - A^T P - Q - R & -PB & -PC \\ -B^T P & (1 - \rho)Q & 0 \\ -C^T P & 0 & R \end{bmatrix} > 0, \quad (7.2.1)$$

where ρ is a non-negative constant, P is a positive diagonal matrix, and Q and R are positive definite symmetric matrices.

The main results of this subsection state that, if the linear matrix inequality (7.2.1) holds, then there exists an equilibrium point of (7.1.1) and the equilibrium point is exponentially stable.

Theorem 7.2.1 *If (7.2.1) is satisfied, then system (7.1.1) has an equilibrium point.*

Proof. The matrix inequality (7.2.1) implies that

$$\begin{bmatrix} -PA - A^T P - Q - R & -PB & -PC \\ -B^T P & Q & 0 \\ -C^T P & 0 & R \end{bmatrix} > 0,$$

which, by Schur's complement (see, e.g., [19]), is equivalent to

$$\begin{aligned} -PA - A^T P &> [PB \quad PC] \begin{bmatrix} Q^{-1} & 0 \\ 0 & R^{-1} \end{bmatrix} \begin{bmatrix} B^T P \\ C^T P \end{bmatrix} + Q + R, \\ &= PBQ^{-1}B^T P + Q + PCR^{-1}C^T P + R. \end{aligned}$$

Since

$$[Q^{-\frac{1}{2}}B^T P - Q^{\frac{1}{2}}]^T [Q^{-\frac{1}{2}}B^T P - Q^{\frac{1}{2}}] \geq 0,$$

and

$$[R^{-\frac{1}{2}}B^T P - R^{\frac{1}{2}}]^T [R^{-\frac{1}{2}}B^T P - R^{\frac{1}{2}}] \geq 0,$$

we have

$$PBQ^{-1}B^T P + Q \geq PB + B^T P,$$

and

$$PCR^{-1}C^T P + R \geq PC + C^T P.$$

Therefore,

$$-P(A + B + C) - (A + B + C)^T P > 0,$$

i.e., $-(A + B + C)$ is Lyapunov diagonally stable. It follows from Lemma 7.1.1 that there exists an equilibrium point for system (7.1.1). Theorem 7.2.1 is proved. \square

Note that, in view of Theorem 7.2.1 and Remark 7.1.1, we may suppose that $I = 0$ and $0 \in K[g(0)]$, by using a translation $y(t) = x(t) - \xi$ and $\mu(t) = \gamma(t) - \eta$, if necessary.

Moreover, in order to write system (7.1.1) in matrix form and derive stability conditions in terms of linear matrix inequalities, we further assume that $\tau_{ij}(t) \equiv \tau(t)$ and $p_{ij}(t) \equiv p(t)$, for $i, j = 1, \dots, n$, where $0 \leq \tau(t) \leq r < \infty$, $\tau'(t) \leq \rho < 1$, and $\int_0^\infty p(s)ds = 1$, with both r and ρ as non-negative constants with ρ as given by (7.2.1). Therefore, a solution $x(t)$ to system (7.1.1) in the sense of Definition 7.1.1 satisfies

$$x'(t) = -Dx(t) + A\gamma(t) + B\gamma(t - \tau(t)) + C \int_0^\infty \gamma(t - s)p(s)ds, \quad (7.2.2)$$

where $\gamma(t)$ is an output associated with x as in Definition 7.1.1.

We have the following result on the global stability of system (7.1.1).

Theorem 7.2.2 *If (7.2.1) is satisfied, then the following statements are true.*

- (i) *There exists a solution to system (7.1.1) on $[0, \infty)$ for any initial data.*
- (ii) *There exist a unique equilibrium point ξ and a unique corresponding output equilibrium point η of (7.1.1).*
- (iii) *Let $x(t)$ be a solution to system (7.1.1) on $[0, \infty)$ and $\gamma(t)$ be an associated output. There exist positive constants $M > 0$ and $c > 0$ such that*

$$\|x(t) - \xi\| \leq Me^{-ct}, \quad t \geq 0,$$

i.e., the equilibrium point ξ is globally exponentially stable, and $\gamma(t)$ converge to the output equilibrium point η in measure, i.e., $\lambda - \lim_{t \rightarrow \infty} \gamma(t) = \eta$, where λ is the Lebesgue measure.

The following lemma on linear matrix inequalities is used in the proof of Theorem 7.2.2.

Lemma 7.2.1 *If the matrix inequality (7.2.1) holds, then there exist a positive constant $\varepsilon < \min_{i \in \{1, 2, \dots, n\}} d_i$, a positive diagonal matrix \hat{P} , and positive definite symmetric matrices \hat{Q} and \hat{R} such that*

$$H = \begin{bmatrix} -2D + \varepsilon E_n & A & B & C \\ A^T & \Xi & \hat{P}B & \hat{P}C \\ B^T & B^T \hat{P} & -(1 - \rho)\hat{Q} & 0 \\ C^T & C^T \hat{P} & 0 & -\hat{R} \end{bmatrix} < 0, \quad (7.2.3)$$

where $\Xi = \hat{P}A + A^T\hat{P} + e^{\varepsilon r}\hat{Q} + e^{\varepsilon r}\hat{R} + \varepsilon E_n$ and E_n is the n -dimensional identity matrix.

Proof. Choose $x, y, z, w \in \mathcal{R}^n$ and $\hat{P} = \theta P, \hat{Q} = \theta Q, \hat{R} = \theta R$, where P, Q , and R are from the matrix inequality (7.2.1) and $\theta > 0$, together with $\varepsilon > 0$ in (7.2.3), is to be determined later in the proof. We have

$$\begin{aligned} & [x^T \ y^T \ z^T \ w^T]H[x^T \ y^T \ z^T \ w^T]^T \\ &= -2x^T Dx + \varepsilon x^T x + 2x^T Ay + 2x^T Bz + 2x^T Cw \\ &\quad + \theta y^T (PA + A^T P)y + \theta e^{\varepsilon r} y^T Qy + \theta e^{\varepsilon r} y^T Ry \\ &\quad + \varepsilon y^T y + 2\theta y^T PBz + 2\theta y^T PCw - (1 - \rho)\theta z^T Qz - \theta w^T R w \\ &= -\theta [y^T \ z^T \ w^T]Z[y^T \ z^T \ w^T]^T \\ &\quad - 2x^T Dx + \varepsilon x^T x + 2x^T Ay + 2x^T Bz + 2x^T Cw \\ &\quad + \theta(e^{\varepsilon r} - 1)y^T Qy + \theta(e^{\varepsilon r} - 1)y^T Ry + \varepsilon y^T y, \end{aligned}$$

where Z is from (7.2.1). Let $\lambda = \lambda_{\min}(Z)$ and $d = \min_{i \in \{1, 2, \dots, n\}} d_i$, the above equation gives

$$\begin{aligned} & [x^T \ y^T \ z^T \ w^T]H[x^T \ y^T \ z^T \ w^T]^T \\ & \leq -\theta\lambda(y^T y + z^T z + w^T w) - (2d - 4\varepsilon)x^T x \\ & \quad + \left\{ \theta(e^{\varepsilon r} - 1)\|Q\| + \theta(e^{\varepsilon r} - 1)\|R\| + \varepsilon + \varepsilon^{-1}\|A\|^2 \right\} y^T y \\ & \quad + \varepsilon^{-1}\|B\|^2 z^T z + \varepsilon^{-1}\|C\|^2 w^T w. \end{aligned} \tag{7.2.4}$$

Now choose the positive constant $\varepsilon < d$ (as required by Lemma 7.2.1) sufficiently small such that

$$2d - 4\varepsilon > 0, \quad (e^{\varepsilon r} - 1)\|Q\| < \lambda, \quad (e^{\varepsilon r} - 1)\|R\| < \lambda.$$

Fix this choice of $\varepsilon > 0$ and let $\theta > 0$ be sufficiently large such that

$$\theta\lambda > \theta(e^{\varepsilon r} - 1)\|Q\| + \theta(e^{\varepsilon r} - 1)\|R\| + \varepsilon + \varepsilon^{-1}\|A\|^2,$$

and

$$\theta\lambda > \varepsilon^{-1}\|B\|^2, \quad \theta\lambda > \varepsilon^{-1}\|C\|^2.$$

Then inequality (7.2.4) shows that H is negative definite. Lemma 7.2.1 is proved. \square

The following lemma generalizes a useful integral inequality from [57].

Lemma 7.2.2 *Let u be a measurable function defined on $[0, \infty)$ and R be a positive definite symmetric matrix. Suppose that $p : [0, \infty) \rightarrow [0, \infty)$ is measurable and $\int_0^\infty p(s)ds = 1$. We have*

$$\int_0^\infty u^T(s)Ru(s)p(s)ds \geq \left(\int_0^\infty u(s)p(s)ds \right)^T R \int_0^\infty u(s)p(s)ds.$$

Proof. Applying the Cauchy-Shwartz inequality, we have

$$\begin{aligned} \left(\int_0^\infty u(s)p(s)ds \right)^T R \int_0^\infty u(s)p(s)ds &= \left\| \int_0^\infty R^{\frac{1}{2}}u(s)\sqrt{p(s)}\sqrt{p(s)}ds \right\|^2 \\ &\leq \int_0^\infty \|R^{\frac{1}{2}}u(s)\sqrt{p(s)}\|^2 ds \int_0^\infty p(s)ds \\ &= \int_0^\infty u^T(s)Ru(s)p(s)ds. \end{aligned}$$

Lemma 7.2.2 is proved. \square

Now we are ready to present the proof of Theorem 7.2.2.

Proof (Theorem 7.2.2). The proof of part (i) is illustrated in Section 7.3. The existence of equilibrium point and output equilibrium point follows from Theorem 7.2.1 and the uniqueness follows from part (iii). It remains to show part (iii). Let $x(t)$ be a solution to (7.1.1) on $[0, \infty)$ and $\gamma(t)$ is an associated output. According to Remark 7.1.1 and the remark after Theorem 7.2.1, we can assume both $\xi = 0$, $\eta = 0$, and $x(t)$ obeys (7.2.2). Consider

$$\begin{aligned} V(t) &= e^{\varepsilon t}x^T(t)x(t) + 2 \sum_{i=1}^n e^{\varepsilon t}\hat{P}_i \int_0^{x_i(t)} g_i(s)ds + \int_{t-\tau(t)}^t \gamma^T(s)\hat{Q}\gamma(s)e^{\varepsilon(s+r)}ds \\ &\quad + \int_0^\infty \int_{t-s}^t \gamma^T(\theta)\hat{R}\gamma(\theta)p(s)d\theta ds, \quad t \geq 0, \end{aligned}$$

where ε , \hat{P} , \hat{Q} , and \hat{R} are given by Lemma 7.2.1. Differentiating $V(t)$ according to (7.2.2) and the generalized chain rule (see [38]; see also [51] or [131] for details), we obtain

$$\begin{aligned} \frac{dV(t)}{dt} &= \varepsilon e^{\varepsilon t}x^T(t)x(t) + 2e^{\varepsilon t}x^T(t) \left[-Dx(t) + A\gamma(t) \right. \\ &\quad \left. + B\gamma(t - \tau(t)) + C \int_0^\infty \gamma(t - s)p(s)ds \right] \\ &\quad + 2e^{\varepsilon t}\gamma(t)\hat{P} \left[-Dx(t) + A\gamma(t) \right] \end{aligned}$$

$$\begin{aligned}
& + B\gamma(t - \tau(t)) + C \int_0^\infty \gamma(t - s)p(s)ds \Big] \\
& + 2\varepsilon e^{\varepsilon t} \sum_i^n \hat{P}_i \int_0^{x_i(t)} g_i(s)ds + e^{\varepsilon(t+r)} \gamma^T(t) \hat{Q} \gamma(t) \\
& - e^{\varepsilon(t-\tau(t)+r)} (1 - \tau'(t)) \gamma^T(t - \tau(t)) \hat{Q} \gamma(t - \tau(t)) \\
& + e^{\varepsilon t} \int_0^\infty \gamma^T(t) \hat{R} \gamma(t) p(s)ds - e^{\varepsilon t} \int_0^\infty \gamma^T(t - s) \hat{R} \gamma(t - s) p(s)ds.
\end{aligned}$$

By $\varepsilon < \min_{i \in \{1, 2, \dots, n\}} d_i$, $0 \in K[g_i(0)]$, and the monotone property of g_i , we have

$$\varepsilon \int_0^{x_i(t)} g_i(s)ds \leq \varepsilon x_i(t) \gamma_i(t) \leq d_i x_i(t) \gamma_i(t).$$

Using $\tau'(t) \leq \rho < 1$ and Lemma 7.2.2, we have

$$\frac{dV(t)}{dt} \leq e^{\varepsilon t} z^T H z - \varepsilon \gamma^T(t) \gamma(t) \leq -\varepsilon \gamma^T(t) \gamma(t) \leq 0, \quad (7.2.5)$$

where H is given by Lemma 7.2.1 and

$$z = \begin{bmatrix} x^T(t) & \gamma^T(t) & \gamma^T(t - \tau(t)) & \int_0^\infty \gamma^T(t - s) p(s) ds \end{bmatrix}^T.$$

It follows that $V(t) \leq V(0)$ and

$$\|x(t)\| \leq \sqrt{V(t)} e^{-\frac{\varepsilon}{2}t} \leq \sqrt{V(0)} e^{-\frac{\varepsilon}{2}t}, \quad t \geq 0.$$

We proceed to show the convergence of output. From (7.2.5), we have

$$V(t) - V(0) \leq -\varepsilon \int_0^t \|\gamma(s)\|^2 ds.$$

Since $V(t) \geq 0$ for all $t \geq 0$, we have

$$\int_0^\infty \|\gamma(s)\|^2 ds \leq \frac{1}{\varepsilon} V(0).$$

For any $\varepsilon_0 > 0$, let $E_{\varepsilon_0} = \{t \in [0, \infty) : \|\gamma(t)\| \geq \varepsilon_0\}$. Then

$$\frac{V(0)}{\varepsilon} \geq \int_0^\infty \|\gamma(s)\|^2 ds \geq \int_{E_{\varepsilon_0}} \|\gamma(s)\|^2 ds \geq \varepsilon_0^2 \lambda(E_{\varepsilon_0}),$$

where $\lambda(\cdot)$ is the Lebesgue measure. It follows that $\lambda(E_{\varepsilon_0}) < \infty$. By Proposition 2 in [51], we have $\gamma(t)$ converges to 0 in measure, i.e., $\lambda - \lim_{t \rightarrow \infty} \gamma(t) = 0$. The proof is complete. \square

Remark 7.2.1 If there are no distributed delays (i.e., $C = 0$) and the time-varying delay reduces to a constant delay (i.e., $\tau(t) = \tau$ and $\rho = 0$), then it can be seen that Theorems 7.2.1 and 7.2.2 include some of the main results in [132] (i.e., Theorems 1, 4, and 5 there) as corollaries. \square

7.2.2 Sufficient Conditions by M-Matrix

The M-matrix type conditions allow us to deal with more general types of mixed delays, i.e., τ_{ij} and p_{ij} can be non-identical. We assume that there exist a positive constant $\alpha > 0$ and constants $\rho_{ij} \in [0, 1)$ such that

$$\int_0^\infty e^{\alpha s} p_{ij}(s) ds < \infty, \quad \tau'_{ij}(t) \leq \rho_{ij} < 1, \quad (7.2.6)$$

for all $i, j = 1, \dots, n$ and $t \geq 0$.

In order to propose some M-matrix type conditions on the coefficient matrices A, B , and C of (7.1.1), we first introduce the following notations. We define $\mathcal{M}(A) = (\hat{a}_{ij})_{i,j=1}^n$, where $\hat{a}_{ij} = |a_{ii}|$ for $i = j$ and $\hat{a}_{ij} = -|a_{ij}|$ for $i \neq j$, i.e., \mathcal{A} is the **comparison matrix** of A (see [73]). Let $|C|$ denote the matrix obtained by taking entrywise absolute values of the entries in C . Define $\hat{B} = (\hat{b}_{ij})_{i,j=1}^n$, where $\hat{b}_{ij} = \frac{|b_{ij}|}{1-\rho_{ij}}$.

Assumption 7.2.1 (M-Matrix Condition) The matrix $\Theta = \mathcal{M}(A) - \hat{B} - |C|$ is an **M-matrix**, i.e., all successive principal minors of Θ are positive, and $a_{ii} < 0$ for $i = 1, \dots, n$. \square

The main results of this subsection state that, if the above condition holds, then there exists an equilibrium point of (7.1.1) and the equilibrium point is exponentially stable.

According to the theory of M-matrices (see [73]), Assumption 7.2.1 is equivalent to that there exists a vector $\beta = (\beta_1, \dots, \beta_n) > 0$ such that, for $i = 1, \dots, n$, we have

$$\beta_i a_{ii} + \sum_{\substack{j=1 \\ j \neq i}}^n \beta_j |a_{ji}| + \sum_{j=1}^n \frac{\beta_j |b_{ji}|}{1-\rho_{ij}} + \sum_{j=1}^n \beta_j |c_{ji}| < 0. \quad (7.2.7)$$

In view of (7.2.6) and (7.2.7), if Assumption 7.2.1 holds, we can find a constant $\delta \in (0, \min_{i \in \{1, 2, \dots, n\}} d_i)$ sufficiently small such that, for $i = 1, \dots, n$, we have

$$\beta_i a_{ii} + \delta + \sum_{\substack{j=1 \\ j \neq i}}^n \beta_j |a_{ji}| + \sum_{j=1}^n \beta_j |b_{ji}| \frac{e^{\delta r_{ij}}}{1-\rho_{ij}} + \sum_{j=1}^n \beta_j |c_{ji}| \int_0^\infty e^{\delta s} p_{ji}(s) ds < 0. \quad (7.2.8)$$

This inequality plays an important role in the proof of the following results.

Theorem 7.2.3 *If Assumption 7.2.1 is satisfied, then system (7.1.1) has an equilibrium point.*

Proof. Since $0 < 1 - \rho_{ij} \leq 1$, inequality (7.2.7) implies that

$$\beta_i a_{ii} + \sum_{\substack{j=1 \\ j \neq i}}^n \beta_j |a_{ji}| + \sum_{j=1}^n \beta_j (|b_{ji}| + |c_{ji}|) < 0, \quad i = 1, \dots, n,$$

which, by $a_{ii} < 0$, implies that

$$\begin{aligned} \beta_i |a_{ii} + b_{ii} + c_{ii}| &\geq \beta_i (-a_{ii} - |b_{ii}| - |c_{ii}|) \\ &> \sum_{\substack{j=1 \\ j \neq i}}^n \beta_j (|a_{ji}| + |b_{ji}| + |c_{ji}|) \\ &\geq \sum_{\substack{j=1 \\ j \neq i}}^n \beta_j |a_{ji} + b_{ji} + c_{ji}|, \quad i = 1, \dots, n. \end{aligned}$$

This shows that $-(A + B + C)$ is an H -matrix, i.e., the comparison matrix of $-(A + B + C)$ is an M -matrix. Since the diagonal entries of $-(A + B + C)$, given by $-a_{ii} - b_{ii} - c_{ii}$, are positive, we can conclude that $-(A + B + C)$ is Lyapunov diagonally stable [73]. It follows from Lemma 7.1.1 that there exists an equilibrium point for system (7.1.1). Theorem 7.2.3 is proved. \square

Theorem 7.2.4 *If Assumptions 7.2.1 is satisfied, then the same statements as in Theorem 7.2.2 hold.*

Proof. Proof of part (i) is illustrated in Section 7.3. The existence of equilibrium point and output equilibrium point follows from Theorem 7.2.3 and the uniqueness follows from part (iii). It remains to show part (iii). Let $x(t)$ be a solution to (7.1.1) on $[0, \infty)$ and $\gamma(t)$ is an associated output. Same as before, we can assume both $\xi = 0, \eta = 0$, and $x(t)$ obeys (7.1.1) with $I = 0$. Consider

$$\begin{aligned} V(t) &= \sum_{i=1}^n \beta_i |x_i(t)| e^{\delta t} + \sum_{i,j=1}^n \frac{\beta_i |b_{ij}|}{1 - \rho_{ij}} \int_{t-\tau_{ij}(t)}^t |\gamma_j(s)| e^{\delta(s+r_{ij})} ds \\ &\quad + \sum_{i,j=1}^n \beta_i |c_{ij}| \int_0^\infty \int_{t-s}^t |\gamma_j(\theta)| e^{\delta(s+\theta)} d\theta ds, \quad t \geq 0, \end{aligned}$$

where β and δ are from (7.2.8). Differentiating $V(t)$ gives

$$\begin{aligned}
\frac{dV(t)}{dt} &= \sum_{i=1}^n \delta \beta_i |x_i(t)| e^{\delta t} + \sum_{i=1}^n \beta_i e^{\delta t} \text{sign}(x_i(t)) \left(-d_i x_i(t) \right. \\
&\quad \left. + \sum_{j=1}^n a_{ij} \gamma_j(t) + \sum_{j=1}^n b_{ij} g_j(x_j(t - \tau_{ij}(t))) + \sum_{j=1}^n c_{ij} \int_0^\infty g_j(x_j(t-s)) p_{ij}(s) ds \right) \\
&\quad + \sum_{i,j=1}^n \frac{\beta_i |b_{ij}| e^{\delta t}}{1 - \rho_{ij}} \left[|\gamma_j(t)| e^{\delta r_{ij}} - (1 - \tau'(t)) |\gamma_j(t - \tau_{ij}(t))| \right] \\
&\quad + \sum_{i,j=1}^n \beta_j |c_{ij}| e^{\delta t} \int_0^\infty [|\gamma_j(t)| e^s - |\gamma_j(t-s)|] ds \\
&\leq \sum_{i=1}^n \beta_i |x_i(t)| e^{\delta t} (-d_i + \delta) + \sum_{i=1}^n e^{\delta t} |\gamma_i(t)| \left(\beta_i a_{ii} \right. \\
&\quad \left. + \sum_{\substack{j=1 \\ j \neq i}}^n \beta_j |a_{ji}| + \sum_{j=1}^n \beta_j |b_{ji}| \frac{e^{\delta r_{ij}}}{1 - \rho_{ij}} + \sum_{j=1}^n \beta_j |c_{ii}| \int_0^\infty e^{\delta s} p_{ji}(s) ds \right).
\end{aligned}$$

By the inequality in Remark 7.2.8, it follows that

$$\frac{dV(t)}{dt} \leq -\delta \sum_{i=1}^n |\gamma_i(t)| \leq 0. \tag{7.2.9}$$

Therefore, $V(t) \leq V(0)$ and

$$\sum_{i=1}^n \beta_i |x_i(t)| \leq V(0) e^{-\delta t}, \quad t \geq 0.$$

Since $\beta > 0$ and all norms in \mathcal{R}^n are equivalent, there exists a positive constant $c_1 > 0$ such that

$$\|x(t)\| \leq c_1 V(0) e^{-\delta t}, \quad t \geq 0.$$

We proceed to show the convergence of output. From (7.2.9) and that all norms in \mathcal{R}^n are equivalent, we can find a constant c_2 such that

$$V(t) - V(0) \leq -c_2 \int_0^t \|\gamma(s)\| ds.$$

The rest of the proof is similar to that of Theorem 7.2.2. \square

Remark 7.2.2 If there are no distributed delays (i.e., $C = 0$) and the time-varying delays reduce to a constant delay (i.e., $\tau_{ij}(t) = \tau$ and $\rho_{ij} = 0$), then Assumption 7.2.1 becomes that $\Theta = \mathcal{M}(A) - |B|$ is an M-matrix and $a_{ii} < 0$, $i = 1, \dots, n$, which is exactly the same assumption as proposed in [50] for global convergence of (constantly) delayed neural networks with discontinuous neuron activations. Therefore, the convergence results in [50] can be regarded as corollaries of Theorems 7.2.3 and 7.2.4. \square

7.3 Local Existence of Solutions

In this section, we provide a sketch of proof for part (i) of Theorem 7.2.2 and Theorem 7.2.4. Following the idea of [58], it is shown in both [132] and [133] that, by constructing a sequence of delay differential equations with high-slope right-hand sides, one can obtain a Filippov solution of delayed neural networks with discontinuous activations. The same approach enables us to obtain a solution to system (7.1.1) in the sense of Definition 7.1.1, i.e., one can first construct a sequence of delay differential equations with high-slope right-hand sides and then prove that the solutions approach a solution of (7.1.1) in the sense of Definition 7.1.1. The approach is similar to that of [132] and [133], except that we consider both time-varying delays and distributed delays here. We shall only sketch the main steps and more details can be found in [132] and [133]. Throughout the section, let g_i , $i = 1, 2, \dots, n$, be fixed class \mathcal{G} functions and ϕ and ψ be initial functions satisfying the assumptions in Definition 7.1.1.

Step 1 (Construction of High-Slope Functions). Let $\{Q_{k,i}\}$ be the set of discontinuous points of g_i . Pick a strictly decreasing $\{\delta_{k,i,m}\}$ with $\lim_{m \rightarrow \infty} \delta_{k,i,m} = 0$, and let $J_{k,i,m} = [Q_{k,i} - \delta_{k,i,m}, Q_{k,i} + \delta_{k,i,m}]$ be intervals such that $J_{k_1,i,m} \cap J_{k_2,i,m} = \emptyset$ for $k_1 \neq k_2$. Define $g_i^m(\cdot)$ by letting $g_i^m(s) = g_i(s)$ if $s \notin J_{k,i,m}$ for any k , and

$$g_i^m(s) = \frac{g_i^+ - g_i^-}{2\delta_{k,i,m}}(s - Q_{k,i} - \delta_{k,i,m}) + g_i^+,$$

where

$$g_i^+ = g_i(Q_{k,i} + \delta_{k,i,m}) \quad \text{and} \quad g_i^- = g_i(Q_{k,i} - \delta_{k,i,m}).$$

We can observe the following properties of the sequence of functions $\{g^m(\cdot)\}$:

- (i) each function $g^m : \mathcal{R}^n \rightarrow \mathcal{R}^n$ is a diagonal mapping, i.e.,

$$g^m(x) = [g_1^m(x_1), \dots, g_n^m(x_n)]^T,$$

and g_i^m is nondecreasing and continuous, for $i = 1, \dots, n$;

(ii) for each compact set $W \subset \mathcal{R}^n$, there exists a constant $C = C(W) > 0$, independent of the choice of g^m in the sequence, such that $|g_i^m(x)| \leq C$ holds for all $x \in W$ and $i = 1, \dots, n$;

(iii) we have

$$\lim_{m \rightarrow \infty} d_H(\text{Graph}(g^m(S)), K[g(S)]) = 0,$$

for all $S \subset \mathcal{R}^n$, where $d_H(\cdot, \cdot)$ denotes the Hausdorff metric of \mathcal{R}^n .

Step 2 (Local Solutions to DDEs with High-Slope RHS). For each g^m , consider the following system of delay differential equations

$$\begin{aligned} \frac{dy_i(t)}{dt} = & -d_i y_i(t) + \sum_{j=1}^n a_{ij} g_j^m(y_j(t)) + \sum_{j=1}^n b_{ij} y_j g_j^m(y_j(t - \tau_{ij}(t))) \\ & + \sum_{j=1}^n c_{ij} \int_0^\infty g_j^m(y_j(t-s)) p_{ij}(s) ds + I_i, \quad i = 1, \dots, n, \quad t \geq 0, \end{aligned} \quad (7.3.1)$$

with $y_i(s) = \phi_i(s)$ for all $s \in (-\infty, 0]$. Following the classical theory of functional differential equations (see [62] and [70]) and based on the properties observed above for the sequence $\{g^m\}$, there exists an $\alpha > 0$ such that, for any g^m in the sequence, there is a solution to (7.3.1) on $[0, \alpha]$. Therefore, we obtain a sequence of solutions $\{y^m(t)\}$ to (7.3.1) on $[0, \alpha]$.

Step 3 (Boundedness of Solutions to (7.3.1) and Continuation). Using a similar Lyapunov functional approach as in the proof of Theorems 7.2.2 and 7.2.4, under the matrix inequality (7.2.1) and Assumption 7.2.1, respectively, one can show that the solutions $\{y^m(t)\}$ are uniformly bounded and hence, by [62], they can be extended to the interval $[0, \infty)$. Therefore, we obtain a sequence of solutions $\{y^m(t)\}$ to (7.3.1) on $[0, \infty)$ which are uniformly bounded (the bound is independent of m).

Step 4 (Convergence to a Filippov Solution). This part is essentially Lemma 2 in [133], only now we take the time-varying delays into account. Using Mazur's convexity theorem [198] and property (iii) of the sequence $\{g^m(\cdot)\}$ (see step 1), one can obtain a sequence of functions, which is a convex combination of the original sequence $\{y^m(t)\}$, converges to a solution of (7.1.1) in the sense of Definition 7.1.1 (for details, e.g., how the output $\gamma(t)$ is constructed, see [133]).

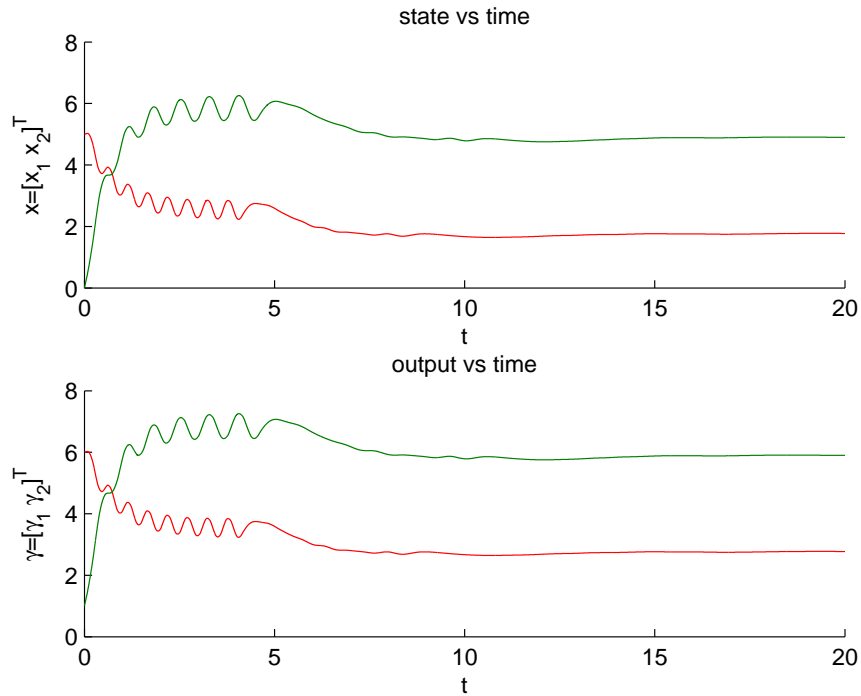

Figure 7.1 Simulation results for Example 7.4.1.

7.4 Examples

Example 7.4.1 Consider the second-order neural network (7.1.1) with $D = \text{diag}\{0.01, 0.01\}$ and

$$A = \begin{bmatrix} -1.5 & -0.1 \\ 0.1 & -1.5 \end{bmatrix}, \quad B = \begin{bmatrix} 0.4 & -0.4 \\ 0.35 & -0.35 \end{bmatrix}.$$

Suppose $C = 0$ (i.e., no distributed delays). Let $\tau_{11}(t) = \tau_{12}(t) = 5 - \sin(t/4)$, $\tau_{21}(t) = \tau_{22}(t) = 5 - \cos(t/4)$, $I = [6 \ 10]^T$, and $g_1(s) = g_2(s) = s + \text{sign}(s)$. Hence $\tau'_{ij}(t) \leq \rho = 1/4$. It can be easily verified that Assumption 7.2.1 is satisfied. Consider the IVP of (7.1.1) with initial conditions $\phi(t) = [5 \cos(10t), -5 \cos(10t)]$ for $t \in [-6, 0]$, and $\psi(t) = [g_1(5 \cos(10t)), g_2(-5 \cos(10t))]$ for $t \in [-6, 0]$. Figure 7.1 shows that both the simulated state $x(t)$ and output $\gamma(t)$ converge to the unique equilibrium point, which is in accordance with the conclusions of Theorem 7.2.4. \square

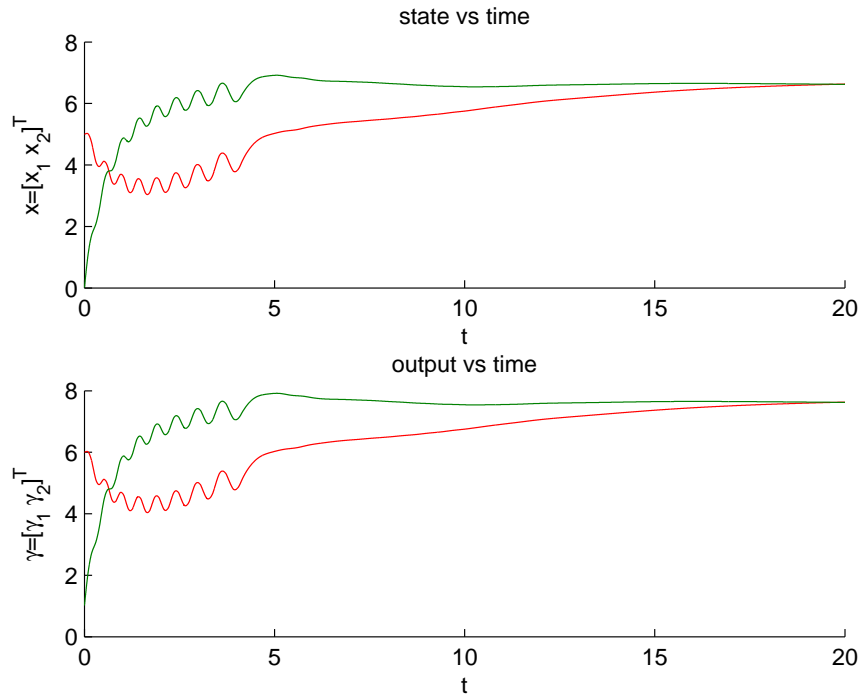

Figure 7.2 Simulation results for Example 7.4.2.

Example 7.4.2 Consider Example 7.4.1 with distributed delays given by

$$C = \begin{bmatrix} -0.2 & -0.1 \\ 0.1 & -0.25 \end{bmatrix}, \quad p_{ij}(s) = \begin{cases} \frac{1}{6}, & s \in [0, 6], \\ 0, & s \in (6, \infty). \end{cases}$$

Let $\tau_{ij}(t) = \tau(t) = 5 - \sin(t/2)$ and $g_1(s) = g_2(s) = s + \text{sign}(s)$. Hence $\tau'_{ij}(t) \leq \rho = 1/2$. It can be seen that Assumption 7.2.1 (M-matrix condition) no longer holds. However, using the MATLAB LMI control toolbox [52], we can check that the matrix inequality (7.2.1) is satisfied. We present simulation results for two different inputs. With input $I = [6 \ 10]^T$ and under the same initial conditions as in Example 7.4.1, Figure 7.2 shows that both the simulated state $x(t)$ and the output $\gamma(t)$ converge to the unique equilibrium point $\xi = [6.8512 \ 6.6327]^T$ and the unique output equilibrium point $\eta = g(\xi) = [7.8512 \ 7.6327]$, respectively, which is in accordance with the conclusions of Theorem 7.2.2. Here the convergence of the output is in the usual sense since $g(x)$ is continuous at $\xi = [6.8512 \ 6.6327]^T$. With input $I = [0.65 \ -1.2]^T$, it can be shown that the unique equilibrium is $\xi = [0 \ 0]^T$ and the unique output equilibrium $\eta = [1 \ -1]^T$. In

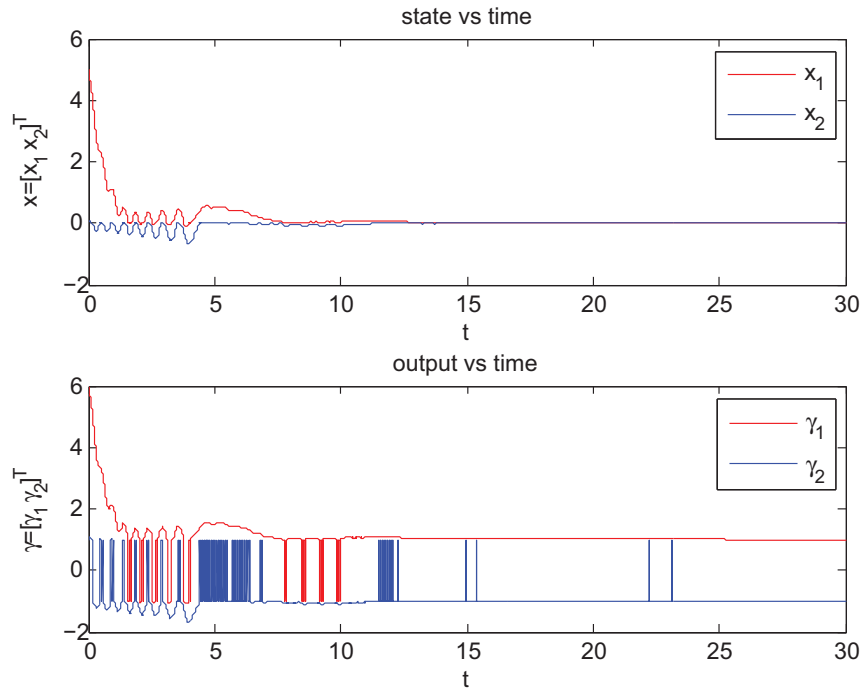

Figure 7.3 Simulation results for Example 7.4.2.

this case $g(x)$ is discontinuous at $\xi = [0 \ 0]^T$ and the convergence of output to η is in the measure sense. Figure 7.3 shows the corresponding simulations. \square

7.5 Summary

In this chapter, we investigated the dynamical behavior of a class of neural networks with mixed time-delays and discontinuous neuron activations. Both time-varying delays and distributed delays were considered, while almost all of the recent work on neural networks with discontinuous neuron activations considered only constant delays. We established two sets of sufficient conditions for both the global exponential stability of the neuron state and global convergence of the neuron output. These results extend previous work on global stability of delayed neural networks with Lipschitz continuous neuron activations, and neural networks with discontinuous neuron activations and only constant delays.

We conclude by pointing out a few questions not answered in this chapter. In [51] and [50], the important notions of convergence in finite time for both the neuron state and neuron

output are investigated. One of the key point is that, after the neuron state converges to the equilibrium point in finite time, the output can be shown to obey an algebraic memoryless equation [50]. As for neuron networks with time-varying delays and distributed delays, the relation can get significantly more involved. Also, as shown in [50], the uniqueness of solution (both the neuron state and output) is closely related to the convergence in finite time. In this chapter, the uniqueness of solution is not discussed. However, we have shown that, under the theorem conditions, all solutions will converge to the unique equilibrium point. Furthermore, it remains an interesting topic whether the model of discontinuous neural networks can be extended to a stochastic one, so that the stochastic model can cover the situation with random noises.

C H A 8 P T E R

Conclusions and Future Research

The objective of this thesis has been to present a coherent study of various aspects of hybrid dynamical systems related to the fundamental theory, invariance principles, stability and stabilization issues, and related application problems. Particular emphasis has been given to systems with nonlinearity and time-delays and subject to random disturbances.

In this chapter, we summarize the main results presented in this thesis and relate them to possible future research.

Fundamental Theory

Impulse and delay together make it necessary to formulate solutions of an impulsive delay system in the space of piecewise continuous functions as shown in [9]. When there are random disturbances, we are forced to study stochastic differential equations in the space of piecewise continuous functions. In Chapter 5, we have developed the fundamental theory regarding the existence and uniqueness of solutions for general hybrid systems with time-delay. In this theory, the impulsive switching signals are assumed to be time-dependent and deterministic.

While this theory can be generalized to stochastic time-dependent signals with stopping times as impulsive switching times in a straightforward manner, future research can be focused on a particularly challenging case in which the hybrid signals are state-dependent.

Other aspects of the fundamental theory such as continuous dependence and differentiability of solutions with respect to the initial data can also be investigated. A theory of hybrid systems with neutral-type delays, in addition to the theory developed in this thesis,

might be of both theoretical and practical interest. While the theory in this thesis focus on stochastic systems subject to deterministic hybrid signals, a more general theory of stochastic hybrid systems can be formulated using more advanced theory of hybrid switching and jump diffusions.

Invariance Principles

Invariance principles characterize asymptotic stability of nonlinear systems in the absence of strict Lyapunov functions. In this thesis, invariance principles have been established for both switched delay systems and impulsive switched systems.

Future research can be directed to establish invariance principles for general hybrid systems with time-delay and stochastic hybrid systems. Similar to the fundamental theory, if both impulses and time-delay are present, the challenge in establishing invariance principles for such hybrid systems lies not only in that the solutions of such systems are discontinuous, but also in that the state space becomes a non-complete infinite-dimensional space. In such a situation, a new topology such as the Skorohod topology on the space of piecewise continuous functions [14] might be used to overcome the difficulty encountered by the usual supremum topology. For stochastic hybrid systems, one may not expect the same invariance-like properties as in the deterministic case. LaSalle-type theorems for locating the limit set of stochastic hybrid systems could be very useful as shown in [139].

Stability in Two Measures and Input/Output Stability Notions

Input-to-state stability analysis extends the Lyapunov stability theory by considering robustness with respect to external inputs and disturbances [164]. In this thesis, input-to-state stability properties have been studied for impulsive switched systems with and without time-delays. Stability in terms of two measures unifies various stability notions [100]. In Chapter 3, we have formulated and investigated input-to-state stability in terms of two measures, which bridges the existent theories of stability analysis in two measures and input/output theories for nonlinear systems.

General outputs are not considered in this thesis. Future research can be directed to establish general input/output stability theories for hybrid systems and, particularly, hybrid time-delay systems, following the recent results in [84], [85], and [86]. It is interesting to note that input-to-output stability analysis has a somewhat similar formulation as that of

stability in two measures, where input is understood as one measure and output the other. It would be interesting to know if this formal similarity can help to provide a unified theory.

Input-to-state stability for stochastic systems received increasing attention in recent years ([75], [110], [170], [171]). Stochastic hybrid systems have not been investigated with few exceptions [75]. Future research can be conducted along this line.

Applications

Two application problems relevant to the qualitative studies of hybrid systems have been studied in this thesis. Namely, the consensus problem in networked multi-agent systems and global convergence of artificial neural networks with discontinuous neuron activation functions and mixed time-delays.

As introduced in Chapter 1, hybrid systems have diverse applications. One important perspective is that networked systems often are subjected to communication time-delays and operated in an uncertain environment. Hybrid time-delay systems and stochastic hybrid systems are most suited for the studying of these practical applications. Future research can be done to explore more real-world applications along this line either by applying existent theories or developing new theories.

Numerical Methods and Stability

For many practical systems, it is very difficult, if not impossible, to obtain analytical solutions. Therefore, numerical approaches have to be applied. Although numerical simulations have been conducted throughout the thesis, a general theory concerning the numerical methods for hybrid systems is not developed. In contrast with those well-developed numerical methods for ordinary differential equations and stochastic differential equations, general theories concerning numerical schemes for hybrid time-delay systems and stochastic hybrid systems are largely not available. Future research can be done to develop accurate and efficient numerical schemes to solve these hybrid systems and apply them to the numerical determination of both Lyapunov exponents and moment Lyapunov exponents, which are of great importance in characterizing the qualitative behavior of hybrid time-delay systems and stochastic hybrid systems.

Bibliography

1. M.S. ALWAN AND X. LIU. On stability of linear and weakly nonlinear switched systems with time delay. *Mathematical and Computer Modelling*, **48**(7-8), pp. 1150–1157, 2008.
2. L. ARNOLD. *Stochastic Differential Equations: Theory and Applications*. Wiley-Interscience, New York, 1974.
3. J.P. AUBIN AND H. FRANKOWSKA. *Set-Valued Analysis*. Springer, 1990.
4. A. BACCIOTTI AND L. MAZZI. An invariance principle for nonlinear switched systems. *Systems & Control Letters*, **54**(11), pp. 1109–1119, 2005.
5. A. BACCIOTTI AND L. MAZZI. From artstein-sontag theorem to the min-projection strategy. *Transactions of the Institute of Measurement and Control*, 2009.
6. A. BACCIOTTI. Stabilization by means of state space depending switching rules. *Systems & Control Letters*, **53**(3-4), pp. 195–201, 2004.
7. D.D. BAINOV AND P.S. SIMEONOV. *Systems with Impulse Effect Stability, Theory and Applications*. Ellis Horwood Series in Mathematics and Its Applications. Ellis Horwood Ltd., Chichester, 1989.
8. G.H. BALLINGER. *Qualitative Theory of Impulsive Delay Differential Equations*. PhD thesis, University of Waterloo, 1999.
9. G. BALLINGER AND X. LIU. Existence and uniqueness results for impulsive delay differential equations. *Dynamics of Continuous, Discrete and Impulsive Systems: Series A, Mathematical Analysis*, **5**, pp. 579–591, 1999.
10. G. BALLINGER AND X. LIU. Practical stability of impulsive delay differential equations and applications to control problems. In *Optimization Methods and Applications*, VOL. 52 of *Applied Optimization*, pp. 3–21. Kluwer Academic Publishers, Dordrecht, Netherlands, 2001.
11. D. BAUSO, L. GIARRÉ, AND R. PESENTI. Consensus for networks with unknown but bounded disturbances. *SIAM Journal on Control and Optimization*, **48**(3), pp. 1756–1770, 2009.

12. R. BELLMAN. Topics in pharmacokinetics, iii: Repeated dosage and impulse control. *Mathematical Biosciences*, **12**(1-2), pp. 1–5, 1971.
13. L. BEREZANSKY AND E. BRAVERMAN. Impulsive stabilization of linear delay differential equations. *Dynamic Systems and Applications*, **5**(2), pp. 263–276, 1996.
14. P. BILLINGSLEY. *Convergence of Probability Measures*. Wiley, New York, 1968.
15. P.A. BLIMAN AND G. FERRARI-TRECCATE. Average consensus problems in networks of agents with delayed communications. *Automatica*, **44**(8), pp. 1985–1995, 2008.
16. H.A.P. Blom and J. Lygeros, editors. *Stochastic Hybrid Systems: Theory and Safety Critical Applications*, VOL. 337 of *Lecture Notes in Control and Information Sciences*. Springer-Verlag, Berlin, 2006.
17. V. BORKAR AND P. VARAIYA. Asymptotic agreement in distributed estimation. *IEEE Transactions on Automatic Control*, **27**(3), pp. 650–655, 2002.
18. U. BOSCAIN. Stability of planar switched systems: the linear single input case. *SIAM Journal on Control and Optimization*, **41**(1), pp. 89–112, 2003.
19. S. BOYD, L. EL GHAOU, E. FERON, AND V. BALAKRISHNAN. *Linear Matrix Inequalities in System and Control Theory*. Society for Industrial Mathematics, 1994.
20. M.S. BRANICKY. Multiple Lyapunov functions and other analysis tools for switched and hybrid systems. *IEEE Transactions on Automatic Control*, **43**(4), pp. 475–482, 1998.
21. E. BRAVERMAN AND R. MAMDANI. Continuous versus pulse harvesting for population models in constant and variable environment. *Journal of Mathematical Biology*, **57**(3), pp. 413–434, 2008.
22. B. BRU AND M. YOR. Comments on the life and mathematical legacy of Wolfgang Doeblin. *Finance and Stochastics*, **6**(1), pp. 3–47, 2002.
23. C. CAI AND A.R. TEEL. Results on input-to-state stability for hybrid systems. In *Proceedings of the 44th IEEE Conference on Decision and Control and 2005 European Control Conference*, pp. 5403 – 5408, 2005.
24. C. CAI AND A.R. TEEL. Characterizations of input-to-state stability for hybrid systems. *Systems & Control Letters*, **58**(1), pp. 47–53, 2009.
25. J. CAO AND J. LIANG. Boundedness and stability for cohen-grossberg neural network with time-varying delays. *Journal of Mathematical Analysis and Applications*, **296**(2), pp. 665–685, 2004.

26. J. CAO AND J. WANG. Global asymptotic stability of a general class of recurrent neural networks with time-varying delays. *IEEE Transactions on Circuits and Systems I: Fundamental Theory and Applications*, **50**(1), pp. 34–44, 2003.
27. J. CAO, K. YUAN, AND H.X. LI. Global asymptotical stability of recurrent neural networks with multiple discrete delays and distributed delays. *IEEE Transactions on Neural Networks*, **17**(6), pp. 1646–1651, 2006.
28. M. CAO, A.S. MORSE, AND B.D.O. ANDERSON. Reaching a consensus in a dynamically changing environment: A graphical approach. *SIAM Journal on Control and Optimization*, **47**(2), pp. 575–600, 2008.
29. M. CAO, A.S. MORSE, AND B.D.O. ANDERSON. Reaching a consensus in a dynamically changing environment: Convergence rates, measurement delays, and asynchronous events. *SIAM Journal on Control and Optimization*, **47**(2), pp. 601–623, 2008.
30. R. CARLI, F. FAGNANI, A. SPERANZON, AND S. ZAMPIERI. Communication constraints in the average consensus problem. *Automatica*, **44**(3), pp. 671–684, 2008.
31. T.E. CARTER. Optimal impulsive space trajectories based on linear equations. *Journal of Optimization Theory and Applications*, **70**(2), pp. 277–297, 1991.
32. C.G. Cassandras and J. Lygeros, editors. *Stochastic Hybrid Systems*. Automation and Control Engineering. CRC Press, Boca Raton, FL, 2007.
33. F. CERAGIOLI. Finite valued feedback laws and piecewise classical solutions. *Nonlinear Analysis*, **65**(5), pp. 984–998, 2006.
34. D. CHATTERJEE AND D. LIBERZON. Stability analysis of deterministic and stochastic switched systems via a comparison principle and multiple Lyapunov functions. *SIAM Journal on Control and Optimization*, **45**(1), pp. 174–206, 2007.
35. V.S. CHELLABOINA, S.P. BHAT, AND W.M. HADDAD. An invariance principle for nonlinear hybrid and impulsive dynamical systems. *Nonlinear Analysis*, **53**(3-4), pp. 527–550, 2003.
36. W.H. CHEN AND W.X. ZHENG. Input-to-state stability and integral input-to-state stability of nonlinear impulsive systems with delays. *Automatica*, **45**(6), pp. 1481–1488, 2009.
37. P.P. CIVALLERI, M. GILLI, AND L. PANDOLFI. On stability of cellular neural networks with delay. *IEEE Transactions on Circuits and Systems I: Fundamental Theory and Applications*, **40**(3), pp. 157–165, 1993.

38. F.H. CLARKE. *Optimization and Nonsmooth Analysis*. Society for Industrial Mathematics, 1990.
39. M.A. CRUZ AND J.K. HALE. Stability of functional differential equations of neutral type. *Journal of Differential Equations*, 7(2), pp. 334–355, 1970.
40. W.P. DAYAWANSA AND C.F. MARTIN. A converse Lyapunov theorem for a class of dynamical systems which undergo switching. *IEEE Transactions on Automatic Control*, 44(4), pp. 751–760, APR. 1999.
41. R.A. DECARLO, M.S. BRANICKY, S. PETTERSSON, AND B. LENNARTSON. Perspectives and results on the stability and stabilizability of hybrid systems. *Proceedings of the IEEE*, 88(7), pp. 1069–1082, 2000.
42. M.H. DEGROOT. Reaching a consensus. *Journal of the American Statistical Association*, 69(345), pp. 118–121, 1974.
43. G.A. DE CASTRO AND F. PAGANINI. Convex synthesis of controllers for consensus. In *Proceedings of the 2004 American Control Conference*, pp. 4933–4938, 2004.
44. O. DIEKMANN. *Delay Equations: Functional-, Complex-, and Nonlinear Analysis*. Springer, New York, 1995.
45. R.D. DRIVER. *Ordinary and Delay Differential Equations*. Springer-Verlag, New York, 1977.
46. J.A. FAX AND R.M. MURRAY. Information flow and cooperative control of vehicle formations. *IEEE Transactions on Automatic Control*, 49(9), pp. 1465–1476, 2004.
47. M. FIEDLER. Algebraic connectivity of graphs. *Czechoslovak Mathematical Journal*, 23(2), pp. 298–305, 1973.
48. A.F. FILIPPOV. *Differential Equations with Discontinuous Righthand Sides*. Kluwer Academic Publishers, Dordrecht, Netherlands, 1988.
49. M. FORTI, M. GRAZZINI, P. NISTRÌ, AND L. PANCIONI. Generalized Lyapunov approach for convergence of neural networks with discontinuous or non-Lipschitz activations. *Physica D: Nonlinear Phenomena*, 214(1), pp. 88–99, 2006.
50. M. FORTI, P. NISTRÌ, AND D. PAPINI. Global exponential stability and global convergence in finite time of delayed neural networks with infinite gain. *IEEE Transactions on Neural Networks*, 16(6), pp. 1449–1463, 2005.

51. M. FORTI AND P. NISTRÌ. Global convergence of neural networks with discontinuous neuron activations. *IEEE Transactions on Circuits and Systems I: Fundamental Theory and Applications*, **50**(11), pp. 1421–1435, 2003.
52. P. GAHINET, A. NEMIROVSKII, A.J. LAUB, AND M. CHILALI. The LMI control toolbox. In *Decision and Control, 1994., Proceedings of the 33rd IEEE Conference on*, VOL. 3, pp. 2038–2041. IEEE, 2002.
53. I.I. GIHMAN AND A. V. SKOROHOD. *Stochastic Differential Equations*. Springer-Verlag, New York, 1972. Translated from the Russian by Kenneth Wickwire, *Ergebnisse der Mathematik und ihrer Grenzgebiete*, Band 72.
54. R. GOEBEL, R.G. SANFELICE, AND A.R. TEEL. Invariance principles for switching systems via hybrid systems techniques. *Systems & Control Letters*, **57**(12), pp. 980–986, 2008.
55. R. GOEBEL, R.G. SANFELICE, AND A.R. TEEL. Hybrid dynamical systems. *IEEE Control Systems Magazine*, **29**(2), pp. 28–93, 2009.
56. A. GRANAS AND J. DUGUNDJI. *Fixed Point Theory*. Springer Verlag, New York, 2003.
57. K. GU. An integral inequality in the stability problem of time-delay systems. In *Proceedings of the 39th IEEE Conference on Decision and Control*, pp. 2805–2810, 2000.
58. G. HADDAD. Monotone viable trajectories for functional differential inclusions. *Journal of Differential Equations*, **42**(1), pp. 1–24, 1981.
59. J.R. HADDOCK, T. KRISZTIN, J. TERJÉKI, AND J.H. WU. An invariance principle of Lyapunov-Razumikhin type for neutral functional differential equations. *Journal of Differential Equations*, **107**(2), pp. 395–417, 1994.
60. J.R. HADDOCK AND J. TERJEKI. Liapunov-Razumikhin functions and an invariance principle for functional differential equations. *Journal of differential equations*, **48**(1), pp. 95–122, 1983.
61. A. HALANAY. *Differential Equations: Stability, Oscillations, Time Lags*. Academic Press, New York, 1966.
62. J.K. HALE AND S.M.V. LUNEL. *Introduction to Functional Differential Equations*. Springer, New York, 1993.
63. J.K. HALE. Sufficient conditions for stability and instability of autonomous functional differential equations. *Journal of Differential Equations*, **1**, pp. 452–482, 1965.

64. Y. HATANO AND M. MESBAHI. Agreement over random networks. *IEEE Transactions on Automatic Control*, **50**(11), pp. 1867–1872, 2005.
65. S. HAYKIN. *Neural Networks: A Comprehensive Foundation*. Prentice Hall PTR Upper Saddle River, NJ, USA, 1994.
66. J.P. HESPANHA, D. LIBERZON, D. ANGELI, AND E.D. SONTAG. Nonlinear norm-observability notions and stability of switched systems. *IEEE Transactions on Automatic Control*, **50**(2), pp. 154–168, 2005.
67. J.P. HESPANHA, D. LIBERZON, AND A.R. TEEL. Lyapunov conditions for input-to-state stability of impulsive systems. *Automatica*, **44**(11), pp. 2735–2744, 2008.
68. J.P. HESPANHA AND A.S. MORSE. Stability of switched systems with average dwell-time. In *Proceedings of the 38th IEEE Conference on Decision and Control*, pp. 2655–2660, 1999.
69. J.P. HESPANHA. Uniform stability of switched linear systems: extensions of LaSalle’s invariance principle. *IEEE Transactions on Automatic Control*, **49**(4), pp. 470–482, 2004.
70. Y. HINO, S. MURAKAMI, AND T. NAITO. *Functional Differential Equations with Infinite Delay*, VOL. 1473 of *Lecture Notes in Mathematics*. Springer-Verlag, Berlin, 1991.
71. J.J. HOPFIELD AND D.W. TANK. Computing with neural circuits: A model. *Science*, **233**(4764), pp. 625–633, 1986.
72. J.J. HOPFIELD. Neurons with graded response have collective computational properties like those of two-state neurons. *Proceedings of the National Academy of Sciences of the United States of America*, **81**(10), pp. 3088, 1984.
73. R.A. HORN AND C.R. JOHNSON. *Topics in Matrix Analysis*. Cambridge Univ Press, 1994.
74. L. HOU, A.N. MICHEL, AND H. YE. Stability analysis of switched systems. In *Proceedings of the 35th IEEE Conference on Decision and Control*, VOL. 2, pp. 1208–1212. IEEE, 1996.
75. L. HUANG AND X. MAO. On input-to-state stability of stochastic retarded systems with Markovian switching. *IEEE Transactions on Automatic Control*, **54**(8), pp. 1898–1902, 2009.
76. M. HUANG, S. DEY, G.N. NAIR, AND J.H. MANTON. Stochastic consensus over noisy networks with markovian and arbitrary switches. *Automatica*, **46**(10), pp. 1571–1583, 2010.

77. M. HUANG AND J.H. MANTON. Coordination and consensus of networked agents with noisy measurements: Stochastic algorithms and asymptotic behavior. *SIAM Journal on Control and Optimization*, **48**(1), pp. 134–161, 2009.
78. M. HUANG AND J.H. MANTON. Stochastic consensus seeking with noisy and directed inter-agent communication: fixed and randomly varying topologies. *IEEE Transactions on Automatic Control*, **55**(1), pp. 235–241, 2010.
79. K. ITÔ AND M. NISIO. On stationary solutions of a stochastic differential equation. *Journal of Mathematics of Kyoto University*, **4**, pp. 1–75, 1964.
80. K. ITÔ. On stochastic differential equations. *Memoirs of the American Mathematical Society*, **1951**(4), pp. 1–51, 1951.
81. A. JADBABAIE, J. LIN, AND A.S. MORSE. Coordination of groups of mobile autonomous agents using nearest neighbor rules. *IEEE Transactions on Automatic Control*, **48**(6), pp. 988–1001, 2003.
82. R. JESSOP AND S.A. CAMPBELL. Approximating the stability region of a neural network with a general distribution of delays. *Neural Networks*, **IN PRESS, CORRECTED PROOF**, pp. –, 2010.
83. Z.P. JIANG AND Y. WANG. Input-to-state stability for discrete-time nonlinear systems. *Automatica*, **37**(6), pp. 857–869, 2001.
84. I. KARAFYLLIS, P. PEPE, AND Z.P. JIANG. Global output stability for systems described by retarded functional differential equations: Lyapunov characterizations. *European Journal of Control*, **14**(6), pp. 516–536, 2008.
85. I. KARAFYLLIS, P. PEPE, AND Z.P. JIANG. Input-to-output stability for systems described by retarded functional differential equations. *European Journal of Control*, **14**(6), pp. 539–555, 2008.
86. I. KARAFYLLIS, P. PEPE, AND Z.P. JIANG. Stability results for systems described by coupled retarded functional differential equations and functional difference equations. *Nonlinear Analysis: Theory, Methods & Applications*, **71**(7-8), pp. 3339–3362, 2009.
87. A. KHADRA, X. LIU, AND X. SHEN. Application of impulsive synchronization to communication security. *IEEE Transactions on Circuits and Systems I: Fundamental Theory and Applications*, **50**(3), pp. 341–351, 2005.

88. A. KHADRA, X. LIU, AND X. SHEN. Impulsively synchronizing chaotic systems with delay and applications to secure communication. *Automatica*, **41**(9), pp. 1491–1502, 2005.
89. A. KHADRA, X. LIU, AND X. SHEN. Analyzing the robustness of impulsive synchronization coupled by linear delayed impulses. *IEEE Transactions on Automatic Control*, **54**(4), pp. 923–928, 2009.
90. H.K. KHALIL. *Nonlinear Systems*. Prentice Hall, third edition, 2002.
91. S. KIM, S.A. CAMPBELL, AND X. LIU. Stability of a class of linear switching systems with time delay. *IEEE Transactions on Circuits and Systems I: Regular Papers*, **53**(2), pp. 384–393, 2006.
92. S. KIM, S.A. CAMPBELL, AND X. LIU. Delay independent stability of linear switching systems with time delay. *Journal of Mathematical Analysis and Applications*, **339**(2), pp. 785–801, 2008.
93. V.B. KOLMANOVSKII AND V.R. NOSOV. *Stability of Functional-Differential Equations*, VOL. 180 of *Mathematics in Science and Engineering*. Academic Press, London, 1986.
94. V. KOLMANOVSKII AND A. MYSHKIS. *Introduction to The Theory and Applications of Functional-Differential Equations*, VOL. 463 of *Mathematics and its Applications*. Kluwer Academic Publishers, Dordrecht, 1999.
95. H.J. KUSHNER. *Probability Methods for Approximations in Stochastic Control and for Elliptic Equations*. Academic Press, New York, 1977.
96. H.J. KUSHNER. *Numerical Methods for Controlled Stochastic Delay Systems*. Birkhauser, 2008.
97. V. LAKSHMIKANTHAM, D. BAINOV, AND P.S. SIMEONOV. *Theory of Impulsive Differential Equations*. World Scientific Publishing, NJ, 1989.
98. V. LAKSHMIKANTHAM AND S. LEELA. *Differential and Integral Inequalities: Theory and Applications. Vol. I. Ordinary Differential Equations*. Academic Press, 1969.
99. V. LAKSHMIKANTHAM AND X. LIU. On quasi stability for impulsive differential systems. *Nonlinear Analysis*, **13**(7), pp. 819–828, 1989.
100. V. LAKSHMIKANTHAM AND X. LIU. *Stability Analysis in Terms of Two Measures*. World Scientific Publishing, NJ, 1993.
101. J.P. LASALLE. The extent of asymptotic stability. *Proceedings of the National Academy of Sciences of the United States of America*, **46**(3), pp. 363–365, 1960.

102. J.P. LASALLE. Some extensions of Liapunov's second method. *IRE Transactions on Circuit Theory*, 7(4), pp. 520–527, DEC. 1960.
103. J.P. LASALLE. *The Stability of Dynamical Systems*. Regional Conference Series in Applied Mathematics. Society for Industrial and Applied Mathematics, Philadelphia, PA, 1976.
104. TC LEE AND ZP JIANG. Uniform asymptotic stability of nonlinear switched systems with an application to mobile robots. *IEEE Transactions on Automatic Control*, 53(5), pp. 1235–1252, 2008.
105. Y.C. LIAO. Switching and impulsive control of a reflected diffusion. *Applied Mathematics and Optimization*, 11(1), pp. 153–159, 1984.
106. D. LIBERZON AND A.S. MORSE. Basic problems in stability and design of switched systems. *IEEE Control Systems Magazine*, 19(5), pp. 59–70, 1999.
107. D. LIBERZON. *Switching in Systems and Control*. Birkhauser, Boston, MA, 2003.
108. B. LIU, X. LIU, G. CHEN, AND H. WANG. Robust impulsive synchronization of uncertain dynamical networks. *IEEE Transactions on Circuits and Systems I: Regular Papers*, 52(7), pp. 1431–1441, 2005.
109. J. LIU, X. LIU, AND W.C. XIE. Delay-dependent robust control for uncertain switched systems with time-delay. *Nonlinear Analysis: Hybrid Systems*, 2(1), pp. 81–95, 2008.
110. S.J. LIU, J.F. ZHANG, AND Z.P. JIANG. A notion of stochastic input-to-state stability and its application to stability of cascaded stochastic nonlinear systems. *Acta Mathematicae Applicatae Sinica. English Series*, 24(1), pp. 141–156, 2008.
111. X. LIU AND G. BALLINGER. Existence and continuability of solutions for differential equations with delays and state-dependent impulses. *Nonlinear Analysis: Theory, Methods & Applications*, 51(4), pp. 633–647, 2002.
112. X. LIU AND K. ROHLF. Impulsive control of a Lotka-Volterra system. *IMA Journal of Mathematical Control and Information*, 15(3), pp. 269, 1998.
113. X. LIU, X. SHEN, H. ZHANG, AND J. LIU. A family of new chaotic and hyperchaotic attractors from delay differential equations. Submitted, 2010.
114. X. LIU AND P. STECHLINSKI. Pulse and constant control schemes for epidemic models with seasonality. *Nonlinear Analysis: Real World Applications*, 2010.
115. X. LIU AND Q. WANG. The method of Lyapunov functionals and exponential stability of impulsive systems with time delay. *Nonlinear Analysis*, 66(7), pp. 1465–1484, 2007.

116. X. LIU AND Q. WANG. Impulsive stabilization of high-order Hopfield-type neural networks with time-varying delays. *IEEE Transactions on Neural Networks*, **19**(1), pp. 71–79, 2008.
117. X. LIU. Quasi stability via Lyapunov functions for impulsive differential systems. *Applicable Analysis*, **31**(3), pp. 201–213, 1988.
118. X. LIU. On (h_0, h) -stability of autonomous systems. *Journal of Applied Mathematics and Stochastic Analysis*, **5**(4), pp. 331–337, 1992.
119. X. LIU. Impulsive stabilization of nonlinear systems. *IMA Journal of Mathematical Control and Information*, **10**(1), pp. 11–19, 1993.
120. X. LIU. Stability results for impulsive differential systems with applications to population growth models. *Dynamical Systems*, **9**(2), pp. 163–174, 1994.
121. X. LIU. Impulsive stabilization and applications to population growth models. *The Rocky Mountain Journal of Mathematics*, **25**(1), pp. 381–395, 1995.
122. X. LIU. Impulsive stabilization and control of chaotic system. *Nonlinear Analysis*, **47**, pp. 1081–1092, 2001.
123. C. LI, L. CHEN, AND K. AIHARA. Impulsive control of stochastic systems with applications in chaos control, chaos synchronization, and neural networks. *Chaos: An Interdisciplinary Journal of Nonlinear Science*, **18**, pp. 023132, 2008.
124. C. LI, X. LIAO, X. YANG, AND T. HUANG. Impulsive stabilization and synchronization of a class of chaotic delay systems. *Chaos: An Interdisciplinary Journal of Nonlinear Science*, **15**, pp. 043103, 2005.
125. J.H. LI, AN MICHEL, AND W. POROD. Analysis and synthesis of a class of neural networks: Variable structure systems with infinite grain. *IEEE Transactions on Circuits and Systems*, **36**(5), pp. 713–731, 1989.
126. M.Y. LI, J.R. GRAEF, L. WANG, AND J. KARSAI. Global dynamics of a seir model with varying total population size. *Mathematical Biosciences*, **160**(2), pp. 191–213, 1999.
127. T. LI AND J.F. ZHANG. Mean square average-consensus under measurement noises and fixed topologies: Necessary and sufficient conditions. *Automatica*, **45**(8), pp. 1929–1936, 2009.
128. Y. LI, X. LIU, AND H. ZHANG. Dynamical analysis and impulsive control of a new hyperchaotic system. *Mathematical and Computer Modelling*, **42**(11–12), pp. 1359–1374, 2005.

129. Z. LI, Y. SOH, AND C. WEN. *Switched and Impulsive Systems: Analysis, Design and Applications*. Springer-Verlag, New York, 2005.
130. Z. LUO AND J. SHEN. Stability results for impulsive functional differential equations with infinite delays. *Journal of Computational and Applied Mathematics*, **131**(1-2), pp. 55–64, 2001.
131. W. LU AND T. CHEN. Dynamical behaviors of cohen-grossberg neural networks with discontinuous activation functions. *Neural Networks*, **18**(3), pp. 231–242, 2005.
132. W. LU AND T. CHEN. Dynamical behaviors of delayed neural network systems with discontinuous activation functions. *Neural Computation*, **18**(3), pp. 683–708, 2006.
133. W. LU AND T. CHEN. Almost periodic dynamics of a class of delayed neural networks with discontinuous activations. *Neural computation*, **20**(4), pp. 1065–1090, 2008.
134. N. A. LYNCH. *Distributed Algorithms*. The Morgan Kaufmann Series in Data Management Systems. Morgan Kaufmann, San Francisco, CA, 1996.
135. J.L. MANCILLA-AGUILAR AND R.A. GARCIA. On converse Lyapunov theorems for ISS and iISS switched nonlinear systems. *Systems & Control Letters*, **42**(1), pp. 47–53, 2001.
136. J.L. MANCILLA-AGUILAR AND R.A. GARCIA. An extension of LaSalle’s invariance principle for switched systems. *Systems & Control Letters*, **55**(5), pp. 376–384, 2006.
137. X. MAO AND C. YUAN. *Stochastic Differential Equations with Markovian Switching*. Imperial College Press, London, 2006.
138. X. MAO. Razumikhin-type theorems on exponential stability of stochastic functional differential equations. *Stochastic Processes and Their Applications*, **65**(2), pp. 233–250, 1996.
139. X. MAO. Stochastic versions of the LaSalle theorem. *Journal of Differential Equations*, **153**(1), pp. 175–195, 1999.
140. X. MAO. *Stochastic Differential Equations and Applications*. Horwood Publishing Limited, Chichester, second edition, 2008.
141. C.M. MARCUS AND R.M. WESTERVELT. Stability of analog neural networks with delay. *Physical Review A*, **39**(1), pp. 347–359, 1989.
142. A.S. MATVEEV AND A.V. SAVKIN. *Qualitative Theory of Hybrid Dynamical Systems*. Birkhauser, Boston, MA, 2000.
143. S.E.A. MOHAMMED. *Stochastic Functional Differential Equations*, vol. 99 of *Research Notes in Mathematics*. Pitman, Boston, MA, 1984.

144. L. MOREAU. Stability of multiagent systems with time-dependent communication links. *IEEE Transactions on Automatic Control*, **50**(2), pp. 169–182, 2005.
145. P. NAGHSHTABRIZI. *Delay Impulsive Systems: A Framework For Modeling Networked Control Systems*. PhD thesis, University of California, Santa Barbara, 2007.
146. C.E. NEUMAN AND V. COSTANZA. Deterministic impulse control in native forest ecosystems management. *Journal of Optimization Theory and Applications*, **66**(2), pp. 173–196, 1990.
147. R. OLFATI-SABER, J.A. FAX, AND R.M. MURRAY. Consensus and cooperation in networked multi-agent systems. *Proceedings of the IEEE*, **95**(1), pp. 215–233, 2007.
148. R. OLFATI-SABER AND R.M. MURRAY. Consensus problems in networks of agents with switching topology and time-delays. *IEEE Transactions on Automatic Control*, **49**(9), pp. 1520–1533, 2004.
149. D. PAPINI AND V. TADDEI. Global exponential stability of the periodic solution of a delayed neural network with discontinuous activations. *Physics Letters A*, **343**(1-3), pp. 117–128, 2005.
150. P. PELETIES AND R. DECARLO. Asymptotic stability of m-switched systems using Lyapunov-like functions. In *Proceedings of the 1991 American Control Conference*, pp. 1679–1684, JUN. 1991.
151. P. PEPE AND Z.P. JIANG. A Lyapunov-Krasovskii methodology for ISS and iISS of time-delay systems. *Systems & Control Letters*, **55**(12), pp. 1006–1014, 2006.
152. S. PETTERSSON AND B. LENNARTSON. Stability and robustness for hybrid systems. In *Proceedings of the 35th IEEE Conference on Decision and Control*, pp. 1202–1207, 1996.
153. W. REN, R.W. BEARD, AND D.B. KINGSTON. Multi-agent kalman consensus with relative uncertainty. In *Proceedings of the 2005 American Control Conference*, pp. 1865–1870, 2005.
154. W. REN AND R.W. BEARD. Consensus seeking in multiagent systems under dynamically changing interaction topologies. *IEEE Transactions on Automatic Control*, **50**(5), pp. 655–661, 2005.
155. J.P. RICHARD. Time-delay systems: an overview of some recent advances and open problems. *Automatica*, **39**(10), pp. 1667–1694, 2003.
156. AM SAMOILENKO AND NA PERESTYUK. *Impulsive Differential Equations*. World Scientific Publishing Co., Inc., River Edge, NJ, 1995.

157. R.G. SANFELICE, R. GOEBEL, AND A.R. TEEL. Invariance principles for hybrid systems with connections to detectability and asymptotic stability. *IEEE Transactions on Automatic Control*, **52**(12), pp. 2282–2297, DEC. 2007.
158. A.J. SCHAFT AND J.M. SCHUMACHER. *An Introduction to Hybrid Dynamical Systems*. Springer-Verlag, London, 2000.
159. S. SCHWINNING, O.E. SALA, M.E. LOIK, AND J.R. EHLERINGER. Thresholds, memory, and seasonality: understanding pulse dynamics in arid/semi-arid ecosystems. *Oecologia*, **141**(2), pp. 191–193, 2004.
160. J. SHEN, Z. LUO, AND X. LIU. Impulsive stabilization of functional differential equations via Liapunov functionals. *Journal of Mathematical Analysis and Applications*, **240**(1), pp. 1–15, 1999.
161. R. SHORTEN, F. WIRTH, O. MASON, K. WULFF, AND C. KING. Stability criteria for switched and hybrid systems. *SIAM Review*, **49**(4), pp. 545, 2007.
162. E.D. SONTAG. Smooth stabilization implies coprime factorization. *IEEE Transactions on Automatic Control*, **34**(4), pp. 435–443, 1989.
163. E.D. SONTAG. Comments on integral variants of ISS. *Systems & Control Letters*, **34**(1-2), pp. 93–100, 1998.
164. E. D. SONTAG. Input to state stability: basic concepts and results. In *Nonlinear and optimal control theory*, VOL. 1932 of *Lecture Notes in Mathematics*, pp. 163–220. Springer, Berlin, 2008.
165. T.M. STAUNER. *Systematic Development of Hybrid Systems*. PhD thesis, Technische Universität München, Universitätsbibliothek, 2001.
166. P. STECHLINSKI. A study of infectious disease models with switching. Master's thesis, University of Waterloo, 2009.
167. S.H. STROGATZ. Exploring complex networks. *Nature*, **410**(6825), pp. 268–276, 2001.
168. Z. SUN AND S.S. GE. *Switched Linear Systems: Control and Design*. Springer Verlag, 2005.
169. A.R. TEEL. Connections between Razumikhin-type theorems and the ISS nonlinear small gain theorem. *IEEE Transactions on Automatic Control*, **43**(7), pp. 960–964, JUL. 1998.
170. J. TSINIAS. Stochastic input-to-state stability and applications to global feedback stabilization. *International Journal of Control*, **71**(5), pp. 907–930, 1998.

171. J. TSINIAS. The concept of “exponential input to state stability” for stochastic systems and applications to feedback stabilization. *Systems & Control Letters*, **36**(3), pp. 221–229, 1999.
172. J. TSITSIKLIS AND M. ATHANS. Convergence and asymptotic agreement in distributed decision problems. *IEEE Transactions on Automatic Control*, **29**(1), pp. 42–50, 2002.
173. J. TSITSIKLIS, D. BERTSEKAS, AND M. ATHANS. Distributed asynchronous deterministic and stochastic gradient optimization algorithms. *IEEE Transactions on Automatic Control*, **31**(9), pp. 803–812, 2002.
174. L. VU, D. CHATTERJEE, AND D. LIBERZON. Input-to-state stability of switched systems and switching adaptive control. *Automatica*, **43**(4), pp. 639–646, 2007.
175. G.C. WALSH, O. BELDIMAN, AND L.G. BUSHNELL. Asymptotic behavior of nonlinear networked control systems. *IEEE Transactions on Automatic Control*, **46**(7), pp. 1093–1097, JUL. 2001.
176. J. WANG, D. CHENG, AND X. HU. An extension of LaSalle’s invariance principle for a class of switched linear systems. *Systems & Control Letters*, **58**(10-11), pp. 754–758, 2009.
177. J. WANG, L. HUANG, AND Z. GUO. Dynamical behavior of delayed hopfield neural networks with discontinuous activations. *Applied Mathematical Modelling*, **33**(4), pp. 1793–1802, 2009.
178. Q. WANG AND X. LIU. Impulsive stabilization of delay differential systems via the Lyapunov-Razumikhin method. *Applied Mathematics Letters*, **20**(8), pp. 839–845, 2007.
179. Y. WANG, G. XIE, AND L. WANG. Controllability of switched time-delay systems under constrained switching. *Journal of Mathematical Analysis and Applications*, **286**(2), pp. 397–421, 2003.
180. Y. WANG, Y. ZUO, L. HUANG, AND C. LI. Global robust stability of delayed neural networks with discontinuous activation functions. *IET Control Theory & Applications*, **2**(7), pp. 543–553, 2008.
181. M.A. WICKS AND R.A. DECARLO. Solution of coupled Lyapunov equations for the stabilization of multimodal linear systems. In *Proceedings of the 1997 American Control Conference*, pp. 1709–1713, 1997.

182. M.A. WICKS, P. PELETIES, AND R.A. DECARLO. Construction of piecewise Lyapunov functions for stabilizing switched systems. In *Proceedings of the 33rd IEEE Conference on Decision and Control*, pp. 3492–3497, 1994.
183. M. WICKS, P. PELETIES, AND R. DECARLO. Switched controller synthesis for the quadratic stabilisation of a pair of unstable linear systems. *European Journal of Control*, **4**(2), pp. 140–147, 1998.
184. L. XIAO, S. BOYD, AND S.J. KIM. Distributed average consensus with least-mean-square deviation. *Journal of Parallel and Distributed Computing*, **67**(1), pp. 33–46, 2007.
185. G. XIE AND L. WANG. Necessary and sufficient conditions for controllability and observability of switched impulsive control systems. *IEEE Transactions on Automatic Control*, **49**(6), pp. 960 – 966, JUN. 2004.
186. G. XIE AND L. WANG. Stabilization of switched linear systems with time-delay in detection of switching signal. *Journal of Mathematical Analysis and Applications*, **305**(1), pp. 277–290, 2005.
187. W.C. XIE. *Dynamic Stability of Structures*. Cambridge University Press, 2006.
188. H. XU, X. LIU, AND K.L. TEO. Delay independent stability criteria of impulsive switched systems with time-invariant delays. *Mathematical and Computer Modelling*, **47**(3-4), pp. 372–379, 2008.
189. H. XU, X. LIU, AND K.L. TEO. A LMI approach to stability analysis and synthesis of impulsive switched systems with time delays. *Nonlinear Analysis: Hybrid Systems*, **2**(1), pp. 38–50, 2008.
190. H. XU AND K.L. TEO. Robust stabilization of uncertain impulsive switched systems with delayed control. *Computers & Mathematics with Applications*, **56**(1), pp. 63–70, 2008.
191. T. YANG AND L.O. CHUA. Impulsive stabilization for control and synchronization of chaotic systems: theory and application to secure communication. *IEEE Transactions on Circuits and Systems I: Fundamental Theory and Applications*, **44**(10), pp. 976 –988, 1997.
192. Z. YANG AND D. XU. Impulsive stabilization of large-scale dynamical systems. *Dynamic Systems and Applications*, **15**(3/4), pp. 317–331, 2006.

193. J. YAN AND J. SHEN. Impulsive stabilization of functional differential equations by Lyapunov-Razumikhin functions. *Nonlinear Analysis: Theory, Methods & Applications*, **37**(2), pp. 245–255, 1999.
194. P. YAN AND H. ÖZBAY. Stability analysis of switched time delay systems. *SIAM Journal on Control and Optimization*, **47**, pp. 936, 2008.
195. N. YEGANEFAR, P. PEPE, AND M. DAMBRINE. Input-to-state stability of time-delay systems: A link with exponential stability. *IEEE Transactions on Automatic Control*, **53**(6), pp. 1526–1531, 2008.
196. H. YE, A.N. MICHEL, AND L. HOU. Stability theory for hybrid dynamical systems. *IEEE Transactions on Automatic Control*, **43**(4), pp. 461–474, 1998.
197. T. YOSHIZAWA. *Stability Theory by Liapunov's Second Method*. Mathematical Society of Japan, 1966.
198. K. YOSIDA. *Functional Analysis*. Classics in Mathematics. Springer-Verlag, Berlin, 1995. Reprint of the sixth (1980) edition.
199. G. ZHAI, B. HU, K. YASUDA, AND A.N. MICHEL. Stability analysis of switched systems with stable and unstable subsystems: an average dwell time approach. *International Journal of Systems Science*, **32**(8), pp. 1055–1061, 2001.
200. Y. ZHANG, X. LIU, AND X. SHEN. Stability of switched systems with time delay. *Nonlinear Analysis: Hybrid Systems*, **1**(1), pp. 44–58, 2007.
201. H. ZHAO. Global asymptotic stability of hopfield neural network involving distributed delays. *Neural networks*, **17**(1), pp. 47–53, 2004.
202. Y. ZUO, Y. WANG, L. HUANG, Z. WANG, X. LIU, AND X. WU. Robust stability criterion for delayed neural networks with discontinuous activation functions. *Neural Processing Letters*, **29**(1), pp. 29–44, 2009.

Author's Publications

1. JUN LIU, XINZHI LIU, WEI-CHAU XIE, AND HONGTAO ZHANG. Stochastic consensus seeking with communication delays. *Automatica*, under review.
2. JUN LIU, XINZHI LIU, AND WEI-CHAU XIE. Global convergence of neural networks with mixed time-varying delays and discontinuous neuron activations. *Information Sciences*, under review (revised).
3. XINZHI LIU, XUEMIN SHEN, HONGTAO ZHANG, AND JUN LIU. A family of new chaotic and hyperchaotic attractors from delay differential equations. *Chaos, Solitons & Fractals*, under review.
4. JUN LIU, XINZHI LIU, AND WEI-CHAU XIE. Input-to-state stability of impulsive and switching hybrid systems with time-delay. *Automatica*, to appear.
5. JUN LIU, XINZHI LIU, AND WEI-CHAU XIE. Stability and stabilization of impulsive and switched hybrid stochastic delay systems. *The Journal of Nonlinear Science and Its Applications*, to appear.
6. JUN LIU, XINZHI LIU, AND WEI-CHAU XIE. Generalized invariance principles for switched delay systems. *IMA Journal of Mathematical Control and Information*, to appear.
7. JUN LIU, XINZHI LIU, AND WEI-CHAU XIE. Impulsive stabilization of stochastic functional differential equations. *Applied Mathematics Letters*, **24**, pp. 264–269, 2011.
8. JUN LIU, XINZHI LIU, AND WEI-CHAU XIE. Existence and uniqueness results for impulsive hybrid stochastic delay systems. *Communications on Applied Nonlinear Analysis*, **17**(3), pp. 37–54, 2010.
9. JUN LIU, XINZHI LIU, AND WEI-CHAU XIE. Extending LaSalle's invariance principle to impulsive switched systems with an application to hybrid epidemic dynamics. *Control and Decision Conference (CCDC), 2010 Chinese*, pp. 136–141, 2010. (Won the **Zhang Si-Ying Outstanding Youth Paper Award**.)
10. JUN LIU, XINZHI LIU, AND WEI-CHAU XIE. On the (h_0, h) -stabilization of switched nonlinear systems via state-dependent switching rule. *Applied Mathematics and Computation*, **217**(5), pp. 2067–2083, 2010.

11. JUN LIU, XINZHI LIU, AND WEI-CHAU XIE. Exponential stability of switched stochastic delay systems with non-linear uncertainties. *International Journal of Systems Science*, **40**(6), pp. 637–648, 2009.
12. JUN LIU, XINZHI LIU, AND WEI-CHAU XIE. Invariance principles for impulsive switched systems. *Dynamics of Continuous, Discrete and Impulsive Systems. Series B. Applications and Algorithms*, **16**(5), pp. 631–654, 2009.
13. JUN LIU, XINZHI LIU, AND WEI-CHAU XIE. Robust stabilization of stochastic switched delay systems via state-dependent switching rule. *Dynamic Systems and Applications*, **18**(2), pp. 213–239, 2009.
14. JUN LIU, XINZHI LIU, AND WEI-CHAU XIE. Robust exponential stability of uncertain switched stochastic systems with time-delay. *Dynamics of Continuous, Discrete and Impulsive Systems. Series A. Mathematical Analysis*, **16**(S1), pp. 174–181, 2009.
15. JUN LIU, XINZHI LIU, AND WEI-CHAU XIE. Uniform stability of switched nonlinear systems. *Nonlinear Analysis: Hybrid Systems*, **3**(4), pp. 441–454, 2009.
16. JUN LIU, XINZHI LIU, AND WEI-CHAU XIE. Delay-dependent robust control for uncertain switched systems with time-delay. *Nonlinear Analysis: Hybrid Systems*, **2**(1), pp. 81–95, 2008.